

Algebra & Number Theory

Volume 10

2016

No. 7



Algebra & Number Theory

msp.org/ant

EDITORS

MANAGING EDITOR

Bjorn Poonen
Massachusetts Institute of Technology
Cambridge, USA

EDITORIAL BOARD CHAIR

David Eisenbud
University of California
Berkeley, USA

BOARD OF EDITORS

Dave Benson	University of Aberdeen, Scotland	Susan Montgomery	University of Southern California, USA
Richard E. Borcherds	University of California, Berkeley, USA	Shigefumi Mori	RIMS, Kyoto University, Japan
John H. Coates	University of Cambridge, UK	Raman Parimala	Emory University, USA
J-L. Colliot-Thélène	CNRS, Université Paris-Sud, France	Jonathan Pila	University of Oxford, UK
Brian D. Conrad	Stanford University, USA	Anand Pillay	University of Notre Dame, USA
Hélène Esnault	Freie Universität Berlin, Germany	Victor Reiner	University of Minnesota, USA
Hubert Flenner	Ruhr-Universität, Germany	Peter Sarnak	Princeton University, USA
Sergey Fomin	University of Michigan, USA	Joseph H. Silverman	Brown University, USA
Edward Frenkel	University of California, Berkeley, USA	Michael Singer	North Carolina State University, USA
Andrew Granville	Université de Montréal, Canada	Vasudevan Srinivas	Tata Inst. of Fund. Research, India
Joseph Gubeladze	San Francisco State University, USA	J. Toby Stafford	University of Michigan, USA
Roger Heath-Brown	Oxford University, UK	Ravi Vakil	Stanford University, USA
Craig Huneke	University of Virginia, USA	Michel van den Bergh	Hasselt University, Belgium
Kiran S. Kedlaya	Univ. of California, San Diego, USA	Marie-France Vignéras	Université Paris VII, France
János Kollár	Princeton University, USA	Kei-Ichi Watanabe	Nihon University, Japan
Yuri Manin	Northwestern University, USA	Efim Zelmanov	University of California, San Diego, USA
Philippe Michel	École Polytechnique Fédérale de Lausanne	Shou-Wu Zhang	Princeton University, USA

PRODUCTION

production@msp.org

Silvio Levy, Scientific Editor

See inside back cover or msp.org/ant for submission instructions.

The subscription price for 2016 is US \$290/year for the electronic version, and \$485/year (+\$55, if shipping outside the US) for print and electronic. Subscriptions, requests for back issues and changes of subscribers address should be sent to MSP.

Algebra & Number Theory (ISSN 1944-7833 electronic, 1937-0652 printed) at Mathematical Sciences Publishers, 798 Evans Hall #3840, c/o University of California, Berkeley, CA 94720-3840 is published continuously online. Periodical rate postage paid at Berkeley, CA 94704, and additional mailing offices.

ANT peer review and production are managed by EditFLOW® from MSP.

PUBLISHED BY

 **mathematical sciences publishers**
nonprofit scientific publishing

<http://msp.org/>

© 2016 Mathematical Sciences Publishers

Arithmetic invariant theory and 2-descent for plane quartic curves

Jack A. Thorne
Appendix by Tasho Kaletha

Given a smooth plane quartic curve C over a field k of characteristic 0, with Jacobian variety J , and a marked rational point $P \in C(k)$, we construct a reductive group G and a G -variety X , together with an injection $J(k)/2J(k) \hookrightarrow G(k) \backslash X(k)$. We do this using the Mumford theta group of the divisor 2Θ of J , and a construction of Lurie which passes from Heisenberg groups to Lie algebras.

Introduction	1373
1. Background	1379
2. A group with involution	1384
3. Plane quartic curves	1387
Appendix by Tasho Kaletha: A converse to Lurie's functorial construction of simply laced Lie algebras	1401
Acknowledgements	1411
References	1412

Introduction

Motivation. Let C be a smooth, projective, geometrically connected algebraic curve over a field k of characteristic 0, and let J denote its Jacobian variety. It is of interest to calculate the group $J(k)/2J(k)$. For example, when $k = \mathbb{Q}$, this is often the first step in understanding the structure of the finitely generated abelian group $J(\mathbb{Q})$. Calculating the group $J(k)/2J(k)$ is known as performing a 2-descent.

In order to calculate $J(k)/2J(k)$, it is often very useful to be able to understand this group in terms of explicit objects in representation theory. This is particularly the case if one wishes to understand the behavior of the groups $J(k)/2J(k)$ as the curve C is allowed to vary. A famous example is the description of this group in terms of binary quartic forms, in the case where $C = J$ is an elliptic

This research was partially conducted during the period Thorne served as a Clay Research Fellow. Kaletha was supported in part by NSF grant DMS-1161489.

MSC2010: primary 11D25; secondary 11E72.

Keywords: arithmetic geometry, descent, invariant theory.

curve [Birch and Swinnerton-Dyer 1963]. More recently, Bhargava and Gross [2013] and Wang [2013] have given a similar description in the case where C is an odd hyperelliptic curve, i.e., a hyperelliptic curve with a marked rational Weierstrass point $P \in C(k)$. In this case, the group $J(k)/2J(k)$ is understood in terms of equivalence classes of self-adjoint linear operators with fixed characteristic polynomial.

The aim of this paper is to give an invariant-theoretic description of the group $J(k)/2J(k)$ when C is a nonhyperelliptic genus-3 curve with a marked rational point $P \in C(k)$. Such a curve is canonically embedded as a quartic curve in \mathbb{P}_k^2 , which explains the title of this paper. The set of such pairs (C, P) breaks up into 4 natural families, according to the behavior of the projective tangent line to C at P (these are described below).

Our results can be summarized in broad terms as follows: for each family of curves, we obtain a reductive group G over k , an algebraic variety X on which G acts, and, for each pair $x = (C, P)$ defined over k , a closed G -orbit $X_x \subset X$ and a canonical injection

$$J(k)/2J(k) \hookrightarrow G(k) \backslash X_x(k).$$

If k is separably closed, then the set $G(k) \backslash X_x(k)$ has a single element. In general, the set $X_x(k)$ of k -rational points breaks up into many $G(k)$ -orbits, which become conjugate over the separable closure. The set of $G(k)$ -orbits can be described in terms of Galois cohomology, and this allows us to make a link with the theory of 2-descent.

Two of the spaces X that we construct are in fact linear representations, and our results in these cases (although not our proofs) parallel those in [Bhargava and Gross 2013, §4]. Bhargava and Gross apply the results of [loc. cit.] to understand the average size of the 2-Selmer group of the Jacobian of an odd hyperelliptic curve over \mathbb{Q} . We hope that our results will have similar applications in the future, but we do not pursue the study of Selmer groups in this paper.

The other two spaces we construct are global analogues of Vinberg's θ -groups, which have been previously studied from the point of view of geometric invariant theory by Richardson [1982b]. We wonder if they can have similar applications in arithmetic invariant theory, and if there are similar and simpler spaces which are related, for example, to elliptic curves.

Description of main results. We now describe more precisely what we prove in this paper. Let k be a field of characteristic 0. We are interested in the arithmetic of all pairs (C, P) over k , where C is a smooth nonhyperelliptic curve of genus 3, and $P \in C(k)$ is a marked rational point. We break up such pairs into 4 families, corresponding to the behavior of the projective tangent line $\ell = T_P C$ in the canonical embedding:

Case E_7 : ℓ meets C at exactly 3 points (the generic case).

Case e_7 : ℓ meets C at exactly 2 points, with contact of order 3 at P (ℓ is a flex).

Case E_6 : ℓ meets C at exactly 2 points, with contact of order 2 at P (ℓ is a bitangent line).

Case e_6 : ℓ meets C at exactly 1 point (ℓ is a hyperflex).

The name for each case indicates the semisimple algebraic group or Lie algebra inside which we will construct the variety X described above. The definitions are as follows:

Case E_7 : Let H be a split adjoint simple group of type E_7 , and let $\theta : H \rightarrow H$ be a split stable involution (see [Proposition 1.9](#) below). We define G to be the identity component of the θ -fixed group H^θ , and Y to be the connected component of the identity in the θ -inverted set $H^{\theta(h)=h^{-1}}$. (Equivalently, Y can be realized as the quotient H/G .)

Case e_7 : Let H, θ , and G be as in case E_7 . We define V to be the tangent space to Y at the identity, where Y is as in case E_7 . Then V is a linear representation of G , and can be identified with the -1 -eigenspace of θ in $\mathfrak{h} = \text{Lie } H$.

Case E_6 : Let H be instead a split adjoint simple group of type E_6 , and let $\theta : H \rightarrow H$ be a split stable involution. We define G to be the identity component of the θ -fixed group H^θ , and Y to be the connected component of the identity in the θ -inverted set $H^{\theta(h)=h^{-1}}$.

Case e_6 : Let H, θ , and G be as in case E_6 . We define V to be the tangent space to Y at the identity, where Y is as in case E_6 . Equivalently, $V = \mathfrak{h}^{\theta=-1} \subset \mathfrak{h}$.

In case E_7 or E_6 , we let $X = Y$. In case e_7 or e_6 , we let $X = V$. In each case the open subscheme $X^s \subset X$ of geometric stable orbits (i.e., closed orbits with finite stabilizers) is nonempty, and can be realized as the complement of a discriminant hypersurface. A Chevalley restriction theorem holds, and if k is separably closed then two elements $x, y \in X^s(k)$ are $G(k)$ -conjugate if and only if they have the same image in the categorical quotient $X//G$. (We remark that the quotients $V//G$ are abstractly isomorphic to affine space. This is not so for the quotients $Y//G$, although it would be so if in their definition we replaced the adjoint group H by its simply connected cover.) The spaces V are linear representations of G of the type arising from Vinberg theory, and have been studied in the context of arithmetic invariant theory in, e.g., [[Thorne 2013](#)]. The spaces Y are a “global” analogue of the representations V .

Our first main result is the construction of a point of $G(k) \backslash X^s(k)$ which corresponds to the trivial element of the group $J(k)/2J(k)$:

Theorem 1 (see [Theorem 3.5](#)). (1) *In case E_7 or E_6 , let \mathcal{S} denote the functor $k\text{-alg} \rightarrow \text{Sets}$ which classifies pairs (C, P) , where C is a smooth, nonhyperelliptic curve of genus 3, and P is a point of C as above. Then there is a canonical map*

$$\mathcal{S}(k) \rightarrow G(k) \setminus Y^s(k).$$

If k is separably closed, then this map is bijective.

(2) *In case ϵ_7 or ϵ_6 , let \mathcal{S} denote the functor $k\text{-alg} \rightarrow \text{Sets}$ which classifies tuples (C, P, t) , where C is a smooth nonhyperelliptic curve of genus 3, P is a point of C as above, and t is a nonzero element of the Zariski tangent space of C at P . Then there is a canonical map*

$$\mathcal{S}(k) \rightarrow G(k) \setminus V^s(k).$$

If k is separably closed, this map is bijective.

In any of the above cases, given $x \in \mathcal{S}(k)$ corresponding to a tuple (C, P, \dots) , we write J_x for the Jacobian of C and $X_x \subset X$ for the geometric stable orbit containing the image of x , where again $X = Y$ in case E_7 or E_6 , and $X = V$ in case ϵ_7 or ϵ_6 . As noted above, $G(k)$ acts transitively on $X_x(k)$ if k is separably closed, but in general this is not the case; instead, the orbits comprising $G(k) \setminus X_x(k)$ can be described in terms of Galois cohomology. Our main theorem shows how to construct orbits in $G(k) \setminus X_x(k)$ using rational points of $J_x(k)$:

Theorem 2 (see [Theorem 3.6](#)). *Let notation be as above. Then there is a canonical injection $J_x(k)/2J_x(k) \hookrightarrow G(k) \setminus X_x(k)$. The image of the identity element of $J_x(k)$ is the image of x under the map of [Theorem 1](#).*

We observe that the Jacobian J_x depends only on the curve C , but the set $G(k) \setminus X_x(k)$ depends on the choice of auxiliary data; an analogous situation arises when doing 2-descent on the Jacobian of a hyperelliptic curve which has more than one k -rational Weierstrass point.

Methods. The methods we adopt to prove [Theorems 1](#) and [2](#) seem to be different to preceding work of a similar type. This reflects the fact that we are now in the territory of exceptional groups, whereas, e.g., 2-descent on hyperelliptic curves can be understood using the invariant theory of Vinberg θ -groups which are constructed inside classical groups (in fact, groups of type A_n).

Our starting point is a classical geometric construction. For concreteness, we describe what happens just in the case of type E_6 . Let us therefore take a smooth, nonhyperelliptic curve C over \mathbb{C} of genus 3, and let $P \in C(\mathbb{C})$ be a marked point where the projective tangent line in the canonical embedding is a bitangent line. The double cover $\pi : S \rightarrow \mathbb{P}^2$ branched over C is a del Pezzo surface of degree 2, and the strict transform of ℓ is the union of two -1 -curves; blowing down one of these, we obtain a smooth cubic surface S .

There is a well-known connection between cubic surfaces and the root system of type E_6 : let $\Lambda = K_S^\perp \subset H^2(S, \mathbb{Z})$ denote the orthogonal complement of the canonical class of S . Then Λ is in fact a root lattice of type E_6 . This does not immediately provide a relation with geometric invariant theory because there is no functorial construction of a reductive group from a root lattice.

However, Lurie [2001] has observed that one can construct in a functorial way the group H corresponding to Λ given the additional data of a *double cover* of $V = \Lambda/2\Lambda$, i.e., a group extension

$$1 \rightarrow \{\pm 1\} \rightarrow \tilde{V} \rightarrow V \rightarrow 1 \tag{0-1}$$

satisfying some additional conditions—in particular, that the quadratic form $q : V \rightarrow \mathbb{F}_2$ corresponding to this extension agrees with the one derived from the natural quadratic form on Λ .

It turns out that the realization of the cubic surface X using the plane quartic curve C is exactly the data required for input into Lurie’s construction. Indeed, let J denote the Jacobian of the curve C . Then J has a natural principal polarization Θ , and associated to $\mathcal{L} = 2\Theta$ is the Mumford theta group

$$1 \rightarrow \{\pm 1\} \rightarrow \tilde{H}_{\mathcal{L}} \rightarrow J[2] \rightarrow 1. \tag{0-2}$$

(More precisely, the Mumford theta group is a central extension of $J[2]$ by \mathbb{G}_m . The presence of the odd theta characteristic corresponding to the bitangent ℓ allows us to refine it to an extension by $\{\pm 1\}$.) We show that there is a canonical isomorphism $J[2] \cong \Lambda/2\Lambda$; pushing out the sequence (0-2) by this isomorphism, we obtain a sequence of type (0-1), to which Lurie’s construction applies. We thus obtain from the data (C, ℓ) an algebraic group of type E_6 . (We remark here that the isomorphism $J[2] \cong \Lambda/2\Lambda$ is well-known and classical; see, for example, [Dolgachev and Ortland 1988, Chapter IX, §1]. We thank the anonymous referee for this reference.)

The principle underlying this paper is that the construction outlined above is sufficiently functorial that we can recover the arithmetic situation over any field k of characteristic 0 simply by Galois descent. To construct the orbits whose existence is asserted by Theorem 2, we simply twist the extension (0-2). More precisely, we recall in Section 1C below how a point of $J_x(k)$ gives rise to a twisted form of the Heisenberg group $\tilde{H}_{\mathcal{L}}$. We then construct additional orbits by applying our version of Lurie’s construction to this twisted Heisenberg group.

Other remarks. There are some minor subtleties in our construction that we remark on now. One point is that, in cases ϵ_6, ϵ_7 , we associate orbits not to pairs (C, P) but to triples (C, P, t) , where t is a nonzero Zariski tangent vector at the point P . This reflects the fact that the space X constructed in this case has an extra symmetry: it is

a linear representation of the reductive group G , so we are free to multiply elements by scalars. This scaling corresponds to scaling the tangent vector t . A similar feature appears in [Bhargava and Gross 2013], where it allows one to “clear denominators” when working over \mathbb{Q} , and restrict to integral orbits.

Another point is that, in the geometric construction sketched above, we associate a point to a pair (C, ℓ) , and do not need the point P which gives rise to the bitangent ℓ . Of course, ℓ being fixed, there are exactly two possible choices of point P . It turns out that, in each case, the data of the point P is exactly the data required to rigidify the picture so that we obtain the expected bijection (as in Theorem 1) when k is separably closed. This is an essential feature, since we rely heavily on Galois descent.

Our modified version of Lurie’s construction associates to an appropriate extension \tilde{V} with action by the absolute Galois group of k a triple $(\mathfrak{h}, \mathfrak{t}, \theta)$ consisting of a Lie algebra over k of the correct Dynkin type, a Cartan subalgebra $\mathfrak{t} \subset \mathfrak{h}$, and a stable involution θ of \mathfrak{h} which acts as multiplication by -1 on \mathfrak{t} . For arithmetic applications, we extend this construction in a surprising way: we show that a representation of the group \tilde{V} appearing in the extension (0-1), and on which -1 acts as multiplication by -1 , gives rise to a representation of the θ -fixed Lie algebra \mathfrak{h}^θ .

The features of these constructions suggest that they should have an inverse, i.e., that, given a tuple $(\mathfrak{h}, \mathfrak{t}, \theta)$ consisting of a simple Lie algebra \mathfrak{h} over k , a Cartan subalgebra $\mathfrak{t} \subset \mathfrak{h}$ and an involution θ of \mathfrak{h} which acts as -1 on \mathfrak{t} , one should be able to pass in the opposite direction to obtain a root lattice Λ with Γ_k -action and an extension \tilde{V} of $V = \Lambda/2\Lambda$ of type (0-1). The existence of such an inverse has been shown by Tasho Kaletha, and appears in the Appendix to this paper. He finds the group \tilde{V} inside the simply connected cover of the group $G = (H^\theta)^\circ$, where H is the adjoint simple group over k with Lie algebra \mathfrak{h} . In Section 3B, we apply these results to calculate the number of orbits with given invariants in the case $k = \mathbb{R}$.

Organization of this paper. In Section 1 below, we recall some basic facts about quadratic forms, 2-descent for abelian varieties, and the invariant theory of the G -varieties under consideration here. In Section 2 we describe our modifications to Lurie’s constructions. In Section 3 we apply these constructions to the geometry of plane quartics, in order to arrive at the results described in this introduction. We conclude in Section 3B with an explicit example in the case $k = \mathbb{R}$.

Notation. Throughout this paper, k will denote a field of characteristic 0, and k^s a fixed separable closure of k . We write $\Gamma_k = \text{Gal}(k^s/k)$. If X is a k -vector space or a scheme of finite type over k , then we write X_{k^s} for the object obtained by extending scalars to k^s . If X is a smooth projective variety over k , then we write K_X for its canonical class. If G, H, \dots are connected algebraic groups over k , then we

use gothic letters $\mathfrak{g}, \mathfrak{h}, \dots$ to denote their Lie algebras. If H is an algebraic group over k , then we write $H^1(k, H)$ for the continuous cohomology set $H^1(\Gamma_k, H(k^s))$, where $H(k^s)$ is endowed with the discrete topology. If θ is an involution of H , then we write H^θ for the closed subgroup of H consisting of θ -fixed elements, and \mathfrak{h}^θ for the Lie algebra of H (equivalently, the $+1$ -eigenspace of the differential of θ in \mathfrak{h}). We will make use of the equivalence between commutative finite k -groups and $\mathbb{Z}[\Gamma_k]$ -modules of finite cardinality (given by $H \mapsto H(k^s)$).

By definition, a lattice $(\Lambda, \langle \cdot, \cdot \rangle)$ is a finite free \mathbb{Z} -module Λ together with a symmetric and positive-definite bilinear form $\langle \cdot, \cdot \rangle : \Lambda \times \Lambda \rightarrow \mathbb{Z}$. We define $\Lambda^\vee = \{\lambda \in \Lambda \otimes_{\mathbb{Z}} \mathbb{Q} \mid \langle \lambda, \Lambda \rangle \subset \mathbb{Z}\}$, which is naturally identified with $\text{Hom}(\Lambda, \mathbb{Z})$. We call Λ a (simply laced) root lattice if it satisfies the following additional conditions:

- For each $\lambda \in \Lambda$, $\langle \lambda, \lambda \rangle$ is an even integer.
- The set $\Gamma = \{\lambda \in \Lambda \mid \langle \lambda, \lambda \rangle = 2\}$ generates Λ as an abelian group.

In this case, Γ is a simply laced root system, each $\gamma \in \Gamma$ being associated with the simple reflection $s_\gamma(x) = x - \langle x, \gamma \rangle \gamma$. If Γ is *irreducible*, then it is a root system of type A, D , or E . In any case, we write $W(\Lambda) \subset \text{Aut}(\Lambda)$ for the Weyl group of Γ , a finite group generated by the simple reflections $s_\gamma, \gamma \in \Gamma$.

In several places, we will consider central group extensions of the form

$$1 \rightarrow \{\pm 1\} \rightarrow \tilde{E} \rightarrow E \rightarrow 1.$$

If $\tilde{e} \in \tilde{E}$, then we will write $-\tilde{e}$ for the element $(-1) \cdot \tilde{e}$. We note that this is not necessarily equal to \tilde{e}^{-1} . We write e for the image of \tilde{e} in E .

1. Background

We first recall some background material. For proofs of the results in Sections 1A and 1B, we refer the reader to [Gross and Harris 2004].

1A. Quadratic forms over \mathbb{F}_2 . Let V be a finite-dimensional \mathbb{F}_2 -vector space, and let $\langle \cdot, \cdot \rangle : V \times V \rightarrow \mathbb{F}_2$ be a strictly alternating pairing.

Definition 1.1. A quadratic refinement of V is a function $q : V \rightarrow \mathbb{F}_2$ such that, for all $v, w \in V$, we have $\langle v, w \rangle = q(v + w) + q(v) + q(w)$.

In general, there is no distinguished quadratic refinement of V . However, we have the following result.

Proposition 1.2. *Suppose that the pairing $\langle \cdot, \cdot \rangle$ is nondegenerate.*

- (1) *Fix a decomposition $V = U \oplus U'$, where U, U' are isotropic subspaces of dimension $g \geq 0$. Then the function $q_{U, U'}(v) = \langle v_U, v_{U'} \rangle$ is a quadratic refinement. (Here we write $v_U, v_{U'}$ for the projections of $v \in V$ onto the two isotropic subspaces.)*

- (2) *The set of quadratic refinements of V is a principal homogeneous space for V , addition being defined by the formula $(v + q)(w) = q(w) + \langle v, w \rangle$.*

Definition 1.3. Suppose that the pairing $\langle \cdot, \cdot \rangle$ is nondegenerate, and let q be a quadratic refinement of V . The Arf invariant $a(q) \in \mathbb{F}_2$ of q is defined as follows. Fix a decomposition $V = U \oplus U'$ into isotropic subspaces of dimension $g \geq 0$. Let $\{e_1, \dots, e_g\}$ be a basis of U , and let $\{\epsilon_1, \dots, \epsilon_g\}$ denote the dual basis of U' . Then $a(q) = \sum_{i=1}^g q(e_i)q(\epsilon_i)$.

Lemma 1.4. *Suppose that the pairing $\langle \cdot, \cdot \rangle$ is nondegenerate, and let $\dim V = 2g$.*

- (1) *The Arf invariant $a(q)$ is well-defined.*
- (2) *Let $\mathrm{Sp}(V)$ denote the group of automorphisms of the pair $(V, \langle \cdot, \cdot \rangle)$. Then $\mathrm{Sp}(V)$ has precisely 2 orbits on the set of quadratic refinements of V , which are distinguished by their Arf invariants. The set of refinements with $a(q) = 0$ has cardinality $2^{g-1}(2^g + 1)$ and the set of refinements with $a(q) = 1$ has cardinality $2^{g-1}(2^g - 1)$.*
- (3) *If q is a quadratic refinement and $v \in V$, then $a(q + v) = a(q) + q(v)$.*

1B. Theta characteristics. Let k be a field of characteristic 0, and let C be a smooth, projective, geometrically irreducible curve over k , of genus $g \geq 2$. We write K_C for the canonical bundle of C , and $J = \mathrm{Pic}^0(C)$ for the Jacobian of C . We write $V = J[2]$, a finite k -group. We view V as an \mathbb{F}_2 -vector space of dimension $2g$ with continuous Γ_k -action. The Weil pairing defines a nondegenerate, strictly alternating bilinear form $\langle \cdot, \cdot \rangle : V \times V \rightarrow \mathbb{F}_2$ which is Γ_k -invariant.

Definition 1.5. (1) A theta characteristic is a line bundle \mathcal{L} on C such that $\mathcal{L}^{\otimes 2} \cong K_C$.

(2) Let \mathcal{L} be a theta characteristic. We say that \mathcal{L} is odd (resp. even) if $h^0(\mathcal{L})$ is odd (resp. even).

Here and below we write $h^0(\mathcal{L}) = \dim_k H^0(C, \mathcal{L})$ for any line bundle \mathcal{L} on the curve C .

Lemma 1.6. (1) *As a principal homogeneous space for V , the k -variety of isomorphism classes of theta characteristics is canonically identified with the k -scheme of quadratic refinements of the Weil pairing: if \mathcal{L} is a theta characteristic, we associate to it the quadratic refinement $q : V \rightarrow \mathbb{F}_2$ defined by the formula $q(v) = h^0(\mathcal{L} \otimes_{\mathcal{O}_C} v) + h^0(v) \pmod{2}$.*

- (2) *With notation as above, the Arf invariant of q is $a(q) = h^0(\mathcal{L}) \pmod{2}$.*

Henceforth, we identify the set of theta characteristics of the curve C with the set of quadratic refinements $\kappa : V \rightarrow \mathbb{F}_2$.

1C. Heisenberg groups and descent. We continue with the notation of Section 1B. Let J^{g-1} denote the J -torsor of degree- $(g - 1)$ line bundles on C ; it contains the theta divisor W_{g-1} . Given a theta characteristic κ defined over k , we have the translation map $t_\kappa : J \rightarrow J^{g-1}$, $\mathcal{L} \mapsto \mathcal{L} \otimes \kappa$, and we define $\Theta_\kappa = t_\kappa^* W_{g-1}$. It is a symmetric divisor, and all symmetric theta divisors arise in this fashion. (This is classical; see [Birkenhake and Lange 2004, Chapter 11].) Similarly, if $A \in J(k)$ then there is a translation map $t_A : J \rightarrow J$, $\mathcal{L} \mapsto \mathcal{L} \otimes A$.

The isomorphism class of the line bundle $\mathcal{L}_\kappa = \mathcal{O}_J(2\Theta_\kappa)$ is independent of the choice of κ , but there is no canonical choice of isomorphism as κ varies. In particular, even if κ is defined only over k^s , the field of definition of this bundle is equal to k . We choose a bundle \mathcal{L} in this isomorphism class defined over k . We introduce the Heisenberg group $\tilde{H}_\mathcal{L}$ of pairs (ω, φ) , where $\omega \in J[2]$ and $\varphi : \mathcal{L} \rightarrow t_\omega^* \mathcal{L}$ is an isomorphism. It is an extension

$$0 \rightarrow \mathbb{G}_m \rightarrow \tilde{H}_\mathcal{L} \rightarrow J[2] \rightarrow 0.$$

Lemma 1.7. (1) *Let $\omega, \eta \in J[2]$, and let $\tilde{\omega}, \tilde{\eta}$ denote lifts of these elements to $\tilde{H}_\mathcal{L}$. Then $\tilde{\omega}\tilde{\eta}\tilde{\omega}^{-1}\tilde{\eta}^{-1} = (-1)^{(\omega, \eta)}$.*

(2) *Let $\text{Aut}(\tilde{H}_\mathcal{L}; J[2])$ denote the group of automorphisms of $\tilde{H}_\mathcal{L}$ fixing \mathbb{G}_m point-wise and acting as the identity on $J[2]$. Then the map*

$$\eta \mapsto ((\omega, \varphi) \mapsto (\omega, (-1)^{(\eta, \omega)} \varphi))$$

defines an isomorphism $J[2] \cong \text{Aut}(\tilde{H}_\mathcal{L}; J[2])$.

Proof. The first part can be taken as the definition of the Weil pairing. The second part follows from [Birkenhake and Lange 2004, Lemma 6.6.6]. □

If κ is a theta characteristic defined over k , then we can define a character $\chi_\kappa : \tilde{H}_\mathcal{L} \rightarrow \mathbb{G}_m$ by the formula $\chi_\kappa(\tilde{\omega}) = \tilde{\omega}^2(-1)^{q_\kappa(\omega)}$. (This makes sense since the square of any element of $\tilde{H}_\mathcal{L}$ lies in \mathbb{G}_m .) We then have an exact sequence

$$1 \rightarrow \{\pm 1\} \rightarrow \ker \chi_\kappa \rightarrow J[2] \rightarrow 1. \tag{1-1}$$

This construction will play an important role later on; compare the required data at the beginning of Section 2 below.

Associated to J is the Kummer exact sequence

$$0 \rightarrow J[2] \rightarrow J \rightarrow J \rightarrow 0,$$

and the associated short exact sequence in Galois cohomology

$$0 \rightarrow J(k)/2J(k) \xrightarrow{\delta} H^1(k, J[2]) \rightarrow H^1(k, J)[2] \rightarrow 0.$$

The map δ can be written down explicitly as follows: given $A \in J(k)$, choose $B \in J(k^s)$ such that $[2](B) = A$. Then the cohomology class $\delta(A)$ is represented by the cocycle $\sigma \mapsto {}^\sigma B - B$.

We now give another interpretation of this homomorphism in terms of the group $\tilde{H}_{\mathcal{L}}$. The field of definition of the line bundle $t_B^* \mathcal{L}$ is equal to k ; we let \mathcal{L}_B denote a choice of descent to k , unique up to k -isomorphism. This allows us to define the Heisenberg group $\tilde{H}_{\mathcal{L}_B}$ of pairs (ω, φ) , where $\omega \in J[2]$ and φ is an isomorphism $\mathcal{L}_B \rightarrow t_{\omega}^* \mathcal{L}_B$. We also fix a choice of isomorphism $f : \mathcal{L}_B \rightarrow t_B^* \mathcal{L}$ over k^s .

The choice of f defines an isomorphism $F : (\tilde{H}_{\mathcal{L}})_{k^s} \cong (\tilde{H}_{\mathcal{L}_B})_{k^s}$, given by the formula

$$F : (\omega, \varphi) \mapsto (\omega, t_{\omega}^* f^{-1} \circ t_B^* \varphi \circ f). \tag{1-2}$$

We define a cocycle valued in $\text{Aut}(\tilde{H}_{\mathcal{L}}; J[2])$ by the formula $\sigma \mapsto F^{-1} \circ {}^\sigma F$.

Lemma 1.8. *This cocycle is equal to the cocycle $\sigma \mapsto {}^\sigma B - B$ under the identification of Lemma 1.7.*

In particular, this cocycle depends only on B , and not on any other choice.

Proof. The proof is by an explicit calculation, $F^{-1} \circ {}^\sigma F$ being given by

$$(\omega, \varphi) \mapsto (\omega, t_{\omega-B}^* f \circ t_{-B}^* [t_{\omega}^* \sigma f^{-1} \circ t_{\sigma B}^* \varphi \circ \sigma f] \circ t_{-B}^* f^{-1}).$$

We must show that this expression is equal to $(\omega, (-1)^{\langle \omega, \sigma B - B \rangle} \varphi)$. However, writing $\eta = {}^\sigma B - B$ and $\psi = t_{-\sigma B}^* (f \circ \sigma f^{-1})$, we have $(\eta, \psi) \in \tilde{H}_{\mathcal{L}}$ and, by Lemma 1.7,

$$\begin{aligned} (\omega, (-1)^{\langle \omega, \sigma B - B \rangle} \varphi) &= (\eta, \psi)(\omega, \varphi)(\eta, \psi)^{-1}(\omega, \varphi)^{-1}(\omega, \varphi) \\ &= (\eta, \psi)(\omega, \varphi)(\eta, \psi)^{-1} \\ &= (\omega, t_{\omega+\eta}^* \psi \circ t_{\eta}^* \varphi \circ t_{\eta}^* \psi^{-1}). \end{aligned}$$

Expanding this expression now shows it to be equal to $F^{-1} \circ {}^\sigma F$. □

1D. Invariant theory of reductive groups with involution. Let k be a field of characteristic 0, and let H be a split adjoint simple group over k of type A, D , or E .

Proposition 1.9. *There exists a unique $H(k)$ -conjugacy class of involutions θ of H satisfying the following two conditions:*

- (1) $\text{tr}(d\theta : \mathfrak{h} \rightarrow \mathfrak{h}) = -\text{rank } H$.
- (2) *The group $(H^\theta)^\circ$ is split.*

Proof. The result [Thorne 2013, Corollary 2.15] states that there is a unique $H(k)$ -orbit of involutions $\theta : H \rightarrow H$ such that $\text{tr } d\theta = -\text{rank } H$ and $\mathfrak{h}^{d\theta=-1}$ contains a regular nilpotent element. The discussion there also shows by construction that, for each θ in this class, the group $(H^\theta)^\circ$ is split. We must show that if $\theta : H \rightarrow H$ is

an involution such that $\text{tr } d\theta = -\text{rank } H$ and $(H^\theta)^\circ$ is split, then $\mathfrak{h}^{d\theta=-1}$ contains a regular nilpotent. Let $\mathfrak{t}_0 \subset \mathfrak{h}^{d\theta=1}$ be a split Cartan subalgebra, and let $\mathfrak{t} \subset \mathfrak{h}$ be a split Cartan subalgebra containing \mathfrak{t}_0 .

By [Thorne 2013, Lemmas 2.6 and 2.14], we can find a normal \mathfrak{sl}_2 -triple (E, X, F) in $\mathfrak{h} \otimes_k k^s$, i.e., a tuple of elements $E, X, F \in \mathfrak{h} \otimes_k k^s$ satisfying the relations

$$\begin{aligned} [E, F] &= X, & \theta(X) &= X, \\ [X, E] &= 2E, & \theta(E) &= -E, \\ [X, F] &= -2F, & \theta(F) &= -F, \end{aligned}$$

with E regular nilpotent and $X \in \mathfrak{t}_0 \otimes_k k^s$. Since X is part of an \mathfrak{sl}_2 -triple, it follows that $\alpha(X) \in \mathbb{Z}$ for every root of \mathfrak{t} in \mathfrak{h} , hence $X \in \mathfrak{t}$, hence $X \in \mathfrak{t}_0$. By [de Graaf 2011, Proposition 7], we can find elements $E' \in \mathfrak{h}^{d\theta=-1}$ and $F' \in \mathfrak{h}^{d\theta=-1} \otimes_k k^s$ such that (E', X, F') is a normal \mathfrak{sl}_2 -triple. In particular, E' is a regular nilpotent. This completes the proof. \square

Henceforth, we fix a choice of θ satisfying the conclusion of Proposition 1.9 and write $G = (H^\theta)^\circ$. Then G is a split semisimple group. (For a proof that G is semisimple, see Section A2 of the Appendix to this paper.) We will study the invariant theory of two different actions of G . We first consider $V = \mathfrak{h}^{d\theta=-1}$. Then V is a linear representation of the group G .

Theorem 1.10. (1) *V satisfies the Chevalley restriction theorem: if $\mathfrak{t} \subset V$ is a Cartan subalgebra, then the map $N_G(\mathfrak{t}) \rightarrow W_{\mathfrak{t}} = N_H(\mathfrak{t})/Z_H(\mathfrak{t})$ is surjective, and the inclusion $\mathfrak{t} \subset V$ induces an isomorphism*

$$\mathfrak{t} // W_{\mathfrak{t}} \cong V // G.$$

In particular, the quotient $V // G$ is isomorphic to affine space.

- (2) *Suppose that $k = k^s$, and let $x, y \in V$ be regular semisimple elements. Then x is $G(k)$ -conjugate to y if and only if x, y have the same image in $V // G$.*
- (3) *There exists a discriminant polynomial $\Delta \in k[V]$ such that, for all $x \in V$, x is regular semisimple if and only if $\Delta(x) \neq 0$, if and only if the G -orbit of x is closed in V and $\text{Stab}_G(x)$ is finite.*

Proof. This follows from results of Vinberg, which are summarized in [Panyushev 2005] or (in our case of interest) [Thorne 2013, §2]. \square

We now consider the variety $Y \subset H$, the locally closed image of the morphism $H \rightarrow H, h \mapsto h^{-1}\theta(h)$. It is a connected component of the subvariety $\{h \in H \mid \theta(h) = h^{-1}\}$, and is in particular closed in H . Note that Y has a marked point (namely the identity element of H), and the tangent space to Y at this marked

point is canonically isomorphic, as a G -representation, to the representation V defined above.

Theorem 1.11. (1) Y satisfies the Chevalley restriction theorem: if $T \subset Y$ is a maximal torus, then $N_G(T) \rightarrow W_T = N_H(T)/Z_H(T)$ is surjective, and the inclusion $T \subset Y$ induces an isomorphism

$$T // W_T \cong Y // G.$$

- (2) Suppose that $k = k^s$, and let $x, y \in Y$ be regular semisimple elements. Then x is $G(k)$ -conjugate to y if and only if x, y have the same image in $Y // G$.
- (3) There exists a discriminant polynomial $\Delta \in k[Y]$ such that, for all $x \in Y$, x is regular semisimple if and only if $\Delta(x) \neq 0$, if and only if the G -orbit of x is closed in Y and $\text{Stab}_G(x)$ is finite.

Proof. See [Richardson 1982b, §0]. □

2. A group with involution

Let k be a field of characteristic 0. Suppose that we are given the following data:

- An irreducible simply laced root lattice $(\Lambda, \langle \cdot, \cdot \rangle)$ together with a continuous homomorphism $\Gamma_k \rightarrow W(\Lambda) \subset \text{Aut}(\Lambda)$.
- A central extension \tilde{V} of $V = \Lambda/2\Lambda$

$$0 \rightarrow \{\pm 1\} \rightarrow \tilde{V} \rightarrow V \rightarrow 0$$

together with a homomorphism $\Gamma_k \rightarrow \text{Aut}(\tilde{V})$. We suppose that Γ_k leaves invariant the subgroup $\{\pm 1\}$, and that the induced homomorphism $\Gamma_k \rightarrow \text{Aut}(V)$ agrees with the homomorphism $\Gamma_k \rightarrow \text{Aut}(\Lambda) \rightarrow \text{Aut}(\Lambda/2\Lambda) = \text{Aut}(V)$. We also suppose that, for $\tilde{v} \in \tilde{V}$, we have the relation $\tilde{v}^2 = (-1)^{\frac{1}{2}\langle v, v \rangle}$.

In terms of this data we will define, following [Lurie 2001]:

- (1) A simple Lie algebra \mathfrak{h} over k of type equal to the Dynkin type of Λ .
- (2) A maximal torus T of H , the adjoint group over k with Lie algebra \mathfrak{h} , together with an isomorphism $T[2](k^s) \cong V^\vee$ of $\mathbb{Z}[\Gamma_k]$ -modules.
- (3) An involution $\theta : H \rightarrow H$ leaving T stable, and satisfying $\theta(t) = t^{-1}$ for all $t \in T(k)$.

Suppose, given further the data of a finite-dimensional k -vector space W and a homomorphism $\rho : \tilde{V} \rightarrow \text{GL}(W_{k^s})$ such that $\rho(-1) = -\text{id}_W$ and for all $\sigma \in \Gamma_k$ and $\tilde{v} \in \tilde{V}$, we have $\rho(\sigma\tilde{v}) = \sigma\rho(\tilde{v})$. Then we will further define:

- (4) A Lie algebra homomorphism $R : \mathfrak{h}^\theta \rightarrow \mathfrak{gl}(W)$.

(Using the equivalence between $\mathbb{Z}[\Gamma_k]$ -modules of finite cardinality and commutative finite k -groups, ρ corresponds to a homomorphism $\tilde{V} \rightarrow \text{GL}(W)$ of k -groups.)

Let $\tilde{\Lambda}$ equal $\Lambda \times_V \tilde{V}$, a central extension of Λ by $\{\pm 1\}$. Let $\Gamma \subset \Lambda$ be the set of roots, and $\tilde{\Gamma} \subset \tilde{\Lambda}$ its inverse image. Following [Lurie 2001], we define L' to be the free abelian group on symbols $X_{\tilde{\gamma}}$ for $\tilde{\gamma} \in \tilde{\Gamma}$, modulo the relation $X_{\tilde{\gamma}} = -X_{-\tilde{\gamma}}$. (Thus $\{\tilde{\gamma}, -\tilde{\gamma}\}$ is the inverse image in $\tilde{\Gamma}$ of $\gamma \in \Gamma$.) We set $L = \Lambda^\vee \oplus L'$, and define a bracket $[\cdot, \cdot] : L \times L \rightarrow L$ by the formulae:

- $[\lambda, \lambda'] = 0$ for all $\lambda, \lambda' \in \Lambda^\vee$.
- $[\lambda, X_{\tilde{\gamma}}] = -[X_{\tilde{\gamma}}, \lambda] = \langle \lambda, \gamma \rangle X_{\tilde{\gamma}}$ for $\lambda \in \Lambda^\vee$.
- $[X_{\tilde{\gamma}}, X_{\tilde{\gamma}'}] = X_{\tilde{\gamma}\tilde{\gamma}'}$ if $\gamma + \gamma' \in \Gamma$.
- $[X_{\tilde{\gamma}}, X_{\tilde{\gamma}'}] = \epsilon_{\tilde{\gamma}\tilde{\gamma}'} \gamma$ if $\gamma + \gamma' = 0$. (By definition, $\epsilon_{\tilde{\gamma}\tilde{\gamma}'} = \tilde{\gamma}\tilde{\gamma}' \in \{\pm 1\} \subset \mathbb{Z}$.)
- $[X_{\tilde{\gamma}}, X_{\tilde{\gamma}'}] = 0$ otherwise.

Theorem 2.1. (1) L is a Lie algebra over \mathbb{Z} . There is a natural action of Γ_k on L , respecting the Lie bracket $[\cdot, \cdot]$.

(2) Let $\mathfrak{h} = (L \otimes_k k^s)^{\Gamma_k}$. Then \mathfrak{h} is a simple Lie algebra over k of Dynkin type equal to the type of the root lattice Λ .

Proof. (1) That L is a Lie algebra over \mathbb{Z} of the required type follows from [Lurie 2001, §3.1]. The Galois group Γ_k acts on Λ and on $\tilde{\Gamma}$ by the given data. We make it act on $L = \Lambda \oplus L'$ by its standard action on Λ and on L' by permuting basis vectors $X_{\tilde{\gamma}}$, $\tilde{\gamma} \in \tilde{\Gamma}$. It is immediate from the definition that this respects the bracket.

(2) By Galois descent, the natural map $\mathfrak{h}_{k^s} \rightarrow L \otimes_k k^s$ is an isomorphism. The result follows immediately from this. □

Let H denote the simple adjoint group over k with Lie algebra \mathfrak{h} . Let $\mathfrak{t} = (\Lambda^\vee \otimes_k k^s)^{\Gamma_k} \subset \mathfrak{h}$; it is the Lie algebra of a maximal torus T of H , whose module of characters $X^*(T_{k^s})$ is identified with the $\mathbb{Z}[\Gamma_k]$ -module Λ . In particular, there is an isomorphism of $\mathbb{Z}[\Gamma_k]$ -modules $T[2](k^s) \cong \Lambda^\vee / 2\Lambda^\vee \cong V^\vee$.

We now define the involution θ . Given $\tilde{\gamma} \in \tilde{\Gamma}$, we define $Y_{\tilde{\gamma}} = X_{\tilde{\gamma}^{-1}}$. By definition, then, $[X_{\tilde{\gamma}}, Y_{\tilde{\gamma}}] = \gamma \in \Lambda$. It is easy to check that $Y_{-\tilde{\gamma}} = -Y_{\tilde{\gamma}}$. We define an involution $\sigma : L \rightarrow L$ by taking σ to be multiplication by -1 on Λ and by taking $\sigma(X_{\tilde{\gamma}}) = -Y_{\tilde{\gamma}}$.

Proposition 2.2. (1) σ is a well-defined Lie algebra involution, and respects the action of the group Γ_k .

(2) Let θ denote the involution of \mathfrak{h} induced by σ by functoriality. Then $\text{tr } \theta = -\text{rank } \mathfrak{h}$.

Proof. (1) We must check that σ preserves the relations defining $[\cdot, \cdot]$. Let us show that $\sigma[X_{\tilde{\gamma}}, X_{\tilde{\gamma}'}] = \sigma X_{\tilde{\gamma}\tilde{\gamma}'} = -Y_{\tilde{\gamma}\tilde{\gamma}'}$ is equal to $[\sigma X_{\tilde{\gamma}}, \sigma X_{\tilde{\gamma}'}] = [X_{\tilde{\gamma}^{-1}}, X_{\tilde{\gamma}'^{-1}}] =$

$X_{\tilde{\gamma}^{-1}\tilde{\gamma}'^{-1}}$, when $\gamma + \gamma' \in \Gamma$. Equivalently, we must show that $\tilde{\gamma}\tilde{\gamma}' = -\tilde{\gamma}'\tilde{\gamma}$. By the definition of $\tilde{\Lambda}$, it is equivalent to show that $\langle \gamma, \gamma' \rangle$ is odd. Since we work in a simply laced root system, this is implied by the condition that $\gamma + \gamma'$ is a root.

(2) This follows because θ acts as -1 on \mathfrak{t} . □

We define $G = (H^\theta)^\circ$. We define N_V to be the image of the natural homomorphism $V \rightarrow V^\vee$; it is a $\mathbb{Z}[\Gamma_k]$ -module, and the induced symplectic form on N_V is nondegenerate and Γ_k -equivariant. The isomorphism $T[2] \cong V^\vee$ restricts to an isomorphism $(T[2] \cap G) \cong N_V$ (cf. [Thorne 2013, Corollary 2.8]).

It remains to define, given a finite-dimensional k -vector space W and a Galois-equivariant homomorphism $\rho : \tilde{V} \rightarrow \text{GL}(W_{k^s})$ such that $\rho(-1) = -\text{id}_W$, a Lie algebra homomorphism $R : \mathfrak{g} \rightarrow \mathfrak{gl}(W)$. Let us first assume that $k = k^s$. Then the Lie algebra \mathfrak{g} is spanned by the elements $X_{\tilde{\gamma}} + X_{-\tilde{\gamma}^{-1}} = Z_{\tilde{\gamma}}$, say. Let $\pi : \tilde{\Gamma} \rightarrow \tilde{V}$ denote the natural map. We define a morphism $R : \mathfrak{g} \rightarrow \mathfrak{gl}(W)$ of k -vector spaces by the formula

$$R(Z_{\tilde{\gamma}}) = \frac{1}{2}\rho(\pi(\tilde{\gamma})).$$

This is well-defined since $Z_{\tilde{\gamma}} = -Z_{-\tilde{\gamma}} = -Z_{\tilde{\gamma}^{-1}}$, and $\pi(\tilde{\gamma}) = (-1)^{\frac{1}{2}\langle \gamma, \gamma \rangle} \pi(\tilde{\gamma})^{-1} = -\pi(\tilde{\gamma})^{-1}$. In the case $k \neq k^s$, this defines a homomorphism $\mathfrak{g}_{k^s} \rightarrow \mathfrak{gl}(W_{k^s})$ which commutes with the action of Γ_k , and we write $R : \mathfrak{g} \rightarrow \mathfrak{gl}(W)$ for the homomorphism obtained by Galois descent.

Proposition 2.3. *$R : \mathfrak{g} \rightarrow \mathfrak{gl}(W)$ is a Lie algebra homomorphism.*

Proof. We can again assume that $k = k^s$. We must show that, given $\tilde{\gamma}, \tilde{\gamma}' \in \tilde{\Gamma}$, we have

$$R([Z_{\tilde{\gamma}}, Z_{\tilde{\gamma}'}]) = [R(Z_{\tilde{\gamma}}), R(Z_{\tilde{\gamma}'})].$$

We now break up into cases according to the value of $\langle \gamma, \gamma' \rangle$.

- (1) If $\langle \gamma, \gamma' \rangle = \pm 2$, then $\gamma' = \pm\gamma$, hence $\tilde{\gamma}' = \pm\tilde{\gamma}^{\pm 1}$, and both sides of the above equation are zero.
- (2) If $\langle \gamma, \gamma' \rangle = \pm 1$, then $\gamma \mp \gamma'$ is a root. Let us assume for simplicity that $\langle \gamma, \gamma' \rangle = -1$, so that $\gamma + \gamma'$ is a root, and $[Z_{\tilde{\gamma}}, Z_{\tilde{\gamma}'}] = Z_{\tilde{\gamma}\tilde{\gamma}'}$. We must show that

$$\frac{1}{2}\rho(\pi(\tilde{\gamma}\tilde{\gamma}')) = \frac{1}{4}\rho(\pi(\tilde{\gamma})) \cdot \rho(\pi(\tilde{\gamma}')) - \frac{1}{4}\rho(\pi(\tilde{\gamma}')) \cdot \rho(\pi(\tilde{\gamma})).$$

This follows from the fact that $\tilde{\gamma}'\tilde{\gamma} = (-1)^{\langle \gamma, \gamma' \rangle} \tilde{\gamma}\tilde{\gamma}' = -\tilde{\gamma}\tilde{\gamma}'$ and $\rho(-1) = -\text{id}_W$.

- (3) If $\langle \gamma, \gamma' \rangle = 0$ then neither of $\gamma \pm \gamma'$ is a root, and the left-hand side of the above equation is zero. On the other hand, $\pi(\tilde{\gamma})$ and $\pi(\tilde{\gamma}')$ commute, so the right-hand side is also zero.

This concludes the proof. □

The above constructions are evidently functorial in \tilde{V} , in the following sense: given \tilde{V} , \tilde{V}_B satisfying the conditions at the beginning of this section, and a Γ_k -equivariant isomorphism $f : \tilde{V} \rightarrow \tilde{V}_B$, we obtain an isomorphism of associated simple adjoint groups $F : H \cong H_B$, intertwining θ, θ_B , and restricting to an isomorphism $T \rightarrow T_B$ which induces the identity on Λ . In this connection, we have the following lemma.

- Lemma 2.4.** (1) *Let us write $\text{Aut}(\tilde{V}; V)$ for the group of automorphisms of \tilde{V} leaving the central subgroup $\{\pm 1\}$ invariant and inducing the identity on V . Then there is a canonical isomorphism $V^\vee \cong \text{Aut}(\tilde{V}; V)$, given by $f \mapsto (\tilde{v} \mapsto (-1)^{f(\tilde{v})} \cdot \tilde{v})$.*
- (2) *Let $f \in V^\vee$, and let F denote the induced automorphism of the triple (H, θ, T) . Let s denote the image of f under the canonical isomorphism $V^\vee \cong T[2](k^s)$. Then $F = \text{Ad}(s)$.*

Proof. (1) Immediate.

(2) The automorphism f induces the automorphism $\tilde{\gamma} \mapsto (-1)^{f(\tilde{\gamma})} \tilde{\gamma}$ of $\tilde{\Gamma}$. We must therefore show that $(-1)^{f(\tilde{\gamma})} = \langle \gamma, s \rangle$. However, this follows from the definition of the element s . □

3. Plane quartic curves

Let k be a field of characteristic 0 and C a smooth (geometrically connected, projective) nonhyperelliptic curve of genus 3 over k . The canonical embedding then gives C as a plane quartic curve in \mathbb{P}_k^2 ; let us write $\pi : S \rightarrow \mathbb{P}_k^2$ for the double cover of \mathbb{P}_k^2 branched over S . Then S is a del Pezzo surface of degree 2, i.e., a smooth surface with $-K_S$ ample and $K_S^2 = 2$. (We note that if $k \neq k^s$, then S depends, up to isomorphism, on a choice of defining equation of C ; a particular choice will be specified below. The set of isomorphism classes is a torsor for $k^\times / (k^\times)^2$.)

Proposition 3.1. (1) *The group $\text{Pic}(S_{k^s})$ is free of rank 8 over \mathbb{Z} . Its natural intersection pairing is unimodular.*

(2) *The sublattice $\Lambda = K_S^\perp \subset \text{Pic}(S_{k^s})$ is a root lattice of type E_7 .*

(3) *Suppose that ℓ is a bitangent line of C in its canonical embedding. Then $\pi^{-1}(\ell_{k^s}) = e \cup f$ is a union of two smooth curves of genus 0. Define $\Lambda_\ell = \langle e, f \rangle^\perp \subset \Lambda$. Then Λ_ℓ is a root lattice of type E_6 .*

(4) *There are natural isomorphisms $\Lambda^\vee \cong \text{Pic}(S_{k^s}) / \mathbb{Z}K_S$ and $\Lambda_\ell^\vee \cong \text{Pic}(S_{k^s}) / \langle e, f \rangle$.*

(5) *Each of $\text{Pic}(S_{k^s})$, Λ , and Λ_ℓ (when it is defined) has a natural structure of $\mathbb{Z}[\Gamma_k]$ -module, which respects the intersection pairings.*

Proof. This is all classical; see [Griffiths and Harris 1994, pp. 545–549] and [Dolgachev 2012, Chapter 8]. It is useful to note that S_{k^s} can be realized as the blowup of $\mathbb{P}_{k^s}^2$ at 7 points in general position. \square

We define N_C to be the image of the natural map $\Lambda/2\Lambda \rightarrow \Lambda^\vee/2\Lambda^\vee$. Viewing $C \subset S$ as the ramification locus of π , we see that there is a natural Γ_k -equivariant map $\text{Pic}(S_{k^s}) \rightarrow \text{Pic}(C_{k^s})$ given by restriction of line bundles.

Proposition 3.2. *There is a commutative diagram of finite k -groups*

$$\begin{array}{ccc} \Lambda^\vee/2\Lambda^\vee & \xrightarrow{\cong} & (\text{Pic}(C)/\mathbb{Z}K_C)[2] \\ \uparrow & & \uparrow \\ N_C & \xrightarrow{\cong} & \text{Pic}^0(C)[2] \end{array}$$

Proof. We first define the maps. The top map is induced by the composite

$$\Lambda^\vee \cong \text{Pic}(S)/\mathbb{Z}K_S \rightarrow \text{Pic}(C)/\mathbb{Z}K_C,$$

which takes image in $(\text{Pic}(C)/\mathbb{Z}K_C)[2] \subset \text{Pic}(C)/\mathbb{Z}K_C$. It is well-defined since $K_S|_C = -K_C$, and if D is any divisor class on S then $2D|_C \sim (D + \iota^*D)|_C$ is a multiple of K_C (where $\iota : S \rightarrow S$ is the involution which swaps sheets). The left and right maps are the natural inclusions. To see that the bottom map is derived from the top one, it is enough to note that if D is a divisor class in Λ , then $\deg D|_C = \langle K_S, D \rangle = 0$, so $D|_C \in \text{Pic}^0(C)[2]$.

We now show that the top and bottom maps are isomorphisms. We can assume that $k = k^s$. The groups in the top row have the same cardinality, 2^7 . If ℓ is a bitangent line of C corresponding to an odd theta characteristic $\kappa \in (\text{Pic}(C)/\mathbb{Z}K_C)[2]$, and $\pi^{-1}(\ell) = e \cup f$, then the image of $e \in \Lambda^\vee$ in $(\text{Pic}(C)/\mathbb{Z}K_C)[2]$ equals κ . The group $(\text{Pic}(C)/\mathbb{Z}K_C)[2]$ is generated by the odd theta characteristics. This shows that the top arrow is surjective, hence an isomorphism. The groups in the bottom row have the same cardinality, 2^6 , and the bottom arrow is injective. It is therefore also an isomorphism, and this completes the proof. \square

As pointed out in the introduction, Proposition 3.2 is essentially classical.

Proposition 3.3. (1) *Under the isomorphism $N_C \cong \text{Pic}^0(C)[2]$ of Proposition 3.2, the natural symplectic form on N_C is identified with the Weil pairing on $\text{Pic}^0(C)[2]$.*

(2) *Let ℓ be a k -rational bitangent line of C , and let κ denote the corresponding k -rational theta characteristic. Let $q_\ell : N_C \rightarrow \mathbb{F}_2$ denote the quadratic form corresponding to the isomorphism $\Lambda_\ell/2\Lambda_\ell \cong N_C$, and let $q_\kappa : \text{Pic}^0(C)[2] \rightarrow \mathbb{F}_2$ be the quadratic form induced by κ . Then, under the isomorphism $N_C \cong \text{Pic}^0(C)[2]$ of Proposition 3.2, q_ℓ and q_κ are identified.*

Proof. Since q_ℓ and q_κ are quadratic refinements of the symplectic forms, it suffices to prove the second part. These quadratic forms have Arf invariant 1, and therefore have each exactly 28 zeroes. It therefore suffices to show that q_ℓ and q_κ have at least 28 zeroes in common. To do this, we can assume that $k = k^s$. If κ' is any odd theta characteristic of C , then $\kappa - \kappa' \in \text{Pic}^0(C)[2]$ is a zero of q_κ , and there are exactly 28 such elements. (Use the formula $a(q + v) = a(q) + q(v)$ of [Lemma 1.4](#).) We must therefore show that if $v \in \Lambda_\ell$ has image $\kappa - \kappa'$, then $\langle v, v \rangle$ is divisible by 4. This is an easy calculation in $\text{Pic}(S_{k^s})$. \square

We now fix a rational point $P \in C(k)$. We define elements of certain tori and their Lie algebras, following [[Looijenga 1993](#), §1]. We break into 4 cases, according to the geometry of the point P . Let ℓ denote the tangent line to C at P in \mathbb{P}_k^2 , and $K = \pi^{-1}(\ell)$ its inverse image, an anticanonical curve in S .

Case E7: ℓ not a flex. In the most general case, the tangent line at P to C in its plane embedding meets C at 3 distinct points and therefore has contact of order 2 at P . We define a point of the torus $T = \text{Hom}(\Lambda, \mathbb{G}_m)$, up to inversion. Indeed, in this case K is an irreducible rational curve with a unique nodal singularity at P . There is a unique choice of S for which the tangent directions of K at P are defined over k ; we make this choice. Restriction of line bundles induces a homomorphism $\text{Pic}(S) \rightarrow \text{Pic}(K)$. An element of $\text{Pic}(S)$ is orthogonal to K_S (under the intersection pairing) if and only if its restriction to K has degree 0, so we obtain an induced homomorphism $\Lambda \rightarrow \text{Pic}^0(K)$. Choosing a group isomorphism $\text{Pic}^0(K) \cong \mathbb{G}_m$, we now obtain a point $\kappa_C \in T(k)$, well-defined up to inversion.

Case e7: ℓ a flex, not a hyperflex. We now suppose that the tangent line to C at P has contact of order exactly 3, and fix in addition a nonzero tangent vector t in the Zariski tangent space of C at P . We define a point κ_C of the Lie algebra \mathfrak{t} of the torus $T = \text{Hom}(\Lambda, \mathbb{G}_m)$, well-defined up to multiplication by -1 . The curve K is irreducible and rational with a unique cuspidal singularity, at P . Restriction induces a morphism $\Lambda \rightarrow \text{Pic}^0(K)$. To write down κ_C , it therefore suffices to give a normalization of the isomorphism $\text{Pic}^0(K) \cong \mathbb{G}_a$, at least up to sign.

To do this we find it convenient to introduce explicit coordinates. Using Riemann–Roch, it is easy to show that there are unique functions $x, y \in k(C)^\times$ satisfying:

- $x \in H^0(C, \mathcal{O}_C(2P + Q))$ and $y \in H^0(C, \mathcal{O}_C(3P - Q))$.
- Let $z \in \mathcal{O}_{C,P}$ be a coordinate such that $dz(t) = 1$. Then $x = z^{-2} + \dots$ and $y = z^{-3} + \dots$ locally at P .
- x and y satisfy the equation

$$y^3 = x^3y + p_{10}x^2 + x(p_2y^2 + p_8y + p_{14}) + p_6y^2 + p_{12}y + p_{18}$$

for some $p_2, \dots, p_{18} \in k$.

Then we can choose homogeneous coordinates X, Y, Z on \mathbb{P}_k^2 such that C is given by the equation

$$Y^3Z = X^3Y + p_{10}X^2Z^2 + X(p_2Y^2Z + p_8YZ^2 + p_{14}Z^3) + p_6Y^2Z^2 + p_{12}YZ^3 + p_{18}Z^4,$$

and this equation is uniquely determined by the triple (C, P, t) . We use it to define the surface S . Then a chart in S is the affine surface

$$w^2 = z_0 - (x_0^3 + p_{10}x_0^2z_0^2 + \dots + p_{18}z_0^4),$$

where $x_0 = X/Y$, $z_0 = Z/Y$, and the curve K is given locally by the equation $z_0 = 0$. Let $f: \tilde{K} \rightarrow K$ be the normalization. A coordinate in \tilde{K} at the point above P is given by w/x_0 . We use the isomorphism $\mathbb{G}_a \cong \text{Pic}^0(K)$, $t \mapsto \delta(1 + tw/x_0)$, where δ is the connecting homomorphism of the exact sequence of sheaves on K

$$0 \rightarrow \mathcal{O}_K^\times \rightarrow f_*\mathcal{O}_{\tilde{K}}^\times \rightarrow f_*\mathcal{O}_{\tilde{K}}^\times/\mathcal{O}_K^\times \rightarrow 0.$$

Case E_6 : ℓ a bitangent, not a hyperflex. We now suppose that ℓ meets C at two distinct points, say P, Q , and that it has contact of order 2 at each point. Then the root subsystem $\Lambda_\ell \subset \Lambda$ is defined, and we will define a point of the torus $T = \text{Hom}(\Lambda_\ell, \mathbb{G}_m)$. The curve $K_{k^s} = e_{k^s} \cup f_{k^s}$ is a union of two smooth conics, which meet transversely at two distinct points. We choose S so that these conics are defined over k . We thus obtain a homomorphism $\Lambda_\ell \rightarrow \text{Pic}^0(K)^-$, where $(?)^-$ denotes the -1 -eigenspace of the involution induced by switching sheets. The group $\text{Pic}^0(K)^-$ is canonically isomorphic to \mathbb{G}_m , the isomorphism being specified as in [Looijenga 1993, §1.12]: if $s \in \mathbb{G}_m$ tends to 0, then e is contracted to P and f is contracted to Q . We define $\kappa_C \in T(k)$ to be the point obtained via this isomorphism. If the roles of e and f are reversed, then κ_C is replaced by κ_C^{-1} .

Case ϵ_6 : ℓ a hyperflex. We now suppose that ℓ has contact of order 4 with C at P , and fix in addition a nonzero tangent vector t in the Zariski tangent space of C at P . Then the root system $\Lambda_\ell \subset \Lambda$ is defined, and we will define a point κ_C of the Lie algebra \mathfrak{t} of the torus $T = \text{Hom}(\Lambda_\ell, \mathbb{G}_m)$. Restriction once more induces a map $\Lambda_\ell \rightarrow \text{Pic}^0(K)^-$, and we obtain a point $\kappa_C \in \mathfrak{t}$ by specifying an isomorphism $\text{Pic}^0(K)^- \cong \mathbb{G}_a$. To do this, we again introduce explicit coordinates. There are unique functions $x, y \in k(C)^\times$ satisfying:

- $x \in H^0(C, \mathcal{O}_C(3P))$ and $y \in H^0(C, \mathcal{O}_C(4P))$.
- Let $z \in \mathcal{O}_{C,P}$ be a coordinate such that $dz(t) = 1$. Then $x = z^{-3} + \dots$ and $y = z^{-4} + \dots$ locally at P .
- x and y satisfy the equation

$$y^3 = x^4 + y(p_2x^2 + p_5x + p_8) + p_6x^2 + p_9x + p_{12}$$

for some $p_2, \dots, p_{12} \in k$.

Then we can choose homogeneous coordinates X, Y, Z on \mathbb{P}_k^2 such that C is given by the equation

$$Y^3Z = X^4 + Y(p_2X^2Z + p_5XZ^2 + p_8Z^3) + p_6X^2Z^2 + p_9XZ^3 + p_{12}Z^4,$$

and this equation is uniquely determined by the triple (C, P, t) . We use it to define the surface S . A chart in S is the affine surface

$$w^2 = z_0 - (x_0^4 + \dots + p_{12}z_0^4),$$

where $x_0 = X/Y$ and $z_0 = Z/Y$. The curve $K = e \cup f$ is a union of 2 smooth conics which are tangent at the point P , and is given in the above chart by the equation $z_0 = 0$. A coordinate at P in both e and f is given by x_0 . We use the isomorphism $\mathbb{G}_a \cong \text{Pic}^0(K)^-$, $t \mapsto \delta(1 + tx, 1)$, where δ is the connecting homomorphism in the exact sequence of sheaves on K

$$0 \rightarrow \mathcal{O}_K^\times \rightarrow \mathcal{O}_e^\times \oplus \mathcal{O}_f^\times \rightarrow (\mathcal{O}_e^\times \oplus \mathcal{O}_f^\times)/\mathcal{O}_K^\times \rightarrow 0.$$

If the roles of e and f are reversed, then κ_C is replaced by $-\kappa_C$.

In each case, we write $S : k\text{-alg} \rightarrow \text{Sets}$ for the functor of data (C, P, \dots) considered above. This means:

- In case E_7 , S is the functor of pairs (C, P) , where C is a nonhyperelliptic curve of genus 3 and P is a point of C which is not a flex or a bitangent in the canonical embedding. More precisely, for each $A \in k\text{-alg}$, $S(A)$ is the set of isomorphism classes of pairs (π, P) consisting of a proper flat morphism $\pi : C \rightarrow \text{Spec } A$ and a section $P : \text{Spec } A \rightarrow C$ of π such that for each geometric point \bar{s} of $\text{Spec } A$, the pair $(C_{\bar{s}}, P_{\bar{s}})$ is of this type.
- In case ϵ_7 , S is the functor of triples (C, P, t) , where C is a nonhyperelliptic curve of genus 3, P is a point of C which is a flex (but not a hyperflex) in the canonical embedding, and t is a nonzero element of the Zariski tangent space of C at P .
- In case E_6 , S is the functor of pairs (C, P) , where C is a nonhyperelliptic curve of genus 3 and P is a point such that $T_P C$ is a bitangent in the canonical embedding of C .
- In case ϵ_6 , S is the functor of triples (C, P, t) , where C is a nonhyperelliptic curve of genus 3, P is a point which is a hyperflex in the canonical embedding, and t is a nonzero element of the Zariski tangent space of C at P .

We can now state the following reformulation of some results of Looijenga:

Theorem 3.4. *Suppose that $k = k^s$.*

- In case E_7 , let Λ_0 be a root lattice of the corresponding type, and let $T_0 = \text{Hom}(\Lambda_0, \mathbb{G}_m)$. Then the Weyl group $W = W(\Lambda_0)$ acts on T_0 , and the assignment $(C, P) \rightarrow \kappa_C$ induces a bijection $\mathcal{S}(k) \rightarrow (T_0^{\text{rss}} // W)(k)$.
- In case E_6 , let Λ_0 be a root lattice of the corresponding type, and let $T_0 = \text{Hom}(\Lambda_0, \mathbb{G}_m)$. Fix a nontrivial class $e_0 \in \Lambda_0^\vee / \Lambda_0$. Then the Weyl group $W = W(\Lambda_0)$ acts on T_0 , and the assignment $(C, P) \rightarrow \kappa_C$ induces a bijection $\mathcal{S}(k) \rightarrow (T_0^{\text{rss}} // W)(k)$.
- In case e_7 , let Λ_0 be a root lattice of the corresponding type, and let $\mathfrak{t}_0 = \text{Hom}(\Lambda_0, \mathbb{G}_a)$. Then the Weyl group $W = W(\Lambda_0)$ acts on \mathfrak{t}_0 , and the assignment $(C, P, t) \rightarrow \kappa_C$ induces a bijection $\mathcal{S}(k) \rightarrow (\mathfrak{t}_0^{\text{rss}} // W)(k)$.
- In case e_6 , let Λ_0 be a root lattice of the corresponding type, and let $\mathfrak{t}_0 = \text{Hom}(\Lambda_0, \mathbb{G}_a)$. Fix a nontrivial class $e_0 \in \Lambda_0^\vee / \Lambda_0$. Then the Weyl group $W = W(\Lambda_0)$ acts on \mathfrak{t}_0 , and the assignment $(C, P, t) \rightarrow \kappa_C$ induces a bijection $\mathcal{S}(k) \rightarrow (\mathfrak{t}_0^{\text{rss}} // W)(k)$.

The subscript “rss” indicates the open subset of regular semisimple elements, i.e., the complement of all root hyperplanes.

Proof. We first explain what happens in the case of type E_7 . For any field k (not necessarily separably closed), and any pair $(C, P) \in \mathcal{S}(k)$, we have constructed a point κ_C of the torus $T = \text{Hom}(\Lambda, \mathbb{G}_m)$, where Λ is the root lattice with $\mathbb{Z}[\Gamma_k]$ -action constructed above using the curve C .

When $k = k^s$, this action is trivial, and we can choose an isomorphism $\Lambda \cong \Lambda_0$ of root lattices, which is well-defined up to the action of the group $\text{Aut}(\Lambda_0)$. The Dynkin diagram of type E_7 has no extra symmetries, so in fact $\text{Aut}(\Lambda_0) = W$ (see [Bourbaki 2002, Chapter VI, §1, No. 5, Proposition 16]). We thus obtain an isomorphism $T \cong T_0$, well-defined up to the action of W , and a point $\kappa_C \in (T_0 // W)(k) = T_0(k) / W$. Note that κ_C is well-defined only up to inversion, but W contains the element -1 . The result [Looijenga 1993, Proposition 1.8] now states that the point κ_C is regular semisimple, and that the map $\mathcal{S}(k) \rightarrow (T_0^{\text{rss}} // W)(k)$ is a bijection. (In fact, the result is stated when $k = \mathbb{C}$, but the proof is algebrogeometric in nature and goes through without change when k is any separably closed field of characteristic 0.) Indeed, the construction given there is exactly the one we have explicated above.

We now explain what happens in the case of type E_6 . Our construction gives a point $\kappa_C = \kappa(C, P, e)$ of the torus $T = \text{Hom}(\Lambda_\ell, \mathbb{G}_m)$, where e is a choice of irreducible component of the strict transform of the bitangent line ℓ at P inside S ; we have $\kappa(C, P, f) = \kappa(C, P, e)^{-1}$. The automorphism group $\text{Aut}(\Lambda_0)$ is now strictly larger than W , because the Dynkin diagram of type E_6 has extra symmetries, the quotient $\text{Aut}(\Lambda_0) / W$ being generated by the automorphism -1 . In fact, these ambiguities cancel out.

Indeed, the quotient $\Lambda_\ell^\vee/\Lambda_\ell$ is cyclic of order 3, and the quotient $\text{Aut}(\Lambda_0)/W$ acts faithfully on it. We can mark the nontrivial elements of $\Lambda_\ell^\vee/\Lambda_\ell$ by e and f as follows: the class corresponding to e is the one containing the classes of the 27 lines on S which intersect e (but not f), and the class corresponding to f is the one containing the classes of the 27 lines which intersect f (but not e). Let $\lambda_e : \Lambda_\ell \rightarrow \Lambda_0$ be an isomorphism which sends the class in $\Lambda_\ell^\vee/\Lambda_\ell$ corresponding to e to e_0 . Then λ_e is determined up to the action of $W(\Lambda_0)$. The point $\lambda_{e\kappa}(C, P, e) \in (T_0//W)(k)$ is therefore well-defined, and we have $\lambda_{f\kappa}(C, P, f) = (\lambda_{e\kappa}(C, P, e)^{-1})^{-1} = \lambda_{e\kappa}(C, P, e) \bmod W_0$. This gives a map $\mathcal{S}(k) \rightarrow (T_0//W)(k)$ which is independent of any choices, and which is shown to be a bijection into $(T_0^{\text{rss}}//W)(k)$ by [Looijenga 1993, Proposition 1.13].

The Lie algebra cases are very similar, making reference to [Looijenga 1993, Propositions 1.11 and 1.15]. □

3A. Construction of orbits. We now come to the most important part of this paper. In each of the cases E_7, ϵ_7, E_6 and ϵ_6 described above, we give a semisimple group G over k , together with a G -variety X , and write down orbits in $G(k) \setminus X(k)$ corresponding to elements of the groups $J(k)/2J(k)$. We must first fix “reference data”. This means:

- In cases E_7 and ϵ_7 , we fix a choice of pair (H, θ) , where H is a split adjoint simple group over k of type E_7 , and θ is an involution satisfying the conditions of Proposition 1.9. We define $G = (H^\theta)^\circ$, and fix an inner class of isomorphisms $\mathfrak{g} \cong \mathfrak{sl}_8$; equivalently, we distinguish one of the two 8-dimensional representations of \mathfrak{g} as the “standard representation”. The group H has no outer automorphisms, but the group H^θ has two connected components, and the nonidentity component acts on the identity component G by outer automorphisms, exchanging the two choices of standard representation. Indeed, the component group can be calculated using [Reeder 2010, Proposition 2.1] and the Kac coordinates of the inner automorphism θ , which appear in the tables in [Reeder et al. 2012]. The proof of [Reeder 2010, Proposition 2.1] shows that we can find a representative of the nontrivial component which normalizes a maximal torus of G but which does not act on this torus in the same way as any Weyl element of G ; the induced automorphism of G must therefore be outer.

- In cases E_6 and ϵ_6 , we fix a choice of pair (H, θ) , where H is a split adjoint simple group over k of type E_6 , and θ is an involution satisfying the conditions of Proposition 1.9. We define $G = (H^\theta)^\circ = H^\theta$, and distinguish one of the two 27-dimensional representations of \mathfrak{h} as the “standard representation”. The connectedness of H^θ can be shown as above using [Reeder 2010; Reeder et al. 2012].

We recall that in Section 1D we have defined two G -varieties Y and V in terms of the pair (H, θ) . We use these to define the G -variety X as follows:

- In cases E_7 and E_6 , we define $X = Y \subset H$.
- In cases e_7 and e_6 , we define $X = V \subset \mathfrak{h}$.

In each case there is a G -invariant open subscheme $X^s \subset X$ of regular semisimple (equivalently, stable) orbits. We can now state our first main theorem:

Theorem 3.5. *In each case, the assignment $(C, P, \dots) \mapsto \kappa_C$ determines a map*

$$\mathcal{S}(k) \rightarrow G(k) \setminus X^s(k). \tag{3-1}$$

If $k = k^s$, then this map is bijective.

We observe that the theorem has already been proved in the case $k = k^s$. Indeed, in this case, the set $G(k) \setminus X^s(k)$ can be understood, via the Chevalley isomorphisms of Section 1D, in terms of Weyl group orbits in a maximal torus or Cartan subalgebra. Via this isomorphism, the theorem becomes Theorem 3.4. Our problem, then, is to lift this construction so that it works over any field. This also explains the need for the “reference data” described at the beginning of Section 3A: it will provide the correct rigidification, in analogy with what happens in the proof of Theorem 3.4.

We remark that in cases e_7 and e_6 , the functor \mathcal{S} is representable (as the triples (C, P, t) have no automorphisms). This implies that, for any field k , the map $\mathcal{S}(k) \rightarrow G(k) \setminus V^s(k)$ is injective, and the composite $\mathcal{S}(k) \rightarrow G(k) \setminus V^s(k) \rightarrow (V^s // G)(k)$ is bijective.

Proof. Let us first treat the E_7 case. Let $(C, P) \in \mathcal{S}(k)$, and let $V = \Lambda/2\Lambda$. The point κ_C defined above lies in $T(k)$, where $T = \text{Hom}(\Lambda, \mathbb{G}_m)$, and is well-defined up to inversion. We are going to define an extension \tilde{V} of V , with Γ_k -action, and then apply the constructions of Section 2 to build a group around the torus T . Let $\tilde{H}_{\mathcal{L}}$ be the Heisenberg group defined in Section 1C; it fits into an exact sequence

$$1 \rightarrow \mathbb{G}_m \rightarrow \tilde{H}_{\mathcal{L}} \rightarrow \text{Pic}^0(C)[2] \rightarrow 1.$$

According to Proposition 3.2, there is a canonical injection $\text{Pic}^0(C)[2] \hookrightarrow V^\vee$ of finite k -groups. Dualizing, we obtain a surjection $V \rightarrow \text{Pic}^0(C)[2]$, and we push out the above extension by this surjection to obtain a central extension

$$1 \rightarrow \mathbb{G}_m \rightarrow \tilde{E} \rightarrow V \rightarrow 1.$$

The commutator pairing of \tilde{E} descends to the natural symplectic form on V (since this is true for $\tilde{H}_{\mathcal{L}}$, by Lemma 1.7, and the kernel of $V \rightarrow \text{Pic}^0(C)[2]$ is exactly the radical of this symplectic form). Since V is endowed with a Γ_k -invariant quadratic form $q : V \rightarrow \mathbb{F}_2$, we can define a character $\chi_q : \tilde{E} \rightarrow \mathbb{G}_m$ by the formula $\tilde{e} \mapsto (-1)^{q(\tilde{e})} \tilde{e}^2$. This makes sense since, for any $\tilde{e} \in \tilde{E}$, we have $\tilde{e}^2 \in \mathbb{G}_m$. Taking $\tilde{V} = \ker \chi_q$ then gives the desired extension

$$1 \rightarrow \{\pm 1\} \rightarrow \tilde{V} \rightarrow V \rightarrow 1.$$

(This is a slight variant on the procedure leading to the extension (1-1).) Note that if $W = H^0(\text{Pic}^0(C), \mathcal{L})$, then there is a natural homomorphism of k -groups $\tilde{V} \rightarrow \text{GL}(W)$. Indeed, the group $\tilde{H}_{\mathcal{L}}$ acts on W by definition by pullback of sections; we can then pull back this action along the homomorphism $\tilde{V} \rightarrow \tilde{H}_{\mathcal{L}}$. If $k = k^s$, then this is an 8-dimensional irreducible representation of the abstract group $\tilde{V}(k^s)$, which sends -1 to $-\text{id}_{W_{k^s}}$.

In Section 2 we have associated to the triple (Λ, \tilde{V}, W) a simple adjoint group H_0 of type E_7 , together with a stable involution θ and maximal torus $T \subset H_0$, and a representation of $\mathfrak{g}_0 = \mathfrak{h}_0^\theta$ on W . By definition, the torus T is canonically isomorphic to $\text{Hom}(\Lambda, \mathbb{G}_m)$, and θ acts on it by $t \mapsto t^{-1}$. The group H_0 is split; in fact, since \mathfrak{g}_0 is a form of \mathfrak{sl}_8 with an 8-dimensional representation which is defined over k , \mathfrak{g}_0 is split. The Lie algebras \mathfrak{g}_0 and \mathfrak{h}_0 are semisimple Lie algebras of rank 7, so this implies that \mathfrak{h}_0 must also be split.

By Proposition 1.9, there is an isomorphism $\varphi : H \rightarrow H_0$ satisfying $\theta_0\varphi = \varphi\theta$. This isomorphism is defined uniquely up to $H^\theta(k)$ -conjugacy. The group H^θ is disconnected, with two connected components; the nontrivial component acts on the connected component $G = (H^\theta)^\circ$ by outer automorphisms. In order to pin down the isomorphism φ up to $G(k)$ -conjugacy, we observe that $\varphi^*(W)$ is an irreducible 8-dimensional representation of \mathfrak{g} , which is therefore isomorphic either to the fixed “standard representation” or its dual. After possibly modifying φ , we can therefore assume that φ carries W to the standard representation of \mathfrak{g} . The isomorphism φ is then indeed determined uniquely up to $G(k)$ -conjugacy.

It follows that the orbit $G(k) \cdot \varphi^{-1}(\kappa_C) \in G(k) \setminus Y(k)$ is well-defined. (Note, in particular, that κ_C is defined only up to inversion, but that θ acts on κ_C by inversion and lies in $G(k)$ — in fact in the center of $G(k)$ — so the orbit is independent of any choices.) To complete the proof in this case, we must show that $\varphi^{-1}(\kappa_C)$ is stable (equivalently, regular semisimple in T), and that the map we have defined is a bijection if $k = k^s$. This follows from the discussion preceding the proof of this theorem, and Theorem 3.4.

Let us now treat the E_6 case. The inverse image $\pi^{-1}(\ell) = e \cup f$ of the bitangent ℓ at P in the surface S determines the root lattice Λ_ℓ , and we set $V = \Lambda_\ell/2\Lambda_\ell$. The natural symplectic pairing on V is nondegenerate, and the quadratic form $q : V \rightarrow \mathbb{F}_2$ arising from the form on Λ_ℓ agrees with the quadratic form on V arising from the isomorphism $V \cong \text{Pic}^0(C)[2]$ and the odd theta characteristic κ corresponding to ℓ , by Proposition 3.3. We then have the Heisenberg group $\tilde{H}_{\mathcal{L}}$:

$$1 \rightarrow \mathbb{G}_m \rightarrow \tilde{H}_{\mathcal{L}} \rightarrow \text{Pic}^0(C)[2] \rightarrow 1.$$

Pushing out by the isomorphism $V \cong \text{Pic}^0(C)[2]$, we obtain an extension (isomorphic to $\tilde{H}_{\mathcal{L}}$)

$$1 \rightarrow \mathbb{G}_m \rightarrow \tilde{E} \rightarrow V \rightarrow 1.$$

We define a character $\chi_q : \tilde{E} \rightarrow \mathbb{G}_m$ by the formula $\tilde{e} \mapsto (-1)^{q(\tilde{e})}\tilde{e}^2$, and set $\tilde{V} = \ker \chi_q$. Then \tilde{V} is an extension

$$1 \rightarrow \{\pm 1\} \rightarrow \tilde{V} \rightarrow V \rightarrow 1.$$

We define $W = H^0(\text{Pic}^0(C), \mathcal{L})$; then \tilde{V} acts on W through the homomorphism $\tilde{V} \rightarrow \tilde{H}_{\mathcal{L}}$. Applying the constructions of Section 2 to the triple $(\Lambda_\ell, \tilde{V}, W)$, we obtain an adjoint group H_0 of type E_6 equipped with a stable involution θ_0 , together with an action of the Lie algebra $\mathfrak{g}_0 = \mathfrak{h}_0^{\theta_0}$ on W . Since \mathfrak{g}_0 is an inner form of \mathfrak{sp}_8 and has an 8-dimensional representation defined over k , it must be split. This implies that H_0 has split rank at least 4; by the classification of forms of E_6 [Tits 1966, pp. 58–59], we see that H_0 must be quasisplit, and split by a quadratic extension. This quadratic extension is the smallest extension splitting the Galois action on $\Lambda_\ell^\vee/\Lambda_\ell$. Since the geometric irreducible components e and f of $\pi^{-1}(\ell)$ are defined over k , this action is trivial, and we see that H_0 is also split.

Applying Proposition 1.9 once more, we see that there is an isomorphism $\varphi_e : H \rightarrow H_0$ such that $\varphi_e\theta = \theta_0\varphi_e$. This isomorphism is determined up to $H^\theta(k) = G(k)$ -conjugacy (as H^θ is connected in this case). Moreover, we can assume that, under the isomorphism φ_e , the minuscule representation of H_0 with weights in $\Lambda_\ell^\vee/\Lambda_\ell$ corresponding to e is identified with the “standard representation” of H .

The orbit $G(k) \cdot \varphi_e^{-1}(\kappa_C)$ is then well-defined: reversing the roles of e and f in our construction replaces $\kappa_C = \kappa(C, P, e)$ by $\kappa(C, P, f) = \kappa(C, P, e)^{-1}$, and θ_0 is an outer automorphism, acting on $\Lambda_\ell^\vee/\Lambda_\ell \cong \mathbb{Z}/3\mathbb{Z}$ as multiplication by -1 , so we can take $\varphi_f = \varphi_e \circ \theta_0$. Then we have

$$G(k) \cdot \varphi_f^{-1}(\kappa(C, P, f)) = G(k) \cdot \varphi_f^{-1}(\theta_0(\kappa(C, P, e))) = G(k) \cdot \varphi_e^{-1}(\kappa(C, P, e)).$$

This shows that we have constructed a well-defined map $\mathcal{S}(k) \rightarrow G(k) \backslash X(k)$. The rest of the theorem in this case follows from the discussion preceding the proof of this theorem, and Theorem 3.4.

The arguments in the Lie algebra cases are very similar, with maximal tori replaced by Cartan subalgebras. We omit the details. □

Fix $x = (C, P, \dots) \in \mathcal{S}(k)$. Let $\pi : X \rightarrow X//G$ denote the natural quotient map, and let $X_x = \pi^{-1}\pi(x)$. Then we know that $X_x \subset X^s$ consists of a single G -orbit (see Section 1D), but $X_x(k)$ may break up into several $G(k)$ -orbits which all become conjugate over k^s . Let J_x denote the Jacobian of C . We now state our second main theorem, which shows how to construct elements of $G(k) \backslash X_x(k)$ from $J_x(k)$:

Theorem 3.6. *With notation as above, there is a canonical map*

$$J_x(k)/2J_x(k) \hookrightarrow G(k) \backslash X_x(k). \tag{3-2}$$

It is functorial in k in the obvious sense.

The map (3-2) will extend the map of Theorem 3.5, in the sense that the image of the identity element of $J_x(k)/2J_x(k)$ under (3-2) equals the image of $x \in \mathcal{S}(k)$ under (3-1).

Proof. The proof is a twist of the proof of Theorem 3.5, using the ideas of Section 1C. We treat first the E_7 case. Let $A \in J_x(k)$ be a rational point. Choose $B \in J_x(k^s)$ such that $[2](B) = A$. Then the field of definition of the line bundle $t_B^* \mathcal{L}$ is equal to k , and we choose a bundle \mathcal{L}_B over k which becomes isomorphic to $t_B^* \mathcal{L}$ over k^s . We continue to denote $\Lambda = \text{Pic}(\mathcal{S}_{k^s})$, $V = \Lambda/2\Lambda$, and associate to \mathcal{L}_B the Heisenberg group $\tilde{H}_{\mathcal{L}_B}$, which fits into an exact sequence

$$1 \rightarrow \mathbb{G}_m \rightarrow \tilde{H}_{\mathcal{L}_B} \rightarrow J_x[2] \rightarrow 1.$$

Arguing exactly as in the proof of Theorem 3.5, we obtain an extension

$$1 \rightarrow \{\pm 1\} \rightarrow \tilde{V}_B \rightarrow V \rightarrow 1,$$

together with a homomorphism $\tilde{V}_B \rightarrow \tilde{H}_{\mathcal{L}_B}$ through which the group \tilde{V}_B acts on the space $W_B = H^0(J_x, \mathcal{L}_B)$, an 8-dimensional k -vector space. Over k^s , this defines an irreducible representation of the abstract group $\tilde{V}_B(k^s)$.

Using the constructions of Section 2, we associate to the triple $(\Lambda, \tilde{V}_B, W_B)$ a group H_B with involution θ_B , maximal torus $T_B \cong \text{Hom}(\Lambda, \mathbb{G}_m)$, and an action of the Lie algebra $\mathfrak{g}_B = \mathfrak{h}_B^{\theta_B}$ on W_B . Just as in the proof of Theorem 3.5, the existence of W_B implies that the groups H_B and G_B are split, and $T_B(k)$ has a point κ_C , well-defined up to inversion. By Proposition 1.9, we can find an isomorphism $\varphi_B : H \rightarrow H_B$ which intertwines θ and θ_B , and under which W_B corresponds to the “standard representation” of $\mathfrak{g} \cong \mathfrak{sl}_8$. The choice of φ_B is then unique up to the action of $G(k)$, and we associate to the point B the orbit $G(k) \cdot \varphi_B^{-1}(\kappa_C) \subset Y_x(k)$.

We observe that if $A = B = 0$, the identity of $J_x(k)$, then the above construction reduces to that of Theorem 3.5. In general, we must show that the orbit $G(k) \cdot \varphi_B^{-1}(\kappa_C) \subset P_x(k)$ depends only on the image of A in $J_x(k)/2J_x(k)$ (and not on the choice of B), and that distinct elements of $J_x(k)/2J_x(k)$ give rise to distinct orbits. Let $\varphi_0^{-1}(\kappa_C) \in Y_x(k)$ be the point constructed in the proof of Theorem 3.5. Since $G(k^s)$ acts transitively on $P_x(k^s)$, a well-known principle asserts that there is a canonical bijection

$$G(k) \setminus Y_x(k) \cong \ker(H^1(k, Z_G(\varphi_0^{-1}(\kappa_C))) \rightarrow H^1(k, G)), \tag{3-3}$$

under which the base orbit $G(k) \cdot \varphi_0^{-1}(\kappa_C)$ corresponds to the marked element; see, for example, [Bhargava and Gross 2014, Proposition 1]. By [Thorne 2013, Corollary 2.10] and Proposition 3.2, there is a canonical isomorphism

$$Z_G(\varphi_0^{-1}(\kappa_C)) \cong Z_{G_0}(\kappa_C) \cong \text{image}(V \rightarrow V^\vee) \cong J_x[2].$$

We will show that under the composite

$$G(k) \setminus Y_x(k) \hookrightarrow H^1(k, Z_G(\varphi_0^{-1}(\kappa_C))) \cong H^1(k, J_x[2]),$$

the orbit $G(k) \cdot \varphi_B^{-1}(\kappa_C)$ is mapped to the image of A under the 2-descent homomorphism of Section 1C.

The pullback t_B^* defines a canonical isomorphism $\tilde{V} \cong \tilde{V}_B$ over k^s by the formula (1-2). This gives rise to an isomorphism of triples $F : (H_0, \theta_0, T_0) \cong (H_B, \theta_B, T_B)$ which induces the identity on $\text{Hom}(\Lambda, \mathbb{G}_m)$ under the identification of this torus with T_0 and T_B . According to Lemma 2.4, we can identify $F^{-1}\sigma F$ with an element of V^\vee . Lemma 1.8 now implies that this element in fact lies in the image of the homomorphism $V \rightarrow V^\vee$ and, under the identification of this image with $J_x[2]$, is identified with the cocycle $\sigma \mapsto \sigma B - B$. This identity of cocycles implies the desired identity of cohomology classes, and completes the proof in this case.

The proof of the theorem in the remaining cases, E_6 , e_7 , and e_6 , simply requires analogous modifications to the proof of Theorem 3.5. We work out the E_6 case here. Let us take $x = (C, P) \in \mathcal{S}(k)$, so that P is a point such that $T_P C = \ell$ is a bitangent in the canonical embedding of the curve C . The root lattice Λ_ℓ is defined, and we define $V = \Lambda_\ell/2\Lambda_\ell$. The natural symplectic pairing on V is nondegenerate, and the quadratic form $q : V \rightarrow \mathbb{F}_2$ arising from the form on Λ_ℓ agrees with the quadratic form on V arising from the isomorphism $V \cong J_x[2]$ and the odd theta characteristic κ corresponding to ℓ , by Proposition 3.3. Let $A \in J_x(k)$, and choose a point $B \in J_x(k^s)$ with $[2](B) = A$. Let \mathcal{L}_B be a descent of the line bundle $t_B^* \mathcal{L}$ to k . We then have the Heisenberg group $\tilde{H}_{\mathcal{L}_B}$:

$$1 \rightarrow \mathbb{G}_m \rightarrow \tilde{H}_{\mathcal{L}_B} \rightarrow J_x[2] \rightarrow 1.$$

Arguing exactly as in the proof of Theorem 3.5, we obtain an extension

$$1 \rightarrow \{\pm 1\} \rightarrow \tilde{V}_B \rightarrow V \rightarrow 1,$$

and \tilde{V}_B acts on the 8-dimensional k -vector space $W_B = H^0(J_x, \mathcal{L}_B)$ through a homomorphism $\tilde{V}_B \rightarrow \tilde{H}_{\mathcal{L}_B}$. We can apply the constructions of Section 2 to the triple $(\Lambda_\ell, \tilde{V}_B, W_B)$ to obtain a group H_B with involution θ_B , maximal torus $T_B \cong \text{Hom}(\Lambda, \mathbb{G}_m)$, and an action of the Lie algebra $\mathfrak{g}_B = \mathfrak{h}_B^{\theta_B}$ on W_B . The existence of W_B implies that the groups H_B and G_B are split, and $T_B(k)$ has a point $\kappa_C = \kappa(C, P, e)$ which depends on a choice of component e of $\pi^{-1}(\ell) = e \cup f$. By Proposition 1.9, we can find an isomorphism $\varphi_{B,e} : H \rightarrow H_B$ which intertwines θ and θ_B , and under which the “standard representation” of \mathfrak{h} corresponds to the minuscule representation of \mathfrak{h}_B corresponding to the class of e in $\Lambda_\ell^\vee \vee / \Lambda_\ell$. The choice of $\varphi_{B,e}$ is then unique up to the action of $G(k)$, and we associate to the point B the orbit $G(k) \cdot \varphi_{B,e}^{-1}(\kappa(C, P, e)) \subset Y_x(k)$. Just as in the E_7 case, we

can check that the map $B \mapsto G(k) \cdot \varphi_{B,e}^{-1}(\kappa(C, P, e))$ descends to an injection $J_x(k)/2J_x(k) \hookrightarrow G(k) \setminus Y_x(k)$. This completes the proof. \square

3B. An example. To illustrate our theorem, we describe explicitly what happens in the ϵ_6 case, when $k = \mathbb{R}$. Then the reference group H is a split adjoint group of type E_6 over \mathbb{R} , $H^\theta = G$ is isomorphic to PSp_8 , a projective symplectic group in 8 variables, and $V = \mathfrak{h}^{d\theta=-1}$ is a 42-dimensional irreducible subrepresentation of $\wedge^4(8)$. The corresponding family of curves is the family (C, P, t) of smooth nonhyperelliptic genus-3 curves, equipped with a point P which is a hyperflex in the canonical embedding, and a nonzero Zariski tangent vector $t \in T_P C$. It consists of the smooth members in the family

$$y^3 = x^4 + y(p_2x^2 + p_5x + p_8) + p_6x^2 + p_9x + p_{12}$$

(here we are using the affine chart which makes P the unique point at infinity). For each tuple

$$(p_2, p_5, p_8, p_6, p_9, p_{12}) \in \mathbb{R}^6$$

for which this curve is smooth, we can write down the following data:

- Topological invariants of the curve $C(\mathbb{R}) \subset \mathbb{P}^2(\mathbb{R})$: following [Gross and Harris 1981], we write $n(C)$ for the number of connected components of $C(\mathbb{R})$, and $a(C) = 0$ or 1 depending on whether or not $C(\mathbb{C}) - C(\mathbb{R})$ is disconnected.
- A stable G -orbit $V_x \subset V^s$, and an $H(\mathbb{R})$ -conjugacy class of maximal tori $T \subset H$ (T is the stabilizer in H of the base orbit in $V_x(\mathbb{R})$, which is regular semisimple).
- An injection $J(\mathbb{R})/2J(\mathbb{R}) \hookrightarrow G(\mathbb{R}) \setminus V_x(\mathbb{R})$, where J is the Jacobian of the curve C .

The isomorphism classes of tori in H are in bijection with the conjugacy class of elements in the Weyl group W of order 2 [Reeder 2011, §6]. It turns out that these correspond to the possible topological types of the curve $C(\mathbb{R})$ in $\mathbb{P}^2(\mathbb{R})$, as shown in Table 1. The table should be interpreted as follows: suppose that a curve C has the given invariants. (It follows from the table on [Gross and Harris 1981, p. 174] that the only possible values for the pair $(n(C), a(C))$ are the ones listed in Table 1.) Then the real structure on the torus T is the one determined by the Weyl element in the left-hand column, and the data in the remaining three columns is as given. Here $s_1, s_2, s_3 \in W$ are commuting simple reflections, and $\tau \in W$ may be constructed as follows: choose a D_4 root system inside Λ . Then $-1 \in W(D_4)$, and τ is the element that acts as -1 on the span of the D_4 roots, and as $+1$ on their orthogonal complement. The elements $1, s_1, s_1s_2, s_1s_2s_3$, and τ are pairwise nonconjugate in W and every involution in W is conjugate to one of these. (For the classification of conjugacy classes of involutions in Weyl groups, see [Richardson 1982a].)

conjugacy class	$n(C)$	$a(C)$	number of real bitangents	$\#J(\mathbb{R})/2J(\mathbb{R})$	$\#G(\mathbb{R}) \setminus V_x(\mathbb{R})$
1	4	0	28	2^3	36
s_1	3	1	16	2^2	10
s_1s_2	2	1	8	2	3
$s_1s_2s_3$	1	1	4	1	1
τ	2	0	4	2	3

Table 1. Correspondence between conjugacy class of elements in the Weyl group of order 2 and possible topological types of the curve $C(\mathbb{R})$ in $\mathbb{P}^2(\mathbb{R})$.

One can check explicitly that each of the above combinations of $(n(C), a(C))$ does indeed occur. Table 1 can be verified as follows. It follows from our theory that there is an isomorphism $J[2](\mathbb{C}) \cong \Lambda_\ell/2\Lambda_\ell$ under which the action σ of complex conjugation corresponds to the action of an involution $w \in W(\Lambda_\ell) = W$ and which identifies the Weil pairing on the left-hand side with the natural symplectic pairing on the right. On the other hand, [Gross and Harris 1981, Proposition 4.4] shows that the data of the pair $(J[2](\mathbb{C}), \sigma)$ (as a symplectic \mathbb{F}_2 -vector space with involution) is sufficient to recover $n(C)$ and $a(C)$. A calculation shows that the Weyl involutions biject with the possible choices for the pair $(n(C), a(C))$. This determines the number of real bitangents and the quantity $\#J(\mathbb{R})/2J(\mathbb{R})$.

We justify the final column using the results in the Appendix. The set $G(\mathbb{R}) \setminus V_x(\mathbb{R})$ is in canonical bijection with the set $\ker(H^1(\mathbb{R}, J[2]) \rightarrow H^1(\mathbb{R}, G))$, the marked element corresponding to the trivial element of $J(\mathbb{R})/2J(\mathbb{R})$. We analyze this kernel using the following diagram of \mathbb{R} -groups with exact rows, whose existence is asserted by the main result in the Appendix:

$$\begin{array}{ccccccc}
 1 & \longrightarrow & \mu_2 & \longrightarrow & \mathrm{Sp}_8 & \longrightarrow & \mathrm{PSP}_8 \longrightarrow 1 \\
 & & \uparrow & & \uparrow & & \uparrow \\
 1 & \longrightarrow & \mu_2 & \longrightarrow & \tilde{V} & \longrightarrow & J[2] \longrightarrow 1
 \end{array}$$

Here \tilde{V} is the extension used in the proof of Theorem 3.5; it is a subgroup of the Heisenberg group $\tilde{H}_{\mathcal{L}}$. Using the triviality of the set $H^1(\mathbb{R}, \mathrm{Sp}_8)$, we get an identification

$$G(\mathbb{R}) \setminus V_x(\mathbb{R}) \cong \ker(H^1(\mathbb{R}, J[2]) \rightarrow H^1(\mathbb{R}, G)) \cong \ker(H^1(\mathbb{R}, J[2]) \rightarrow H^2(\mathbb{R}, \mu_2)),$$

where the arrow

$$q : H^1(\mathbb{R}, J[2]) \rightarrow H^2(\mathbb{R}, \mu_2) \cong \mathbb{Z}/2\mathbb{Z}$$

is the connecting map arising from the bottom row of the above commutative diagram. (Note that we are working here with nonabelian Galois cohomology; the

connecting map is defined, because μ_2 is central, but it need not be a homomorphism of groups.)

Tate duality gives a perfect pairing on $H^1(\mathbb{R}, J[2])$, with respect to which $J(\mathbb{R})/2J(\mathbb{R})$ is a maximal isotropic subspace. The map q is a quadratic refinement of this pairing, in the sense of Section 1A, which is identically zero on the subspace $J(\mathbb{R})/2J(\mathbb{R})$ (see [Poonen and Rains 2012, Corollary 4.7]). It follows that $a(q) = 0$, and the set $q^{-1}(0)$ has $2^{g-1}(2^g + 1)$ elements, where $g = \dim_{\mathbb{F}_2} J(\mathbb{R})/2J(\mathbb{R})$. This leads to the final column in Table 1.

Appendix: A converse to Lurie’s functorial construction of simply laced Lie algebras

by Tasho Kaletha

In Section 2 a construction due to Lurie was recalled, which associates in a functorial way a semisimple Lie algebra \mathfrak{h} to a simply laced root lattice Λ equipped with an extension \tilde{V} of $V = \Lambda/2\Lambda$ by $\{\pm 1\}$. In fact, the construction produces not just \mathfrak{h} , but also some additional structure, including a Cartan subalgebra \mathfrak{t} . This construction was, moreover, refined in several ways. It was shown that an action of the Galois group of a field k on \tilde{V} is translated to a k -structure on \mathfrak{h} ; it was shown that \mathfrak{h} comes equipped with a stable involution θ (i.e., an involution satisfying the first condition of Proposition 1.9); and finally a construction was described that produces from a rational representation ρ of the finite algebraic k -group \tilde{V} with $\rho(-1) = -1$ a rational representation $d\pi$ of the Lie algebra $\mathfrak{g} = \mathfrak{h}^\theta$.

The purpose of this appendix is to provide a converse to this refinement of Lurie’s construction. The basic question is: given \mathfrak{h} , \mathfrak{t} , and θ , is it possible to recover the extension \tilde{V} in a concrete way? That this should be the case, and in fact where the extension is to be found, was suggested to us by Jack Thorne. His idea was that the extension \tilde{V} should be the preimage in G_{sc} of the 2-torsion subgroup of T_{sc} , where T_{sc} is the maximal torus of the simply connected group H_{sc} with Lie algebra \mathfrak{h} given by the Cartan subalgebra \mathfrak{t} , and G_{sc} is the simply connected group with Lie algebra \mathfrak{g} . In this appendix, we will show that this preimage is indeed an extension of V by $\{\pm 1\}$ and we will, moreover, construct an isomorphism from this extension to \tilde{V} that preserves the action of the Galois group of k and intertwines the representations ρ and π .

We thank Jack Thorne for sharing with us this interesting question and for including our results in his paper.

A1. Statement of two propositions. Let k be a field of characteristic 0 and k^s a fixed separable closure, and let $\Gamma_k = \text{Gal}(k^s/k)$. Let Λ be a finite free \mathbb{Z} -module equipped with a symmetric bilinear form $\langle \cdot, \cdot \rangle : \Lambda \otimes \Lambda \rightarrow \mathbb{Z}$ and satisfying the following conditions:

- $\text{rk } \Lambda > 1$.
- For any nonzero $\lambda \in \Lambda$, the value $\langle \lambda, \lambda \rangle$ is a positive even integer.
- The set $\Gamma = \{\lambda \in \Lambda \mid \langle \lambda, \lambda \rangle = 2\}$ generates Λ .

As discussed in [Lurie 2001], these are precisely the root lattices of simply laced root systems. Here we are excluding the system A_1 . The subset $\Gamma \subset \Lambda$ is the set of roots. We shall place the additional assumption that Γ is irreducible. This assumption is made just for convenience and can easily be removed.

Write $q(\lambda) = \frac{1}{2}\langle \lambda, \lambda \rangle$, this is a quadratic form. Let $V = \Lambda/2\Lambda$ and let

$$1 \rightarrow \{\pm 1\} \rightarrow \tilde{V} \rightarrow V \rightarrow 0$$

be an extension of groups (we write the group law of \tilde{V} multiplicatively) with the property that, for each $\tilde{v} \in \tilde{V}$ and its image $v \in V$, the equality $\tilde{v}^2 = (-1)^{q(v)}$ holds. This equation characterizes the isomorphism class of this extension.

Assume we are given an action of Γ_k on Λ that preserves $\langle \cdot, \cdot \rangle$, as well as an action of Γ_k on \tilde{V} that preserves the subgroup $\{\pm 1\}$, such that the two actions on V induced from these coincide. Let $\tilde{\Lambda} = \Lambda \times_V \tilde{V}$ and let $\tilde{\Gamma} \subset \tilde{\Lambda}$ be the preimage of Γ . The extension $\tilde{\Lambda}$ of Λ by $\{\pm 1\}$ inherits an action of Γ_k and this action preserves $\tilde{\Gamma}$.

Let \mathfrak{h} be the Lie algebra associated to this data as described in Section 2. It comes equipped with a Cartan subalgebra \mathfrak{t} and a map $\tilde{\Gamma} \rightarrow \mathfrak{h}$ sending each $\tilde{\gamma}$ to a nonzero root vector $X_{\tilde{\gamma}} \in \mathfrak{h}_{\tilde{\gamma}}$ and having the properties:

- $X_{-\tilde{\gamma}} = -X_{\tilde{\gamma}}$.
- $[X_{\tilde{\gamma}}, X_{\tilde{\gamma}'}] = X_{\tilde{\gamma}\tilde{\gamma}'}$ if $\gamma + \gamma' \in \Gamma$ (by assumption $\tilde{\gamma}\tilde{\gamma}' \in \tilde{\Gamma}$).
- $[X_{\tilde{\gamma}}, X_{\tilde{\gamma}'}] = (\tilde{\gamma}\tilde{\gamma}')H_{\gamma}$ if $\gamma' = -\gamma$, where $H_{\gamma} \in \mathfrak{t}$ is the coroot for γ (by assumption $\tilde{\gamma}\tilde{\gamma}' \in \{\pm 1\}$).

Let $H = \text{Aut}(\mathfrak{h})^\circ$ be the corresponding adjoint group, H_{sc} its simply connected cover, and θ the involution of \mathfrak{h} which acts by -1 on \mathfrak{t} and by $\theta(X_{\tilde{\gamma}}) = -X_{\tilde{\gamma}^{-1}}$ on the root subspaces. It induces an involution on H and H_{sc} as well and this involution acts by inversion of the maximal tori T and T_{sc} whose Lie algebra is \mathfrak{t} . Let $\mathfrak{g} = \mathfrak{h}^\theta$ be the fixed Lie subalgebra and $G = H^{\theta, \circ}$ the connected component of the fixed subgroup. Let $G' = H_{\text{sc}}^\theta$. According to [Steinberg 1968, Theorem 8.1] G' is connected. Its image in H is equal to G . Since θ commutes with the action of Γ_k , the groups G and G' are defined over k .

Proposition A.1. *The group G' is semisimple and its fundamental group has order 2.*

Let G_{sc} be the simply connected cover of G . We will from now on denote the fundamental group of G' by $\{\pm 1\} \subset G_{\text{sc}}$. For a root $\gamma \in \Gamma$, let γ^\vee be the corresponding coroot. The map

$$V \rightarrow T_{\text{sc}}, \quad [\gamma] \mapsto \gamma^\vee(-1)$$

identifies V with the 2-torsion subgroup of T_{sc} and this subgroup belongs to G' . We form the pullback extension

$$\begin{array}{ccccccc}
 1 & \longrightarrow & \{\pm 1\} & \longrightarrow & G_{sc} & \longrightarrow & G' \longrightarrow 1 \\
 & & \parallel & & \uparrow & & \uparrow \\
 1 & \longrightarrow & \{\pm 1\} & \longrightarrow & X & \longrightarrow & V \longrightarrow 1
 \end{array}$$

This extension inherits an action of Γ_k .

Finally, given a rational representation $\rho: \tilde{V} \rightarrow GL(W)$ of the algebraic k -group \tilde{V} on a finite-dimensional k -vector space W such that $\rho(-1) = -1$, we define a representation $d\pi: \mathfrak{g} \rightarrow \mathfrak{gl}(W)$ by $d\pi(X_{\tilde{\gamma}} - X_{\tilde{\gamma}^{-1}}) = \frac{1}{2}\rho(\tilde{\gamma})$, and let $\pi: G_{sc} \rightarrow GL(W)$ be the corresponding rational representation of G_{sc} . Recall that Proposition 2.3 asserts that $d\pi$ is indeed a Lie algebra representation.

Proposition A.2. *There exists an isomorphism of extensions $\Phi: \tilde{V} \rightarrow X$ which is Γ_k -equivariant and intertwines ρ with $\pi|_X$ for all representations ρ as above.*

A2. Proof of Proposition A.1. According to [Reeder et al. 2012, §5.3], the involution θ is stable and hence its conjugacy class is uniquely determined. A description of this conjugacy class for each Dynkin type is given in [Reeder et al. 2012, §8] in terms of Kac diagrams. The normalized Kac diagram of the stable involution contains a unique node with label 1, and all other nodes have label 0. According to [Reeder 2010, §3.7], this implies that the center of G is finite. Thus G , and hence also G' , is semisimple. Its Dynkin diagram is obtained by removing the unique node with label 1 from the Kac diagram of the stable involution. In order to prove that the fundamental group of G' has order 2, we argue as follows. According to [Reeder 2010, §3.7], the order of the center of G is given by b_ι , where ι is the index of the unique node with label 1 in the Kac diagram, and b_ι is an integer defined in [Reeder 2010, §3.3], which according to Theorem 3.7 in [loc. cit.] is equal to 2 if θ is inner and to 1 if θ is outer. Since θ acts by -1 on the Cartan subalgebra \mathfrak{t} , it is inner if and only if -1 belongs to the Weyl group of $(\mathfrak{t}, \mathfrak{h})$.

The kernel of the map $G' \rightarrow G$ is equal to $Z(H_{sc})^\theta$. Thus the center of G' has size $|Z(H_{sc})^\theta| \cdot b_\iota$. The proof will be complete once we show that this number is equal to one half of the connection index of the Dynkin diagram of G . This can be done by inspection of the individual cases A_n ($n > 1$), D_n , E_6 , E_7 , E_8 . We give the examples of the exceptional types, E_6 , E_7 , and E_8 , and leave the discussion of the classical types, A_n and D_n , to the reader.

For type E_6 , the Kac diagram of θ is given by the last row of Table 3 of [Reeder et al. 2012, §8.1] and has the form $0\ 0\ 0\ \leftarrow\ 0\ 1$, so G has type C_4 . Since θ is outer, G is adjoint. There are no θ -fixed points in the center of H_{sc} , thus $G' \cong \mathrm{PSp}_4$.

For type E_7 , the Kac diagram of θ is given by the last row of Table 4 and has the form $\begin{smallmatrix} 0 & 0 & 0 & 0 & 0 & 0 & 0 \\ & & & & & & 1 \end{smallmatrix}$, so G is of type A_7 . The center of G now has order 2, because

θ is inner, and, moreover, the fixed points of θ in $Z(H_{\text{sc}})$ also have order 2, so the center of G' has order 4.

For type E_8 , the Kac diagram of θ is given by the last row in Table 5 and has the form $\begin{smallmatrix} 1 & 0 & 0 & 0 & 0 & 0 & 0 & 0 \\ & 0 & & & & & & \end{smallmatrix}$, so G is of type D_8 . The center of G has order 2, because θ is inner. Since $Z(H_{\text{sc}}) = 1$, the center of G' also has order 2.

For the classical types, the relevant diagrams are those in row 2 of Table 10 (H is of type A_{2n} and G is of type B_n), row 3 of Table 11 with $k = n - 1$ (H is of type A_{2n-1} and G is of type D_n), row 3 of Table 14 for $k = n$ even (H is of type D_n and G is of type $D_{\frac{n}{2}} \times D_{\frac{n}{2}}$), and row 3 of Table 15 with $l = n$ odd (H is of type D_n and G is of type $B_{\frac{n-1}{2}} \times B_{\frac{n-1}{2}}$). Note that θ is inner for D_{even} and outer for A_n and D_{odd} .

A3. Proof of Proposition A.2.

A3.1. *The group SO_n .* We define the group SO_n to be the subgroup of SL_n fixed by the transpose-inverse automorphism. This group is semisimple when $n > 2$. For $n = 2$, it is noncanonically isomorphic to \mathbb{G}_m over k^s . One can specify an isomorphism by fixing a 4-th root of unity $i \in k^s$. Then we have

$$\mathbb{G}_m \rightarrow \text{SO}_2, \quad x \mapsto \frac{1}{2} \begin{bmatrix} x + x^{-1} & i(x - x^{-1}) \\ -i(x - x^{-1}) & x + x^{-1} \end{bmatrix}.$$

For future reference, we record the formula

$$\begin{bmatrix} a & b \\ -b & a \end{bmatrix}^2 = \begin{bmatrix} a^2 - b^2 & 2ab \\ -2ab & a^2 - b^2 \end{bmatrix}$$

for the squaring map $\text{SO}_2 \xrightarrow{(\)^2} \text{SO}_2$.

A3.2. *Construction of the isomorphism $\tilde{V} \rightarrow X$.* Choose a set of simple roots $\Delta \subset \Gamma$. The image Δ_V of Δ in V is a set of generators for this group, and the relations on this set are $2v = 0$ for all $v \in \Delta_V$. Let $\tilde{\Delta}$ be the preimage of Δ in $\tilde{\Lambda}$, and let $\tilde{\Delta}_V$ be the image of $\tilde{\Delta}$ in \tilde{V} . Then $\tilde{\Delta}_V$ is a set of generators for \tilde{V} , and the relations on this set are $\tilde{v}^2 = (-1)$ and $\tilde{v}\tilde{w} = (-1)^{\langle v, w \rangle} \tilde{w}\tilde{v}$.

We now define a map $\phi : \tilde{\Delta} \rightarrow X$. Given $\tilde{\gamma} \in \tilde{\Delta}$ we obtain a monomorphism $\eta_{\tilde{\gamma}} : \text{SL}_2 \rightarrow H_{\text{sc}}$ with θ -stable image that translates the action of θ on its image to the action of transpose-inverse on SL_2 . The fixed subgroup SO_2 of this action therefore lands in G' .

Lemma A.3. *The preimage of $\eta_{\tilde{\gamma}}(\text{SO}_2)$ in G_{sc} is connected.*

The proof of this lemma will be given in Section A3.6. Granting this lemma, it follows from Proposition A.1 that there exists a unique homomorphism $\phi_{\tilde{\gamma}} : \text{SO}_2 \rightarrow G_{\text{sc}}$

making the following diagram commute:

$$\begin{CD} \mathrm{SO}_2 @>\phi_{\tilde{\gamma}}>> G_{\mathrm{sc}} \\ @V(\)^2VV @VVV \\ \mathrm{SO}_2 @>\eta_{\tilde{\gamma}}>> G' \end{CD}$$

This homomorphism is injective. We let

$$\phi(\tilde{\gamma}) = \phi_{\tilde{\gamma}}\left(\begin{bmatrix} & 1 \\ -1 & \end{bmatrix}\right).$$

By the above diagram, the image of $\phi(\tilde{\gamma})$ in G' is equal to $\gamma^\vee(-1)$, which shows that $\phi(\tilde{\gamma}) \in X$. Moreover, $\phi(\tilde{\gamma})^2 = \phi_{\tilde{\gamma}}(-1)$ is a nontrivial element of G_{sc} whose image in G' is trivial, hence $\phi(\tilde{\gamma})^2 = -1$.

We thus obtain a map $\phi : \tilde{\Delta} \rightarrow X$ which descends to a map $\Phi : \tilde{\Delta}_V \rightarrow X$ and whose image contains a set of generators for X . We claim that Φ is Γ_k -equivariant. Given $\sigma \in \Gamma_k$, we have $\eta_{\sigma\tilde{\gamma}} = \sigma \circ \eta_{\tilde{\gamma}}$, and hence $\phi_{\sigma\tilde{\gamma}} = \sigma \circ \phi_{\tilde{\gamma}}$, where on the right sides of these equations σ denotes the action of σ on G' and G_{sc} , respectively. Thus $\phi(\sigma\tilde{\gamma}) = \sigma\phi(\tilde{\gamma})$ for all $\tilde{\gamma} \in \tilde{\Gamma}$ and this establishes the Γ_k -equivariance of Φ .

Our task is to show that Φ respects the relation $\tilde{v}\tilde{w} = (-1)^{(v,w)}\tilde{w}\tilde{v}$. Once this is done, it will extend to a surjective homomorphism $\Phi : \tilde{V} \rightarrow X$, which will then have to be bijective because its source and target have the same cardinality. It will furthermore be Γ_k -equivariant.

A3.3. *The isomorphism $\mathrm{PGL}_2 \rightarrow \mathrm{SO}_3$.* Consider the adjoint action of PGL_2 on its Lie algebra \mathfrak{sl}_2 . Fix a 4-th root of unity $i \in k^s$ as well as an element $\sqrt{2} \in k^s$. The basis

$$\sqrt{2}^{-1} \begin{bmatrix} 1 & \\ & -1 \end{bmatrix}, \quad (i\sqrt{2})^{-1} \begin{bmatrix} & 1 \\ -1 & \end{bmatrix}, \quad \sqrt{2}^{-1} \begin{bmatrix} & 1 \\ 1 & \end{bmatrix}$$

is an orthonormal basis for the symmetric bilinear form $\mathrm{tr}(AB)$ and provides an isomorphism $\mathrm{PGL}_2 \rightarrow \mathrm{SO}_3$ defined over k^s , which is explicitly given by

$$\begin{bmatrix} a & b \\ c & d \end{bmatrix} \mapsto (ad-bc)^{-1} \begin{bmatrix} ad+bc & i(ac+bd) & bd-ac \\ -i(ab+cd) & \frac{1}{2}(a^2+b^2+c^2+d^2) & \frac{i}{2}(a^2-b^2+c^2-d^2) \\ -(ab-cd) & \frac{i}{2}(c^2+d^2-a^2-b^2) & \frac{1}{2}(a^2-b^2-c^2+d^2) \end{bmatrix}.$$

Its derivative, $\mathfrak{sl}_2 \rightarrow \mathfrak{so}_3$, is given by

$$\begin{bmatrix} a & b \\ c & d \end{bmatrix} \mapsto \begin{bmatrix} 0 & i(b+c) & b-c \\ -i(b+c) & 0 & 2ia \\ c-b & -2ia & 0 \end{bmatrix}.$$

A3.4. *The relation $\tilde{v}\tilde{w} = (-1)^{\langle v, w \rangle} \tilde{w}\tilde{v}$.* In Section A3.2 we constructed a map $\Phi : \tilde{\Delta}_V \rightarrow X$. In order to show that it extends to an isomorphism $\tilde{V} \rightarrow X$, it remains to check that, for $\tilde{v}, \tilde{w} \in \tilde{\Delta}_V$ with images $v, w \in \Delta_V$, we have

$$\Phi(\tilde{v})\Phi(\tilde{w}) = (-1)^{\langle v, w \rangle} \Phi(\tilde{w})\Phi(\tilde{v}). \quad (\text{A-1})$$

Let $\tilde{\gamma}, \tilde{\delta} \in \tilde{\Gamma}$ be preimages of \tilde{v}, \tilde{w} , and let $\gamma, \delta \in \Delta$ be their images. We have either $\langle \gamma, \delta \rangle = 0$ or $\langle \gamma, \delta \rangle = -1$. In the first case, the cocharacters $\eta_{\tilde{\gamma}}$ and $\eta_{\tilde{\delta}}$ commute and hence their images are contained in a common maximal torus of G' . The preimage in G_{sc} of this maximal torus is a maximal torus of G_{sc} and contains the images of $\phi_{\tilde{\gamma}}$ and $\phi_{\tilde{\delta}}$, and we conclude that these two cocharacters also commute. This proves (A-1) in the case $\langle \gamma, \delta \rangle = 0$ and we are left with the case $\langle \gamma, \delta \rangle = -1$. Then the elements $\{X_{\tilde{\gamma} \pm 1}, X_{\tilde{\delta} \pm 1}, X_{(\tilde{\gamma}\tilde{\delta}) \pm 1}\}$ generate a subalgebra of \mathfrak{h} isomorphic to \mathfrak{sl}_3 . Even more, there is a preferred embedding $\mu_{\tilde{\gamma}, \tilde{\delta}} : \mathfrak{sl}_3 \rightarrow \mathfrak{h}$ given by

$$\begin{bmatrix} 0 & 1 \\ & 0 \\ & & 0 \end{bmatrix} \mapsto X_{\tilde{\gamma}}, \quad \begin{bmatrix} 0 & & \\ & 0 & 1 \\ & & 0 \end{bmatrix} \mapsto X_{\tilde{\delta}}, \quad \begin{bmatrix} 0 & & 1 \\ & 0 & \\ & & 0 \end{bmatrix} \mapsto X_{\tilde{\gamma}\tilde{\delta}}.$$

It integrates to an embedding $\mu_{\tilde{\gamma}, \tilde{\delta}} : \text{SL}_3 \rightarrow H_{\text{sc}}$. The embeddings $\eta_{\tilde{\gamma}}, \eta_{\tilde{\delta}} : \text{SL}_2 \rightarrow H_{\text{sc}}$ factor through $\mu_{\tilde{\gamma}, \tilde{\delta}}$ and give embeddings

$$\text{SO}_2 \rightarrow \text{SO}_3, \quad \begin{bmatrix} a & b \\ -b & a \end{bmatrix} \mapsto \begin{bmatrix} a & b \\ -b & a \\ & & 1 \end{bmatrix},$$

and

$$\text{SO}_2 \rightarrow \text{SO}_3, \quad \begin{bmatrix} a & b \\ -b & a \end{bmatrix} \mapsto \begin{bmatrix} 1 & & \\ & a & b \\ & -b & a \end{bmatrix}.$$

We compose these with the isomorphism $\text{SO}_3 \rightarrow \text{PGL}_2$ of Section A3.3, for which we fix the elements $i, \sqrt{2} \in k^s$ as discussed there. This gives two embeddings $\text{SO}_2 \rightarrow \text{PGL}_2$.

The first one is characterized by

$$\begin{bmatrix} a & b \\ -b & a \end{bmatrix} \mapsto \begin{bmatrix} \alpha & \beta \\ \beta & \alpha \end{bmatrix},$$

where $\alpha^2 + \beta^2 = a$ and $2i\alpha\beta = b$. The composition of this with the squaring map on SO_2 lifts to the map

$$\text{SO}_2 \rightarrow \text{SL}_2, \quad \begin{bmatrix} a & b \\ -b & a \end{bmatrix} \mapsto \begin{bmatrix} a & b/i \\ b/i & a \end{bmatrix}.$$

The image of $\begin{bmatrix} 0 & 1 \\ -1 & 0 \end{bmatrix}$ under this map is equal to $\begin{bmatrix} 0 & -i \\ -i & 0 \end{bmatrix}$.

The second embedding $\mathrm{SO}_2 \rightarrow \mathrm{PGL}_2$ is given by

$$\begin{bmatrix} a & b \\ -b & a \end{bmatrix} \mapsto \begin{bmatrix} \sqrt{a-ib} & \\ & \sqrt{a-ib}^{-1} \end{bmatrix}.$$

Note that this is well-defined with an arbitrary choice of $\sqrt{a-ib}$. Its composition with the squaring map on SO_2 lifts to the map

$$\mathrm{SO}_2 \rightarrow \mathrm{SL}_2, \quad \begin{bmatrix} a & b \\ -b & a \end{bmatrix} \mapsto \begin{bmatrix} a-ib & \\ & (a-ib)^{-1} \end{bmatrix}.$$

The image of $\begin{bmatrix} 0 & 1 \\ -1 & 0 \end{bmatrix}$ under this map is equal to $\begin{bmatrix} -i & \\ & i \end{bmatrix}$. The claim now follows from

$$\begin{bmatrix} 0 & -i \\ -i & 0 \end{bmatrix} \cdot \begin{bmatrix} -i & \\ & i \end{bmatrix} = - \begin{bmatrix} -i & \\ & i \end{bmatrix} \cdot \begin{bmatrix} 0 & -i \\ -i & 0 \end{bmatrix}.$$

A3.5. Intertwining property of $\Phi : \tilde{V} \rightarrow X$. Let $\rho : \tilde{V} \rightarrow \mathrm{GL}(W)$ be a rational representation of the finite algebraic k -group \tilde{V} on a finite-dimensional k -vector space W , having the property that $\rho(-1) = -1$. Let $\pi : G_{\mathrm{sc}} \rightarrow \mathrm{GL}(W)$ be the rational representation obtained from it. We want to show that Φ intertwines ρ with $\pi|_X$. It is enough to show that, for $\tilde{\gamma} \in \tilde{\Delta}$ with image $\tilde{v} \in \tilde{V}$, we have the following equality in $\mathrm{GL}(W)(k^s)$:

$$\pi(\Phi(\tilde{v})) = \rho(\tilde{v}).$$

Let $\gamma \in \Delta$ be the image of $\tilde{\gamma}$. Choose $\delta \in \Delta$ with $\langle \gamma, \delta \rangle = -1$ and let $\tilde{\delta} \in \tilde{\Delta}$ be a preimage. Let $\tilde{w} \in \tilde{V}$ be the image of $\tilde{\delta}$. Let $Q \subset \tilde{V}$ be the subgroup generated by \tilde{v}, \tilde{w} . It is isomorphic to the quaternion group.

Let $\mu_{\tilde{\gamma}, \tilde{\delta}} : \mathfrak{sl}_3 \rightarrow \mathfrak{h}$ be the embedding determined by $\tilde{\gamma}$ and $\tilde{\delta}$ as in Section A3.4. It determines an embedding $\mu_{\tilde{\gamma}, \tilde{\delta}} : \mathrm{SL}_3 \rightarrow H_{\mathrm{sc}}$.

Decompose $W = \bigoplus_{i=1}^n W_i$ under $\rho|_Q$ into irreducible representations over k^s . The condition $\rho(-1) = -1$ forces all W_i to be isomorphic to the unique 2-dimensional representation of Q . Moreover, by construction of $d\pi$, each subspace W_i of W is preserved by the action of $d\pi(\mu_{\tilde{\gamma}, \tilde{\delta}}(\mathfrak{so}_3))$, hence also by the action of $\pi(\mu_{\tilde{\gamma}, \tilde{\delta}}(\mathrm{SO}_3))$. We can thus focus on a single W_i . Choosing a suitable basis for W_i over k^s , we obtain from $\rho|_Q$ the embedding $Q \rightarrow \mathrm{SL}_2(k^s)$ given by

$$\tilde{v} \mapsto \begin{bmatrix} & -i \\ -i & \end{bmatrix}, \quad \tilde{w} \mapsto \begin{bmatrix} -i & \\ & i \end{bmatrix}, \quad \tilde{v}\tilde{w} \mapsto \begin{bmatrix} & 1 \\ -1 & \end{bmatrix}.$$

Reviewing the construction of $d\pi$, we see that the restriction to W_i of $d\pi \circ \mu_{\tilde{\gamma}, \tilde{\delta}}$ provides the isomorphism $\mathfrak{so}_3 \rightarrow \mathfrak{sl}_2$ given by

$$\begin{bmatrix} 0 & 1 \\ -1 & 0 \\ & & 0 \end{bmatrix} \mapsto \frac{1}{2} \begin{bmatrix} & -i \\ -i & \end{bmatrix}, \quad \begin{bmatrix} 0 & & \\ & 0 & 1 \\ & -1 & 0 \end{bmatrix} \mapsto \frac{1}{2} \begin{bmatrix} -i & \\ & i \end{bmatrix}, \quad \begin{bmatrix} 0 & & 1 \\ & 0 & \\ -1 & & 0 \end{bmatrix} \mapsto \frac{1}{2} \begin{bmatrix} & 1 \\ -1 & \end{bmatrix},$$

which one easily checks to be the inverse of the isomorphism of Section A3.3. Thus, the composition of the isomorphism $SL_2 \rightarrow Spin_3$ of Section A3.3 with the embedding $\mu_{\tilde{\gamma}, \tilde{\delta}} : Spin_3 \rightarrow G_{sc}$ provides a representation of SL_2 on W_i which in the chosen basis of W_i is given by the identity map $SL_2 \rightarrow SL_2$. However, the discussion of Section A3.4 shows that $\Phi(\tilde{v}) \in G_{sc}$ is the image of the element $\begin{bmatrix} & -i \\ -i & \end{bmatrix}$ under the composition of the isomorphism $SL_2 \rightarrow Spin_3$ of Section A3.3 with the embedding $\mu_{\tilde{\gamma}, \tilde{\delta}} : Spin_3 \rightarrow G_{sc}$. We conclude that $\rho(\tilde{v})$ and $\pi(\Phi(\tilde{v}))$ are represented by the same matrix in $SL_2(k^s) \subset GL(W_i)(k^s)$.

A3.6. Proof of Lemma A.3. We note first that the statement of the lemma is equivalent to the claim that the preimage of $\gamma^\vee(-1)$ in G_{sc} has order 4. Indeed, if the preimage of $\eta_{\tilde{\gamma}}(SO_2)$ in G_{sc} is connected, then identifying SO_2 with \mathbb{G}_m we obtain via pullback along $\eta_{\tilde{\gamma}}$ the nonsplit extension $1 \rightarrow \{\pm 1\} \rightarrow \mathbb{G}_m \rightarrow \mathbb{G}_m \rightarrow 1$, and the element $\gamma^\vee(-1)$ corresponds to the element -1 of the right copy of \mathbb{G}_m , which evidently has two preimages of order 4. On the other hand, if the preimage of $\eta_{\tilde{\gamma}}(SO_2)$ in G_{sc} is disconnected, then the corresponding extension is the split extension $1 \rightarrow \{\pm 1\} \rightarrow \{\pm 1\} \times \mathbb{G}_m \rightarrow \mathbb{G}_m \rightarrow 1$ and the element $-1 \in \mathbb{G}_m$ has two lifts of order 2.

We have the element $\tilde{\gamma} \in \tilde{\Gamma}$ and the corresponding element $\gamma \in \Gamma$. The chosen base Δ of Γ in the discussion of Section A3.2 will be unimportant. We first claim that there exists a maximal torus $S_{sc} \subset H_{sc}$, a Borel subgroup C containing S_{sc} , and a root α of H_{sc} with respect to S_{sc} such that θ preserves the pair (S_{sc}, C) as well as the root α and $\gamma^\vee(-1) = \alpha^\vee(-1)$. Indeed, choose a base Δ for Γ such that the corresponding Kostant cascade M (see [Kostant 2012]) contains γ . For each $\beta \in M$, choose a preimage $\tilde{\beta} \in \tilde{\Gamma}$. Let

$$g = \prod_{\beta \in M} \eta_{\tilde{\beta}} \begin{bmatrix} \frac{i}{2} & 1 \\ -\frac{1}{2} & -i \end{bmatrix} \in H_{sc}.$$

Then one checks that $S_{sc} := \text{Ad}(g)T_{sc}$ is normalized by θ . If we transport the action of θ on S_{sc} back to T_{sc} via the isomorphism $\text{Ad}(g)$, we obtain the automorphism $\text{Ad}(g^{-1}\theta(g)) \circ \theta$ and one computes that $\text{Ad}(g^{-1}\theta(g))$ acts as the product of reflections $\prod_{\beta \in M} s_\beta$, which according to [Kostant 2012, Proposition 1.10] represents the longest element of the Weyl group with respect to the basis Δ . This shows that $\text{Ad}(g^{-1}\theta(g)) \circ \theta$ preserves the basis Δ . It also evidently fixes the root γ . Let $\alpha = \text{Ad}(g)\gamma$, and let C be the Borel subgroup corresponding to the basis $\text{Ad}(g)\Delta$. Finally, $\alpha^\vee(-1) = \gamma^\vee(-1)$ follows from the fact that the element $g \in H_{sc}$ centralizes $\gamma^\vee(-1) \in H_{sc}$. Indeed, the image of $\eta_{\tilde{\beta}}$ for $\beta \in M \setminus \{\gamma\}$ centralizes the image of γ^\vee , while the image of $\eta_{\tilde{\gamma}}$ centralizes the element $\gamma^\vee(-1)$. The claim is proved.

We are now interested in showing that the preimage of $\alpha^\vee(-1)$ in G_{sc} has order 4. For this it is convenient to use again the equivalent formulation that the

preimage of $\alpha^\vee(\mathbb{G}_m)$ in G_{sc} is connected. By passing from γ to α we are now in the more advantageous situation that this preimage belongs to the preimage in G_{sc} of $G' \cap S_{sc} = S_{sc}^\theta$, which is a maximal torus. Call this maximal torus $\tilde{S} \subset G_{sc}$. We form the pullback diagram

$$\begin{array}{ccccccc} 1 & \longrightarrow & \{\pm 1\} & \longrightarrow & \tilde{S} & \longrightarrow & S_{sc}^\theta \longrightarrow 1 \\ & & \parallel & & \uparrow & & \alpha^\vee \uparrow \\ 1 & \longrightarrow & \{\pm 1\} & \longrightarrow & ? & \longrightarrow & \mathbb{G}_m \longrightarrow 1 \end{array}$$

and would like to show that the bottom extension is not split. Passing to character modules we obtain the pushout diagram

$$\begin{array}{ccccccc} 0 & \longrightarrow & X^*(S_{sc})_\theta & \longrightarrow & X^*(\tilde{S}) & \longrightarrow & \mathbb{Z}/2\mathbb{Z} \longrightarrow 0 \\ & & \downarrow \alpha^\vee & & \downarrow & & \parallel \\ 0 & \longrightarrow & \mathbb{Z} & \longrightarrow & X^*(?) & \longrightarrow & \mathbb{Z}/2\mathbb{Z} \longrightarrow 0 \end{array}$$

and would still like to show that the bottom extension is not split. This is equivalent to showing that for one, hence any, lift $\dot{1} \in X^*(?)$ of $1 \in \mathbb{Z}/2\mathbb{Z}$, we have $2\dot{1} \in \mathbb{Z} \setminus 2\mathbb{Z}$. This in turn is equivalent to showing that for one, hence any, lift $\dot{1} \in X^*(\tilde{S})$ of $1 \in \mathbb{Z}/2\mathbb{Z}$, we have $\alpha^\vee(2\dot{1}) \notin \alpha^\vee(2X^*(S_{sc})_\theta)$. Now $X^*(S_{sc})$ is the weight lattice of the group H_{sc} with respect to the torus S_{sc} . Since α^\vee is a coroot, we have $\alpha^\vee(X^*(S_{sc})_\theta) = \mathbb{Z}$. Our task is then to show that the image in \mathbb{Q} of $X^*(\tilde{S})$ under α^\vee is not contained in \mathbb{Z} . But $X^*(\tilde{S})$ is equal to the weight lattice of the group G_{sc} relative to the maximal torus \tilde{S} . We thus have to show that $\alpha^\vee \in X_*(S_{sc})^\theta$ does not belong to the coroot lattice of G' .

To that end, we need to describe the root and coroot systems of G' . Let $R \subset X^*(S_{sc})$ and $R^\vee \subset X_*(S_{sc})$ be the root and coroot systems of H_{sc} , and let $\Delta \subset R$ be the base given by the Borel subgroup C . We choose a nonzero root vector $X_\beta \in \mathfrak{h}_\beta$ for each $\beta \in \Delta$, subject to the condition $X_{\theta\beta} = \theta X_\beta$ provided $\theta\beta \neq \beta$. For $\beta \in \Delta$ satisfying $\theta\beta = \beta$, we have $\theta X_\beta = \epsilon X_\beta$ with $\epsilon \in \{1, -1\}$. Letting $\{\check{\omega}_\beta \mid \beta \in \Delta\}$ be the system of fundamental coweights, we set $s \in S$ to be the product of $\check{\omega}_\beta(-1)$ for all $\beta \in \Delta$ with $\theta\beta = \beta$ and $\theta X_\beta = -X_\beta$. Then $s \in S^\theta$ is of order 2 and $\theta = \text{Ad}(s)\theta_0$, with θ_0 an automorphism of H_{sc} preserving the splitting $(S_{sc}, C, \{X_\beta\})$. The root system of G' is a subset $R' \subset X^*(S_{sc}^\theta) = X^*(S_{sc})_\theta$. The duality between $X^*(S_{sc})$ and $X_*(S_{sc})$ induces a duality between $X^*(S_{sc})_\theta$ and $X_*(S_{sc})^\theta$. The coroot system of G' is a subset $R'^\vee \subset X_*(S_{sc})^\theta$. The system $R' \subset X^*(S_{sc})_\theta$ and its dual system $R'^\vee \subset X_*(S_{sc})^\theta$ can be described using the results of [Steinberg 1968], which are summarized in [Kottwitz and Shelstad 1999, §§1.1, 1.3]. As evident from the discussion there, the root system A_{2n} behaves differently from all other root systems,

a phenomenon that manifests itself in the occurrence of restricted roots of type R_2 and R_3 . It is therefore convenient to treat the special case of A_{2n} separately. Fortunately, this special case is rather easy.

Assuming that R is of type A_{2n} , we enumerate $\Delta = \{\alpha_1, \dots, \alpha_{2n}\}$ with $\theta(\alpha_i) = \alpha_{2n+1-i}$. Since θ has no fixed points in Δ , we have $\theta_0 = \theta$. Thus the projection of Δ to $X^*(S_{sc})_\theta$ forms a set of simple roots for R' . Let $\alpha'_i \in R'$ denote the projection of α_i . Then $\alpha'_1, \dots, \alpha'_{n-1}$ are of type R_1 , and the corresponding coroots are given by $\alpha_i^\vee = \alpha_i^\vee + \alpha_{2n+1-i}^\vee$. On the other hand, α'_n is of type R_2 and its coroot is given by $2(\alpha_n^\vee + \alpha_{n+1}^\vee)$. It follows that the coroot lattice of G' is the sublattice of $X_*(S_{sc})^\theta$ spanned by the points $\{\alpha_1^\vee + \alpha_{2n}^\vee, \dots, \alpha_{n-1}^\vee + \alpha_{n+2}^\vee, 2(\alpha_n^\vee + \alpha_{n+1}^\vee)\}$. On the other hand, we may assume without loss of generality that α is the highest root of R (by making the same assumption on the root γ , bearing in mind that the highest root is always part of the Kostant cascade). Then $\alpha^\vee = \alpha_1^\vee + \dots + \alpha_{2n}^\vee$ evidently does not belong to the coroot lattice of G' . This completes the discussion of the case A_{2n} .

The remaining root systems can now be treated uniformly, because all occurring restricted roots are of type R_1 . According to the discussion in [Kottwitz and Shelstad 1999, §1.3], the root system R' is given by the image of the set

$$\dot{R}' = \{\beta \in R \mid \theta\beta = \beta \Rightarrow \beta(s) = 1\}$$

under the natural projection $X^*(S_{sc}) \rightarrow X^*(S_{sc})_\theta$. For the description of R'^\vee , we have the following lemma.

Lemma A.4. *For any element of $\beta' \in R'$ represented by $\beta \in \dot{R}'$, the coroot $\beta'^\vee \in X_*(S_{sc})^\theta$ is given by*

$$\begin{cases} \beta^\vee & \text{if } \theta\beta = \beta, \\ \beta^\vee + \theta\beta^\vee & \text{if } \theta\beta \neq \beta. \end{cases} \tag{A-2}$$

Proof. Since β' is of type R_1 , we know that if $\theta\beta \neq \beta$ then $\theta\beta \perp \beta$. According to [Bourbaki 2002, Chapter VI, §1, No. 1], β'^\vee is the unique element of the dual space of $X^*(S_{sc})_\theta \otimes \mathbb{Q}$ with the properties $\langle \beta'^\vee, \beta' \rangle = 2$ and $s_{\beta', \beta'^\vee}(R') \subset R'$, where $s_{\beta', \beta'^\vee}(x) = x - \langle \beta'^\vee, x \rangle \beta'$ is the reflection determined by β', β'^\vee . We need to check that the elements given in the statement of the lemma satisfy these properties. The first property is immediate. For the second property we take $\beta_1, \beta_2 \in \dot{R}'$ and let $\beta'_1, \beta'_2 \in R'$ be their images. Let $\beta_1'^\vee \in X_*(S_{sc})^\theta$ be given by (A-2). We need to show that $s_{\beta'_1, \beta_1'^\vee}(\beta'_2) \in R'$. If β_2 is perpendicular to both β_1 and $\theta\beta_1$, or if $\beta'_1 = \pm\beta'_2$, then the claim is clear. We thus assume that this is not the case.

If β_1 is fixed by θ , then $s_{\beta'_1, \beta_1'^\vee}(\beta'_2)$ is the image of $s_{\beta_1, \beta_1^\vee}(\beta_2)$. This element of R belongs to \dot{R}' , because it is fixed by θ precisely when β_2 is, and in this case it kills s , since both β_1 and β_2 do.

If β_1 is not fixed by θ , but β_2 is, then we have $\langle \beta_1'^\vee + \theta\beta_1'^\vee, \beta_2 \rangle = 2\langle \beta_1'^\vee, \beta_2 \rangle = 2\epsilon \neq 0$ and conclude that $s_{\beta'_1, \beta_1'^\vee}(\beta'_2)$ is the image of $\beta_2 - 2\epsilon\beta_1$, which coincides with the

image of $\beta_2 - \epsilon\beta_1 - \epsilon\theta\beta_1$. The latter element belongs to R , because $\beta_1 \perp \theta\beta_1$. It is furthermore fixed by θ and kills s , so belongs to \dot{R}' .

Now assume that both β_1, β_2 are not fixed by θ . If $\langle \beta_1^\vee, \beta_2 \rangle$ and $\langle \theta\beta_1^\vee, \beta_2 \rangle$ are both nonzero and have opposite signs, then $s_{\beta_1', \beta_1^\vee}(\beta_2') = \beta_2'$. If $\langle \beta_1^\vee, \beta_2 \rangle$ and $\langle \theta\beta_1^\vee, \beta_2 \rangle$ are both nonzero and have the same sign $\epsilon \in \{1, -1\}$, then $s_{\beta_1', \beta_1^\vee}(\beta_2')$ is equal to the image of $\beta_2 - 2\epsilon\beta_1$, which coincides with the image of $\beta_2 - \epsilon\beta_1 - \epsilon\theta\beta_1$. As above, this element belongs to R . It is, moreover, not θ -fixed, thus belongs to \dot{R}' . It remains to consider the cases where exactly one of $\langle \beta_1^\vee, \beta_2 \rangle$ and $\langle \theta\beta_1^\vee, \beta_2 \rangle$ is nonzero. We will give the computation only in the case $\langle \beta_1^\vee, \beta_2 \rangle = 0, \langle \theta\beta_1^\vee, \beta_2 \rangle = -1$, the other cases being analogous. The element $s_{\beta_1', \beta_1^\vee}(\beta_2') \in X^*(S_{sc})_\theta$ is equal to the image of $\beta_2 + \beta_1 \in R$ and we claim that this element is not θ -fixed. If it were, we'd have $\beta_2 = \theta\beta_2 + \theta\beta_1 - \beta_1$ and applying $\langle \theta\beta_1^\vee, - \rangle$ we would obtain $-1 = 0 + 2 - 0$. \square

Armed with this lemma we complete the proof of [Lemma A.3](#) as follows. We have the element $\alpha^\vee \in X_*(S_{sc})^\theta$, which is a coroot for the group H_{sc} . We wish to show that it does not belong to the coroot lattice for the group G' . Assume the contrary. Then inside of the lattice $X_*(S_{sc})^\theta$ we have the equation $\alpha^\vee = \sum n_i \beta_i^\vee$ for some integers n_i and some roots $\beta_i' \in R'$. We choose for each β_i' a lift $\beta_i \in \dot{R}'$ and apply [Lemma A.4](#), thereby obtaining

$$\alpha^\vee = \sum n_i \beta_i^\vee + \sum n_i (\beta_i^\vee + \theta\beta_i^\vee),$$

where we have subdivided the set of $\{\beta_i\}$ into the cases corresponding to [\(A-2\)](#). This equation holds inside the coroot lattice of H_{sc} . Since R is a simply laced root system, the bijection $R \rightarrow R^\vee, \beta \mapsto \beta^\vee$ extends to a \mathbb{Z} -linear bijection from the root lattice to the coroot lattice. This tells us that we have the equation

$$\alpha = \sum n_i \beta_i + \sum n_i (\beta_i + \theta\beta_i)$$

in the root lattice of H_{sc} , i.e., in $X^*(S)$. However, the right-hand side is a character of S which kills the element $s \in S$. This would imply that $\alpha \in \dot{R}'$, which would then imply that θ acts trivially on the root space \mathfrak{h}_α . This is, however, false, because for $X = \text{Ad}(g)X_{\tilde{\gamma}} \in \mathfrak{h}_\alpha$ we have

$$\theta(X) = \text{Ad}(g) \text{Ad}(g^{-1}\theta(g))\theta(X_{\tilde{\gamma}}) = \text{Ad}(g) \text{Ad} \eta_{\tilde{\gamma}} \begin{bmatrix} & -i \\ -i & \end{bmatrix} (-X_{\tilde{\gamma}^{-1}}) = -X.$$

The proof of [Lemma A.3](#) is now complete.

Acknowledgements

I am grateful to Manjul Bhargava, Dick Gross, and Tasho Kaletha for many interesting conversations. I would like to thank Tasho again for writing the appendix to this paper. Finally, I thank the anonymous referee for helpful comments.

References

- [Bhargava and Gross 2013] M. Bhargava and B. H. Gross, “The average size of the 2-Selmer group of Jacobians of hyperelliptic curves having a rational Weierstrass point”, pp. 23–91 in *Automorphic representations and L-functions*, edited by D. Prasad et al., Tata Inst. Fundam. Res. Stud. Math. **22**, Tata Inst. Fund. Res., Mumbai, 2013. [MR 3156850](#) [Zbl 1303.11072](#)
- [Bhargava and Gross 2014] M. Bhargava and B. H. Gross, “Arithmetic invariant theory”, pp. 33–54 in *Symmetry: representation theory and its applications*, edited by R. Howe et al., Progr. Math. **257**, Birkhäuser/Springer, New York, 2014. [MR 3363006](#) [Zbl 06436604](#)
- [Birch and Swinnerton-Dyer 1963] B. J. Birch and H. P. F. Swinnerton-Dyer, “Notes on elliptic curves, I”, *J. Reine Angew. Math.* **212** (1963), 7–25. [MR 0146143](#) [Zbl 0118.27601](#)
- [Birkenhake and Lange 2004] C. Birkenhake and H. Lange, *Complex abelian varieties*, 2nd ed., Grundlehren der Mathematischen Wissenschaften [Fundamental Principles of Mathematical Sciences] **302**, Springer, Berlin, 2004. [MR 2062673](#) [Zbl 1056.14063](#)
- [Bourbaki 2002] N. Bourbaki, *Lie groups and Lie algebras, Chapters 4–6*, Springer, Berlin, 2002. [MR 1890629](#) [Zbl 0983.17001](#)
- [Dolgachev 2012] I. V. Dolgachev, *Classical algebraic geometry, a modern view*, Cambridge University Press, 2012. [MR 2964027](#) [Zbl 1252.14001](#)
- [Dolgachev and Ortland 1988] I. Dolgachev and D. Ortland, *Point sets in projective spaces and theta functions*, Astérisque **165**, Société Mathématique de France, Paris, 1988. [MR 1007155](#) [Zbl 0685.14029](#)
- [de Graaf 2011] W. A. de Graaf, “Computing representatives of nilpotent orbits of θ -groups”, *J. Symbolic Comput.* **46**:4 (2011), 438–458. [MR 2765379](#) [Zbl 1222.17002](#)
- [Griffiths and Harris 1994] P. Griffiths and J. Harris, *Principles of algebraic geometry*, John Wiley & Sons, New York, 1994. [MR 1288523](#) [Zbl 0836.14001](#)
- [Gross and Harris 1981] B. H. Gross and J. Harris, “Real algebraic curves”, *Ann. Sci. École Norm. Sup.* (4) **14**:2 (1981), 157–182. [MR 631748](#) [Zbl 0533.14011](#)
- [Gross and Harris 2004] B. H. Gross and J. Harris, “On some geometric constructions related to theta characteristics”, pp. 279–311 in *Contributions to automorphic forms, geometry, and number theory*, edited by H. Hida et al., Johns Hopkins Univ. Press, Baltimore, MD, 2004. [MR 2058611](#) [Zbl 1072.14032](#)
- [Kostant 2012] B. Kostant, “The cascade of orthogonal roots and the coadjoint structure of the nilradical of a Borel subgroup of a semisimple Lie group”, *Mosc. Math. J.* **12**:3 (2012), 605–620. [MR 3024825](#) [Zbl 1260.14058](#)
- [Kottwitz and Shelstad 1999] R. E. Kottwitz and D. Shelstad, *Foundations of twisted endoscopy*, Astérisque **255**, Société Mathématique de France, Paris, 1999. [MR 1687096](#) [Zbl 0958.22013](#)
- [Looijenga 1993] E. Looijenga, “Cohomology of \mathcal{M}_3 and \mathcal{M}_3^1 ”, pp. 205–228 in *Mapping class groups and moduli spaces of Riemann surfaces* (Göttingen, 1991/Seattle, WA, 1991), edited by C.-F. Bödigheimer and R. M. Hain, Contemp. Math. **150**, Amer. Math. Soc., Providence, RI, 1993. [MR 1234266](#) [Zbl 0814.14029](#)
- [Lurie 2001] J. Lurie, “On simply laced Lie algebras and their minuscule representations”, *Comment. Math. Helv.* **76**:3 (2001), 515–575. [MR 1854697](#) [Zbl 1017.17011](#)
- [Panyushev 2005] D. I. Panyushev, “On invariant theory of θ -groups”, *J. Algebra* **283**:2 (2005), 655–670. [MR 2111215](#) [Zbl 1071.17005](#)
- [Poonen and Rains 2012] B. Poonen and E. Rains, “Random maximal isotropic subspaces and Selmer groups”, *J. Amer. Math. Soc.* **25**:1 (2012), 245–269. [MR 2833483](#) [Zbl 1294.11097](#)

- [Reeder 2010] M. Reeder, “Torsion automorphisms of simple Lie algebras”, *Enseign. Math.* (2) **56**:1-2 (2010), 3–47. [MR 2674853](#) [Zbl 1223.17020](#)
- [Reeder 2011] M. Reeder, “Elliptic centralizers in Weyl groups and their coinvariant representations”, *Represent. Theory* **15** (2011), 63–111. [MR 2765477](#) [Zbl 1251.20042](#)
- [Reeder et al. 2012] M. Reeder, P. Levy, J.-K. Yu, and B. H. Gross, “Gradings of positive rank on simple Lie algebras”, *Transform. Groups* **17**:4 (2012), 1123–1190. [MR 3000483](#) [Zbl 1310.17017](#)
- [Richardson 1982a] R. W. Richardson, “Conjugacy classes of involutions in Coxeter groups”, *Bull. Austral. Math. Soc.* **26**:1 (1982), 1–15. [MR 679916](#) [Zbl 0531.20017](#)
- [Richardson 1982b] R. W. Richardson, “Orbits, invariants, and representations associated to involutions of reductive groups”, *Invent. Math.* **66**:2 (1982), 287–312. [MR 656625](#) [Zbl 0508.20021](#)
- [Steinberg 1968] R. Steinberg, *Endomorphisms of linear algebraic groups*, Memoirs of the American Mathematical Society **80**, Amer. Math. Soc., Providence, RI, 1968. [MR 0230728](#) [Zbl 0164.02902](#)
- [Thorne 2013] J. A. Thorne, “Vinberg’s representations and arithmetic invariant theory”, *Algebra Number Theory* **7**:9 (2013), 2331–2368. [MR 3152016](#) [Zbl 1321.11045](#)
- [Tits 1966] J. Tits, “Classification of algebraic semisimple groups”, pp. 33–62 in *Algebraic Groups and Discontinuous Subgroups* (Boulder, Colo., 1965), edited by A. Borel and G. D. Mostow, Amer. Math. Soc., Providence, RI, 1966. [MR 0224710](#) [Zbl 0238.20052](#)
- [Wang 2013] X. Wang, *Pencils of quadrics and Jacobians of hyperelliptic curves*, Ph.D. thesis, Harvard University, 2013, available at <http://nrs.harvard.edu/urn-3:HUL.InstRepos:11156784>.

Communicated by Jean-Louis Colliot-Thélène

Received 2015-04-02

Revised 2016-04-29

Accepted 2016-07-18

thorne@dpmmms.cam.ac.uk

*Department of Pure Mathematics and Mathematical Statistics,
University of Cambridge, Wilberforce Road,
Cambridge CB3 0WB, United Kingdom*

kaletha@umich.edu

*Department of Mathematics, University of Michigan,
530 Church Street, Ann Arbor, MI 48109-1043, United States*

Furstenberg sets and Furstenberg schemes over finite fields

Jordan S. Ellenberg and Daniel Erman

We give a lower bound for the size of a subset of \mathbb{F}_q^n containing a rich k -plane in every direction, a k -plane Furstenberg set. The chief novelty of our method is that we use arguments on nonreduced subschemes and flat families to derive combinatorial facts about incidences between points and k -planes in space.

1. Introduction

A central question in harmonic analysis is the *Keakeya conjecture*, which holds that a subset S of \mathbb{R}^n containing a unit line segment in every direction has Hausdorff dimension n . Many refinements and generalizations of the Keakeya conjecture have appeared over the years. For instance, one may loosen the condition on S , asking only that there be a line segment in every direction whose intersection with S is large in the sense of Hausdorff dimension.

Question 1.1 (Furstenberg set problem). Let S be a compact subset of \mathbb{R}^n such that, for every line $\ell \subset \mathbb{R}^n$, there is a line parallel to ℓ whose intersection with S has Hausdorff dimension at least c . What can be said about the Hausdorff dimension of S ?

This problem was introduced by Wolff [1999, Remark 1.5], based on ideas of Furstenberg. Wolff showed that $\dim S > \max(c + \frac{1}{2}, cn)$, and gave examples of S with $\dim S = \frac{3}{2}c + \frac{1}{2}$.

More generally, we can ask the same question about k -planes:

Question 1.2 (k -plane Furstenberg set problem). Let S be a compact subset of \mathbb{R}^n such that, for every k -plane $W \subset \mathbb{R}^n$, there is a k -plane parallel to W whose intersection with S has Hausdorff dimension at least c . What can be said about the Hausdorff dimension of S ?

Ellenberg is supported by NSF Grant DMS-1402620 and a Guggenheim Fellowship, and Erman was supported by NSF Grant DMS-1302057.

MSC2010: primary 14G15; secondary 13P10, 42B25, 51E20.

Keywords: Keakeya sets, Furstenberg sets.

In this paper, we consider discrete and finite-field analogues of the k -plane Furstenberg set problem.

Question 1.3 (k -plane Furstenberg set problem over finite fields). Let \mathbb{F}_q be a finite field, and let S be a subset of \mathbb{F}_q^n such that, for every k -plane $W \subset \mathbb{F}_q^n$, there is a k -plane parallel to W whose intersection with S has cardinality at least q^c . What can be said about $|S|$?

We begin by recalling some known results about [Question 1.3](#) from the case $k = 1$. We write $|S| \gtrsim f(q, n, k, c)$ to mean that $|S| > Cf(q, n, k, c)$ for a constant C which may depend on n, k but which is independent of q .

The method of Dvir’s proof of the finite field Kakeya conjecture [[2009](#), Theorem 1.5] shows immediately that

$$|S| \gtrsim q^{cn}, \tag{1}$$

and a lower bound

$$|S| \gtrsim q^{c+(n-1)/2} \tag{2}$$

follows immediately by elementary combinatorial considerations, as we now explain. The number of triples (L, P_1, P_2) where L is one of the hypothesized lines and P_1 and P_2 are points of S contained in L is at least $q^{(n-1)+2c}$ since at least q^{n-1} lines are needed to cover all directions and each line contains at least q^c points. But the map sending (L, P_1, P_2) to (P_1, P_2) is an injection into S^2 ; we conclude that $|S| \gtrsim q^{c+(n-1)/2}$, as claimed.

In the other direction, Ruixiang Zhang [[2015](#), Theorem 2.8] has produced examples showing that it is possible to have

$$|S| \lesssim q^{(n+1)(c/2)+(n-1)/2}.$$

He conjectures that this upper bound is in fact sharp when q is *prime*. It is not sharp in general: an example of Wolff [[1999](#), Remark 2.1] shows that when $q = p^2$ and $c = \frac{1}{2}$ it is possible to have

$$|S| \lesssim q^{n/2}.$$

In particular, when $q = p^2$ both lower bounds (1) and (2) are sharp at the critical exponent $c = \frac{1}{2}$.

Much less is known about higher k . In [[Ellenberg et al. 2010](#), Conjecture 4.13], the first author, with Oberlin and Tao, proposed a k -plane maximal operator estimate in finite fields. When $k = 1$, we prove the estimate [[Ellenberg et al. 2010](#), Theorem 2.1], which bounds the Kakeya maximal operator and generalizes Dvir’s theorem. For general k it remains a conjecture. Its truth would imply that, for S satisfying the hypothesis in [Question 1.3](#),

$$|S| \gtrsim q^{cn/k}.$$

The main goal of the present paper is to show that this proposed lower bound for the k -plane Furstenberg problem is in fact correct.

Proposition 1.4. *Let S be a subset of \mathbb{F}_q^n . Let $c \in [0, k]$. Suppose that, for each k -plane $W \subset \mathbb{F}_q^n$, there is a k -plane V parallel to W with $|S \cap V| \geq q^c$. Then*

$$|S| > Cq^{cn/k}$$

for some constant C depending only on n and k .

The condition $c \in [0, k]$ in the statement is superfluous, since a k -plane has at most q^k points in all. We include it in order to emphasize the analogy with [Theorem 1.5](#). See [Remark 1.6](#) for more discussion of this point.

The constant C is independent of c ; this fact is a consequence of the geometric nature of our proof, which in the end is not about subsets of \mathbb{F}_q^n but about subschemes of affine space over an arbitrary base field, as in [Theorem 1.7](#).

In order to prove [Proposition 1.4](#), we introduce an algebraic technique which is familiar in algebraic geometry but novel in the present context; that of *degeneration*.

A subset of \mathbb{F}_q^n can be thought of as a reduced 0-dimensional subscheme of the affine space $\mathbb{A}^n/\mathbb{F}_q$. Once this outlook has been adopted, it is natural to pose the Furstenberg set problem in a more general context, addressing all 0-dimensional subschemes, not only the reduced ones.

Denote by R the polynomial ring $\mathbb{F}_q[x_1, \dots, x_n]$. A 0-dimensional subscheme S of \mathbb{A}^n is defined by an ideal $I \subset R$ such that R/I is a finite-dimensional vector space over \mathbb{F}_q . The scheme S is the affine scheme $\text{Spec } R/I$. When R/I is isomorphic to a direct sum of fields, S is reduced and can be thought of as a set of points, and I is the ideal of polynomials which vanish on the set of points.

By contrast, a typical nonreduced example is the “fat point” S defined by $I = (x_1, \dots, x_n)^d$. We think of S as a copy of the origin which has been “thickened” infinitesimally; to evaluate a function at S is to specify its values and all its partial derivatives of degree at most $d - 1$. In particular, to say a polynomial f vanishes at S is to say its partials of degree at most $d - 1$ all vanish at the origin 0, which is exactly to say it belongs to the ideal I .

We denote $\dim_{\mathbb{F}_q} R/I$ by $|S|$; when S is reduced (i.e., a set of points) then $|S|$ is the cardinality of the set of geometric points of S , just as the notation suggests. When S is the fat point defined by $I = (x_1, \dots, x_n)^{d+1}$ then S/I has an \mathbb{F}_q basis consisting of all monomials in x_1, \dots, x_n of degree at most d . It follows that $|S| = \binom{n+d}{d}$.

Our main theorem is that the lower bound on the size of a Furstenberg set asserted in [Proposition 1.4](#) applies word for word to Furstenberg schemes.

Theorem 1.5. *Let S be a 0-dimensional subscheme of $\mathbb{A}^n/\mathbb{F}_q$. Let $c \in [0, k]$. Suppose that, for each k -plane $W \subset \mathbb{A}^n$ defined over \mathbb{F}_q , there is a k -plane V*

parallel to W with $|S \cap V| \geq q^c$. Then

$$|S| > Cq^{cn/k}$$

for some constant C depending only on n and k .

Remark 1.6. The condition $c \in [0, k]$ is superfluous in [Proposition 1.4](#), but not in [Theorem 1.5](#). The subscheme of \mathbb{A}^2 cut out by the ideal (x, y^N) , for instance, intersects the line $x = 0$ in degree N and every other line in degree 1. Note that N can be much larger than q ; once we leave the world of reduced schemes, there is no a priori upper bound for the intersection of S with a line! In particular, the union of $q + 1$ rotations of this scheme has $|S|$ on order Nq and has $|S \cap V| \geq N$ for every \mathbb{F}_q -rational line $V \in \mathbb{A}^2$. If $N = q^c$ and we allowed $c > 1$, we would have $|S| \sim q^{c+1} \leq q^{2c}$, violating the theorem statement.

Why is [Theorem 1.5](#) easier to prove than its special case [Proposition 1.4](#)? The answer involves certain parameter spaces for Furstenberg set problems (constructed in [Section 4](#)) that allow us to vary the collection of points S . The degenerate 0-dimensional schemes form the boundary of this parameter space, and we can bound various functions for all S by bounding them for these degenerate schemes. Then, as happens very often in algebraic geometry, after overcoming an initial resistance to degenerating to a nonsmooth situation, we discover that the degenerate situation is actually easier than the original one.

Because our arguments are geometric in nature, they apply over a general field k , not only finite fields. The k -planes through the origin in \mathbb{A}^n — which we may think of as the set of possible directions — is parametrized by the Grassmannian $\text{Gr}(k, n)$. Given m, k , and S , we let $\Sigma_{m,k}^S \subseteq \text{Gr}(k, n)(k)$ denote the set of directions ω such that there is some k -plane V in direction ω with $|S \cap V| \geq m$. We call such a direction *m-rich*. Our key technical idea is to observe that the set of *m-rich* k -plane directions is more naturally thought of as the set of k -points on a scheme $X_{m,k}^S$, cut out by polynomial equations on the Grassmannian, and to closely study the properties of those defining equations. We define $X_{m,k}^S$ precisely in [Section 4](#). This point of view leads to the following more flexible theorem, from which [Theorem 1.5](#) will follow without much trouble.

Theorem 1.7. *Let k be an arbitrary field and let S be a 0-dimensional subscheme of \mathbb{A}^n/k . Let $X_{m,k}^S \subseteq \text{Gr}(k, n)$ be the moduli space of directions of *m-rich* k -planes for S . Then either*

- (1) $X_{m,k}^S = \text{Gr}(k, n)$ (that is, every k -plane direction is *m-rich*) and $|S|$ is at least $C_1 m^{n/k}$, for a constant C_1 depending only on n and k ; or
- (2) $\Sigma_{2m,k}^S$ is contained in a hypersurface $Z \subseteq \text{Gr}(k, n)$ of degree at most $C_2 |S|/m$, for a constant C_2 depending only on n and k .

The connection between [Theorem 1.7](#) and [Theorem 1.5](#) involves a descending induction argument to reduce to the case $k = n - 1$, combined with a simple observation about \mathbb{F}_q -points. Working over \mathbb{F}_q , let $k = n - 1$ and $m = q^c$ and assume that $|S| = o(q^{cn/(n-1)})$. Then [Theorem 1.7\(2\)](#) implies that $X_{m,n-1}^S$ lies in a hypersurface of degree $o(q)$. However, this would contradict the hypotheses of [Theorem 1.5](#), as no hypersurface of degree less than q can contain every \mathbb{F}_q -point of $\text{Gr}(n - 1, n)$.

Remark 1.8. Our results do not rely on Dvir’s theorem [[2009](#), Theorem 1.5], and hence the special case of [Theorem 1.5](#) when $k = c = 1$ yields what seems to us an independent proof of Dvir’s theorem on Kakeya sets in finite fields.

Remark 1.9. The bounds in [Theorem 1.5](#) are sharp for every c ; take S to be the fat point of degree q^c supported at the origin, so that the intersection of S with any k -plane is on order q^{ck} and $|S|$ is on order q^{cn} . The bounds in [Proposition 1.4](#), however, are *not* sharp, or at least are not sharp over the whole range $c \in [0, k]$. Already when $k = 1$ we see that the bound $|S| \gtrsim q^{cn}$ fails to be sharp only when $c < \frac{1}{2}$ (and when q is prime, it fails to be sharp for $c < 1$, by a result of Zhang [[2015](#), Theorem 1.4].) The results of the present paper suggest that purely algebraic arguments apply to 0-dimensional schemes over arbitrary fields and are effective at controlling k -planes which are very rich in incidences, while more combinatorial arguments, which apply only to point sets, may be stronger tools for bounding incidences arising from k -planes which are not so rich in points.

Remark 1.10. The scheme-theoretic methods of this paper may seem very distant from anything that could be of use in Euclidean problems. But there is an interesting similarity between the degeneration method used here and the method used by Bennett, Carbery, and Tao in their work on the multilinear Kakeya conjecture [[Bennett et al. 2006](#)]. Their work required bounding an ℓ^p norm on a sum of characteristic functions of thin tubes in different directions; one idea in their paper involves sliding all these tubes towards 0 until they all intersect at the origin, and showing that the quantities they are trying to bound only go up under that process. (See especially [[Bennett et al. 2006](#), Question 1.14].) An argument of this kind can also be found in [[Bennett et al. 2009](#)]. Our method is in some sense very similar; the main degeneration we consider is a dilation, where all points in S move to 0 and all lines in direction ω slide to the line through 0 in direction ω . Our hope is that the large existing body of work in this area of algebraic geometry may provide more ideas for carrying out “degeneration” arguments in the Euclidean setting.

This paper is organized as follows. In [Section 2](#) we outline some notation that we will use throughout the paper. In [Section 3](#) we give a detailed sketch of the proof of [Theorem 1.5](#). [Section 4](#) contains much of the technical work of the paper, as we construct the schemes $X_{m,k}^S$ and study some of their essential properties. In

[Section 5](#), we focus on the special case of when $X_{m,k}^S$ equals the entire Grassmannian, as this plays a central role in our main results. [Sections 6 and 7](#) then contain the proofs of [Theorems 1.5 and 1.7](#). In [Section 8](#) we discuss an approach to the k -plane restriction conjecture of [\[Ellenberg et al. 2010\]](#), and [Section 9](#) concludes with a few examples.

2. Notation and background

In this section we gather some of the notation that we will use throughout. For reference, we also gather some of the notation from the introduction. Throughout, k will denote an arbitrary field and \mathbb{F}_q will denote a finite field of cardinality q . If Z is a scheme over k and k' is a field over k , then we write $Z(k')$ for the k' -valued points of Z .

We use S to denote a 0-dimensional subscheme of \mathbb{A}^n/k , and I_S to denote its defining ideal, so that $S = \text{Spec } k[x_1, \dots, x_n]/I_S$. We set $|S| := \dim_k k[x_1, \dots, x_n]/I_S$. If S is a 0-dimensional subscheme of \mathbb{A}^n/k as above, and V is a linear space cut out by linear forms ℓ_1, \dots, ℓ_s , we mean by $S \cap V$ the scheme-theoretic intersection $\text{Spec } k[x_1, \dots, x_n]/(I_S + (\ell_1, \dots, \ell_s))$. We say that V is *m -rich for S* if $|S \cap V| \geq m$.

We also review a few concepts about ideals. Let R be a graded k -algebra of finite type and let $J \subseteq R$ be an ideal. The radical of J , denoted \sqrt{J} , is the ideal

$$\sqrt{J} = \{f \in R \mid f^n \in J \text{ for some } n \geq 0\}.$$

The ideal \sqrt{J} contains all functions that vanish on the subset $V(J) \subseteq Z$. The m -th power of J , denoted J^m , is the ideal generated by m -fold products of functions from J :

$$J^m = \langle f = f_1 f_2 \cdots f_m \mid f_i \in J \rangle \subseteq R.$$

If J is prime, then we can define the m -th symbolic power of J , denoted $J^{(m)}$, to be the J -primary component of J^m . A similar definition is used for ideals J which are not prime.

However, there is a simpler definition of symbolic powers in the cases arising in this paper. Namely, if R is the homogeneous coordinate ring of a smooth, projective subvariety $Z \subseteq \mathbb{P}^r$, then we have the following geometric characterization of symbolic powers due to Zariski and Nagata [\[Eisenbud 1995, §3.9\]](#). Assume that $I \subseteq R$ is radical. Then the symbolic power $I^{(m)}$ equals the ideal of functions that vanish with multiplicity m along the locus $V(I) \subseteq Z$. In particular, if we write \mathfrak{m}_x for the homogeneous prime ideal in R corresponding to a point $x \in V(I)$, then

$$I^{(m)} = \bigcap_{x \in V(I)} \mathfrak{m}_x^m.$$

In general, we have $I^m \subseteq I^{(m)}$, but not equality.

3. Sketch of the proof

We begin with an overall sketch of the proof of [Theorem 1.5](#). The idea is as follows. Let S be a 0-dimensional subscheme of \mathbb{A}^n . Then we can degenerate S by *dilation* to a subscheme S_0 of \mathbb{A}^n which is supported at the origin, and which has $|S_0| = |S|$. We may think of S_0 as the limit of tS as t goes to 0. If V is a k -plane with $|S \cap V| \geq q^c$, then $|S_0 \cap V_0| \geq q^c$, where V_0 is the k -plane through the origin parallel to V . In particular, the Furstenberg condition on S implies that $|S_0 \cap V_0| \geq q^c$ for every \mathbb{F}_q -rational k -plane through the origin in \mathbb{A}^n . The supremum over a parallel family of k -planes has disappeared from the condition, which allows for an easy induction argument reducing us to the case $k = n - 1$. Namely: given that [Theorem 1.5](#) holds for $k = n - 1$, let W_0 be a $(k+1)$ -plane through the origin in \mathbb{A}^n . Every k -plane V_0 through the origin in \mathbb{A}^n satisfies $|S_0 \cap V_0| \geq q^c$, so [Theorem 1.5](#) tells us that $|S_0 \cap W_0| \geq q^{c(k+1)/k}$ for every choice of W_0 . Iterating this argument $n - k$ times gives us the desired bound $|S_0| \geq q^{cn/k}$.

This leaves the proof of [Theorem 1.5](#) in the hyperplane case. We prove this proposition by considering a geometric version of the Radon transform. The Radon transform may be thought of as a function f_S on the Grassmannian $\text{Gr}(n - 1, n) \cong \mathbb{P}^{n-1}$, defined by

$$f_S(V_0) = |S_0 \cap V_0|.$$

(Usually the Radon transform is thought of as a function on all hyperplanes, not only those through the origin; in this case, since S_0 is supported at the origin, the Radon transform vanishes on those hyperplanes not passing through the origin.)

Unfortunately, the notion of real-valued function doesn't transfer to the scheme-theoretic setting very neatly; what works better is the notion of level set. Naively, we might define

$$X_{m,n-1}^{S_0} = \{V_0 \in \text{Gr}(n - 1, n) \mid |V_0 \cap S_0| \geq m\}$$

as the set of m -rich hyperplanes through the origin.

It turns out, however, that to make the notion of Radon transform behave well under degeneration, we need to think of the level set $X_{m,n-1}^{S_0}$ not as a subset of the k -points of $\text{Gr}(n - 1, n)$, but as a *subscheme* of $\text{Gr}(n - 1, n)$. In fact, for easy formal reasons, it is a closed subscheme. This viewpoint has the further advantage that we can argue geometrically, without any reference to the field over which we are working. We explain the definition of $X_{m,n-1}^{S_0}$ and its behavior under degeneration of S in [Section 4](#), which is where most of the technical algebraic geometry is to be found.

We show in [Proposition 5.1](#) that, for m sufficiently large relative to $N^{(n-1)/n}$, the level scheme $X_{m,n-1}^{S_0}$ is not the whole of $\text{Gr}(n - 1, n)$. This argument involves a further degeneration, a *Gröbner degeneration* from S_0 to a member of a yet more

restricted class of schemes called Borel-invariant subschemes. Thus, $X_{m,n-1}^{S_0}$, being Zariski closed, is contained in a proper hypersurface. We bound the degree of this hypersurface in part (2) of [Theorem 1.7](#) (by means of explicit defining equations), and this provides the final piece of the proof of [Theorem 1.5](#).

4. The schemes $X_{m,k}^S$

Beginning in this section, we work over an arbitrary field k and omit the field k from most of the notation, for example writing \mathbb{A}^n in place of \mathbb{A}^n/k . It may be useful for the reader to imagine that $k = \mathbb{F}_q$.

Initially, we let S be a collection of points (a reduced 0-dimensional scheme) in \mathbb{A}^n . Let S_0 be the degeneration of S by the *dilation* action. This can be defined concretely as follows. Let $I \subset k[x_1, \dots, x_n]$ be the ideal of polynomials vanishing at S . If t is an element of k^* , then the ideal of functions vanishing at the dilation $S_t := tS$ is precisely

$$I_t = \{f(t^{-1}x_1, \dots, t^{-1}x_n) \mid f \in I\}.$$

We then ask what happens as “ t goes to 0”. Of course, this doesn’t literally make sense since k is not necessarily \mathbb{R} or \mathbb{C} , but may be a finite field or something even more exotic. Nonetheless, if one thinks of t as getting “smaller”, then $f(t^{-1}x_1, \dots, t^{-1}x_n)$ will be “dominated” by its highest-degree term f_d , a homogeneous polynomial. So the dilation I_0 is defined to be the homogeneous ideal generated by the highest-degree terms of polynomials in I , and $S_0 = \text{Spec } k[x_1, \dots, x_n]/I_0$ is the subscheme of \mathbb{A}^n cut out by the vanishing of the polynomials of I_0 . It’s clear that $|S_t| = |S|$ for all $t \in k^*$; in fact, S_t is isomorphic to S . It turns out that S_0 , while not typically isomorphic to S , does satisfy $|S_0| = |S|$, as a consequence of the Hilbert polynomial being constant in flat families.

Now let $\Sigma_{m,k}^S \subseteq \text{Gr}(k, n)(k)$ denote the set of directions of all k -planes that are m -rich for S . As observed in the first paragraph of [Section 3](#), if S_0 is the degeneration of S by the dilation action, then $\Sigma_{m,k}^{S_0}$ will contain $\Sigma_{m,k}^S$. This follows from the following standard lemma.

Lemma 4.1. *Let V be a k -plane in \mathbb{A}^n such that $|S \cap V| \geq m$. Let V_0 be the k -plane through the origin parallel to V . Then $|S_0 \cap V_0| \geq m$.*

Geometrically, we think of the rationale for [Lemma 4.1](#) as follows: if V is a k -plane with $|S \cap V| \geq m$, then for every t , the dilation tS is contained in the plane tV . As t goes to 0, tV converges to the k -plane V_0 parallel to V and through the origin, and we find that $|S_0 \cap V_0| \geq m$.

Proof. We consider $S_t \cap V_t$ as a family of 0-dimensional schemes over $\mathbb{A}^1 = \text{Spec}(k[t])$. When $t \neq 0$, the degree of the fiber is constant and equals $|S \cap V|$. By

semicontinuity (see [Hartshorne 1977, Theorem III.12.8] or Proposition 4.8 below) we have $|S_0 \cap V_0| \geq |S \cap V|$. \square

We henceforth focus on the case on the case where S is a nonreduced 0-dimensional scheme supported at the origin and defined by a homogeneous ideal $I_S \subseteq \mathbf{k}[x_1, \dots, x_n]$. We let $N := |S| = \dim_{\mathbf{k}} \mathbf{k}[x_1, \dots, x_n]/I_S$.

Constructing the schemes $X_{m,k}^S$. In this section, and henceforth, we adopt a more geometric point of view, replacing the set $\Sigma_{m,k}^S$ with a moduli scheme $X_{m,k}^S$ of m -rich k -plane directions, satisfying

$$X_{m,k}^S(\mathbf{k}) = \Sigma_{m,k}^S.$$

The key result can be summarized as follows.

Proposition 4.2. *Fix integers m and k and fix a 0-dimensional scheme S supported at the origin and defined by a homogeneous ideal I . There exists a closed subscheme $X_{m,k}^S \subseteq \text{Gr}(k, n)$ such that the set $X_{m,k}^S(\mathbf{k})$ of \mathbf{k} -rational points on $X_{m,k}^S$ is naturally in bijection with set $\Sigma_{m,k}^S$ of m -rich k -plane directions for S .*

If we instead fix integers m, k and N , and let S vary among all such 0-dimensional schemes of degree N , then the various $X_{m,k}^S$ can be realized as the fibers of a map of schemes $Y_{m,k} \rightarrow H^N$, where H^N stands for the \mathbb{G}_m -equivariant Hilbert scheme $\text{Hilb}^N(\mathbb{A}^n)$.

The proof, which is a standard construction in algebraic geometry, will use some notions that may be unfamiliar to readers in other areas. For background, see [Bruns and Herzog 1993, §4] about Hilbert functions and Hilbert polynomials and [Griffiths and Harris 1978, Chapter 1.5] or [Kleiman and Laksov 1972] about Grassmannians.

Proof of Proposition 4.2. Let H^N stand for the \mathbb{G}_m -equivariant Hilbert scheme $\text{Hilb}^N(\mathbb{A}^n)$. This scheme parametrizes homogeneous ideals $J \subseteq \mathbf{k}[x_1, \dots, x_n]$ such that $\dim_{\mathbf{k}} \mathbf{k}[x_1, \dots, x_n]/J = N$; equivalently, it parametrizes zero-dimensional subschemes of \mathbb{A}^n that are equivariant with respect to the \mathbb{G}_m dilation action. (Note that H^N decomposes as a union of multigraded Hilbert schemes depending on the Hilbert function of J . See [Haiman and Sturmfels 2004, Theorem 1.1] for details.)

We want to define an incidence scheme that parametrizes pairs (V, S) where V is an m -rich k -plane for S . We will write $[S] \in H^N$ for the point corresponding to S and we will similarly write $[V] \in \text{Gr}(k, n)$ for the class corresponding to a k -plane V . We define our incidence scheme as follows. Let $\mathcal{I}_H \subseteq \mathcal{O}_{H^N}[x_1, \dots, x_n]$ be the ideal sheaf for the universal family over the Hilbert scheme. We write $\mathcal{O}_U := \mathcal{O}_{H^N}[x_1, \dots, x_n]/\mathcal{I}$ for the structure sheaf of the universal family over the Hilbert scheme. The ideal sheaf \mathcal{I} defines a closed subscheme $U \subseteq H^N \times \mathbb{A}^n$ whose structure sheaf is \mathcal{O}_U .

Consider the following diagram of various projections from $H^N \times \mathbb{A}^n \times \text{Gr}(k, n)$:

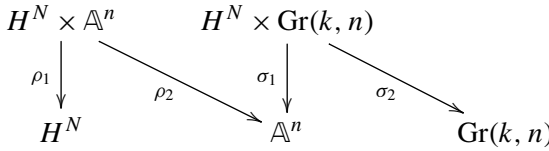

There is a tautological sequence

$$0 \rightarrow \mathcal{S} \rightarrow \mathcal{O}_{\text{Gr}(k, n)} \otimes W \rightarrow \mathcal{Q} \rightarrow 0$$

of vector bundles on $\text{Gr}(k, n)$ of rank $n - k$, n , and k , respectively, where the fiber of \mathcal{S} over the point $[V] \in \text{Gr}(k, n)$ is the $(n - k)$ -dimensional space of linear forms vanishing at V . (Readers unfamiliar with the Grassmannian might see [Griffiths and Harris 1978, Chapter 1.5]. Note that this reference uses $\text{Gr}(k, n)$ to parametrize subbundles of dimension k , whereas we follow the convention that $\text{Gr}(k, n)$ parametrizes quotient bundles of dimension k , but there is a natural way to relate these two descriptions.)

We now seek to define a map

$$\Phi : \sigma_2^* \mathcal{S} \otimes \sigma_1^* \rho_{2*} \mathcal{O}_U \rightarrow \sigma_1^* \rho_{2*} \mathcal{O}_U \tag{3}$$

of vector bundles of ranks $(n - k)N$ and N , respectively. The scheme $Y_{m, k}$ will be defined as a particular degeneracy locus of Φ . The map Φ will be built from two maps μ and ν .

Write the vector space W as $W \cong \langle x_1, \dots, x_n \rangle$. Identifying W with the space of linear forms in $\mathbf{k}[x_1, \dots, x_n]$, we get a multiplication map $W \otimes \mathcal{O}_U \rightarrow \mathcal{O}_U$ such that $x_i \otimes \mathcal{O}_U \rightarrow \mathcal{O}_U$ is given by multiplication by x_i . This passes to a map $W \otimes \rho_{2*} \mathcal{O}_U \rightarrow \rho_{2*} \mathcal{O}_U$ and in turn to a map

$$\mu : W \otimes \sigma_1^* \rho_{2*} \mathcal{O}_U \rightarrow \sigma_1^* \rho_{2*} \mathcal{O}_U.$$

To define ν we take the inclusion $\mathcal{S} \rightarrow \mathcal{O}_{\text{Gr}(k, n)} \otimes W$ from the tautological sequence and pull back by σ_2^* to obtain $\nu : \sigma_2^* \mathcal{S} \rightarrow \mathcal{O}_{\text{Gr}(k, n)} \otimes W$.

Combining μ and ν , we have

$$\sigma_2^* \mathcal{S} \otimes \sigma_1^* \rho_{2*} \mathcal{O}_U \xrightarrow{\nu \otimes \text{id}} \mathcal{O}_{\text{Gr}(k, n)} \otimes W \otimes \sigma_1^* \rho_{2*} \mathcal{O}_U \cong W \otimes \sigma_1^* \rho_{2*} \mathcal{O}_U \xrightarrow{\mu} \sigma_1^* \rho_{2*} \mathcal{O}_U,$$

and we define Φ in (3) as this composition.

We then define

$$Y_{m, k} \subseteq \text{Gr}(k, n) \times H^N$$

by the vanishing of the $(N - m + 1) \times (N - m + 1)$ minors of Φ . We claim that the points of $Y_{m, k}$ in $\text{Gr}(k, n) \times H^N$ are precisely those pairs $([V], [S])$ such that $|S \cap V| \geq m$.

To see this, we consider a fixed 0-dimensional scheme S such that $|S| = N$. We then define $X_{m,k}^S$ as follows:

Definition 4.3. Fix m, k and S as above, with $|S| = N$. We define $X_{m,k}^S$ to be the fiber of $Y_{m,k}$ over $[S] \in H^N$:

$$\begin{array}{ccc} X_{m,k}^S & \longrightarrow & Y_{m,k} \\ \downarrow & & \downarrow \\ [S] & \longrightarrow & H^N \end{array}$$

The defining equations of $X_{m,k}^S$ are given by the $(N-m+1) \times (N-m+1)$ minors of the map

$$\bar{\Phi} : \mathcal{S} \otimes \mathcal{O}_S \rightarrow \mathcal{O}_{\text{Gr}(k,n)} \otimes \mathcal{O}_S, \tag{4}$$

which is a map of vector bundles on $\text{Gr}(k, n)$. At a point $[V] \in \text{Gr}(k, n)$ the cokernel of $\bar{\Phi}$ defines the structure sheaf of $S \cap V$. Thus, $[V] \in X_{m,k}^S$ if and only if the cokernel has degree at least m , which is exactly what we wanted. In particular, as a set,

$$X_{m,k}^S(\mathbf{k}) = \{[V] \mid V \text{ is } m\text{-rich for } S\} \subseteq \text{Gr}(k, n)(\mathbf{k}) = \Sigma_{m,k}^S,$$

which is what we claimed above. □

Local structure. Fix k and S as above. We embed $\text{Gr}(k, n)$ into $\mathbb{P}^{\binom{n}{k}-1}$ via the Plücker embedding, so that $X_{m,k}^S \subseteq \mathbb{P}^{\binom{n}{k}-1}$ for all m . See [Miller and Sturmfels 2005, Chapter 14.1] or [Griffiths and Harris 1978, Chapter 1.5] for background on the Plücker embedding.

Definition 4.4. Throughout the remainder of this section, we will simplify notation by assuming that we have fixed S and k . We can then let J_m be the ideal of $(N-m+1) \times (N-m+1)$ minors of $\bar{\Phi}$ defining $X_{m,k}^S$, and we consider this ideal as an ideal of the homogeneous coordinate ring of $\text{Gr}(k, n)$. We also let $I_m := \sqrt{J_m}$ denote the radical of J_m .

Note that $J_m \subseteq I_m$ and that both ideals define the same closed subscheme, but they may not be equal. In particular, it is possible that there could be low-degree polynomials vanishing on $X_{m,k}^S$ (and hence lying in I_m) which do not come from J_m .

Lemma 4.5. *There is a constant C depending only on n and k such that the ideal J_m is generated in degree at most $C(|S| - m + 1)$. It follows that I_m contains an element of degree at most $C(|S| - m + 1)$, i.e., that X_m lies on a hypersurface of degree at most $C(|S| - m + 1)$.*

Proof. Let $N := |S|$, so that we can identify \mathcal{O}_S with \mathbf{k}^N , and have

$$\bar{\Phi} : \mathcal{S}^{\oplus N} \rightarrow \mathcal{O}_{\text{Gr}(k,n)}^{\oplus N}.$$

Let $\mathcal{O}_{\text{Gr}(k,n)}(1)$ be the Plücker line bundle on $\text{Gr}(k, n)$. There is a constant d , depending only on k and n , such that $\mathcal{S} \otimes \mathcal{O}_{\text{Gr}(k,n)}(d)$ is globally generated [Hartshorne 1977, Theorem 5.17]. If $M := \dim H^0(\text{Gr}(k, n), \mathcal{S} \otimes \mathcal{O}_{\text{Gr}(k,n)}(d))$, then we have a surjection

$$\mathcal{O}_{\text{Gr}(k,n)}(-d)^{\oplus M \cdot N} \rightarrow \mathcal{S}^{\oplus N}.$$

We now take $k \times k$ minors of Φ , with $k = |S| - m + 1$, which yields the ideal sheaf \mathcal{J}_m corresponding to the ideal J_m as the image of the map

$$\bigwedge^k \Phi = \bigwedge^k \mathcal{S}^{\oplus N} \otimes \bigwedge^k \mathcal{O}_{\text{Gr}(k,n)}^{\oplus N} \rightarrow \mathcal{O}_{\text{Gr}(k,n)}.$$

There is a natural surjection

$$\bigwedge^k \mathcal{O}_{\text{Gr}(k,n)}(-d)^{\oplus M \cdot N} \otimes \bigwedge^k (\mathcal{O}_{\text{Gr}(k,n)}^{\oplus N})^* \rightarrow \bigwedge^k \mathcal{S}^{\oplus N} \otimes \bigwedge^k (\mathcal{O}_{\text{Gr}(k,n)}^{\oplus N})^*,$$

which in turn surjects onto \mathcal{J}_m . This proves that J_m is generated in degree at most $d \cdot k$. Since $I_m \supseteq J_m$, the second statement follows immediately. \square

Lemma 4.6. *Assume that the k -plane V satisfies $|S \cap V| \geq m$. Let \mathfrak{m}_V be the maximal ideal of the point $[V] \in \text{Gr}(k, n)$. If $\ell \in \mathbb{N}$ with $\ell \leq m$, then*

$$J_\ell \subseteq \mathfrak{m}_V^{m-\ell+1}.$$

Proof. We localize the map $\bar{\Phi}$ from (4) at the point $[V]$ to get an $N(n-k) \times N$ map of free $\mathcal{O}_{\text{Gr},[V]}$ -modules. After choosing bases, we can write this as a matrix, and we denote this by $\bar{\Phi}_{[V]}$. Since V intersects S in degree m , it follows that $\bar{\Phi}_{[V]}$ has rank $N - m$. We are over a local ring, so every entry of this matrix is either a unit or lies in the maximal ideal \mathfrak{m}_V . The matrix thus has a minor of size $(N - m) \times (N - m)$ that is a unit, and so after inverting this element and performing row and column operations, we can rewrite

$$\bar{\Phi}_V = \begin{pmatrix} \text{Id}_{N-m} & 0 \\ 0 & A \end{pmatrix},$$

where A is an $(N(n-k) - (N - m)) \times m$ matrix consisting entirely of entries lying in the maximal ideal (otherwise Φ_v would have rank $N - m + 1$).

It follows that the ideal of $(N - \ell + 1) \times (N - \ell + 1)$ -minors of $\bar{\Phi}_V$ is the same as the ideal of $(m - \ell + 1) \times (m - \ell + 1)$ minors of A , and every such minor is a determinant of entries lying in \mathfrak{m}_V , and this yields the desired inclusion. \square

Corollary 4.7. *If $m \geq \ell$ then J_ℓ belongs to the symbolic power $I_m^{(m-\ell+1)}$.*

Proof. Since the Grassmannian is smooth, this follows from Lemma 4.6 and the Zariski–Nagata theorem. See also the discussion in Section 2. \square

Semicontinuity. The total parameter space $Y_{m,k}$ enables us to study properties of $X_{m,k}^S$ as S varies in H^N . We can assign $X_{m,k}^S$ a Hilbert polynomial in $\mathbb{Q}[t]$ via the Plücker embedding of the Grassmannian. We compare polynomials in $\mathbb{Q}[t]$ by saying that $f(t) > g(t)$ if this is true for all sufficiently large t .

Proposition 4.8. *Let $Z \subseteq \mathbb{P}^r \times V$ be a closed subscheme and let $\pi : Z \rightarrow V$ be the projection map. For $v \in V$ we defined Z_v as the scheme-theoretic fiber of π over v . The Hilbert polynomial of the fibers of π are upper semicontinuous in the following sense: for any fixed $f(t) \in \mathbb{Q}[t]$, the set*

$$\{v \in V \mid \text{the Hilbert polynomial of } Z_v \text{ is at least } f(t)\}$$

is a closed subset of V .

Proof. This is a standard fact but we include a short proof here for completeness.

Fix a Hilbert polynomial $p(t)$ on \mathbb{P}^r . The Gotzmann number provides a bound t_p such that, for any projective subscheme $Z' \subseteq \mathbb{P}^r$ with Hilbert polynomial $p(t)$, the Hilbert function and Hilbert polynomial of Z are equal in all degrees $\geq t_p$ (see, e.g., [Bruns and Herzog 1993, Chapter 4.3]).

We may choose a flattening stratification for π , i.e., we may write V as a finite disjoint union $V = \bigsqcup_{i=1}^s V_i$ such that the induced maps $Z \times_{\mathbb{P}^r \times V} V_i \rightarrow V_i$ are all flat. Since the Hilbert polynomial is constant in a flat family [Hartshorne 1977, Theorem III.9.9], we see that only s distinct Hilbert polynomials appear among the fibers of π . We set t_0 to be the maximum of all of the Gotzmann numbers of these Hilbert polynomials. Then for all $t \geq t_0$ and for all $[S] \in H^N$, the Hilbert polynomial of $X_{m,k}^S$ equals the Hilbert function in degrees $t \geq t_0$.

We next observe that insisting that the Hilbert function be at least a certain value is a closed condition by [Hartshorne 1977, Theorem III.12.8]. Hence, for any $f(t) \in \mathbb{Q}[t]$, the set of fibers whose Hilbert polynomial is at least $f(t)$ is an intersection of closed subschemes, and is thus a closed subscheme. \square

In the present paper, we use Proposition 4.8 only through its easy corollary below. We include Proposition 4.8 because we believe the more general formulation may be useful in later applications of the techniques introduced in this paper.

Corollary 4.9. *Let $S \subseteq \mathbb{A}^n \times \mathbb{A}^1$ be a flat family of 0-dimensional schemes over \mathbb{A}^1 . Write S_t for the fiber of S over $t \in \mathbb{A}^1$. If $X_{m,k}^{S_t} = \text{Gr}(k, n)$ for all $t \neq 0$, then $X_{m,k}^{S_0} = \text{Gr}(k, n)$.*

Proof. This amounts to the fact that $\text{Gr}(k, n)$ has maximal Hilbert polynomial among all closed subschemes of $\text{Gr}(k, n)$. If R is the homogeneous coordinate ring of $\text{Gr}(k, n)$, then any closed subscheme of $\text{Gr}(k, n)$ will be defined by a homogeneous ideal $J \subseteq R$. For every degree d , the Hilbert function of R is an upper bound for the Hilbert function of R/J , and it follows that the Hilbert polynomial of R —

or equivalently the Hilbert polynomial of $\text{Gr}(k, n)$ — is maximal as well. By [Proposition 4.8](#), it then follows that the subscheme W of \mathbb{A}^1 parametrizing those t such that $X_{m,k}^{S_t} = \text{Gr}(k, n)$ is closed. But W is dense by hypothesis, so W is all of \mathbb{A}^1 . □

5. Criteria for $X_{m,k}^S = \text{Gr}(k, n)$

One boundary case that will feature prominently in the proofs of both [Theorem 1.5](#) and [Theorem 1.7](#) is the case where $X_{m,k}^S = \text{Gr}(k, n)$ as schemes, or equivalently when all k -planes (even those defined over field extensions of \mathbf{k}) are m -rich for S . This is impossible for a reduced 0-dimensional scheme, but it can happen when S is nonreduced.

For instance, if S is the fat point defined by $(x_1, \dots, x_n)^{d+1}$ then every k -plane will be $m := \binom{d+k}{k}$ -rich. Observe that, in this case, $|S| = \binom{d+n}{n} \approx m^{n/k}$. This suggests the following result, which gives a similar lower bound on $|S|$ whenever $X_{m,k}^S = \text{Gr}(k, n)$.

Proposition 5.1. *Suppose that $X_{m,k}^S = \text{Gr}(k, n)$. Then there is a constant C depending only on n and k such that $|S| \geq Cm^{n/k}$. More precisely, if $m \geq \binom{b}{k}$ then $|S| \geq \binom{b+(n-k)}{n}$.*

Our proof of [Proposition 5.1](#) relies on a further degeneration to a Borel-fixed scheme, which we recall in [Lemma 5.2](#) below. This degeneration is most easily defined over an infinite field. Since the hypotheses and conclusions of the above proposition are unchanged under field extension, we may prove this proposition after extending the field \mathbf{k} . Over a field \mathbf{k} , we let $B \subseteq \text{GL}_n(\mathbf{k})$ be the Borel subgroup consisting of invertible upper triangular matrices, and we let B act on $\mathbf{k}[x_1, \dots, x_n]$ in the natural way. When \mathbf{k} is infinite, then we say that a subscheme $Z \subseteq \mathbb{A}^n$ is *Borel-fixed* if Z is invariant under the action of B . We refer the reader to Sections 15 and 15.9 of [\[Eisenbud 1995\]](#), respectively, for an overview of term orders and Gröbner basis techniques and for an introduction to Borel-fixed ideals.

Lemma 5.2. *Let \mathbf{k} be an infinite field and fix any 0-dimensional S supported at the origin in $\mathbb{A}_{\mathbf{k}}^n$ and defined by a homogeneous ideal I . Then there is a flat family over \mathbb{A}^1 where the fiber over $0 \in \mathbb{A}_{\mathbf{k}}^1$ is a Borel-fixed S_{in} and where every other fiber is isomorphic to S via an isomorphism that extends to a linear automorphism of $\mathbb{A}_{\mathbf{k}}^n$. Moreover, $|S_{\text{in}}| = |S|$.*

Proof. Under the assumption that \mathbf{k} is infinite, we can degenerate S to a Borel-fixed subscheme via the following recipe. Fix a term order \preceq satisfying $x_1 \preceq x_2 \preceq \dots \preceq x_n$. Choose a general element of B (this is where we use the assumption that \mathbf{k} is infinite), apply that element to I , and then take the initial ideal with respect to \preceq to obtain a new ideal I_{in} . The subscheme $S_{\text{in}} \subseteq \mathbb{A}^n$ defined by I_{in} will be Borel-fixed [\[Eisenbud 1995, Theorem 15.20\]](#).

The existence of the flat family is [Eisenbud 1995, Theorem 15.17]. The fact that $|S_{\text{in}}| = |S|$ is a consequence of flatness or of [Eisenbud 1995, Theorem 15.26]. \square

Any Borel-fixed scheme $Z \subseteq \mathbb{A}_k^n$ will be fixed under the action of the diagonal matrices, and hence it will be defined by some monomial ideal J . Moreover, the monomials not in J will be closed under the operation (called a *Borel move*) of replacing x_j with x_i for $i < j$. We thus define a *Borel-fixed set of monomials* as a collection of monomials satisfying this property, and where the complementary set of monomials is closed under multiplication by each x_i .

Lemma 5.3. (1) *Let $a, n \in \mathbb{N}$ and let Λ be a Borel-fixed set of monomials in x_1, \dots, x_n such that $|\Lambda| \geq \binom{a}{n}$. Let Λ_0 be the subset of Λ in which the power of x_1 is 0. Then*

$$|\Lambda| - |\Lambda_0| \geq \binom{a-1}{n}.$$

(2) *Let Λ be a Borel-fixed set of monomials in x_1, \dots, x_n , and let Λ_0 be the subset of Λ in which the power of x_1 is 0, and suppose $|\Lambda_0| \geq \binom{b}{n-1}$. Then*

$$|\Lambda| - |\Lambda_0| \geq \binom{b}{n}.$$

Proof. For part (1) of the lemma, we argue by induction on n . For $n = 1$ the assertion is clear: $|\Lambda| - |\Lambda_0| = |\Lambda| - 1 \geq a - 1$.

Now we suppose the lemma holds in $n - 1$ variables. We denote by Λ_k the set of monomials m in x_2, \dots, x_n such that $x_1^k m$ lies in Λ . (In particular, the definition of Λ_0 conforms with our existing notation.) We note that Λ_k is a Borel-fixed set of monomials, so we can apply our inductive hypothesis. Plainly, $\Lambda_{k+1} \subset \Lambda_k$.

Let m be a monomial in Λ_k and suppose $m x_i$ lies in Λ_k for some $i \in \{2, \dots, n\}$. Then $x_1^{k+1} m$ must also lie in Λ , since it differs from $x_1^k m x_i \in \Lambda$ by a Borel move. In particular, m lies in Λ_{k+1} . Thus, any element in $\Lambda_k \setminus \Lambda_{k+1}$ must lie on the *frontier* of Λ_k ; that is, $m x_i$ is not in Λ_k for any $i \in \{2, \dots, n\}$.

Suppose $|\Lambda_0| \geq \binom{b}{n-1}$. Let Λ_{00} be the set of monomials in Λ_0 in which the power of x_2 is 0. No two elements on the frontier of Λ_0 can differ by a power of x_2 ; it follows that the cardinality of the frontier is at most $|\Lambda_{00}|$. Combining this with the argument in the previous paragraph, we have

$$|\Lambda_1| = |\Lambda_0| - |\Lambda_0 \setminus \Lambda_1| \geq |\Lambda_0| - |\Lambda_{00}| \geq \binom{b-1}{n-1},$$

where the latter inequality follows by applying the inductive hypothesis to Λ_0 . Proceeding by induction, we have that $|\Lambda_k| \geq \binom{b-k}{n-1}$. Finally,

$$|\Lambda| - |\Lambda_0| = \sum_{k=1}^{\infty} |\Lambda_k| \geq \sum_{k=1}^{\infty} \binom{b-k}{n-1} = \binom{b}{n}. \tag{5}$$

We can now prove part (1) of the lemma. We have that $|\Lambda| \geq \binom{a}{n}$. If $|\Lambda_0| \leq \binom{a-1}{n-1}$, then

$$|\Lambda| - |\Lambda_0| \geq \binom{a}{n} - \binom{a-1}{n-1} = \binom{a-1}{n}$$

and we are done. On the other hand, if $|\Lambda_0| \geq \binom{a-1}{n-1}$, then (5) yields

$$|\Lambda| - |\Lambda_0| \geq \binom{a-1}{n}.$$

So the desired conclusion holds in either case.

Part (2) of the lemma is immediate from (5) and the paragraph preceding it. \square

Proof of Proposition 5.1. Without loss of generality, we may assume that k is an algebraically closed field.

We first prove the statement in the special case when $k = n - 1$. Suppose that $X_{m,n-1}^S = \text{Gr}(n - 1, n)$. Let S_{in} be the 0-dimensional subscheme defined by a Borel-fixed degeneration of the defining ideal of S , as in Lemma 5.2. Also by Lemma 5.2, there is a flat family over \mathbb{A}^1 where the fiber over $0 \in \mathbb{A}^1$ is S_{in} and every other fiber is isomorphic to S via an isomorphism that extends to a linear automorphism of \mathbb{A}^n . Writing S_z for the fiber over a point $z \in \mathbb{A}^1$, the locus of z such that $X_{m,n-1}^{S_z} = \text{Gr}(n - 1, n)$ contains all $t \neq 0$, by the isomorphism between S_z and S . By Corollary 4.9, that locus must contain 0 as well. In other words, $X_{m,n-1}^{S_{\text{in}}} = \text{Gr}(n - 1, n)$. Since $|S_{\text{in}}| = |S|$, it suffices to prove Proposition 5.1 in the case of a Borel-fixed subscheme.

Let S_{in} be defined by the Borel-fixed monomial ideal J and let Λ be the set of standard monomials for J , i.e., the monomials that do not lie in J . Let $\Lambda_0 \subseteq \Lambda$ be the set of standard monomials in the variables x_2, \dots, x_n . Since Λ_0 is a basis for $k[x_1, \dots, x_n]/(J, x_1)$, we have that $|\Lambda_0|$ is the degree of the intersection of S_{in} with the hyperplane $x_1 = 0$, whence $|\Lambda_0| \geq m$ by hypothesis. In fact, though we won't need this, it is not hard to see that for a Borel-fixed S_{in} , the hyperplane x_1 has the minimal intersection with S_{in} among all hyperplanes, so that the equality $X_{m,n-1}^S = \text{Gr}(n - 1, n)$ is equivalent to the inequality $|\Lambda_0| \geq m$.

Now suppose $|\Lambda_0| \geq \binom{b}{n-1}$. Then

$$|\Lambda| = |\Lambda_0| + (|\Lambda| - |\Lambda_0|) \geq \binom{b}{n-1} + \binom{b}{n} = \binom{b+1}{n},$$

where the inequality is Lemma 5.3(2). This proves Proposition 5.1 in the case $k = n - 1$.

We now consider the general case. Assume that $X_{m,k}^S = \text{Gr}(k, n)$. We fix some $(k+1)$ -plane V through the origin. By hypothesis, $|S \cap V'| \geq m$ for every k -plane V' through the origin; in particular, $|S \cap V'| \geq m$ for all V' contained in V . It follows that $X_{m,k}^{S \cap V}$ is the full Grassmannian $\text{Gr}(k, V)$. It follows from the $k = n - 1$ case of

Proposition 5.1 that $|S \cap V| \geq \binom{b+1}{k+1}$. This holds for every $(k + 1)$ -plane V through the origin. In particular, taking $m' = \binom{b+1}{k+1}$, we have that $X_{m',k+1}^S = \text{Gr}(k + 1, n)$. Iterating this argument yields the desired result. \square

6. Proof of Theorem 1.7

Proof of Theorem 1.7. For part (1) of the theorem, we assume that $X_{m,k}^S = \text{Gr}(k, n)$. We then apply **Proposition 5.1** to obtain the theorem.

We now assume that $X_{m,k}^S \neq \text{Gr}(k, n)$. Then one of the $(|S| - m + 1) \times (|S| - m + 1)$ -minors defining J_m is nonzero, and **Corollary 4.7** implies that

$$J_m \subseteq I_{2m}^{(m+1)}.$$

We next use a result of Hochster and Huneke, which generalizes a result of Ein, Lazarsfeld, and Smith [**Ein et al. 2001**], to compare symbolic powers and ordinary powers of the ideal I . If \mathfrak{m} is the irrelevant ideal for the homogeneous coordinate ring R of the Grassmannian (i.e., the unique homogeneous maximal ideal in R , which is generated by all of the linear forms in R), then [**Hochster and Huneke 2002**, Theorem 1.1(c)] implies that

$$\mathfrak{m}^{n+1} I_{2m}^{(m+1)} \subseteq I_{2m}^{\lfloor (m+1)/n \rfloor}.$$

Since J_m is generated in degree $C(|S| - m + 1)$ by **Lemma 4.5**, it follows that $\mathfrak{m}^{n+1} J_m$ is generated in degree $C(|S| - m + 1) + n + 1$. Thus I_{2m} must have some generators of degree at most $(C(|S| - m + 1) + n + 1) / \lfloor (m + 1)/n \rfloor$.

Now, if $m + 1 < n$ then we can simply choose $C_2 = n$ and part (2) is trivial. Otherwise, we can complete the proof of part (2) of the theorem by providing a constant C_2 depending only on n and k such that

$$\frac{C(|S| - m + 1) + n + 1}{\lfloor (m + 1)/n \rfloor} \leq C_2 \frac{|S|}{m},$$

noting that the expression on the left is well defined because the denominator is > 0 . This yields part (2) of the theorem. \square

7. Proof of k -plane Furstenberg bound

Proof of Theorem 1.5. We first prove the theorem in the case $k = n - 1$. We apply **Theorem 1.7**, setting $m := \frac{1}{2}q^c$. If $X_{m,n-1}^S = \text{Gr}(n - 1, n)$ then we are done by **Theorem 1.7(1)**. Otherwise, **Theorem 1.7(2)** implies that $X_{2m,n-1}^S$ lies in a hypersurface of degree at most $C_2|S|/m$. However, since $X_{2m,n-1}^S$ contains all \mathbb{F}_q -rational points of $\text{Gr}(n - 1, n)$, any such hypersurface must have degree at least $q + 1$. It follows that

$$q + 1 \leq C_2 \frac{|S|}{m}.$$

Since $m = \frac{1}{2}q^c$ we obtain

$$|S| \geq C_2(q + 1)\left(\frac{1}{2}q^c\right) \geq C_2q^{1+c}.$$

Since $c \in [0, n - 1]$, we have $1 + c \geq cn/(n - 1)$ and hence $|S| \geq C_3q^{cn/(n-1)}$ for all sufficiently large q .

We can obtain the case of general k by an iterative argument exactly parallel to the one in the proof of [Proposition 5.1](#). Suppose that S is a 0-dimensional subscheme of $\mathbb{A}^n/\mathbb{F}_q$. Without loss of generality we replace S by its dilation, so we may suppose it is supported at 0 and invariant under \mathbb{G}_m .

Assume that S has an m -rich k -plane in every direction. Since S is supported at the origin, this is to say that $|S \cap V| \geq m$ for every \mathbb{F}_q -rational k -plane through the origin. Fix some $(k + 1)$ -plane V through the origin. Then $|S \cap V'| \geq m$ for all V' contained in V . Now the proof given above of [Theorem 1.5](#) in the case $k = n - 1$ implies that $|S \cap V| \gtrsim m^{(k+1)/k}$, and this holds for every $(k + 1)$ -plane V . Iterating the argument for $k + 2, k + 3, \dots, n - 1$, we get [Theorem 1.5](#). \square

Remark 7.1. Tracing the constants with a bit more care, one obtains the following more precise lower bound, at least asymptotically in q . Fix any $\epsilon > 0$. Assume that $|S \cap V| \geq q^c/k!$ for every k -plane $V \in \text{Gr}(k, n)(\mathbb{F}_q)$. Then $|S| \geq (1 - \epsilon)q^{cn/k}/n!$ for q sufficiently large relative to ϵ .

The key point is that

$$\frac{q^c}{k!} \geq \binom{\lfloor q^{c/k} \rfloor}{k},$$

and hence by iteratively applying [Proposition 5.1](#), we get that the intersection of S with every hyperplane is at least

$$m := \binom{\lfloor q^{c/k} \rfloor}{n-1}.$$

If $X_{m,n-1}^S = \text{Gr}(n - 1, n)$ then we apply [Proposition 5.1](#) again to obtain

$$|S| \geq \binom{\lfloor q^{c/k} \rfloor}{n},$$

which grows like $q^{cn/k}/n!$ as $q \rightarrow \infty$, and hence is greater than $(1 - \epsilon)q^{cn/k}/n!$ for q sufficiently large relative to ϵ . On the other hand, for $X_{m,n-1}^S \neq \text{Gr}(n - 1, n)$, since $X_{m,n-1}^S$ contains all of the \mathbb{F}_q -points, the minimal degree of a hypersurface containing $X_{m,n-1}^S$ is at least q , and part (2) of [Theorem 1.7](#) yields

$$q \leq \frac{|S| - m + n + 2}{\lfloor (m + 1)/n \rfloor}.$$

Using the fact that

$$m = \binom{\lfloor q^{c/k} \rfloor}{n-1} \quad \text{and} \quad q^{1+c(n-1)/k} \geq q^{cn/k},$$

we get the desired bound in this case as well.

8. Relation with the k -plane restriction conjecture

One may ask how far the methods of the present paper go towards proving the k -plane restriction conjecture formulated in [Ellenberg et al. 2010], or even an extension of that conjecture to a possibly nonreduced setting as in Theorem 1.5. One immediate obstacle is that the most natural extension of the restriction conjecture is false, even when $k = 1$, as we explain below.

The restriction conjecture concerns a certain maximal operator on real-valued functions f on \mathbb{F}_q^n . Namely: we define a function $T_{n,k}$ on $\text{Gr}(k, n)$ by assigning to a k -plane direction ω the supremum, over all k -planes V parallel to ω , of $\sum_{v \in V} |f(v)|$. Then the restriction conjecture proposes a bound for this operator:

$$\|T_{n,k} f\|_n \lesssim |\text{Gr}(k, n)(\mathbb{F}_q)|^{1/n} \|f\|_{n/k}. \tag{6}$$

One way to express this conjecture more geometrically is as follows. The bound is invariant under scaling f , so we can scale f up until replacing f with a nearby integer-valued function modifies the norm negligibly. Then we define the scheme S_f to be the union, over all $x \in \mathbb{F}_q^n$, of a fat point of degree $\lfloor f(x)^{1/k} \rfloor$ supported at x .

Thus,

$$|S_f| \sim \sum_x f(x)^{n/k} = \|f\|_{n/k}^{n/k} \quad \text{and} \quad |S_f \cap V| = \sum_{v \in V} f(v),$$

so we can express $T_{n,k} f(\omega)$ as the supremum of $|S_f \cap V|$ over all planes V parallel to ω . In other words, both sides of the conjectural inequality (6) are naturally expressed in terms of the geometry of the scheme S_f and its restriction to k -planes. For a general 0-dimensional subscheme $S \subset \mathbb{A}^n$, we write $T_{n,k}(S)$ for the function on $\text{Gr}(k, n)(k)$ defined by

$$T_{n,k}(S)(\omega) = \sup_{V \parallel \omega} |S \cap V|.$$

Then we can ask whether we have an inequality

$$\|T_{n,k}(S)\|_n \lesssim |\text{Gr}(k, n)(\mathbb{F}_q)|^{1/n} |S|^{k/n} \tag{7}$$

for all 0-dimensional S ; the case $S = S_f$ is more or less equivalent to the k -plane restriction conjecture in [Ellenberg et al. 2010].

However, (7) does not hold for all S . For example, take $k = 1, n = 2$, and let S be the scheme $\text{Spec } \mathbb{F}_q[x, y]/(x, y^N)$. That is, S is a scheme of degree N ,

supported at the origin, which is contained in the line $x = 0$. Then $T_{2,1}(S)$ is N in the vertical direction and 1 in all other directions; so $\|T_{n,k}(S)\|_2 = (N^2 + q)^{1/2}$, while $|S|^{k/n} = N^{1/2}$. Then the desired inequality (7) becomes

$$(N^2 + q)^{1/2} \lesssim (q + 1)^{1/2} N^{1/2},$$

which holds only when N is small relative to q .

This is in some sense the same issue that arises in Remark 1.6, where our theorem on Furstenberg schemes requires a condition $c \in [0, k]$ which is automatically satisfied for Furstenberg sets. Something similar appears to be necessary to formulate the correct restriction conjecture for schemes. For example: if S is actually of the form S_f and is contained in the line $x = 0$, it must be reduced, from which it follows that $|S| < q$. It is an interesting question whether one can prove (7) under some geometric conditions on S . Ideally, these conditions would be lenient enough to include the schemes S_f for all real-valued functions f . One natural such question is as follows.

Question 8.1. Suppose S is a 0-dimensional subscheme of $\mathbb{A}^n/\mathbb{F}_q$ which is contained in a complete intersection of n hypersurfaces of degree Q . What upper bounds on the schemes $X_{m,k}^S$ — say, on their Hilbert functions — can we obtain in terms of $|S|$ and Q ?

Information about Question 8.1 would give insight into the case where f was an indicator function of a set S , since in that case S is contained in $\mathbb{A}^n(\mathbb{F}_q)$, which is a complete intersection of the hypersurfaces $x_i^q - x_i$ as i ranges from 1 to n .

9. Examples

Example 9.1. If $|S| \leq q^{c+\alpha}$ and $c + \alpha \leq cn/k$, then Theorem 1.7 implies that all of the q^c -rich k -planes of S must lie on a hypersurface of degree $\leq q^\alpha$. For instance, if $|S| \approx q^c$ then all of the q^c -rich k -planes of S must lie on a hypersurface of bounded degree.

Example 9.2. Let $k = 2$ and $n = 4$, and let I be the monomial ideal whose quotient ring has basis $\{1, x_1, x_2, x_3, x_4, x_4^2\}$. Note that $|S| = 6$.

The source of $\bar{\Phi}$ is a nontrivial vector bundle, and hence we cannot simply write the map as a simple matrix. We thus consider the open subset of $\text{Gr}(2, 4)$ where the Plücker coordinate p_{12} is nonzero, and here we can write any 2-plane uniquely as the vanishing set

$$\begin{cases} x_1 + \frac{p_{23}}{p_{12}}x_3 + \frac{p_{24}}{p_{12}}x_4 = 0, \\ x_2 + \frac{p_{13}}{p_{12}}x_3 + \frac{p_{14}}{p_{12}}x_4 = 0. \end{cases}$$

Over this open subset, the map $\bar{\Phi}$ can be written as a matrix

$$\Phi = \begin{matrix} & 1 & x_1 & x_2 & x_3 & x_4 & x_4^2 & 1 & x_1 & x_2 & x_3 & x_4 & x_4^2 \\ \begin{matrix} 1 \\ x_1 \\ x_2 \\ x_3 \\ x_4 \\ x_4^2 \end{matrix} & \left(\begin{array}{cccccccccccc} 0 & 0 & 0 & 0 & 0 & 0 & 0 & 0 & 0 & 0 & 0 & 0 & 0 \\ 1 & 0 & 0 & 0 & 0 & 0 & 0 & 0 & 0 & 0 & 0 & 0 & 0 \\ 0 & 0 & 0 & 0 & 0 & 0 & 1 & 0 & 0 & 0 & 0 & 0 & 0 \\ \frac{p_{23}}{p_{12}} & 0 & 0 & 0 & 0 & 0 & \frac{p_{13}}{p_{12}} & 0 & 0 & 0 & 0 & 0 & 0 \\ \frac{p_{24}}{p_{12}} & 0 & 0 & 0 & 0 & 0 & \frac{p_{14}}{p_{12}} & 0 & 0 & 0 & 0 & 0 & 0 \\ 0 & 0 & 0 & 0 & \frac{p_{24}}{p_{12}} & 0 & 0 & 0 & 0 & 0 & 0 & \frac{p_{14}}{p_{12}} & 0 \end{array} \right) \end{matrix}$$

Recall that we compute $X_{m,2}^S$ by the $(|S| - m + 1)$ -minors of $\bar{\Phi}$. If $m = 3$ then we get 4×4 -minors of $\bar{\Phi}$ which are all 0, and hence $X_{3,2}^S$ contains every point in the open subset $p_{12} \neq 0$ and thus $X_{3,2}^S = \text{Gr}(2, 4)$. If $m \geq 5$, then $X_{m,2}^S \cap \{p_{12} \neq 0\} = \emptyset$ since the rank of $\bar{\Phi}$ is 2. The case $m = 4$ is the most interesting, as then $X_{4,2}^S \cap \{p_{12} \neq 0\}$ is defined by the ideal of 3×3 minors of $\bar{\Phi}$. This yields the ideal

$$J = \left\langle \frac{p_{24}}{p_{12}}, \frac{p_{14}}{p_{12}} \right\rangle.$$

Thus, $\Sigma_{4,2}^S \cap \{p_{12} \neq 0\}$ is the set of all 2-planes of the form

$$\begin{cases} x_1 + \frac{p_{23}}{p_{12}}x_3 = 0, \\ x_2 + \frac{p_{13}}{p_{12}}x_3 = 0. \end{cases}$$

Acknowledgments

We thank Terry Tao for introducing us to the question and for noting the similarity between our method and that of [Bennett et al. 2006], and Ruixiang Zhang for helpful discussions about the Furstenberg set problem. We also thank for David Eisenbud for helpful conversations about Gröbner degenerations. We thank the referee for thoughtful suggestions on improving the clarity of the paper.

References

[Bennett et al. 2006] J. Bennett, A. Carbery, and T. Tao, “On the multilinear restriction and Kakeya conjectures”, *Acta Math.* **196**:2 (2006), 261–302. [MR 2275834](#) [Zbl 1203.42019](#)

[Bennett et al. 2009] J. Bennett, N. Bez, and A. Carbery, “Heat-flow monotonicity related to the Hausdorff–Young inequality”, *Bull. Lond. Math. Soc.* **41**:6 (2009), 971–979. [MR 2575327](#) [Zbl 1184.42001](#)

[Bruns and Herzog 1993] W. Bruns and J. Herzog, *Cohen–Macaulay rings*, Cambridge Studies in Advanced Mathematics **39**, Cambridge University Press, 1993. [MR 1251956](#) [Zbl 0788.13005](#)

- [Dvir 2009] Z. Dvir, “On the size of Kakeya sets in finite fields”, *J. Amer. Math. Soc.* **22**:4 (2009), 1093–1097. [MR 2525780](#) [Zbl 1202.52021](#)
- [Ein et al. 2001] L. Ein, R. Lazarsfeld, and K. E. Smith, “Uniform bounds and symbolic powers on smooth varieties”, *Invent. Math.* **144**:2 (2001), 241–252. [MR 1826369](#) [Zbl 1076.13501](#)
- [Eisenbud 1995] D. Eisenbud, *Commutative algebra: with a view toward algebraic geometry*, Graduate Texts in Mathematics **150**, Springer, New York, 1995. [MR 1322960](#) [Zbl 0819.13001](#)
- [Ellenberg et al. 2010] J. S. Ellenberg, R. Oberlin, and T. Tao, “The Kakeya set and maximal conjectures for algebraic varieties over finite fields”, *Mathematika* **56**:1 (2010), 1–25. [MR 2604979](#) [Zbl 1189.42010](#)
- [Griffiths and Harris 1978] P. Griffiths and J. Harris, *Principles of algebraic geometry*, Wiley, New York, 1978. [MR 507725](#) [Zbl 0408.14001](#)
- [Haiman and Sturmfels 2004] M. Haiman and B. Sturmfels, “Multigraded Hilbert schemes”, *J. Algebraic Geom.* **13**:4 (2004), 725–769. [MR 2073194](#) [Zbl 1072.14007](#)
- [Hartshorne 1977] R. Hartshorne, *Algebraic geometry*, Graduate Texts in Mathematics **52**, Springer, New York, 1977. [MR 0463157](#) [Zbl 0367.14001](#)
- [Hochster and Huneke 2002] M. Hochster and C. Huneke, “Comparison of symbolic and ordinary powers of ideals”, *Invent. Math.* **147**:2 (2002), 349–369. [MR 1881923](#) [Zbl 1061.13005](#)
- [Kleiman and Laksov 1972] S. L. Kleiman and D. Laksov, “Schubert calculus”, *Amer. Math. Monthly* **79** (1972), 1061–1082. [MR 0323796](#) [Zbl 0272.14016](#)
- [Miller and Sturmfels 2005] E. Miller and B. Sturmfels, *Combinatorial commutative algebra*, Graduate Texts in Mathematics **227**, Springer, New York, 2005. [MR 2110098](#) [Zbl 1090.13001](#)
- [Wolff 1999] T. Wolff, “Recent work connected with the Kakeya problem”, pp. 129–162 in *Prospects in mathematics* (Princeton, NJ), edited by H. Rossi, Amer. Math. Soc., Providence, RI, 1999. [MR 1660476](#) [Zbl 0934.42014](#)
- [Zhang 2015] R. Zhang, “On configurations where the Loomis–Whitney inequality is nearly sharp and applications to the Furstenberg set problem”, *Mathematika* **61**:1 (2015), 145–161. [MR 3333966](#) [Zbl 06417234](#)

Communicated by Ravi Vakil

Received 2015-04-20

Revised 2016-05-03

Accepted 2016-06-13

ellenber@math.wisc.edu

*Department of Mathematics, University of Wisconsin,
480 Lincoln Drive, Madison, WI 53706, United States*

derman@math.wisc.edu

*Department of Mathematics, University of Wisconsin,
480 Lincoln Drive, Madison, WI 53706, United States*

Local deformation rings for GL_2 and a Breuil–Mézard conjecture when $\ell \neq p$

Jack Shotton

We compute the deformation rings of two dimensional mod l representations of $\mathrm{Gal}(\bar{F}/F)$ with fixed inertial type for l an odd prime, p a prime distinct from l , and F/\mathbb{Q}_p a finite extension. We show that in this setting an analogue of the Breuil–Mézard conjecture holds, relating the special fibres of these deformation rings to the mod l reduction of certain irreducible representations of $\mathrm{GL}_2(\mathcal{O}_F)$.

1. Introduction

Let p be a prime and let F be a finite extension of \mathbb{Q}_p with absolute Galois group G_F . We study the (framed) deformation rings for two-dimensional mod l representations of G_F , where l is an odd prime distinct from p . More specifically, let E be a finite extension of \mathbb{Q}_l with ring of integers \mathcal{O} , uniformiser λ , and residue field \mathbb{F} . Let

$$\bar{\rho} : G_F \rightarrow \mathrm{GL}_2(\mathbb{F})$$

be a continuous representation. Then there is a universal lifting (or framed deformation) ring $R^\square(\bar{\rho})$ parametrising lifts of $\bar{\rho}$. Our main result relates congruences between irreducible components of $\mathrm{Spec} R^\square(\bar{\rho})$ to congruences between certain representations of $\mathrm{GL}_2(\mathcal{O}_F)$, where \mathcal{O}_F is the ring of integers of F . Our method is to give explicit equations for the components of $\mathrm{Spec} R^\square(\bar{\rho})$, which may be of independent use.

If $\tau : I_F \rightarrow \mathrm{GL}_2(E)$ is a continuous representation that extends to a representation of G_F (an *inertial type*), then we say that a representation $\rho : G_F \rightarrow \mathrm{GL}_2(\bar{E})$ has type τ if its restriction to I_F is isomorphic to τ . Say that an irreducible component of $\mathrm{Spec} R^\square(\bar{\rho})$ has type τ if a Zariski dense subset of its \bar{E} -points correspond to representations of type τ . We define (Definition 4.1) a formal sum $\mathcal{C}(\bar{\rho}, \tau)$ of irreducible components of the special fibre $\mathrm{Spec} R^\square(\bar{\rho}) \otimes_{\mathcal{O}} \mathbb{F}$. For semisimple τ , this is obtained as the intersection with the special fibre of those components of $\mathrm{Spec} R^\square(\bar{\rho})$ having type τ ; for nonsemisimple τ this must be slightly modified.

MSC2010: 11S37.

Keywords: Galois representations, deformation rings, local Langlands, Breuil–Mézard.

To an inertial type τ we also associate an irreducible E -representation $\sigma(\tau)$ of $\mathrm{GL}_2(\mathcal{O}_F)$, by a slight variant on the definition of [Henniart 2002] (see Section 3C). For an irreducible \mathbb{F} -representation θ of $\mathrm{GL}_2(\mathcal{O}_F)$, define $m(\theta, \overline{\sigma(\tau)})$ to be the multiplicity of θ as a Jordan–Hölder factor of the mod λ reduction of $\sigma(\tau)$. Then we can state our main theorem:

Theorem 4.2. *Let $\bar{\rho} : G_F \rightarrow \mathrm{GL}_2(\mathbb{F})$ be a continuous representation. For each irreducible \mathbb{F} -representation θ of $\mathrm{GL}_2(\mathcal{O}_F)$, there is a formal sum $\mathcal{C}(\bar{\rho}, \theta)$ of irreducible components of $\mathrm{Spec} R^\square(\bar{\rho}) \otimes \mathbb{F}$ such that, for each inertial type τ , we have the equality*

$$\mathcal{C}(\bar{\rho}, \tau) = \sum_{\theta} m(\theta, \overline{\sigma(\tau)}) \mathcal{C}(\bar{\rho}, \theta).$$

In fact the $\mathcal{C}(\bar{\rho}, \theta)$ are uniquely determined (at least for those θ which actually occur in some $\overline{\sigma(\tau)}$).

This theorem is an analogue for mod l representations of G_F of the Breuil–Mézard conjecture [2002], which pertains to mod p representations of $G_{\mathbb{Q}_p}$. Our statement is not in the language of Hilbert–Samuel multiplicities used in [Breuil and Mézard 2002], but rather in the geometric language of [Emerton and Gee 2014]. The original conjecture of Breuil and Mézard was proved in most cases by Kisin [2009a]; further cases were proved by Paškūnas [2015] by local methods, and the full conjecture was proved when $p > 3$ in [Hu and Tan 2013]. The conjecture was generalised to n -dimensional representations of G_F in [Emerton and Gee 2014]; the only case known, outside of those just mentioned, is that of two-dimensional potentially Barsotti–Tate representations (see [Gee and Kisin 2014]).

In the $l \neq p$ setting, a comparison of special fibres of (very particular) local deformation rings was used by Taylor [2008] to prove the change of level results needed to obtain nonminimal automorphy lifting theorems. This is another motivation for our result.

Our method of proof is to explicitly determine equations for deformation rings of fixed type and, indeed, obtaining these explicit descriptions is another goal of this paper. We reduce to the tamely ramified case, in which we use the relation

$$\phi \sigma \phi^{-1} = \sigma^q,$$

for $\phi \in G_F$ a lift of Frobenius and $\sigma \in I_F$ a generator of tame inertia. Since we are considering lifts ρ of fixed type, and so with fixed characteristic polynomial of $\rho(\sigma)$, we may use the Cayley–Hamilton theorem to reduce this equation to one of degree at most two in the entries of $\rho(\phi)$ and $\rho(\sigma)$. These explicit descriptions show that the irreducible components of $\mathrm{Spec} R^\square(\bar{\rho}) \otimes \bar{E}$ are always smooth (which is also proved in [Pilloni 2008]) and that the reduced deformation rings in which the semisimplification of the restriction to inertia is fixed are always Cohen–Macaulay

(see [Section 5E](#)). It is natural to ask whether these properties persist beyond the case of two-dimensional representations. We note that the generic fibres of our local deformation rings have been studied in [[Pilloni 2008](#); [Reduzzi 2013](#)], but their methods say little about the integral structure.

In a forthcoming paper, we will extend [Theorem 4.2](#) to the case of n -dimensional representations using global methods.

The structure of this paper is as follows. In [Section 2](#) we define the universal deformation rings and show how to reduce their study to the case when $\bar{\rho}$ is tamely ramified. We also prove some lemmas that will be useful in the calculations that follow. In [Section 3](#) we define the deformation rings with fixed inertial type that we will need and discuss the construction of the representations $\sigma(\tau)$. In [Section 4](#) we state and prove the main theorem, modulo the calculations of [Section 5](#) and results of [Section 6](#). [Section 5](#) contains the calculations of explicit equations for local deformation rings, divided into cases according to the value of $q \bmod l$. Finally, in [Section 6](#) we prove the results on the mod l reduction of the $\sigma(\tau)$ that are stated in [Section 3D](#) (and used in the proof of [Theorem 4.2](#)).

2. Preliminaries

2A. Fields and Galois groups. Suppose that $l \neq p$ are primes with $l > 2$.

Let F/\mathbb{Q}_p be a finite extension with ring of integers \mathcal{O}_F , maximal ideal \mathfrak{p}_F , uniformiser ϖ_F , and residue field k_F of order q . Let F have absolute Galois group G_F , inertia group I_F , and wild inertia group P_F . Let $I_F \rightarrow I_F/\tilde{P}_F \cong \mathbb{Z}_l$ be the maximal pro- l quotient of I_F , so that $\tilde{P}_F/P_F \cong \prod_{l' \neq l, p} \mathbb{Z}_{l'}$. Note that \tilde{P}_F is normal in G_F and write $T_F = G_F/\tilde{P}_F$. The short exact sequence $1 \rightarrow I_F/\tilde{P}_F \rightarrow T_F \rightarrow G_F/I_F \rightarrow 1$ splits, so that $T_F \cong \mathbb{Z}_l \rtimes \hat{\mathbb{Z}}$. We fix topological generators σ of this \mathbb{Z}_l and ϕ of this $\hat{\mathbb{Z}}$ such that ϕ is a lift of arithmetic Frobenius. Then the action of $\hat{\mathbb{Z}}$ on \mathbb{Z}_l is given by

$$\phi \sigma \phi^{-1} = \sigma^q. \quad (1)$$

Let L/F be an unramified quadratic extension, with residue field k_L .

Now let E/\mathbb{Q}_l be a finite extension with ring of integers \mathcal{O} , residue field \mathbb{F} and uniformiser λ . Let $\epsilon : G_F \rightarrow \mathbb{Z}_l^\times$ be the l -adic cyclotomic character, and let $\mathbb{1} : G_F \rightarrow \mathbb{Z}_l^\times$ be the trivial character. If A is any \mathcal{O} -algebra then we will regard these as maps to A^\times via the structure maps $\mathbb{Z}_l \rightarrow \mathcal{O} \rightarrow A$.

Define two integers a and b by $a = v_l(q - 1)$ and $b = v_l(q + 1)$, where v_l is the l -adic valuation; at most one of a and b is nonzero since l is odd.

2B. Deformation rings. Suppose that \bar{M} is an n -dimensional \mathbb{F} -vector space and that $\bar{\rho} : G_F \rightarrow GL(\bar{M})$ is a continuous representation. Let $(\bar{e}_i)_{i=1}^n$ be a basis for \bar{M} , so that $\bar{\rho}$ gives a map $\bar{\rho} : G_F \rightarrow GL_n(\mathbb{F})$.

Let $\mathcal{C}_{\mathcal{O}}$ denote the category of artinian local \mathcal{O} -algebras with residue field \mathbb{F} , and $\mathcal{C}_{\mathcal{O}}^{\wedge}$ the category of complete noetherian local \mathcal{O} -algebras with residue field \mathbb{F} . If A is an object of $\mathcal{C}_{\mathcal{O}}$ or $\mathcal{C}_{\mathcal{O}}^{\wedge}$, let \mathfrak{m}_A be its maximal ideal. Define two functors

$$D(\bar{\rho}), D^{\square}(\bar{\rho}) : \mathcal{C}_{\mathcal{O}} \rightarrow \mathbf{Set}$$

as follows:

- $D(\bar{\rho})(A)$ is the set of equivalence classes of (M, ι) where M is a free rank- n A -module, $\rho : G_F \rightarrow \text{Aut}_A(M)$ a continuous homomorphism, and $\iota : M \otimes_A \mathbb{F} \xrightarrow{\sim} \bar{M}$ an isomorphism commuting with the actions of G_F .
- $D^{\square}(\bar{\rho})(A)$ is the set of equivalence classes of $(M, \rho, (e_i)_{i=1}^n)$ where M is a free A -module of rank n , $\rho : G_F \rightarrow \text{Aut}_A(M)$ is a continuous homomorphism, and $(e_i)_{i=1}^n$ is a basis of M as an A -module, such that the isomorphism $\iota : M \otimes_A \mathbb{F} \xrightarrow{\sim} \bar{M}$ defined by $\iota : e_i \otimes 1 \mapsto \bar{e}_i$ commutes with the actions of G_F .

In the first case, (M, ρ, ι) and (M', ρ', ι') are equivalent if there is an isomorphism $\alpha : M \rightarrow M'$, commuting with the actions of G_F , such that $\iota = \iota' \circ \alpha$; in the second case, $(M, \rho, (e_i)_i)$ and $(M', \rho', (e'_i)_i)$ are isomorphic if the map $M \rightarrow M'$ defined by $e_i \mapsto e'_i$ commutes with the actions of G_F . There is a natural transformation of functors $D^{\square}(\bar{\rho}) \rightarrow D(\bar{\rho})$ given by forgetting the basis.

Alternatively, when $\bar{\rho}$ is regarded as a homomorphism to $\text{GL}_n(\mathbb{F})$, we have the equivalent definitions

$$D^{\square}(\bar{\rho})(A) = \{ \rho : G_F \rightarrow \text{GL}_n(A) \mid \rho \text{ is continuous and lifts } \bar{\rho} \}$$

and

$$D(\bar{\rho})(A) = D^{\square}(\bar{\rho})(A) / \text{conjugacy by } 1 + M_n(\mathfrak{m}_A).$$

The functor $D(\bar{\rho})$ is not usually prorepresentable, but the functor $D^{\square}(\bar{\rho})$ always is (see, for example, [Kisin 2009b, 2.3.4]).

Definition 2.1. The *universal lifting ring* (or universal framed deformation ring) of $\bar{\rho}$ is the object $R^{\square}(\bar{\rho})$ of $\mathcal{C}_{\mathcal{O}}^{\wedge}$ that prorepresents the functor $D^{\square}(\bar{\rho})$. The universal lift is denoted $\rho^{\square} : G_F \rightarrow \text{GL}_n(R^{\square}(\bar{\rho}))$.

We recall a useful calculation (see, e.g., [Barnet-Lamb et al. 2014, Section 1.2]):

Lemma 2.2. *The ring $R^{\square}(\bar{\rho})[1/l]$ is generically formally smooth of dimension n^2 .*

The next lemma enables us to reduce to the case where the residual representation is trivial on \tilde{P}_F . Suppose that θ is an irreducible \mathbb{F} -representation of \tilde{P}_F . Then by [Clozel et al. 2008, Lemma 2.4.11] there is a lift of θ to an \mathcal{O} -representation of \tilde{P}_F , which may be extended to an \mathcal{O} -representation $\tilde{\theta}$ of G_{θ} , where G_{θ} is the group $\{g \in G_F \mid g\theta g^{-1} \cong \theta\}$. For each irreducible representation θ of \tilde{P}_F we pick such

a $\tilde{\theta}$ and a finite free \mathcal{O} -module $N(\theta)$ on which \tilde{P}_F acts as $\tilde{\theta}$. If M is a set-finite \mathcal{O} -module with a continuous action ρ of G_F , then define

$$M_\theta = \text{Hom}_{\tilde{P}_F}(\tilde{\theta}, M).$$

The module M_θ has a natural continuous action ρ_θ of G_θ given by $(gf)(v) = gf(g^{-1}v)$; the subgroup \tilde{P}_F of G_θ acts trivially.

Lemma 2.3 (tame reduction). (1) *Let M be a set-finite \mathcal{O} -module with a continuous action of G_F . Then there is a natural isomorphism*

$$M = \bigoplus_{[\theta]} \text{Ind}_{G_\theta}^{G_F}(N(\theta) \otimes_{\mathcal{O}} M_\theta),$$

where θ runs through a set of representatives for the G_F -conjugacy classes of irreducible representations of \tilde{P}_F .

(2) *The isomorphism of part (1) induces a natural isomorphism of functors:*

$$D(\bar{\rho}) \xrightarrow{\sim} \prod_{[\theta]} D(\bar{\rho}_\theta),$$

where θ runs through a set of representatives for the G_F -conjugacy classes of irreducible representations of \tilde{P}_F .

(3) *If $R^\square(\bar{\rho}_\theta)$ is the universal framed deformation ring for the representation $\bar{\rho}_\theta$ of G_θ/\tilde{P}_F , then*

$$R^\square(\bar{\rho}) \cong \left(\widehat{\bigotimes}_{[\theta]} R^\square(\bar{\rho}_\theta) \right) \llbracket X_1, \dots, X_{n^2 - \sum n_\theta^2} \rrbracket,$$

where $n_\theta = \dim \rho_\theta$. This isomorphism lies above $D(\bar{\rho}) \xrightarrow{\sim} \prod_{[\theta]} D(\bar{\rho}_\theta)$, the isomorphism of part (2).

Proof. The first two parts are in [Clozel et al. 2008]: part (1) is Lemma 2.4.12 and part (2) is Corollary 2.4.13. Part (3) is the refinement to framed deformations obtained by keeping track of a basis in the construction of part (1) of the proposition, as in [Choi 2009, Proposition 2.0.5].

As [Choi 2009] is not easily available, we sketch the argument for part (3). Let $[\theta_1], [\theta_2], \dots$ be the G_F -conjugacy classes of irreducible \tilde{P}_F -representations. Pick left coset representatives $(g_{ij})_j$ for G_{θ_i} in G_F . Write N_i for $N(\theta_i)$, and choose an \mathcal{O} -basis $(f_{ik})_k$ of N_i .

Let A be an object of $\mathcal{C}_{\mathcal{O}}$, M be a free rank n A -module with a continuous action of G_F , and M_{θ_i} be as above. Given (for each i) a basis $(e_{il})_{l=1}^{n_{\theta_i}}$ of M_{θ_i} , we can produce a basis $(e_{ijkl})_{j,k,l}$ of

$$M_{\theta_i} = A[G_F] \otimes_{A[G_\theta]} (N_i \otimes_{\mathcal{O}} M_{\theta_i})$$

defined by

$$e_{ijkl} = g_{ij} \otimes f_{ik} \otimes e_{il}.$$

Then $(e_{ijkl})_{i,j,k,l}$ is a basis of M .

Let $\mathcal{F}(A)$ be the set of $\mathbf{Y} = (Y_{ijkl,i'j'k'l'})$ which are $n \times n$ matrices of elements of \mathfrak{m}_A such that

$$Y_{ijkl,i'j'k'l'} = 0 \quad \text{if } i = i' \text{ and } j = j' = k = k' = l$$

(so that $n^2 - \sum n_{\theta_i}^2$ “free” entries of \mathbf{Y} remain). Then \mathcal{F} defines a functor on $\mathcal{C}_{\mathcal{O}}$ prorepresented by $\mathcal{O}[[X_1, \dots, X_{n^2 - \sum n_{\theta_i}^2}]]$ (the variables X being simply an enumeration of those $Y_{ijkl,i'j'k'l'}$ which can be nonzero).

We then have a natural transformation of functors

$$\mathcal{F} \times \prod_{[\theta]} D^{\square}(\bar{\rho}_{\theta}) \rightarrow D^{\square}(\bar{\rho})$$

taking the tuple $(\mathbf{Y}, (M_{\theta_i}, \rho_{\theta_i}, e_{il})_i)$ to the tuple

$$\left(\bigoplus_i \text{Ind}_{G_{\theta_i}}^{G_F}(N_i \otimes_{\mathcal{O}} M_{\theta_i}), \bigoplus_i \text{Ind}_{G_{\theta_i}}^{G_F}(\tilde{\theta}_i \otimes_{\mathcal{O}} \rho_{\theta_i}), (I_n + \mathbf{Y})(e_{ijkl})_{i,j,k,l} \right).$$

Then one can check (and this is what is done in [Choi 2009, Proposition 2.0.5]) that this is in fact an isomorphism, and so we get the claimed isomorphism of prorepresenting objects. \square

2C. Twisting.

Lemma 2.4. *Suppose that $\chi : G_F \rightarrow \mathcal{O}^{\times}$ is any character. Then there is a natural isomorphism*

$$R^{\square}(\bar{\rho}) \xrightarrow{\sim} R^{\square}(\bar{\rho} \otimes \bar{\chi}).$$

Moreover, if χ_1 and χ_2 satisfy $\bar{\chi}_1 = \bar{\chi}_2$ then they induce the same maps

$$R^{\square}(\bar{\rho}) \otimes \mathbb{F} \xrightarrow{\sim} R^{\square}(\bar{\rho} \otimes \bar{\chi}_i) \otimes \mathbb{F}.$$

Proof. This follows easily from the isomorphism of functors

$$D^{\square}(\bar{\rho}) \rightarrow D^{\square}(\bar{\rho} \otimes \bar{\chi})$$

given by tensoring with χ (remembering that we are considering \mathcal{O} -algebras). For the last statement, observe that if the functors are restricted to \mathbb{F} -algebras then the isomorphism only depends on $\bar{\chi}$. \square

Since every \mathbb{F} -valued character lifts to \mathcal{O} (using the Teichmüller lift) this shows that $R^{\square}(\bar{\rho}) \cong R^{\square}(\bar{\rho} \otimes \bar{\chi})$ for every $\bar{\chi} : G_F \rightarrow \mathbb{F}^{\times}$.

We also need the calculation of the universal deformation ring of a character, to which some of our calculations reduce. This is completely standard, but we include it as a simple illustration of the method.

Lemma 2.5. *Let $\bar{\chi} : G_F \rightarrow \mathbb{F}^\times$ be a continuous character. Then*

$$R^\square(\bar{\chi}) = \frac{\mathcal{O}[[X, Y]]}{((1+X)^{l^a} - 1)}$$

has l^a irreducible components, indexed by the l^a -th roots of unity. They are formally smooth of relative dimension one over \mathcal{O} .

Proof. By Lemma 2.4, we may take $\bar{\chi}$ to be trivial. If χ is any lift of $\bar{\chi}$ to an object A of $\mathcal{C}_{\mathcal{O}}$, then for $g \in \tilde{P}_F$ we must have $\chi(g)^n = 1$ for some n coprime to l , and therefore $\chi(g) = 1$, so that we are reduced to considering characters of T_F . We must have that $\chi(\sigma)^q = \chi(\sigma)$ and $\chi(\sigma) \equiv 1 \pmod{\mathfrak{m}_A}$, and therefore that $\chi(\sigma)^{l^a} = 1$. We are then free to choose $\chi(\phi)$. Writing $\chi(\sigma) = 1 + X$ and $\chi(\phi) = 1 + Y$, we have shown that

$$D^\square(\bar{\chi})(A) = \text{Hom}_{\mathcal{C}_{\mathcal{O}}} \left(\frac{\mathcal{O}[[X, Y]]}{((1+X)^{l^a} - 1)}, A \right)$$

functorially, and so the universal framed deformation ring is as claimed. \square

2D. Multiplicities and cycles. Suppose that X is a noetherian scheme and that \mathcal{F} is a coherent sheaf on X . Let Y be the scheme-theoretic support of \mathcal{F} , and let $d \geq \dim Y$. Let $\mathcal{Z}^d(X)$ be the free abelian group on the d -dimensional points of X ; elements of $\mathcal{Z}^d(X)$ are called d -dimensional cycles. If $\mathfrak{a} \in X$ is a point of dimension d write $[\mathfrak{a}]$ for the corresponding element of $\mathcal{Z}^d(X)$ and define the multiplicity $e(\mathcal{F}, \mathfrak{a})$ to be the length of $\mathcal{F}_{\mathfrak{a}}$ as an $\mathcal{O}_{Y, \mathfrak{a}}$ -module (this is zero if $\mathfrak{a} \notin Y$).

Definition 2.6. The cycle $Z^d(\mathcal{F})$ associated to \mathcal{F} is the element

$$\sum_{\mathfrak{a}} e(\mathcal{F}, \mathfrak{a})[\mathfrak{a}] \in \mathcal{Z}^d(X).$$

If $X = \text{Spec } A$ is affine and $\mathcal{F} = \tilde{M}$ for a finitely generated A -module M , then we will write $Z^d(M)$ for $Z^d(\mathcal{F})$.

If $i : X \rightarrow X'$ is a closed immersion of X in a noetherian scheme X' , then there is a natural inclusion $i_* : \mathcal{Z}^d(X) \rightarrow \mathcal{Z}^d(X')$ for each d . For a coherent sheaf \mathcal{F} on X whose support has dimension at most d , we then have

$$i_*(Z^d(\mathcal{F})) = Z^d(i_*(\mathcal{F})).$$

We will often use this compatibility without comment.

A cycle is *effective* if it is of the form $\sum n_{\mathfrak{a}}[\mathfrak{a}]$ for $n_{\mathfrak{a}} \geq 0$. We say that an effective cycle C_1 is a *subcycle* of an effective cycle C_2 if $C_2 - C_1$ is also effective.

2E. A determinantal ring. For a, b , and c natural numbers, if I is the ideal generated by the $a \times a$ minors of a $b \times c$ matrix with independent indeterminate entries over a Cohen–Macaulay ring A , then A/I is always Cohen–Macaulay (see [Eisenbud 1995, Theorem 18.18]). We include a simple proof in the very special case that we need below.

Proposition 2.7. *Let $k \geq 2$ be an integer and let A be either a field or a discrete valuation ring. Let $R = A[X_1, \dots, X_k, Y_1, \dots, Y_k]$ and let $I \triangleleft R$ be the ideal generated by the 2×2 minors of*

$$\begin{pmatrix} X_1 & X_2 & \cdots & X_k \\ Y_1 & Y_2 & \cdots & Y_k \end{pmatrix}.$$

Let $S = R/I$. Then S is a Cohen–Macaulay domain and is flat over A . It is Gorenstein if and only if $k = 2$.

The same is true if we replace S by its completion S^\wedge at the “irrelevant” ideal $(X_1, \dots, X_k, Y_1, \dots, Y_k)$.

Proof. Note that R and S are naturally graded A -algebras.

Suppose that A is a field. It is easy to see that $\text{Proj}(S)$ is a smooth irreducible projective variety over A of dimension $k + 1$ — it is covered by the open sets $\{X_i \neq 0\}$ and $\{Y_i \neq 0\}$, each of which is isomorphic to $(\mathbb{A}_A^1 \setminus \{0\}) \times \mathbb{A}_A^k$. Thus S is a domain. We may extend A so that its cardinality is at least $k + 1$, and choose pairwise distinct $\alpha_1, \dots, \alpha_k \in A^\times$.

I claim that $(X_1 - \alpha_1 Y_1, \dots, X_k - \alpha_k Y_k, Y_1 + \dots + Y_k)$ is a regular sequence in S . To see this, observe that $\text{Proj}(S/(X_1 - \alpha_1 Y_1, \dots, X_i - \alpha_i Y_i))$ is reduced (we may check this on the affine pieces) and that its irreducible components are all of the form

$$\text{Proj}\left(\frac{R}{(X_j - \alpha_{i_0} Y_j)_{1 \leq j \leq k} + (X_j, Y_j)_{1 \leq j \leq i, j \neq i_0}}\right),$$

for $1 \leq i_0 \leq i$ or of the form

$$\text{Proj}(S/(X_1, \dots, X_i, Y_1, \dots, Y_i)).$$

Now it is easy to check that $X_{i+1} - \alpha_{i+1} Y_{i+1}$ (if $i < k$) or $Y_1 + \dots + Y_k$ (if $i = k$) is a nonzerodivisor on each of these components, and so is a nonzerodivisor on $S/(X_1 - \alpha_1 Y_1, \dots, X_i - \alpha_i Y_i)$ as required.

Now

$$S/((X_i - \alpha_i Y_i)_i, Y_1 + \dots + Y_k) \cong A[Y_2, \dots, Y_k]/(Y_2, \dots, Y_k)^2$$

is Gorenstein if and only if $k = 2$, as required.

If A is a DVR then the following easy lemma (a specialisation of [Snowden 2011, Proposition 2.2.1]) gives the result.

Lemma 2.8. *If A is a DVR and S is a finitely generated A -algebra such that $S \otimes A/\mathfrak{m}_A$ and $S \otimes \text{Frac } A$ are domains of the same dimension, then S is flat over A (that is, a uniformiser of A is a regular parameter in S).*

The final statement of the proposition follows from the facts that both localisation and completion preserve the properties of being Gorenstein, Cohen–Macaulay, or A -flat; S^\wedge is a domain because its associated graded ring is S , which is a domain. \square

3. Types

3A. Inertial types.

Definition 3.1. An *inertial type* τ (of dimension n) is an equivalence class of pairs (r_τ, N_τ) such that:

- $r_\tau : I_F \rightarrow GL_n(\bar{E})$ is a representation with open kernel.
- N_τ is a nilpotent $n \times n$ matrix over \bar{E} .
- (r_τ, N_τ) extends to a Weil–Deligne representation of G_F .

In particular, N_τ commutes with the image of r_τ . Two such pairs are equivalent if they are conjugate by an element of $GL_n(\bar{E})$.

We say that a continuous representation $\rho : G_F \rightarrow GL_n(\bar{E})$ has inertial type τ if the restriction to inertia of the associated Weil–Deligne representation is equivalent to τ .

We define some particular two-dimensional types which will often arise. They will all be of the form (r, N) with $r|_{\tilde{P}_F}$ trivial, and are therefore determined by $r(\sigma)$ and N . Define:

- $\tau_{\zeta, s}$ by $r(\sigma) = \begin{pmatrix} \zeta & 0 \\ 0 & \zeta \end{pmatrix}$ and $N = 0$, where ζ is an l^a -th root of unity (s is for “split”).
- $\tau_{\zeta, ns}$ by $r(\sigma) = \begin{pmatrix} \zeta & 0 \\ 0 & \zeta \end{pmatrix}$ and $N = \begin{pmatrix} 0 & 1 \\ 0 & 0 \end{pmatrix}$ where ζ is an l^a -th root of unity (ns is for “nonsplit”).
- τ_{ζ_1, ζ_2} by $r(\sigma) = \begin{pmatrix} \zeta_1 & 0 \\ 0 & \zeta_2 \end{pmatrix}$ and $N = 0$ where, ζ_1 and ζ_2 are distinct l^a -th roots of unity.
- τ_ξ by $r(\sigma) = \begin{pmatrix} \xi & 0 \\ 0 & \xi^{-1} \end{pmatrix}$ and $N = 0$ where, ξ is a *nontrivial* l^b -th root of unity.

To see that τ_ξ is a type, note that if L/F is the unramified quadratic extension, then there is a character of G_L/\tilde{P}_F mapping σ to ξ , which when induced to G_F gives a representation of type τ_ξ .

3B. Deformation rings with fixed type.

Definition 3.2. Let τ be an inertial type. Then $R^\square(\bar{\rho}, \tau)$ is the maximal reduced, l -torsion free quotient of $R^\square(\bar{\rho})$ with the following property: if $x : R^\square(\bar{\rho}) \rightarrow GL_n(\bar{E})$ is a continuous homomorphism such that the associated representation $\rho_x : G_F \rightarrow GL_n(\bar{E})$ has type τ , then x factors through $R^\square(\bar{\rho}, \tau)$.

The rings $R^\square(\bar{\rho}) \otimes \mathbb{F}$ and $R^\square(\bar{\rho}, \tau) \otimes \mathbb{F}$ will occur very often, and so we denote them respectively by $\bar{R}^\square(\bar{\rho})$ and $\bar{R}^\square(\bar{\rho}, \tau)$.

From now on suppose that $n = 2$. Write $\tau = (r_\tau, N_\tau)$ and assume that E is large enough that all of the roots of the characteristic polynomial of r_τ lie in E . Let $R^\square(\bar{\rho}, \tau)^\circ$ be the maximal quotient of $R^\square(\bar{\rho})$ on which:

- If r_τ is not scalar then, for all $g \in I_F$, the characteristic polynomial of $\rho^\square(g)$ agrees with that of r_τ .
- If r_τ is scalar and $N_\tau = 0$ then, for all $g \in I_F$, $\rho^\square(g)$ is scalar and agrees with r_τ .
- If r_τ is scalar and $N_\tau \neq 0$ then, for all $g \in I_F$, the characteristic polynomial of $\rho^\square(g)$ agrees with that of r_τ . Moreover, we have

$$q(\text{tr } \rho^\square(\phi))^2 = (q + 1)^2 \det(\rho^\square(\phi)). \tag{2}$$

It is clear that these quotients exist and that the conditions imposed are deformation problems for $\bar{\rho}$.

Lemma 3.3. *The ring $R^\square(\bar{\rho}, \tau)$ is a reduced l -torsion free quotient of $R^\square(\bar{\rho}, \tau)^\circ$.*

If $N_\tau = 0$, then we have that $R^\square(\bar{\rho}, \tau)$ is equal to the maximal reduced l -torsion free quotient of $R^\square(\bar{\rho}, \tau)^\circ$.

Proof. The first part is clear unless r_τ is scalar and $N_\tau \neq 0$. In this case, we must show that any representation $\rho : G_F \rightarrow \text{GL}_2(\bar{E})$ of type τ satisfies equation (2). The Weil–Deligne representation (r, N) corresponding to such a ρ satisfies $r|_{I_F} = r_\tau$ and $N \neq 0$. Then $r(\phi)N = qNr(\phi)$ implies that $r(\phi)$ preserves the line $\ker N$ and the quotient $\bar{E}^2 / \ker N$. If it acts as α on the former and β on the latter then we must have $\alpha = q\beta$; as α and β are the eigenvalues of $\rho(\phi)$ equation (2) is easily verified.

The final claim follows from the simple observation that any \bar{E} -point of $R^\square(\bar{\rho}, \tau)^\circ$ has associated Galois representation of type τ , except perhaps if r_τ is scalar and $N_\tau \neq 0$. □

Remark 3.4. If R is a reduced, l -torsion free quotient of $R^\square(\bar{\rho})$ such that $R^\square(\bar{\rho}, \tau)$ is a quotient of R , then $R = R^\square(\bar{\rho}, \tau)$ if and only if the closed points of type τ are Zariski dense in $\text{Spec } R[1/l]$. In our calculations, when this is true it will always be clear by inspection.

3C. K -types. Let $G = \text{GL}_2(F)$, $K = \text{GL}_2(\mathcal{O}_F)$, and for $N \geq 1$ let $K(N) = 1 + M_2(\mathfrak{p}_F^N)$ and $K_0(N) = \left\{ \begin{pmatrix} a & b \\ c & d \end{pmatrix} : c \in \mathfrak{p}_F^N \right\}$. Let $U_0 = \mathcal{O}_F^\times$ and for $N \geq 1$ let $U_N = 1 + \mathfrak{p}_F^N$. The *exponent* of a character χ of \mathcal{O}_F^\times is the smallest $N \geq 0$ such that χ is trivial on U_N . If π is an irreducible admissible representation of $\text{GL}_m(F)$ (we only need $m = 1$ and $m = 2$) over \bar{E} , let $\text{rec}(\pi)$ be the continuous representation of W_F over \bar{E} associated to π under the local Langlands correspondence (normalised so as to be preserved by automorphisms of \bar{E}).

For each two-dimensional inertial type $\tau = (r_\tau, N_\tau)$, we define an irreducible representation $\sigma(\tau)$ by the following recipe:

- If $\tau = \tau_{1,s}$, then $\sigma(\tau)$ is the trivial representation of K .
- If $\tau = \tau_{1,ns}$, then $\sigma(\tau)$ is the inflation to K of the Steinberg representation St of $GL_2(k_F)$.
- If $\tau = (\mathbb{1} \oplus \text{rec}(\epsilon)|_{I_F}, 0)$ for a nontrivial character ϵ of F^\times of exponent N , then

$$\sigma(\tau) = \text{Ind}_{K_0(N)}^K \epsilon,$$

where $\epsilon\left(\begin{pmatrix} a & b \\ c & d \end{pmatrix}\right) = \epsilon(a)$.

- If $\tau = (\text{rec}(\pi)|_{I_F}, 0)$ for a cuspidal representation π of $GL_2(F)$, then by [Bushnell and Henniart 2006, Theorem 15.5] there is a certain subgroup $J \subset G$, containing the centre of G and compact modulo centre, and a representation Λ of J such that

$$\pi = \text{c-Ind}_J^G \Lambda.$$

By conjugating, we may suppose that the maximal compact subgroup J^0 of J is contained in K . We then have

$$\sigma(\tau) = \text{Ind}_{J^0}^K (\Lambda|_{J^0}).$$

- If $\tau = \tau' \otimes \text{rec}(\chi)|_{I_F}$, then $\sigma(\tau) = \sigma(\tau') \otimes (\chi|_{U_0} \circ \det)$.

This is a slightly modified version of the construction in [Henniart 2002] — the construction there only depends on r_τ , and agrees with ours whenever r_τ is not scalar. The following is an easy consequence of [Henniart 2002]:

Proposition 3.5. *If $\sigma(\tau)$ is contained in an irreducible admissible representation π of $GL_2(F)$ and $\text{rec}(\pi) = (r, N)$, then $r|_{I_F} \cong r_\tau$ and either $N \cong N_\tau$ or $N_\tau \neq 0$ and $N = 0$.*

If π is infinite-dimensional, then the converse is true.

3D. Reduction of types. Suppose that $\bar{r} : I_F \rightarrow GL_2(\bar{\mathbb{F}})$ is such that \bar{r} extends to G_F .

Definition 3.6. The set $L(\bar{r})$ is the set of types τ such that there exists a representation $\rho : G_F \rightarrow GL_2(\mathcal{O}_{\bar{E}})$ of type τ satisfying

$$\bar{\rho}|_{I_F} \cong \bar{r}.$$

If $\bar{r}|_{\tilde{P}_F}$ is nonscalar then we abuse notation and also write $L(\bar{r})$ for the set of r such that $(r, 0) \in L(\bar{r})$, as in this case every element of $L(\bar{r})$ is of this form.

Lemma 3.7. *Suppose that \bar{r} is trivial on \tilde{P}_F . Then each element of $L(\bar{r})$ is one of the types $\tau_{\zeta,s}$, $\tau_{\zeta,ns}$, τ_{ζ_1,ζ_2} , τ_ξ defined in Section 3A.*

Proof. Suppose that $\rho : G_F \rightarrow \mathrm{GL}_2(\mathcal{O}_{\bar{E}})$ is of type τ and is such that $\bar{\rho}|_{I_F} \cong \bar{r}$. As $\bar{r}|_{\tilde{P}_F}$ is trivial, ρ must also be trivial on \tilde{P}_F and its type is determined by the eigenvalues of $\rho(\sigma)$ and by a nilpotent matrix N commuting with $\rho(\sigma)$. Now, the fundamental relation $\phi\sigma\phi^{-1} = \sigma^q$ shows that the eigenvalues of $\rho(\sigma)$ are the same (but perhaps in a different order) as those of $\rho(\sigma)^q$, and this implies that they are $(q^2 - 1)$ -th roots of unity. Moreover, they are congruent to 1 modulo the maximal ideal of $\mathcal{O}_{\bar{E}}$, and so must in fact be either l^a -th or l^b -th roots of unity (recall that at most one of a and b is nonzero, since $l \neq 2$). If they are distinct l^a -th roots of unity, then N must be zero and $\tau = \tau_{\zeta_1, \zeta_2}$; if they are equal l^a -th roots of unity then $\tau = \tau_{\zeta, s}$ or $\tau_{\zeta, ns}$; if they are l^b -th roots of unity then they must be ξ and $\xi^q = \xi^{-1}$ for an l^b -th root of unity ξ . Moreover the case $\xi = 1$ has already been dealt with and so we may assume that $\xi \neq 1$, in which case $N = 0$ and $\tau = \tau_{\xi}$. \square

- Lemma 3.8.** (1) *Suppose that $\bar{r}|_{\tilde{P}_F}$ is irreducible. There is a lift r of \bar{r} to $\mathrm{GL}_2(\bar{E})$, which we fix. Then $L(\bar{r}) = \{r \otimes \chi\}_{\chi}$ as χ runs over the set of characters $\chi : I_F \rightarrow \bar{E}^{\times}$ which extend to G_F and reduce to the trivial character.*
- (2) *Suppose that $\bar{r}|_{\tilde{P}_F} \cong (\bar{r}_1 \oplus \bar{r}_2)|_{\tilde{P}_F}$ where \bar{r}_1 and \bar{r}_2 are distinct characters of G_F . There are lifts r_1 and r_2 of \bar{r}_1 and \bar{r}_2 to \bar{E}^{\times} , which we fix. Then $L(\bar{r}) = \{(r_1|_{I_F} \otimes \chi_1) \oplus (r_2|_{I_F} \otimes \chi_2)\}_{\chi_1, \chi_2}$ where χ_1, χ_2 run over all pairs of characters $I_F \rightarrow \bar{E}^{\times}$ which extend to G_F and reduce to the trivial character.*
- (3) *Suppose that $\bar{r}|_{\tilde{P}_F} \cong (\bar{r}_1 \oplus \bar{r}_1^c)|_{\tilde{P}_F}$ where \bar{r}_1 and \bar{r}_1^c are distinct characters of G_L which are conjugate by an element of G_F (recall that L/F is the unramified quadratic extension). There is a lift r_1 of \bar{r}_1 to \bar{E}^{\times} . Then $L(\bar{r}) = \{(r_1|_{I_F} \otimes \chi) \oplus (r_1^c|_{I_F} \otimes \chi^c)\}_{\chi}$ as χ runs over all characters $I_F \rightarrow \bar{E}^{\times}$ which extend to G_L and reduce to the trivial character.*

Proof. This follows from Proposition 5.1 below; the ingredients in the proof of that proposition are Lemma 2.3 (reduction to the tame case) and Lemma 2.4 (lifting ring of a character). \square

Lemma 3.9. *If $\tau = (r, 0)$ is an inertial type with $r|_{\tilde{P}_F}$ nonscalar, then $\overline{\sigma(\tau)}$ is irreducible. If τ' is any other inertial type, then $\overline{\sigma(\tau')}$ contains $\overline{\sigma(\tau)}$ if and only if $\tau' \in L(\bar{r})$ (in which case $\overline{\sigma(\tau)} \cong \overline{\sigma(\tau')}$).*

Proof. These are the results of Propositions 6.4 and 6.5. \square

If $\tau = (r, N)$ with $r|_{\tilde{P}_F}$ scalar, then $\overline{\sigma(\tau)}$ need not be irreducible. We give the (well-known) analysis of these $\overline{\sigma(\tau)}$ in Section 6A. For now, we just give names to the following representations of $\mathrm{GL}_2(k_F)$ (and hence, by inflation, of K) over \mathbb{F}

- the trivial representation, $\mathbb{1}$,
- the Steinberg representation, St (irreducible if $q \not\equiv -1 \pmod{l}$),
- if $q \equiv -1 \pmod{l}$, the cuspidal (but not supercuspidal) subrepresentation π_1 of St .

4. The “Breuil–Mézard conjecture”

Let $\bar{\rho} : G_F \rightarrow GL_2(\mathbb{F})$ be a continuous representation, and suppose that E is sufficiently large that

- every subrepresentation of $\bar{\rho} \otimes \bar{\mathbb{F}}$ is already defined over \mathbb{F} ,
- E contains all of the $(q^2 - 1)$ -th roots of unity,
- for every $\tau \in L(\bar{\rho}|_{I_F})$, $\sigma(\tau)$ is defined over E .

We state our analogue of the Breuil–Mézard conjecture when $l \neq p$. By [Lemma 2.2](#) and the fact that $R^\square(\bar{\rho}, \tau)$ is defined to be \mathcal{O} -flat, we have

$$\dim \bar{R}^\square(\bar{\rho}, \tau) \leq 4.$$

Definition 4.1. We associate to each type $\tau = (r, N)$ a cycle $\mathcal{C}(\bar{\rho}, \tau) \in \mathcal{Z}^4(\bar{R}^\square(\bar{\rho}))$ as follows:

- If $N = 0$, set

$$\mathcal{C}(\bar{\rho}, \tau) = Z^4(\bar{R}^\square(\bar{\rho}, \tau)).$$

- If $N \neq 0$ (in which case r must be scalar) let $\tau' = (r, 0)$ and set

$$\mathcal{C}(\bar{\rho}, \tau) = Z^4(\bar{R}^\square(\bar{\rho}, \tau)) + Z^4(\bar{R}^\square(\bar{\rho}, \tau')).$$

Theorem 4.2. For each irreducible $\bar{\mathbb{F}}$ -representation θ of $GL_2(\mathcal{O}_F)$, there is an effective cycle $\mathcal{C}(\bar{\rho}, \theta) \in \mathcal{Z}^4(\bar{R}^\square(\bar{\rho}))$ such that, for any inertial type τ , we have an equality of cycles

$$\mathcal{C}(\bar{\rho}, \tau) = \sum_{\theta} m(\theta, \overline{\sigma(\tau)}) \mathcal{C}(\bar{\rho}, \theta), \tag{3}$$

where $m(\theta, \overline{\sigma(\tau)})$ is the multiplicity of θ as a Jordan–Hölder factor of $\overline{\sigma(\tau)}$ and the sum runs over all θ .

Proof. We proceed case by case, using the results of [Section 3D](#) and of [Sections 5](#) and [6A](#) below.

Suppose that $\bar{\rho}|_{\tilde{p}_F}$ is nonscalar. Then by [Lemma 3.9](#), the representations $\overline{\sigma(\tau)}$ for $\tau \in L(\bar{\rho}|_{I_F})$ are all irreducible and isomorphic to a common irreducible representation, which we call θ_0 . By [Corollary 5.2](#), $\bar{R}^\square(\bar{\rho})$ has a unique minimal prime, denoted \mathfrak{a} , which has dimension 4. So we have

$$\mathcal{Z}^4(\text{Spec}(\bar{R}^\square(\bar{\rho}))) = \mathbb{Z} \cdot [\mathfrak{a}].$$

Define $\mathcal{C}(\bar{\rho}, \theta_0) = [\mathfrak{a}]$ and $\mathcal{C}(\bar{\rho}, \theta) = 0$ for $\theta \neq \theta_0$. By [Corollary 5.2](#),

$$\mathcal{C}(\bar{\rho}, \tau) = [\mathfrak{a}] = \mathcal{C}(\bar{\rho}, \theta_0)$$

if $\tau \in L(\bar{\rho}|_{\tilde{p}_F})$, otherwise

$$\mathcal{C}(\bar{\rho}, \tau) = 0.$$

In other words, for all τ we have

$$\mathcal{C}(\bar{\rho}, \tau) = \sum_{\theta} m(\theta, \overline{\sigma(\tau)}) \mathcal{C}(\bar{\rho}, \theta),$$

as required.

If $\bar{\rho}|_{\bar{F}}$ is scalar, then we may twist $\bar{\rho}$ by a character of G_F and apply [Lemma 2.4](#) and so *suppose for the rest of the proof that $\bar{\rho}|_{\bar{F}}$ is trivial.*

If $q \not\equiv \pm 1 \pmod{l}$, then $L(\bar{\rho}|_{I_F}) \subset \{\tau_{1,s}, \tau_{1,ns}\}$. By the discussion of [Section 6A](#), we have that

$$\overline{\sigma(\tau_{1,s})} = \mathbb{1} \quad \text{and} \quad \overline{\sigma(\tau_{1,ns})} = \text{St}$$

are irreducible and nonisomorphic, and that neither is a Jordan–Hölder factor of any other $\overline{\sigma(\tau)}$. So the fact that we *can* define the $\mathcal{C}(\bar{\rho}, \theta)$ so as to satisfy [\(3\)](#) is a triviality, as there are no relations amongst the $\overline{\sigma(\tau)}$ for different τ . We work out what the $\mathcal{C}(\bar{\rho}, \theta)$ are explicitly: for $\theta \neq \mathbb{1}$ or St we define $\mathcal{C}(\bar{\rho}, \theta) = 0$. Otherwise, there are four cases to consider:

- If $\bar{\rho}(\phi)$ has eigenvalues with ratio not in $\{1, \pm q\}$ then by [Proposition 5.3](#) there is a unique minimal prime \mathfrak{a}_{nr} of $\bar{R}^\square(\bar{\rho})$. In this case, define

$$\mathcal{C}(\bar{\rho}, \mathbb{1}) = [\mathfrak{a}_{nr}], \quad \mathcal{C}(\bar{\rho}, \text{St}) = [\mathfrak{a}_{nr}].$$

- If $\bar{\rho}$ is an extension of the trivial character by itself then by [Proposition 5.5](#) part 1 there is a unique minimal prime \mathfrak{a}_{nr} of $\bar{R}^\square(\bar{\rho})$. In this case, define

$$\mathcal{C}(\bar{\rho}, \mathbb{1}) = [\mathfrak{a}_{nr}], \quad \mathcal{C}(\bar{\rho}, \text{St}) = [\mathfrak{a}_{nr}].$$

- If $\bar{\rho}$ is a nonsplit extension of the trivial character by the cyclotomic character then by [Proposition 5.5](#) part 2 there is a unique minimal prime \mathfrak{a}_N of $\bar{R}^\square(\bar{\rho})$. In this case, define

$$\mathcal{C}(\bar{\rho}, \mathbb{1}) = 0, \quad \mathcal{C}(\bar{\rho}, \text{St}) = [\mathfrak{a}_N].$$

- If $\bar{\rho}$ is the direct sum of the trivial character and the cyclotomic character then by [Proposition 5.5](#) part 2 there are two minimal primes of $\bar{R}^\square(\bar{\rho})$, denoted there by \mathfrak{a}_{nr} and \mathfrak{a}_N . In this case, define

$$\mathcal{C}(\bar{\rho}, \mathbb{1}) = [\mathfrak{a}_{nr}], \quad \mathcal{C}(\bar{\rho}, \text{St}) = [\mathfrak{a}_{nr}] + [\mathfrak{a}_N].$$

It is then easy to verify that equation [\(3\)](#) holds; we just do the last case. We see from [Proposition 5.5](#) part 2 that

$$\mathcal{C}(\bar{\rho}, \tau_{1,s}) = [\mathfrak{a}_{nr}] = \mathcal{C}(\bar{\rho}, \mathbb{1}), \quad \mathcal{C}(\bar{\rho}, \tau_{1,ns}) = [\mathfrak{a}_{nr}] + [\mathfrak{a}_N] = \mathcal{C}(\bar{\rho}, \text{St}),$$

and $\mathcal{C}(\bar{\rho}, \tau) = 0$ for all other τ , exactly as required by [\(3\)](#).

If $q \equiv -1 \pmod{l}$, then $L(\bar{\rho}|_{I_F}) \subset \bigcup_{\xi} \{\tau_{1,s}, \tau_{1,ns}, \tau_{\xi}\}$ for ξ a nontrivial l^b -th root of unity. By the discussion of [Section 6A](#), we have that

$$\overline{\sigma(\tau_{1,s})} = \mathbb{1}, \quad \overline{\sigma(\tau_{\xi})} = \pi_1, \quad \overline{\sigma(\tau_{1,ns})}^{ss} = \mathbb{1} \oplus \pi_1,$$

where $\mathbb{1}$ and π_1 are irreducible and nonisomorphic, and are not Jordan–Hölder factors of any other $\overline{\sigma(\tau)}$. For $\theta \neq \mathbb{1}$ or π_1 we define $\mathcal{C}(\bar{\rho}, \theta) = 0$. Otherwise, there are four cases to consider:

- If $\bar{\rho}(\phi)$ has eigenvalues with ratio not in $\{\pm 1\}$ then by [Proposition 5.3](#) there is a unique minimal prime \mathfrak{a}_{nr} of $\bar{R}^{\square}(\bar{\rho})$. In this case, define

$$\mathcal{C}(\bar{\rho}, \mathbb{1}) = [\mathfrak{a}_{nr}], \quad \mathcal{C}(\bar{\rho}, \pi_1) = 0.$$

- If $\bar{\rho}$ is an extension of the trivial character by itself then by [Proposition 5.6](#) part 1 there is a unique minimal prime \mathfrak{a}_{nr} of $\bar{R}^{\square}(\bar{\rho})$. In this case, define

$$\mathcal{C}(\bar{\rho}, \mathbb{1}) = [\mathfrak{a}_{nr}], \quad \mathcal{C}(\bar{\rho}, \pi_1) = 0.$$

- If $\bar{\rho}$ is a nonsplit extension of the trivial character by the cyclotomic character then by [Proposition 5.6](#) part 2a there is a unique minimal prime, denoted \mathfrak{a}_N in that proposition, of $\bar{R}^{\square}(\bar{\rho}, \tau_{1,ns})$, which we regard as a prime of $\bar{R}^{\square}(\bar{\rho})$. In this case, define

$$\mathcal{C}(\bar{\rho}, \mathbb{1}) = 0, \quad \mathcal{C}(\bar{\rho}, \pi_1) = [\mathfrak{a}_N].$$

- If $\bar{\rho}$ is the direct sum of the trivial character by the cyclotomic character then in [Proposition 5.6](#) part 2b three four-dimensional primes of $\bar{R}^{\square}(\bar{\rho})$ are defined, denoted there \mathfrak{a}_{nr} , \mathfrak{a}_N and $\mathfrak{a}_{N'}$. In this case, define

$$\mathcal{C}(\bar{\rho}, \mathbb{1}) = [\mathfrak{a}_{nr}], \quad \mathcal{C}(\bar{\rho}, \pi_1) = [\mathfrak{a}_N] + [\mathfrak{a}_{N'}].$$

It is then easy to verify that [\(3\)](#) holds using [Proposition 5.3](#) in the first case and [Proposition 5.6](#) parts 1, 2a, and 2b in the second, third, and fourth cases; again we just do the fourth case, which is the most complicated. [Equation \(3\)](#) is equivalent to the equations

$$\begin{aligned} \mathcal{C}(\bar{\rho}, \tau_{1,s}) &= \mathcal{C}(\bar{\rho}, \mathbb{1}) &&= [\mathfrak{a}_{nr}], \\ \mathcal{C}(\bar{\rho}, \tau_{1,ns}) &= \mathcal{C}(\bar{\rho}, \mathbb{1}) + \mathcal{C}(\bar{\rho}, \pi_1) &&= [\mathfrak{a}_{nr}] + [\mathfrak{a}_N] + [\mathfrak{a}_{N'}], \\ \mathcal{C}(\bar{\rho}, \tau_{\xi}) &= \mathcal{C}(\bar{\rho}, \pi_1) &&= [\mathfrak{a}_N] + [\mathfrak{a}_{N'}], \end{aligned}$$

and

$$\mathcal{C}(\bar{\rho}, \tau) = 0 \quad \text{if } \tau \notin \bigcup_{\xi} \{\tau_{1,s}, \tau_{1,ns}, \tau_{\xi}\}.$$

But by [Proposition 5.6](#) part 2b we have

$$\begin{aligned} \mathcal{C}(\bar{\rho}, \tau_{1,s}) &= Z^4(\bar{R}(\bar{\rho}, \tau_{1,s})) &&= [\mathfrak{a}_{nr}], \\ \mathcal{C}(\bar{\rho}, \tau_{1,ns}) &= Z^4(\bar{R}(\bar{\rho}, \tau_{1,s})) + Z^4(\bar{R}(\bar{\rho}, \tau_{1,ns})) &&= [\mathfrak{a}_{nr}] + [\mathfrak{a}_N] + [\mathfrak{a}_{N'}], \\ \mathcal{C}(\bar{\rho}, \tau_\xi) &= Z^4(\bar{R}(\bar{\rho}, \tau_\xi)) &&= [\mathfrak{a}_N] + [\mathfrak{a}_{N'}], \end{aligned}$$

and

$$\mathcal{C}(\bar{\rho}, \tau) = 0 \quad \text{if } \tau \notin \bigcup_\xi \{\tau_{1,s}, \tau_{1,ns}, \tau_\xi\},$$

as required.

If $q \equiv 1 \pmod{l}$, then $L(\bar{\rho}|_{I_F}) \subset \bigcup_{\zeta, \zeta_1, \zeta_2} \{\tau_{\zeta,s}, \tau_{\zeta,ns}, \tau_{\zeta_1, \zeta_2}\}$ for ζ, ζ_1 and ζ_2 (possibly trivial) l^a -th roots of unity with $\zeta_1 \neq \zeta_2$. By the discussion of [Section 6A](#), we have that

$$\overline{\sigma(\tau_{\zeta,s})} = \mathbb{1}, \quad \overline{\sigma(\tau_{\zeta,ns})} = \text{St}, \quad \overline{\sigma(\tau_{\zeta_1, \zeta_2})} = \mathbb{1} \oplus \text{St},$$

where $\mathbb{1}$ and St are irreducible and nonisomorphic, and are not Jordan–Hölder factors of any other $\overline{\sigma(\tau)}$. For $\theta \neq \mathbb{1}$ or St we define $\mathcal{C}(\bar{\rho}, \theta) = 0$. Otherwise, there are four cases to consider:

- If $\bar{\rho}(\phi)$ has eigenvalues with ratio not in $\{\pm 1\}$ then by [Proposition 5.3](#) there is a unique minimal prime \mathfrak{a}_{nr} of $\bar{R}^\square(\bar{\rho})$. In this case, define

$$\mathcal{C}(\bar{\rho}, \mathbb{1}) = [\mathfrak{a}_{nr}], \quad \mathcal{C}(\bar{\rho}, \text{St}) = [\mathfrak{a}_{nr}].$$

- If $\bar{\rho}$ is a ramified extension of the trivial character by itself then by [Proposition 5.8](#) part 1 there is a unique minimal prime \mathfrak{a}_N of $\bar{R}^\square(\bar{\rho}, \tau_{1,ns})$ which we regard as a four-dimensional prime of $\bar{R}^\square(\bar{\rho})$. In this case, define

$$\mathcal{C}(\bar{\rho}, \mathbb{1}) = 0, \quad \mathcal{C}(\bar{\rho}, \text{St}) = [\mathfrak{a}_N].$$

- If $\bar{\rho}$ is a unramified extension of the trivial character by itself then by [Proposition 5.8](#) parts 2 and 3 there are four-dimensional primes of $\bar{R}^\square(\bar{\rho})$ which are denoted there by $[\mathfrak{a}_{nr}]$ and $[\mathfrak{a}_N]$. In this case, define

$$\mathcal{C}(\bar{\rho}, \mathbb{1}) = [\mathfrak{a}_{nr}], \quad \mathcal{C}(\bar{\rho}, \text{St}) = [\mathfrak{a}_{nr}] + [\mathfrak{a}_N].$$

It is then easy to verify that [\(3\)](#) holds using [Proposition 5.3](#) in the first case, [Proposition 5.8](#) part 1 in the second case, and [Proposition 5.8](#) parts 2 and 3 in the third case (according as $\bar{\rho}$ is split or not); again we just do the third case, which is the most complicated. [Equation \(3\)](#) is equivalent to the equations

$$\begin{aligned} \mathcal{C}(\bar{\rho}, \tau_{\zeta,s}) &= \mathcal{C}(\bar{\rho}, \mathbb{1}) &&= [\mathfrak{a}_{nr}], \\ \mathcal{C}(\bar{\rho}, \tau_{\zeta,ns}) &= \mathcal{C}(\bar{\rho}, \text{St}) &&= [\mathfrak{a}_{nr}] + [\mathfrak{a}_N], \\ \mathcal{C}(\bar{\rho}, \tau_{\zeta_1, \zeta_2}) &= \mathcal{C}(\bar{\rho}, \mathbb{1}) + \mathcal{C}(\bar{\rho}, \text{St}) &&= [\mathfrak{a}_{nr}] + [\mathfrak{a}_{nr}] + [\mathfrak{a}_N], \end{aligned}$$

and

$$\mathcal{C}(\bar{\rho}, \tau) = 0 \quad \text{if } \tau \notin \bigcup_{\zeta, \zeta_1, \zeta_2} \{\tau_{\zeta,s}, \tau_{\zeta,ns}, \tau_{\zeta_1, \zeta_2}\}.$$

But by [Proposition 5.8](#) parts 2 and 3 we have:

$$\begin{aligned} \mathcal{C}(\bar{\rho}, \tau_{\zeta,s}) &= Z^4(\bar{R}(\bar{\rho}, \tau_{\zeta,s})) &&= [\mathfrak{a}_{nr}], \\ \mathcal{C}(\bar{\rho}, \tau_{\zeta,ns}) &= Z^4(\bar{R}(\bar{\rho}, \tau_{\zeta,s})) + Z^4(\bar{R}(\bar{\rho}, \tau_{1,ns})) &&= [\mathfrak{a}_{nr}] + [\mathfrak{a}_N], \\ \mathcal{C}(\bar{\rho}, \tau_{\zeta_1,\zeta_2}) &= Z^4(\bar{R}(\bar{\rho}, \tau_{\zeta_1,\zeta_2})) &&= 2[\mathfrak{a}_{nr}] + [\mathfrak{a}_N], \end{aligned}$$

and

$$\mathcal{C}(\bar{\rho}, \tau) = 0 \quad \text{if } \tau \notin \bigcup_{\zeta, \zeta_1, \zeta_2} \{\tau_{\zeta,s}, \tau_{\zeta,ns}, \tau_{\zeta_1,\zeta_2}\},$$

as required. □

Remark 4.3. Although the definition of $\mathcal{C}(\bar{\rho}, \tau)$ may seem ad-hoc, it in fact has the following natural interpretation: it is the reduction modulo λ of the cycle in $\mathcal{Z}^4(R^\square(\bar{\rho}))$ obtained by taking the Zariski closure of the closed points $x \in \text{Spec } R^\square(\bar{\rho})[1/l]$ such that $\text{rec}^{-1}(\rho_x)|_K$ contains $\sigma(\tau)$.

Remark 4.4. We conjecture that [Theorem 4.2](#) remains true when $l = 2$.

5. Calculations

Let $\bar{\rho} : G_F \rightarrow GL_2(\mathbb{F})$ be a continuous representation. The aims of this section are to give explicit presentations for the rings $R^\square(\bar{\rho}, \tau)$ and to compute the cycles $Z(\bar{R}^\square(\bar{\rho}, \tau)) \in \mathcal{Z}^4(\text{Spec } \bar{R}^\square(\bar{\rho}))$. We continue to assume that E is sufficiently large, as defined at the start of the previous section.

5A. Simple cases. When $\bar{\rho}|_{\bar{\rho}_F}$ is not scalar, then [Lemma 2.3](#) allows us to determine the universal framed deformation rings. Recall that if $\bar{r} : I_F \rightarrow GL_2(\mathbb{F})$ is a representation that extends to G_F then we have defined the set $L(\bar{r})$ of types that lift \bar{r} .

Proposition 5.1. *If $\bar{\rho}|_{\bar{\rho}_F}$ is irreducible, then*

$$R^\square(\bar{\rho}) \cong \mathcal{O}[[X, Y, Z_1, Z_2, Z_3]] / ((1 + X)^{l^a} - 1).$$

The l^a irreducible components of $\text{Spec } R^\square(\bar{\rho})$ are precisely the $\text{Spec } R^\square(\bar{\rho}, \tau)$ for $\tau \in L(\bar{\rho}|_{I_F})$.

If $\bar{\rho}|_{\bar{\rho}_F}$ is a sum of distinct characters which extend to G_F , then

$$R^\square(\bar{\rho}) \cong \mathcal{O}[[X_1, X_2, Y_1, Y_2, Z_1, Z_2]] / ((1 + X_1)^{l^a} - 1, (1 + X_2)^{l^a} - 1).$$

The l^{2a} irreducible components of $\text{Spec } R^\square(\bar{\rho})$ are precisely the $\text{Spec } R^\square(\bar{\rho}, \tau)$ for $\tau \in L(\bar{\rho}|_{I_F})$.

If $\bar{\rho}|_{\bar{\rho}_F}$ is a sum of distinct characters which are conjugate by the nontrivial element of $G_L \setminus G_F$, then

$$R^\square(\bar{\rho}) \cong \mathcal{O}[[X, Y, Z_1, Z_2, Z_3]] / ((1 + X)^{l^b} - 1).$$

The l^b irreducible components of $\text{Spec } R^\square(\bar{\rho})$ are precisely the $\text{Spec } R^\square(\bar{\rho}, \tau)$ for $\tau \in L(\bar{\rho}|_{I_F})$.

Proof. This follows straightforwardly from [Lemma 2.3](#). Suppose first that $\bar{\rho}|_{\tilde{P}_F}$ is irreducible. Then there is a unique irreducible representation θ of \tilde{P}_F such that $\bar{\rho}_\theta$ (in the notation of [Lemma 2.3](#)) is nonzero. For that θ , $\bar{\rho}_\theta$ is an unramified one-dimensional representation of G_F . So by [Lemmas 2.3](#) and [2.5](#)

$$R^\square(\bar{\rho}) \cong R^\square(\bar{\rho}_\theta)[[Z_1, Z_2, Z_3]] \cong \mathcal{O}[[X, Y, Z_1, Z_2, Z_3]]/((1 + X)^{l^a} - 1).$$

We have $\rho^\square \cong \tilde{\theta} \otimes \chi^\square$ where χ^\square is the universal character $G_F \rightarrow R^\square(\bar{\rho}_\theta)^\times$.

Suppose now that $\bar{\rho}|_{\tilde{P}_F} = \theta_1 \oplus \theta_2$ for distinct characters θ_1 and θ_2 . Suppose first that the θ_i are not G_F -conjugate. As in [Lemma 2.3](#), we pick \mathcal{O} -characters $\tilde{\theta}_1$ and $\tilde{\theta}_2$ of G_F lifting and extending θ_1 and θ_2 . Then (in the notation of [Lemma 2.3](#)) $\bar{\rho}_{\theta_1}$ and $\bar{\rho}_{\theta_2}$ are both unramified characters. By [Lemmas 2.3](#) and [2.5](#)

$$\begin{aligned} R^\square(\bar{\rho}) &\cong (R^\square(\bar{\rho}_{\theta_1}) \hat{\otimes} R^\square(\bar{\rho}_{\theta_2}))[[Z_1, Z_2]] \\ &\cong \mathcal{O}[[X_1, X_2, Y_1, Y_2, Z_1, Z_2]]/((1 + X_1)^{l^a} - 1, (1 + X_2)^{l^a} - 1). \end{aligned}$$

We have

$$\rho^\square \cong \tilde{\theta}_1 \otimes \chi_1^\square \oplus \tilde{\theta}_2 \otimes \chi_2^\square,$$

where each χ_i^\square is the universal character over $R^\square(\bar{\rho}_{\theta_i})$.

Suppose finally that θ_1 and θ_2 are G_F -conjugate. We take $\theta = \theta_1$; then $G_\theta = G_L$ where L is a quadratic extension of F . In fact, since $\tilde{P}_F \subset G_L$ and l is odd, we must have that G_L is the unramified quadratic extension of F . As in [Lemma 2.3](#), pick an \mathcal{O} -character $\tilde{\theta}$ of G_L lifting and extending θ . Then (in the notation of [Lemma 2.3](#)) $\bar{\rho}_\theta$ is an unramified character of G_L . By [Lemmas 2.3](#) and [2.5](#)

$$\begin{aligned} R^\square(\bar{\rho}) &\cong R^\square(\bar{\rho}_\theta)[[Z_1, Z_2, Z_3]] \\ &\cong \mathcal{O}[[X, Y, Z_1, Z_2, Z_3]]/((1 + X)^{l^b} - 1), \end{aligned}$$

since $v_l(q^2 - 1) = l^b$. We have

$$\rho^\square \cong \text{Ind}_{G_L}^{G_F}(\tilde{\theta} \otimes \chi^\square),$$

where χ^\square is the universal character over $R^\square(\bar{\rho}_\theta)$.

We show that $f : \text{Spec}(R^\square(\bar{\rho}, \tau)) \mapsto \tau$ is a bijection from the set of irreducible components of $\text{Spec}(R^\square(\bar{\rho}))$ to $L(\bar{\rho}|_{I_F})$. It is easy to see that f is an injection (from our explicit expressions for ρ^\square). The type of the \bar{E} -points of $\text{Spec}(R^\square(\bar{\rho}, \tau))$ is constant on irreducible components, so to show that a particular τ is in the image of f it suffices to produce a lift of $\bar{\rho}$ to \bar{E} of type τ . Each $\tau \in L(\bar{\rho}|_{I_F})$ is, by definition, the type of a lift of some $\bar{\rho}'$ with $\bar{\rho}'|_{I_F} \cong \bar{\rho}|_{I_F}$. But it is clear from the

calculations above that the image of f only depends on $\bar{\rho}|_{I_F}$, and so f is surjective as required. \square

Corollary 5.2. *If $\bar{\rho}|_{\tilde{P}_F}$ is not scalar, then $\bar{R}^\square(\bar{\rho})$ has a unique minimal prime \mathfrak{a} , which has dimension 4. For τ an inertial type we have that*

$$Z^4(\bar{R}^\square(\bar{\rho}, \tau)) = [\mathfrak{a}]$$

if $\tau \in L(\bar{\rho}|_{\tilde{P}_F})$ and $Z^4(\bar{R}^\square(\bar{\rho}, \tau)) = 0$ otherwise.

We may now assume that $\bar{\rho}|_{\tilde{P}_F}$ is scalar; after a twist (invoking [Clozel et al. 2008, Lemma 2.4.11] to extend the character occurring in $\bar{\rho}|_{\tilde{P}_F}$ to the whole Galois group), we may assume that $\bar{\rho}|_{\tilde{P}_F}$ is trivial, so that any lift of $\bar{\rho}|_{\tilde{P}_F}$ is also trivial. In this case, then, $\bar{\rho}|_{I_F}$ is inflated from a representation of the (pro)cyclic pro- l group I_F/\tilde{P}_F over a field of characteristic l . Any irreducible representation in characteristic l of an l -group is trivial, and so $\bar{\rho}|_{I_F}$ must be an extension of the trivial representation by the trivial representation. Now, because $\phi\sigma\phi^{-1} = \sigma^q$, $\bar{\rho}(\phi)$ maps the subspace of fixed vectors of $\bar{\rho}(\sigma)$ to itself; therefore, $\bar{\rho}$ must be an extension of unramified characters. That is, there is a short exact sequence

$$0 \rightarrow \chi_1 \rightarrow \bar{\rho} \rightarrow \chi_2 \rightarrow 0$$

for unramified characters χ_1 and χ_2 . Such an extension corresponds to an element of $H^1(G_F, \chi_1\chi_2^{-1})$; by a simple calculation with the local Euler characteristic formula and local Tate duality, this cohomology group is nonzero if and only if $\chi_1 = \chi_2$ or $\chi_1 = \chi_2\epsilon$. So we can easily deal with the case where neither of these two possibilities can occur.

Proposition 5.3. *Suppose that $\bar{\rho}|_{\tilde{P}_F}$ is trivial and that $\bar{\rho}(\phi)$ has eigenvalues $\bar{\alpha}, \bar{\beta} \in \mathbb{F}$ with $\bar{\alpha}/\bar{\beta} \notin \{1, q, q^{-1}\}$. Then*

$$R^\square(\bar{\rho}) \cong \frac{\mathcal{O}[[A, B, P, Q, X, Y]]}{((1 + P)^{l^a} - 1, (1 + Q)^{l^a} - 1)},$$

and $\rho^\square(\sigma)$ is diagonalizable with eigenvalues $1 + P$ and $1 + Q$.

For ζ an l^a -th root of unity (possibly equal to 1), we have that

$$\begin{aligned} R^\square(\bar{\rho}, \tau_{\zeta, s}) &= \mathcal{O}[[A, B, P, Q, X, Y]] / (1 + P - \zeta, 1 + Q - \zeta) \\ &\cong \mathcal{O}[[A, B, X, Y]] \end{aligned}$$

is formally smooth of relative dimension 4 over \mathcal{O} and that $R^\square(\bar{\rho}, \tau_{\zeta, ns}) = 0$. If $q \equiv 1 \pmod{l}$ and ζ_1, ζ_2 are distinct l^a -th roots of unity, then

$$\begin{aligned} R^\square(\bar{\rho}, \tau_{\zeta_1, \zeta_2}) &= \frac{\mathcal{O}[[A, B, P, Q, X, Y]]}{(2 + P + Q - \zeta_1 - \zeta_2, PQ - (\zeta_1 - 1)(\zeta_2 - 1))} \\ &\cong \mathcal{O}[[A, B, P, X, Y]] / (1 + P - \zeta_1)(1 + P - \zeta_2). \end{aligned}$$

For all other τ , $R^\square(\bar{\rho}, \tau) = 0$.

The ideal \mathfrak{a}_{nr} defining $\bar{R}^\square(\bar{\rho}, \tau_{1,s})$ is the unique minimal prime of $\bar{R}^\square(\bar{\rho})$. We have

$$Z^4(\bar{R}^\square(\bar{\rho}, \tau)) = \begin{cases} [\mathfrak{a}_{nr}] & \text{if } \tau = \tau_{\zeta,s}, \\ 2[\mathfrak{a}_{nr}] & \text{if } \tau = \tau_{\zeta_1,\zeta_2}, \\ 0 & \text{if } \tau = \tau_{\zeta,ns}. \end{cases}$$

Proof. First note that, by the above cohomology calculation, $\bar{\rho}(\sigma)$ must be trivial.

Let α and β be lifts of $\bar{\alpha}$ and $\bar{\beta}$ to \mathcal{O} . Suppose that \mathcal{A} is an object of $\mathcal{C}_{\mathcal{O}}$ and that M is a free \mathcal{A} -module of rank 2 with a continuous action of G_F given by $\rho : G_F \rightarrow \text{Aut}_{\mathcal{A}}(M)$, reducing to $\bar{\rho}$ modulo $\mathfrak{m}_{\mathcal{A}}$. Suppose that the characteristic polynomial of $\rho(\phi)$ is $(X - \alpha - A)(X - \beta - B)$, where $A, B \in \mathfrak{m}_{\mathcal{A}}$ —note that by Hensel’s lemma the characteristic polynomial *does* have roots in \mathcal{A} reducing to $\bar{\alpha}$ and $\bar{\beta}$. Then there is a decomposition

$$M = (\rho(\phi) - \alpha - A)M \oplus (\rho(\phi) - \beta - B)M.$$

Here it is crucial that $\alpha + A, \beta + B$ and, $\alpha - \beta + A - B$ are all invertible in \mathcal{A} . If $\bar{v}_\alpha, \bar{v}_\beta$ is a basis of eigenvectors of $\bar{\rho}(\phi)$ in $M \otimes \mathbb{F}$ and v_α, v_β is a basis of M lifting $\bar{v}_\alpha, \bar{v}_\beta$ then there are unique $X, Y \in \mathfrak{m}_{\mathcal{A}}$ such that $v_\alpha + Xv_\beta, v_\beta + Yv_\alpha$ are eigenvectors of $\rho(\phi)$. Moreover, replacing (v_α, v_β) by $(\mu v_\alpha, \mu v_\beta)$ for $\mu \in 1 + \mathfrak{m}_{\mathcal{A}}$ does not change X and Y .

Therefore we may assume that $\bar{\rho}(\phi) = \begin{pmatrix} \bar{\alpha} & 0 \\ 0 & \bar{\beta} \end{pmatrix}$ and that

$$\begin{aligned} \rho(\phi) &= \begin{pmatrix} 1 & X \\ Y & 1 \end{pmatrix}^{-1} \begin{pmatrix} \alpha + A & 0 \\ 0 & \beta + B \end{pmatrix} \begin{pmatrix} 1 & X \\ Y & 1 \end{pmatrix}, \\ \rho(\sigma) &= \begin{pmatrix} 1 & X \\ Y & 1 \end{pmatrix}^{-1} \begin{pmatrix} 1 + P & R \\ S & 1 + Q \end{pmatrix} \begin{pmatrix} 1 & X \\ Y & 1 \end{pmatrix}, \end{aligned}$$

where ρ determines $X, Y, P, R, S, Q \in \mathfrak{m}_{\mathcal{A}}$ uniquely. The equation $\phi\sigma\phi^{-1} = \sigma^q$ implies that

$$\begin{pmatrix} \alpha + A & 0 \\ 0 & \beta + B \end{pmatrix} \begin{pmatrix} 1 + P & R \\ S & 1 + Q \end{pmatrix} \begin{pmatrix} \alpha + A & 0 \\ 0 & \beta + B \end{pmatrix}^{-1} = \begin{pmatrix} 1 + P & R \\ S & 1 + Q \end{pmatrix}^q.$$

Looking at the top right and bottom left entries gives that $R = S = 0$. Then looking at the diagonal entries gives that $(1 + P)^{q-1} = (1 + Q)^{q-1} = 1$, which is equivalent to $(1 + P)^{l^a} = (1 + Q)^{l^a} = 1$. Thus

$$R^\square(\bar{\rho}) \cong \frac{\mathcal{O}[[A, B, P, Q, X, Y]]}{((1 + P)^{l^a} - 1, (1 + Q)^{l^a} - 1)}.$$

The possible inertial types are $\tau_{\zeta,s}$ and τ_{ζ_1,ζ_2} ($\tau_{\zeta,ns}$ cannot occur since all lifts are diagonalisable). Clearly $R^\square(\bar{\rho}, \tau_{\zeta,s})$ is defined by the equations $1 + P =$

$1 + Q = \zeta$. The ring $R^\square(\bar{\rho}, \tau_{\zeta_1, \zeta_2})^\circ$ is cut out by the equations $2 + P + Q = \zeta_1 + \zeta_2$, $(1 + P)(1 + Q) = \zeta_1 \zeta_2$ and the redundant equations $(1 + P)^{l^a} = (1 + Q)^{l^a} = 1$. But

$$R^\square(\bar{\rho}, \tau_{\zeta_1, \zeta_2})^\circ \cong \mathcal{O}[[A, B, P, X, Y]]/((1 + P - \zeta_1)(1 + P - \zeta_2))$$

is reduced and λ -torsion free and so is equal to $R^\square(\bar{\rho}, \tau_{\zeta_1, \zeta_2})$.

For the reduction modulo λ , simply note that

$$\begin{aligned} \bar{R}^\square(\bar{\rho}) &= \mathbb{F}[[A, B, P, Q, X, Y]]/(P^{l^a}, Q^{l^a}), \\ \bar{R}^\square(\bar{\rho}, \tau_{\zeta, s}) &= \mathbb{F}[[A, B, P, Q, X, Y]]/(P, Q), \end{aligned}$$

and

$$\bar{R}^\square(\bar{\rho}, \tau_{\zeta_1, \zeta_2}) = \mathbb{F}[[A, B, P, Q, X, Y]]/(P^2, Q^2, P + Q).$$

So $\mathfrak{a}_{nr} = (P, Q)$ is the unique minimal prime of $\bar{R}^\square(\bar{\rho})$ and the multiplicities are as claimed. \square

We extract the first half of the proof of this proposition for future use:

Lemma 5.4. *If $\bar{\rho}(\phi)$ has distinct eigenvalues, we may assume that it is diagonal. In that case, there exists a unique matrix $\begin{pmatrix} 1 & X \\ Y & 1 \end{pmatrix} \in GL_2(R^\square(\bar{\rho}))$, reducing to the identity modulo the maximal ideal, such that $\rho^\square(\phi) = \begin{pmatrix} 1 & X \\ Y & 1 \end{pmatrix}^{-1} \Phi \begin{pmatrix} 1 & X \\ Y & 1 \end{pmatrix}$ for a diagonal matrix Φ .* \square

5B. $q \not\equiv \pm 1 \pmod{l}$. Suppose that $q \not\equiv \pm 1 \pmod{l}$. By Proposition 5.3, we have already dealt with the cases in which the eigenvalues of $\bar{\rho}(\phi)$ are not in the ratio 1 or $q^{\pm 1}$. All other cases are dealt with by the following (after twisting and conjugating $\bar{\rho}$). Note that, by Lemma 3.7, the only possible types when $\bar{\rho}|_{\tilde{F}_F}$ is trivial are $\tau_{1,s}$ and $\tau_{1,ns}$.

Proposition 5.5. *Suppose that $q \not\equiv \pm 1 \pmod{l}$, and that $\bar{\rho}|_{\tilde{F}_F}$ is trivial.*

- (1) *Suppose $\bar{\rho}(\sigma)$ is trivial, and $\bar{\rho}(\phi) = \begin{pmatrix} 1 & \bar{y} \\ 0 & 1 \end{pmatrix}$ for $\bar{y} \in \mathbb{F}$. Then $R^\square(\bar{\rho}, \tau_{1,s}) = R^\square(\bar{\rho})$ is formally smooth of relative dimension 4 over \mathcal{O} , while $R^\square(\bar{\rho}, \tau_{1,ns}) = 0$.*
- (2) *Suppose that $\bar{\rho}(\sigma) = \begin{pmatrix} 1 & \bar{x} \\ 0 & 1 \end{pmatrix}$ and $\bar{\rho}(\phi) = \begin{pmatrix} q & 0 \\ 0 & 1 \end{pmatrix}$.
 If $\bar{x} \neq 0$, then $R^\square(\bar{\rho}, \tau_{1,ns}) = R^\square(\bar{\rho})$ is formally smooth of relative dimension 4 over \mathcal{O} , while $R^\square(\bar{\rho}, \tau_{1,s}) = 0$.
 If $\bar{x} = 0$ then*

$$R^\square(\bar{\rho}) \cong \mathcal{O}[[X_1, \dots, X_5]]/(X_1 X_2).$$

The quotients by the two minimal primes are $R^\square(\bar{\rho}, \tau_{1,s})$ and $R^\square(\bar{\rho}, \tau_{1,ns})$, so that both are formally smooth of relative dimension 4 over \mathcal{O} . The minimal primes \mathfrak{a}_{nr} and \mathfrak{a}_N of $\bar{R}^\square(\bar{\rho})$ which respectively define $\bar{R}^\square(\bar{\rho}, \tau_{1,s})$ and $\bar{R}^\square(\bar{\rho}, \tau_{1,ns})$ are distinct.

Proof. For the first part, write

$$\rho^\square(\sigma) = \begin{pmatrix} 1+A & B \\ C & 1+D \end{pmatrix}, \quad \rho^\square(\phi) = \begin{pmatrix} 1+P & y+R \\ S & 1+Q \end{pmatrix},$$

where y is a lift of \bar{y} (taken to be zero if $\bar{y} = 0$) and $A, B, C, D, P, Q, R, S \in \mathfrak{m}$.

Let $I = (A, B, C, D)$. Considering the equation $\rho^\square(\phi)\rho^\square(\sigma) = \rho^\square(\sigma)^q\rho^\square(\phi)$ modulo the ideal $I\mathfrak{m}$ gives equations $Cy \equiv (q - 1)A$, $B + Dy \equiv qAy + qB$, $C \equiv qC$, and $(q - 1)D + qCy \equiv 0$, all modulo $I\mathfrak{m}$. As $q \not\equiv 1 \pmod{l}$ we find that $I = I\mathfrak{m}$. Therefore, by Nakayama’s lemma, $I = 0$ and ρ^\square is unramified. So $R^\square(\bar{\rho}) = R^\square(\bar{\rho}, \tau_{1,s}) \cong \mathcal{O}[[P, Q, R, S]]$ as claimed. Note that this proof is still valid if $q \equiv -1 \pmod{l}$.

The proof of the second part is similar. By Lemma 5.4, we may write

$$\rho^\square(\sigma) = \begin{pmatrix} 1 & X \\ Y & 1 \end{pmatrix}^{-1} \begin{pmatrix} 1+A & x+B \\ C & 1+D \end{pmatrix} \begin{pmatrix} 1 & X \\ Y & 1 \end{pmatrix},$$

$$\rho^\square(\phi) = \begin{pmatrix} 1 & X \\ Y & 1 \end{pmatrix}^{-1} \begin{pmatrix} q(1+P) & 0 \\ 0 & 1+Q \end{pmatrix} \begin{pmatrix} 1 & X \\ Y & 1 \end{pmatrix},$$

with x a lift of \bar{x} (taken to be zero if $\bar{x} = 0$) and $A, B, C, D, X, Y, P, Q \in \mathfrak{m}$.

Let $I = (A, C, D)$. Considering the relation $\phi\sigma\phi^{-1} = \sigma^q$ modulo $I\mathfrak{m}$ and applying Nakayama’s lemma as before now yields $A = C = D = 0$ (using that $q^2 \not\equiv 1 \pmod{l}$). The relation (not modulo any ideal) gives that $(x + B)(P - Q) = 0$, and it is easy to see if this equality holds then the given formulae for ρ^\square do indeed define a representation so that

$$R^\square(\bar{\rho}) = \frac{\mathcal{O}[[B, P, Q, X, Y]]}{((x + B)(P - Q))}.$$

If $\bar{x} \neq 0$ then this implies that $P = Q$. Then $R^\square(\bar{\rho}) = \mathcal{O}[[B, P, X, Y]]$. It is clear that $R^\square(\bar{\rho}) = R^\square(\bar{\rho}, \tau_{1,ns})$, and the proposition follows.

If $\bar{x} = 0$ then, writing $U = P - Q$, we have $R^\square(\bar{\rho}) = \mathcal{O}[[B, P, U, X, Y]]/(BU)$. In these coordinates, it is clear from the description of ρ^\square that

$$R^\square(\bar{\rho}, \tau_{1,s}) = R^\square(\bar{\rho})/(B) \quad \text{and} \quad R^\square(\bar{\rho}, \tau_{1,ns}) = R^\square(\bar{\rho})/(U).$$

The proposition follows. □

5C. $q \equiv -1 \pmod{l}$. Suppose that $q \equiv -1 \pmod{l}$. By Proposition 5.3 we have already dealt with the cases in which the eigenvalues of $\bar{\rho}(\phi)$ are not in the ratio 1 or -1 . All other cases are dealt with by the following result (after twisting and conjugating $\bar{\rho}$). By Lemma 3.7, the only possible types when $\bar{\rho}|_{\tilde{\rho}_F}$ is trivial are $\tau_{1,s}$, $\tau_{1,ns}$, and τ_ξ for ξ a nontrivial l^b -th root of unity.

Proposition 5.6. *Suppose that $q \equiv -1 \pmod{l}$ and that $\bar{\rho}|_{\tilde{\rho}_F}$ is trivial.*

(1) Suppose that $\bar{\rho}(\sigma) = \begin{pmatrix} 1 & 0 \\ 0 & 1 \end{pmatrix}$ and $\bar{\rho}(\phi) = \begin{pmatrix} 1 & \bar{y} \\ 0 & 1 \end{pmatrix}$ for $\bar{y} \in \mathbb{F}$. Then

$$R^\square(\bar{\rho}, \tau_{1,s}) = R^\square(\bar{\rho})$$

is formally smooth of relative dimension 4 over \mathcal{O} , while

$$R^\square(\bar{\rho}, \tau_{1,ns}) = R^\square(\bar{\rho}, \tau_\xi) = 0.$$

If \mathfrak{a}_{nr} is the unique minimal prime of $\bar{R}^\square(\bar{\rho})$, then we have

$$Z^4(\bar{R}^\square(\bar{\rho}, \tau)) = \begin{cases} [\mathfrak{a}_{nr}] & \text{if } \tau = \tau_{1,s}, \\ 0 & \text{if } \tau = \tau_{1,ns}, \\ 0 & \text{if } \tau = \tau_\xi. \end{cases}$$

(2) Suppose that $\bar{\rho}(\sigma) = \begin{pmatrix} 1 & \bar{x} \\ 0 & 1 \end{pmatrix}$ and $\bar{\rho}(\phi) = \begin{pmatrix} q & 0 \\ 0 & 1 \end{pmatrix}$ for $\bar{x} \in \mathbb{F}$.

(a) If $\bar{x} \neq 0$, then $R^\square(\bar{\rho}, \tau_{1,ns})$ and $R^\square(\bar{\rho}, \tau_\xi)$ are formally smooth of relative dimension 4 over \mathcal{O} , while $R^\square(\bar{\rho}, \tau_{1,s}) = 0$. If \mathfrak{a}_N is the prime ideal of $\bar{R}^\square(\bar{\rho})$ cutting out $\bar{R}^\square(\bar{\rho}, \tau_{1,ns})$ then we have

$$Z^4(\bar{R}^\square(\bar{\rho}, \tau)) = \begin{cases} 0 & \text{if } \tau = \tau_{1,s}, \\ [\mathfrak{a}_N] & \text{if } \tau = \tau_{1,ns}, \\ [\mathfrak{a}_N] & \text{if } \tau = \tau_\xi. \end{cases} \tag{4}$$

(b) If $\bar{x} = 0$, then $R^\square(\bar{\rho}, \tau_{1,s})$ is formally smooth of relative dimension 4 over \mathcal{O} and

$$R^\square(\bar{\rho}, \tau_{1,ns}) \cong \frac{\mathcal{O}[[X_1, \dots, X_6]]}{((X_1, X_3) \cap (X_2, X_3 - (q+1)))}$$

is a non-Cohen–Macaulay ring of relative dimension 4 over \mathcal{O} . Its spectrum is the scheme theoretic union of two formally smooth components that do not intersect in the generic fibre. Lastly,

$$R^\square(\bar{\rho}, \tau_\xi) \cong \frac{\mathcal{O}[[X_1, \dots, X_5]]}{(X_1 X_2 - (\xi - \xi^{-1})^2)}$$

is a complete intersection domain of relative dimension 4 over \mathcal{O} with formally smooth generic fibre. If \mathfrak{a}_{nr} is the prime of $\bar{R}^\square(\bar{\rho})$ corresponding to $\bar{R}^\square(\bar{\rho}, \tau_{1,s})$ and $\mathfrak{a}_N, \mathfrak{a}'_N$ are the prime ideals of $\bar{R}^\square(\bar{\rho})$ corresponding to the two minimal primes of $\bar{R}^\square(\bar{\rho}, \tau_{1,ns})$, then we have

$$Z^4(\bar{R}^\square(\bar{\rho}, \tau)) = \begin{cases} [\mathfrak{a}_{nr}] & \text{if } \tau = \tau_{1,s}. \\ [\mathfrak{a}_N] + [\mathfrak{a}'_N] & \text{if } \tau = \tau_{1,ns}, \\ [\mathfrak{a}_N] + [\mathfrak{a}'_N] & \text{if } \tau = \tau_\xi. \end{cases} \tag{5}$$

Proof. The proof of the first part is identical to that of [Proposition 5.5](#), part 1.

For the second part, by [Lemma 5.4](#) we may write

$$\rho^\square(\sigma) = \begin{pmatrix} 1 & X \\ Y & 1 \end{pmatrix} \begin{pmatrix} 1+A & x+B \\ C & 1+D \end{pmatrix} \begin{pmatrix} 1 & X \\ Y & 1 \end{pmatrix},$$

$$\rho^\square(\phi) = \begin{pmatrix} 1 & X \\ Y & 1 \end{pmatrix} \begin{pmatrix} -(1+P) & 0 \\ 0 & 1+Q \end{pmatrix} \begin{pmatrix} 1 & X \\ Y & 1 \end{pmatrix},$$

with x a lift of \bar{x} (taken to be zero if $\bar{x} = 0$) and $A, B, C, D, X, Y, P, Q \in \mathfrak{m}$.

Firstly, it is clear that $R^\square(\bar{\rho}, \tau_{1,s}) = 0$ if $\bar{x} \neq 0$ and, if $\bar{x} = 0$, that

$$R^\square(\bar{\rho}, \tau_{1,s}) \cong \mathcal{O}[[P, Q, X, Y]].$$

Next we deal with $\tau_{1,ns}$. On $R^\square(\bar{\rho}, \tau_{1,ns})$ we have the equations

$$\begin{aligned} \text{tr}(\rho^\square(\sigma)) &= 2, \\ \det(\rho^\square(\sigma)) &= 1, \\ q \text{tr}(\rho(\phi))^2 &= (q + 1)^2 \det(\rho(\phi)), \end{aligned}$$

and

$$\rho^\square(\phi)\rho^\square(\sigma)\rho^\square(\phi)^{-1} = \rho^\square(\sigma)^q.$$

The first two of these may be rewritten as

$$A = -D \quad \text{and} \quad A^2 + (x + B)(C) = 0$$

and the third can be written as

$$(q + 1 + P + qQ)(q + 1 + Q + qP) = 0.$$

By the Cayley–Hamilton theorem, $(\rho^\square(\sigma) - 1)^2 = 0$ on $R^\square(\bar{\rho}, \tau_{1,ns})^\circ$; it follows that $\rho^\square(\sigma)^q - 1 = q(\rho^\square(\sigma) - 1)$ on $R^\square(\bar{\rho}, \tau_{1,ns})^\circ$ and so the relation $\phi\sigma\phi^{-1} = \sigma^q$ together with $D = -A$ yields the equation

$$\begin{pmatrix} A & -(x+B)\frac{1+P}{1+Q} \\ -C\frac{1+Q}{1+P} & -A \end{pmatrix} = \begin{pmatrix} qA & q(x+B) \\ qC & -qA \end{pmatrix}.$$

Equating coefficients and using that 2 and $q - 1$ are invertible we obtain that $A = D = 0$ and that

$$(x + B)(q + 1 + qQ + P) = 0, \tag{6}$$

$$C(q + 1 + Q + qP) = 0, \tag{7}$$

$$(x + B)C = 0, \tag{8}$$

$$(q + 1 + Q + qP)(q + 1 + qQ + P) = 0 \tag{9}$$

is a complete set of equations cutting out $R^\square(\bar{\rho}, \tau_{1,ns})^\circ$ (the last two equations being, respectively, the conditions on $\det(\rho^\square(\sigma))$ and on $\rho^\square(\phi)$).

If $\bar{x} \neq 0$ then these equations are equivalent to $q + 1 + qQ + P = 0$ and $C = 0$ and so we see that

$$R^\square(\bar{\rho}, \tau_{1,ns}) \cong \mathcal{O}[[B, P, X, Y]].$$

If $\bar{x} = 0$ then the left hand sides of the four equations given generate the ideal

$$I = (B, q + 1 + Q + qP) \cap (C, q + 1 + qQ + P)$$

in $\mathcal{O}[[B, C, P, Q, X, Y]]$. Since $\mathcal{O}[[B, C, P, Q, X, Y]]/I$ is reduced and λ -torsion free and a Zariski dense set of its \bar{E} -points have type $\tau_{1,ns}$, it is equal to $R^\square(\bar{\rho}, \tau_{1,ns})$. After the change of variables

$$X_3 = \frac{q(q + 1 + Q + qP)}{(q - 1)(1 + P)}, \quad (X_1, X_2, X_4, X_5, X_6) = (B, C, P, X, Y)$$

we get the presentation given in the proposition.

Let

$$\mathcal{S} = \frac{\mathcal{O}[[X_1, X_2, X_3]]}{(X_1, X_3) \cap (X_2, X_3 - (q + 1))}.$$

Then \mathcal{S} has dimension two. We show that \mathcal{S} is not Cohen–Macaulay; the same is then true for $R^\square(\bar{\rho}, \tau_{1,ns})$. Now λ is a nonzerodivisor in \mathcal{S} , and

$$\mathcal{S}/\lambda = \frac{\mathbb{F}[[X_1, X_2, X_3]]}{(X_1X_2, X_1X_3, X_2X_3, X_3^2)}.$$

The maximal ideal of \mathcal{S}/λ is annihilated by X_3 , and $X_3 \neq 0$ in \mathcal{S}/λ . So \mathcal{S}/λ , and hence \mathcal{S} , is not Cohen–Macaulay. The remaining statements about $R^\square(\bar{\rho}, \tau_{1,ns})$ are clear.

Now suppose that $\tau = \tau_\xi$. On $R^\square(\bar{\rho}, \tau_\xi)$ we have

$$\begin{aligned} \text{tr}(\rho^\square(\sigma)) &= \xi + \xi^{-1}, \\ \det(\rho^\square(\sigma)) &= 1, \end{aligned}$$

and

$$\rho^\square(\phi)\rho^\square(\sigma)\rho^\square(\phi)^{-1} = \rho^\square(\sigma)^q.$$

The first two of these may be rewritten as

$$A + D = \xi + \xi^{-1} - 2 \quad \text{and} \quad AD - (x + B)C = 2 - \xi - \xi^{-1}.$$

By the Cayley–Hamilton theorem, $(\rho^\square(\sigma) - \xi)(\rho^\square(\sigma) - \xi^{-1}) = 0$. As

$$T^q \equiv \xi + \xi^{-1} - T \pmod{(T - \xi)(T - \xi^{-1})}$$

in $\mathbb{Z}[T]$, the relation $\phi\sigma\phi^{-1} = \sigma^q$ yields

$$\begin{pmatrix} 1+A & -(x+B)\frac{1+P}{1+Q} \\ -C\frac{1+Q}{1+P} & 1+D \end{pmatrix} = \begin{pmatrix} \xi + \xi^{-1} - 1 - A & -(x+B) \\ -C & \xi + \xi^{-1} - 1 - D \end{pmatrix}.$$

Equating coefficients and combining with the equation $\det(\rho^\square(\sigma)) = 1$ we get

$$A = D = \frac{\xi + \xi^{-1}}{2} - 1, \tag{10}$$

$$(x + B)(P - Q) = 0, \tag{11}$$

$$C(P - Q) = 0, \tag{12}$$

$$4(x + B)C = (\xi - \xi^{-1})^2. \tag{13}$$

If $\bar{x} \neq 0$ then these equations are equivalent to $P = Q$ and $C = (\xi - \xi^{-1})^2 / (4(x + B))$, so that

$$R^\square(\bar{\rho}, \tau_\xi) \cong \mathcal{O}[\![X, Y, B, P]\!].$$

If $\bar{x} = 0$, then the equations imply that

$$0 = BC(P - Q) = \left(\frac{\xi - \xi^{-1}}{2}\right)^2 (P - Q)$$

and hence that $P = Q$, as $R^\square(\bar{\rho}, \tau_\xi)$ is λ -torsion free by definition. Thus

$$R^\square(\bar{\rho}, \tau_\xi) \cong \frac{\mathcal{O}[\![X, Y, B, C, P]\!]}{(4BC - (\xi - \xi^{-1})^2)}.$$

The remaining statements about $R^\square(\bar{\rho}, \tau_\xi)$ are clear.

Now we calculate the various $Z^4(\bar{R}^\square(\bar{\rho}, \tau))$. For part 1, this is trivial. For part 2, we have computed each $\bar{R}^\square(\bar{\rho}, \tau)$ as a quotient of the ring $\mathbb{F}[\![A, B, C, D, P, Q, X, Y]\!]$ by an ideal which we call $I(\tau)$. We see that if $\bar{x} \neq 0$ then $I(\tau_{1,ns}) = I(\tau_\xi)$, and $\bar{R}^\square(\bar{\rho}, \tau_{1,s}) = 0$, from which (4) follows. If $\bar{x} = 0$ then

$$I(\tau_{1,s}) = (A, B, C, D),$$

$$I(\tau_{1,ns}) = (A, D, BC, B(Q - P), C(Q - P), (Q - P)^2),$$

and

$$I(\tau_\xi) = (A, D, BC, Q - P).$$

The minimal primes above these $I(\tau)$ in $\mathbb{F}[\![A, \dots, Y]\!]$ are $\mathfrak{a}_{nr} = (A, B, C, D)$, $\mathfrak{a}_N = (A, C, D, Q - P)$ and $\mathfrak{a}_{N'} = (A, B, D, Q - P)$; the multiplicities in (5) are then easily verified. □

Remark 5.7. When $\bar{\rho}$ is unramified and $\bar{\rho}(\phi) = \begin{pmatrix} q & 0 \\ 0 & 1 \end{pmatrix}$, the ring $R^\square(\bar{\rho}, \tau_{1,ns})$ is not Cohen–Macaulay. However the ring $R^\square(\bar{\rho}, \text{unip})$, which is defined to be the maximal reduced quotient of $R^\square(\bar{\rho})$ on which $\rho^\square(\sigma)$ is unipotent (so that $\text{Spec } R^\square(\bar{\rho}, \text{unip})$ is the scheme-theoretic union in $\text{Spec } R^\square(\bar{\rho})$ of $\text{Spec } R^\square(\bar{\rho}, \tau_{1,s})$ with $\text{Spec } R^\square(\bar{\rho}, \tau_{1,ns})$), is Cohen–Macaulay. Indeed it is easy to see from the proof that

$$R^\square(\bar{\rho}, \text{unip}) \cong \frac{\mathcal{O}[\![X_1, \dots, X_6]\!]}{(X_1X_2, X_1(X_3 - (q + 1)), X_2X_3)},$$

which is Cohen–Macaulay ($(\lambda, X_1 + X_2 + X_3, X_4, X_5, X_6)$ is a regular sequence).

5D. $q \equiv 1 \pmod{l}$. Suppose that $q \equiv 1 \pmod{l}$. By [Proposition 5.3](#) we have already dealt with the cases in which the eigenvalues of $\bar{\rho}(\phi)$ are distinct. All other cases are dealt with by the following (after twisting and conjugating $\bar{\rho}$). Note that by [Lemma 3.7](#), the only possible types when $\bar{\rho}|_{\bar{\rho}_F}$ is trivial are $\tau_{\zeta,s}$, $\tau_{\zeta,ns}$ and τ_{ζ_1,ζ_2} for ζ any l^a -th root of unity and ζ_1, ζ_2 any distinct l^a -th roots of unity.

Proposition 5.8. *Suppose that $q \equiv 1 \pmod{l}$ and that $\bar{\rho}|_{\bar{\rho}_F}$ is trivial. Suppose that $\bar{\rho}(\sigma) = \begin{pmatrix} 1 & \bar{x} \\ 0 & 1 \end{pmatrix}$ and $\bar{\rho}(\phi) = \begin{pmatrix} 1 & \bar{y} \\ 0 & 1 \end{pmatrix}$ for $\bar{x}, \bar{y} \in \mathbb{F}$.*

(1) *If $\bar{x} \neq 0$ then $R^\square(\bar{\rho}, \tau_{\zeta,s}) = 0$, while $R^\square(\bar{\rho}, \tau_{\zeta,ns})$ and $R^\square(\bar{\rho}, \tau_{\zeta_1,\zeta_2})$ are formally smooth over \mathcal{O} of relative dimension 4.*

If \mathfrak{a}_N is the four-dimensional prime of $\bar{R}^\square(\bar{\rho})$ corresponding to $\bar{R}^\square(\bar{\rho}, \tau_{1,ns})$ then we have

$$Z^4(\bar{R}^\square(\bar{\rho}, \tau)) = \begin{cases} 0 & \text{if } \tau = \tau_{\zeta,s}, \\ [\mathfrak{a}_N] & \text{if } \tau = \tau_{\zeta,ns}, \\ [\mathfrak{a}_N] & \text{if } \tau = \tau_{\zeta_1,\zeta_2}. \end{cases} \quad (14)$$

(2) *If $\bar{x} = 0$ and $\bar{y} \neq 0$, then $R^\square(\bar{\rho}, \tau_{\zeta,s})$ and $R^\square(\bar{\rho}, \tau_{\zeta,ns})$ are formally smooth over \mathcal{O} of relative dimension 4 while*

$$R^\square(\bar{\rho}, \tau_{\zeta_1,\zeta_2}) \cong \mathcal{O}[[X_1, \dots, X_5]]/(X_1^2 X_2 - (\zeta_1 - \zeta_2)^2)$$

is a complete intersection domain of relative dimension 4 over \mathcal{O} .

If \mathfrak{a}_{nr} and \mathfrak{a}_N are the prime ideals of $\bar{R}^\square(\bar{\rho})$ corresponding to $\bar{R}^\square(\bar{\rho}, \tau_{1,s})$ and $\bar{R}^\square(\bar{\rho}, \tau_{1,ns})$ respectively, then

$$Z^4(\bar{R}^\square(\bar{\rho}, \tau)) = \begin{cases} [\mathfrak{a}_{nr}] & \text{if } \tau = \tau_{\zeta,s}, \\ [\mathfrak{a}_N] & \text{if } \tau = \tau_{\zeta,ns}, \\ 2[\mathfrak{a}_{nr}] + [\mathfrak{a}_N] & \text{if } \tau = \tau_{\zeta_1,\zeta_2}. \end{cases} \quad (15)$$

(3) *If $\bar{x} = \bar{y} = 0$, then $R^\square(\bar{\rho}, \tau_{\zeta,s})$ is formally smooth over \mathcal{O} of relative dimension 4 while $R^\square(\bar{\rho}, \tau_{\zeta,ns})$ and $R^\square(\bar{\rho}, \tau_{\zeta_1,\zeta_2})$ are non-Gorenstein Cohen–Macaulay domains of relative dimension 4 over \mathcal{O} .*

Both $\bar{R}^\square(\bar{\rho}, \tau_{\zeta,s})$ and $\bar{R}^\square(\bar{\rho}, \tau_{\zeta,ns})$ are domains; let the corresponding primes of $\bar{R}^\square(\bar{\rho})$ be \mathfrak{a}_{nr} and \mathfrak{a}_N respectively. Then

$$Z^4(\bar{R}^\square(\bar{\rho}, \tau)) = \begin{cases} [\mathfrak{a}_{nr}] & \text{if } \tau = \tau_{\zeta,s}, \\ [\mathfrak{a}_N] & \text{if } \tau = \tau_{\zeta,ns}, \\ 2[\mathfrak{a}_{nr}] + [\mathfrak{a}_N] & \text{if } \tau = \tau_{\zeta_1,\zeta_2}. \end{cases} \quad (16)$$

Proof. Write

$$\rho^\square(\sigma) = \begin{pmatrix} 1+A & x+B \\ C & 1+D \end{pmatrix}, \quad \rho^\square(\phi) = \begin{pmatrix} 1+P & y+R \\ S & 1+Q \end{pmatrix}$$

with $A, B, C, D, P, Q, R,$ and $S \in \mathfrak{m}$ and x, y lifts of \bar{x}, \bar{y} (taken to be zero if \bar{x} or $\bar{y} = 0$).

First, we have that $R^\square(\bar{\rho}, \tau_{\zeta,s}) = 0$ if $\bar{x} \neq 0$ and

$$R^\square(\bar{\rho}, \tau_{\zeta,s}) \cong \mathcal{O}[[P, Q, R, S]]$$

otherwise.

Next, we look at $R^\square(\bar{\rho}, \tau_{\zeta_1, \zeta_2})$ for ζ_1 and ζ_2 distinct l^a -th roots of unity. The condition that $\rho^\square(\sigma)$ has characteristic polynomial $(t - \zeta_1)(t - \zeta_2)$ is equivalent to the equations

$$A + D = \zeta_1 + \zeta_2 - 2 \quad \text{and} \quad AD - (x + B)C = (\zeta_1 - 1)(\zeta_2 - 1).$$

Since $(t - \zeta_1)(t - \zeta_2) \mid t^{q-1} - 1$, by the Cayley–Hamilton theorem we have

$$\rho^\square(\sigma)^q = \rho^\square(\sigma)$$

on $R^\square(\bar{\rho}, \tau_{\zeta_1, \zeta_2})^\circ$. So the relation $\phi\sigma\phi^{-1} = \sigma^q$ yields

$$\begin{pmatrix} 1+A & x+B \\ C & 1+D \end{pmatrix} \begin{pmatrix} 1+P & y+R \\ S & 1+Q \end{pmatrix} = \begin{pmatrix} 1+P & y+R \\ S & 1+Q \end{pmatrix} \begin{pmatrix} 1+A & x+B \\ C & 1+D \end{pmatrix}.$$

Equating coefficients, eliminating D and writing $U = P - Q$ and $F = A - D = 2A - (\zeta_1 + \zeta_2 - 2)$ we see that $R^\square(\bar{\rho}, \tau_{\zeta_1, \zeta_2})$ is the reduced, l -torsion-free quotient of $\mathcal{O}[[B, C, F, P, R, S, U]]$ by the relations

$$(x + B)S = (y + R)C, \tag{17}$$

$$F(y + R) = U(x + B), \tag{18}$$

$$FS = UC, \tag{19}$$

$$(\zeta_1 - \zeta_2)^2 = F^2 + 4(x + B)C. \tag{20}$$

If $\bar{x} \neq 0$ then these equations are equivalent to $U = F(y + R)(x + B)^{-1}$, $C = \frac{1}{4}((\zeta_1 - \zeta_2)^2 - F^2)(x + B)^{-1}$, and $S = C(y + R)(x + B)^{-1}$ so that

$$R^\square(\bar{\rho}, \tau_{\zeta_1, \zeta_2}) \cong \mathcal{O}[[B, F, P, R]].$$

If $\bar{x} = 0$ and $\bar{y} \neq 0$, then $F = BU(y + R)^{-1}$ and $C = BS(y + R)^{-1}$ will be a solution to equations (17)–(20) provided that

$$(\zeta_1 - \zeta_2)^2 = \left(\frac{B}{y + R}\right)^2 (U^2 + 4(y + R)S).$$

Writing $(X_1, \dots, X_5) = (B(y + R)^{-1}, U^2 + 4(y + R)S, P, R, U)$ we get

$$R^\square(\bar{\rho}, \tau_{\zeta_1, \zeta_2}) \cong \frac{\mathcal{O}[[X_1, \dots, X_5]]}{X_1^2 X_2 - (\zeta_1 - \zeta_2)^2}$$

as claimed. The other statements about $R^\square(\bar{\rho}, \tau_{\zeta_1, \zeta_2})$ follow easily.

If $\bar{x} = \bar{y} = 0$, then let $\mathcal{A} = \mathcal{O}[[B, C, F, P, R, S, U]]$ and $I \triangleleft \mathcal{A}$ be the ideal

$$I = ((\zeta_1 - \zeta_2)^2 - F^2 - 4BC, BS - CR, FR - BU, FS - CU).$$

Note that the ideal

$$J = (BS - CR, FR - BU, FS - CU)$$

is generated by the 2×2 minors of $\begin{pmatrix} B & C & F \\ R & S & U \end{pmatrix}$. So, by [Proposition 2.7](#), \mathcal{A}/J is a Cohen–Macaulay, non-Gorenstein domain. Since $F^2 - 4BC$ is not zero in the domain $\mathcal{A}/J \otimes \mathbb{F}$, $(\lambda, F^2 - 4BC)$ is a regular sequence in \mathcal{A}/J . Hence $(F^2 - 4BC - (\zeta_1 - \zeta_2)^2, \lambda)$ is a regular sequence in \mathcal{A}/J , and therefore \mathcal{A}/I is \mathcal{O} -flat, Cohen–Macaulay and non-Gorenstein. It is reduced because it is Cohen–Macaulay and, as we shall show in the next paragraph, generically reduced.

To show that \mathcal{A}/I is irreducible, it suffices to show that $\mathcal{X} = \text{Spec}(\mathcal{A}/I \otimes E)$ is irreducible. This follows if we can show that \mathcal{X} is formally smooth and connected. As $F^2 - 4BC \neq 0$ on \mathcal{X} , it is covered by the affine open subsets $\mathcal{U}_B = \{B \neq 0\}$ and $\mathcal{U}_F = \{F \neq 0\}$. By the argument used in the $\bar{x} \neq 0$ case, \mathcal{U}_B is formally smooth. A similar argument works for \mathcal{U}_F , the projection map

$$p : \mathcal{X} \rightarrow \text{Spec}\left(\frac{\mathcal{O}[[F, B, C, U, P]]}{(F^2 + 4BC - (\zeta_1 - \zeta_2)^2)} \otimes E\right)$$

is an isomorphism from \mathcal{U}_F onto an open subscheme, but the right hand side is easily seen to be formally smooth. Hence \mathcal{X} is formally smooth. Note that the composition of the map p with the projection away from U is a continuous map with connected fibres and connected image, which admits a continuous section (obtained by taking $R = S = U = 0$); it follows that \mathcal{X} is connected, as required. Since \mathcal{X} is formally smooth it is certainly reduced; therefore \mathcal{A}/I is generically reduced (as it is \mathcal{O} -flat), just as we claimed above.

Now we turn to $R^\square(\bar{\rho}, \tau_{\zeta, ns})$. By [Lemma 2.4](#) we may assume that $\zeta = 1$. The condition that the characteristic polynomial of $\rho^\square(\sigma)$ be $(t - 1)^2$ is equivalent to the equations

$$A + D = 0 \quad \text{and} \quad AD - (x + B)C = 0.$$

Writing $T = P + Q$ and $U = P - Q$ the condition that

$$q \text{tr}(\rho^\square(\phi))^2 = (q + 1)^2 \det(\rho^\square(\phi))$$

becomes

$$(q - 1)^2(T + 2)^2 = (q + 1)^2(U^2 + 4(y + R)S).$$

Since $t^q - 1 \equiv q(t - 1) \pmod{(t - 1)^2}$, the Cayley–Hamilton theorem shows that

$$\rho^\square(\sigma)^q - 1 = q(\rho^\square(\sigma) - 1)$$

on $R^\square(\bar{\rho}, \tau_{1,ns})$. From $\phi\sigma\phi^{-1} = \sigma^q$ we therefore get the equation

$$(\phi - 1)(\sigma - 1) - (\sigma - 1)(\phi - 1) = (q - 1)(\sigma - 1)\phi$$

on $R^\square(\bar{\rho}, \tau_{1,ns})$. Equating coefficients and substituting $D = -A$ we get the equations

$$A^2 + (x + B)C = 0, \tag{21}$$

$$(q - 1)^2(T + 2)^2 = (q + 1)^2(U^2 + 4(y + R)S), \tag{22}$$

$$C(y + R) - S(x + B) = (q - 1)(A(1 + P) + (x + B)S), \tag{23}$$

$$U(x + B) - 2A(y + R) = (q - 1)(A(y + R) + (x + B)(1 + Q)), \tag{24}$$

$$2AS - CU = (q - 1)(C(1 + P) - AS), \tag{25}$$

$$S(x + B) - C(y + R) = (q - 1)(C(y + R) - A(1 + Q)). \tag{26}$$

After replacing P with $(T + U)/2$ and Q with $(T - U)/2$, this is a complete set of equations for $R^\square(\bar{\rho}, \tau_{1,ns})$ in $\mathcal{O}[[A, B, C, R, S, T, U]]$.

We replace equations (23) and (26) by their sum and difference

$$(q - 1)(AU + (x + B)S + C(y + R)) = 0, \tag{27}$$

$$(q + 1)(C(y + R) - (x + B)S) = (q - 1)A(2 + T). \tag{28}$$

As $R^\square(\bar{\rho}, \tau_{1,ns})$ is λ -torsion free, (27) implies that

$$AU + (x + B)S + C(y + R) = 0. \tag{29}$$

We could also write this equation as $\text{tr}((\sigma - 1)\phi) = 0$.

Putting $\alpha(T) = ((q - 1)(2 + T))/(q + 1)$, we find that (21), (22), (24), (25) and (28)+(29) may respectively be rewritten as

$$\begin{aligned} A^2 + (x + B)C &= 0, \\ 4(y + R)S + (U - \alpha(T))(U + \alpha(T)) &= 0, \\ 2A(y + R) - (x + B)(U - \alpha(T)) &= 0, \\ 2AS - C(U + \alpha(T)) &= 0, \\ 2C(y + R) + A(U - \alpha(T)) &= 0, \\ 2(x + B)S + A(U + \alpha(T)) &= 0. \end{aligned}$$

Let I be the ideal of $\mathcal{O}[[A, B, C, R, S, T, U]]$ generated by these equations and let $R' = \mathcal{O}[[A, B, C, R, S, T, U]]/I$, so that $R^\square(\bar{\rho}, \tau_{1,ns})$ is the maximal reduced l -torsion free quotient of R' .

If $\bar{x} \neq 0$ then C , U , and S are uniquely determined by A , B , R , and T so that

$$R^\square(\bar{\rho}, \tau_{1,ns}) \cong \mathcal{O}[[A, B, R, T]].$$

If $\bar{y} \neq 0$, then S , C , and A are uniquely determined by B , R , T , and U so that

$$R^\square(\bar{\rho}, \tau_{1,ns}) \cong \mathcal{O}[[B, R, T, U]].$$

If $\bar{x} = \bar{y} = 0$, so that $x = y = 0$, observe that

$$R' \cong \frac{\mathcal{B}}{J_0 + J_1},$$

where

$$\mathcal{B} = \mathcal{O}[[X_1, \dots, X_4, Y_1, \dots, Y_4, T]],$$

the ideal J_0 is generated by the 2×2 minors of

$$\begin{pmatrix} X_1 & X_2 & X_3 & X_4 \\ Y_1 & Y_2 & Y_3 & Y_4 \end{pmatrix}$$

and $J_1 = (X_1 + Y_2, X_3 - Y_4 + 2(q-1)/(q+1))$. (The change of variables is $X_1 = A$, $X_2 = B$, $Y_1 = C$, $Y_2 = -A$, $X_3 = -2R/(2+T)$, $Y_4 = 2S(2+T)$, $Y_3 = (U - \alpha(T))/(2+T)$, and $X_4 = (U + \alpha(T))/(2+T)$.) Then, by [Proposition 2.7](#), \mathcal{B}/J_0 is a Cohen–Macaulay non-Gorenstein domain. Moreover, $(\lambda, X_1 + Y_2, X_3 - Y_4)$ may be checked to be a regular sequence on \mathcal{B}/J_0 . Therefore $(X_1 + Y_2, X_3 + Y_4 + 2(q-1)/(q+1), \lambda)$ is also regular, and so $\mathcal{B}/(J_0 + J_1)$ is Cohen–Macaulay, \mathcal{O} -flat, and not Gorenstein. The same is then true for R' .

We show that $R' \otimes \mathbb{F}$ is a domain, which implies that R' is a domain. Let \bar{I} be the image of I in $\mathbb{F}[[A, B, C, R, S, T, U]]$. Then \bar{I} is homogeneous so $\text{gr}(R' \otimes \mathbb{F}) = \mathbb{F}[A, B, C, R, S, T, U]/\bar{I}$ and it suffices to check that this is a domain (by [Eisenbud 1995](#), Corollary 5.5). It is therefore sufficient to check that $\text{Proj}(\text{gr}(R' \otimes \mathbb{F}))$ is reduced and irreducible. But it is easy to check this on the usual seven affine pieces. This argument is from [Taylor 2009](#).

Next we show that $R^\square(\bar{\rho}, \tau_{1,ns})$ is reduced. In fact, we show that

$$\mathcal{Y} = \text{Spec}(R^\square(\bar{\rho}, \tau_{1,ns}) \otimes E)$$

is formally smooth, which implies that $R^\square(\bar{\rho}, \tau_{1,ns})$ is reduced because it is Cohen–Macaulay and \mathcal{O} -flat. For $\star = B, C, R, S, U - \alpha(T)$, or $U + \alpha(T)$ let $\mathcal{U}_\star = \{\star \neq 0\} \subset \mathcal{Y}$ be the corresponding affine open subscheme. Then the \mathcal{U}_\star are an affine open cover of \mathcal{Y} . For $\star = B, C, R$ or S we see that \mathcal{U}_\star is formally smooth by the same argument as for the cases $\bar{x} \neq 0$ and $\bar{y} \neq 0$ above. For $\mathcal{U}_{U \pm \alpha(T)}$, the projection morphism

$$p : \mathcal{U}_{U - \alpha(T)} \rightarrow \text{Spec}\left(\frac{\mathcal{O}[[C, R, S, T]]}{4RS - (U + \alpha(T))(U - \alpha(T))} \otimes E\right)$$

is an isomorphism onto an open subscheme. But the right hand scheme is easily seen to be formally smooth as required.

Finally we calculate the $Z^4(\bar{R}(\bar{\rho}, \tau))$. We do this when $\bar{x} = \bar{y} = 0$, as the other cases are similar but easier. We have written each $\bar{R}^\square(\bar{\rho}, \tau)$ as the quotient of $\mathbb{F}\llbracket A, B, C, R, S, T, U \rrbracket$ by an ideal which we call $I(\tau)$. Recall the presentations

$$\begin{aligned} I(\tau_{\zeta,s}) &= (A, B, C), \\ I(\tau_{\zeta,ns}) &= (A^2 + BC, 4RS + U^2, 2CR + AU, 2BS + AU, 2AR - BU, 2AS - CU), \\ I(\tau_{\zeta_1, \zeta_2}) &= (A^2 + BC, BS - CR, 2AR - BU, 2AS - CU) \end{aligned}$$

(using that $A + D = 0$ in $\bar{R}^\square(\bar{\rho}, \tau)$ for each τ , we have eliminated D and written $F = A - D = 2A$). We have already shown that $I(\tau_{\zeta,s})$ and $I(\tau_{\zeta,ns})$ are prime — they are the ideals denoted \mathfrak{a}_{nr} and \mathfrak{a}_N in the statement of the theorem. It is clear that

$$Z^4(\bar{R}^\square(\bar{\rho}, \tau_{\zeta,s})) = [\mathfrak{a}_{nr}], \quad Z^4(\bar{R}^\square(\bar{\rho}, \tau_{\zeta,ns})) = [\mathfrak{a}_N].$$

Suppose that \mathfrak{p} is a prime ideal of $\mathbb{F}\llbracket A, B, C, R, S, T, U \rrbracket$ containing $I(\tau_{\zeta_1, \zeta_2})$. We show that \mathfrak{p} contains \mathfrak{a}_{nr} or \mathfrak{a}_N . If $B, C \in \mathfrak{p}$ then $A \in \mathfrak{p}$ as $A^2 + BC \in I(\tau_{\zeta_1, \zeta_2})$ and we have $\mathfrak{a}_{nr} \subset \mathfrak{p}$. Otherwise, suppose that $B \notin \mathfrak{p}$. As $A^2 + BC \in \mathfrak{p}$, either both A and C are in \mathfrak{p} or neither is. If $A, C \in \mathfrak{p}$ then from $2AR - BU \in \mathfrak{p}$ we deduce that $U \in \mathfrak{p}$, while from $BS - CR \in \mathfrak{p}$ we deduce that $S \in \mathfrak{p}$. It is then easy to see that $\mathfrak{a}_N \subset \mathfrak{p}$. If $A, B, C \notin \mathfrak{p}$ then because $B(2CR + AU)$ and $C(2BS + AU)$ are in $I(\tau_{\zeta_1, \zeta_2})$ we see that $2CR + AU, 2BS + AU \in \mathfrak{p}$. This implies that $A(4RS + U^2) \in \mathfrak{p}$, and so $4RS + U^2 \in \mathfrak{p}$ and hence $\mathfrak{a}_N \subset \mathfrak{p}$ as required.

To finish, it is easy to check that

$$e(\bar{R}^\square(\bar{\rho}, \tau_{\zeta_1, \zeta_2}), \mathfrak{a}_{nr}) = 2 \quad \text{and} \quad e(\bar{R}^\square(\bar{\rho}, \tau_{\zeta_1, \zeta_2}), \mathfrak{a}_N) = 1,$$

and so we get [Equation \(16\)](#). □

5E. Cohen–Macaulayness. If τ_0 is a semisimple representation of I_F over E , let $R(\bar{\rho}, \tau_0)'$ be the maximal reduced and l -torsion-free quotient of $R(\bar{\rho})$ all of whose \bar{E} -points give rise to representations ρ of G_F with $\rho|_{I_F}^{ss} \cong \tau_0$. Then I claim that $R(\bar{\rho}, \tau_0)'$ is always Cohen–Macaulay. Indeed, if τ_0 is non-scalar then this is proved above. If τ_0 is scalar, then we may twist and assume that it is trivial. If $q \not\equiv \pm 1 \pmod{l}$, this follows from [Proposition 5.5](#). If $q \equiv 1 \pmod{l}$ then we can deduce the claim from [Proposition 5.8](#) together with [[Eisenbud 1995](#), Exercise 18.13], which says that if R/I and R/J are d -dimensional Cohen–Macaulay quotients of a noetherian local ring R , and $\dim R/(I + J) = d - 1$, then $R/(I \cap J)$ is Cohen–Macaulay if and only if $R/(I + J)$ is. We take $R = R^\square(\bar{\rho})$, and I and J to be the ideals cutting out $R^\square(\bar{\rho}, \tau_s)$ and $R^\square(\bar{\rho}, \tau_{ns})$ respectively. Then R/I and R/J are Cohen–Macaulay, and $R/(I + J)$ is a quotient of the formally smooth ring R/I by the single equation $q \operatorname{tr}(\rho^\square(\phi))^2 = (q + 1)^2 \det(\rho^\square(\phi))$, and so is Cohen–Macaulay.

Therefore $R/(I \cap J)$ is Cohen–Macaulay as required. When $q \equiv -1 \pmod{l}$ the claim follows from [Proposition 5.6](#) unless $\bar{\rho}$ is the direct sum of the trivial and cyclotomic characters, in which case we use [Remark 5.7](#).

For n -dimensional representations the unrestricted framed deformation ring $R^\square(\bar{\rho})$ is always Cohen–Macaulay (in fact, a complete intersection; this is due to David Helm, building on work of Choi [\[2009\]](#)). It is natural to wonder whether the rings obtained by fixing the semisimplified restriction to inertia are always Cohen–Macaulay. Note that they are not always Gorenstein.

For a discussion of how the Cohen–Macaulay property of local deformation rings can be used to show that certain global Galois deformation rings are flat over \mathcal{O} , see [\[Snowden 2011, Section 5\]](#).

6. Reduction of types — proofs.

The aim of this section is to analyse the reduction modulo l of the K -types $\sigma(\tau)$ defined in [Section 3](#), and in particular to prove [Lemma 3.9](#).

6A. The essentially tame case. Suppose that $\tau = (r_\tau, N_\tau)$ where r_τ is a tamely ramified, semisimple representation of I_F . Then $\sigma(\tau)$ is inflated from a representation of $GL_2(k_F)$. We will always use the same notation for a representation of $GL_2(k_F)$ and its inflation to $GL_2(\mathcal{O}_F)$. For this subsection let $G = GL_2(k_F)$, let B be the subgroup of upper-triangular matrices, let U be the subgroup of unipotent elements of B , let Z be the centre of G , and fix an embedding $\alpha : k_L^\times \hookrightarrow G$. Fix a nontrivial additive character ψ of U . Then we have (see, e.g., [\[Bushnell and Henniart 2006, Chapter 6\]](#)):

- If $r_\tau = (\text{rec}(\tilde{\chi}) \oplus \text{rec}(\tilde{\chi}))|_{I_F}$ and $N_\tau \neq 0$, where $\tilde{\chi}|_{\mathcal{O}_F^\times}$ is inflated from a character χ of k_F^\times , then $\sigma(\tau) = (\chi \circ \det) \otimes \text{St}$, where St is the Steinberg representation of G .
- If $r_\tau = (\text{rec}(\tilde{\chi}) \oplus \text{rec}(\tilde{\chi}))|_{I_F}$ and $N_\tau = 0$, where $\tilde{\chi}|_{\mathcal{O}_F^\times}$ is inflated from a character χ of k_F^\times , then $\sigma(\tau) = \chi \circ \det$.
- If $r_\tau = (\text{rec}(\tilde{\chi}_1) \oplus \text{rec}(\tilde{\chi}_2))|_{I_F}$, where $\tilde{\chi}_1|_{\mathcal{O}_F^\times}$ and $\tilde{\chi}_2|_{\mathcal{O}_F^\times}$ are inflated from *distinct* characters χ_1 and χ_2 of k_F^\times , then

$$\sigma(\tau) = \mu(\chi_1, \chi_2) := \text{Ind}_B^G(\chi_1 \otimes \chi_2).$$

- If $r_\tau = (\text{Ind}_{G_L}^{G_F} \text{rec}(\tilde{\theta}))|_{I_F}$ where $\tilde{\theta}|_{\mathcal{O}_L^\times}$ is inflated from a character θ of k_L^\times which is not equal to its $\text{Gal}(k_L/k_F)$ conjugate θ^c , then

$$\sigma(\tau) = \pi_\theta := \text{Ind}_{ZU}^G(\theta|_Z \psi) - \text{Ind}_{\alpha(k_L^\times)}^G \theta$$

(this virtual representation is a genuine irreducible representation that is independent of the choice of ψ).

The only isomorphisms between these representations are of the form $\mu(\chi_1, \chi_2) \cong \mu(\chi_2, \chi_1)$ and $\pi_\theta \cong \pi_{\theta^c}$.

We want to understand the reductions of these representations modulo l , for this see [Helm 2010]. We will use analogous notation for representations of G in characteristic zero and in characteristic l ; hopefully this will not cause confusion.

If $q \not\equiv \pm 1 \pmod{l}$, then reduction modulo l is a bijection between irreducible $\overline{\mathbb{F}}_l$ -representations of G and irreducible \overline{E} -representations of G , as G has order $q(q+1)(q-1)^2$ which is coprime to l .

If $q \equiv 1 \pmod{l}$, then the distinct irreducible representations of $\mathrm{GL}_2(k_F)$ over $\overline{\mathbb{F}}$ are $\chi \circ \det$ and $\mathrm{St} \otimes (\chi \circ \det)$ for $\chi : k_F^\times \rightarrow \overline{\mathbb{F}}^\times$, $\mu(\chi_1, \chi_2)$ for $\chi_1, \chi_2 : k_F^\times \rightarrow \overline{\mathbb{F}}^\times$ a pair of distinct characters, and π_θ for $\theta : k_L^\times \rightarrow \overline{\mathbb{F}}^\times$ a character which is not isomorphic to its conjugate. The notation is all entirely analogous to the characteristic zero case. Once again, the only isomorphisms are $\mu(\chi_1, \chi_2) \cong \mu(\chi_2, \chi_1)$ and $\pi_\theta \cong \pi_{\theta^c}$. The reductions of the characteristic zero representations are:

- $\overline{\chi \circ \det} = \overline{\chi} \circ \det$.
- $\overline{\mathrm{St} \otimes \chi \circ \det} = \mathrm{St} \otimes (\overline{\chi} \circ \det)$.
- $\overline{\mu(\chi_1, \chi_2)} = \mu(\overline{\chi}_1, \overline{\chi}_2)$ if $\overline{\chi}_1 \neq \overline{\chi}_2$.
- $\overline{\mu(\chi_1, \chi_2)} = (\overline{\chi} \circ \det) \oplus \mathrm{St} \otimes (\overline{\chi} \circ \det)$ if $\overline{\chi}_1 = \overline{\chi}_2 = \overline{\chi}$.
- $\overline{\pi_\theta} = \pi_{\overline{\theta}}$.

For the last of these, we must observe that θ/θ^c is a character of k_L^\times/k_F^\times , a group which has order $q+1$ and so coprime to l (as $l > 2$). Therefore if $\theta \neq \theta^c$ then $\overline{\theta} \neq \overline{\theta^c}$.

If $q \equiv -1 \pmod{l}$, then the distinct irreducible representations are $\chi \circ \det$ for $\chi : k_F^\times \rightarrow \overline{\mathbb{F}}^\times$, $\mu(\chi_1, \chi_2)$ for $\chi_1, \chi_2 : k_F^\times \rightarrow \overline{\mathbb{F}}^\times$ unordered pair of distinct characters, π_θ for $\theta : k_L^\times \rightarrow \overline{\mathbb{F}}^\times$ a character which is not isomorphic to its conjugate, and $(\chi \circ \det) \otimes \pi_1$ for $\chi : k_F^\times \rightarrow \overline{\mathbb{F}}^\times$ a character. This last needs some explanation, π_1 is the reduction modulo l of π_θ for any character $\theta : k_L^\times/k_F^\times \rightarrow \overline{E}^\times$ which is not equal to θ^c but whose reduction modulo l is trivial. Once again, the only isomorphisms are $\mu(\chi_1, \chi_2) \cong \mu(\chi_2, \chi_1)$ and $\pi_\theta \cong \pi_{\theta^c}$. The reductions of the characteristic 0 representations are:

- $\overline{\chi \circ \det} = \overline{\chi} \circ \det$.
- $\overline{\mu(\chi_1, \chi_2)} = \mu(\overline{\chi}_1, \overline{\chi}_2)$.
- $\overline{\pi_\theta} = \pi_{\overline{\theta}}$ if $\overline{\theta} \neq \overline{\theta^c}$.
- $\overline{\pi_\theta} = \pi_1 \otimes (\overline{\theta}|_{k_F^\times} \circ \det)$ if $\overline{\theta} = \overline{\theta^c}$.
- $\overline{\mathrm{St} \otimes \chi \circ \det}$ has $\pi_1 \otimes (\overline{\chi} \circ \det)$ as a submodule with quotient $\overline{\chi} \circ \det$.

In particular, comparing this analysis with Lemma 3.8 shows:

Lemma 6.1. *If $\tau = (r, 0)$ and $\tau' = (r', 0)$ are scalar on P_F but not on \bar{P}_F , then $\sigma(\tau)$ and $\sigma(\tau')$ are irreducible and are isomorphic if and only if $r \equiv r' \pmod{l}$.*

6B. The wild case. If $\tau = (r, 0)$ and all twists of r are wildly ramified (we say that τ is “essentially wildly ramified”), then the following lemma will allow us to show that $\sigma(\tau)$ is irreducible. If ρ is a $\bar{\mathbb{Z}}_l$ -representation of a group H , we write $\bar{\rho}$ for $\rho \otimes \bar{\mathbb{F}}_l$.

Lemma 6.2. *Suppose that $H \triangleleft J \subset K$ are profinite groups such that H is open in K , H has pro-order coprime to l , and J/H is an abelian l -group. Suppose that λ is a $\bar{\mathbb{Z}}_l$ -representation of J , and write η for the restriction of λ to H . Suppose that η (and hence λ) is irreducible. Suppose that if $g \in K$ intertwines η , then $g \in J$. Then*

- (1) *The representations of J extending η are precisely $\lambda_i = \lambda \otimes v_i$ as v_i run through the characters of J/H . There is an isomorphism $\text{Ind}_H^J \eta \otimes \bar{E} \cong \bigoplus_i \lambda_i$. The unique $\bar{\mathbb{F}}_l$ -representation extending $\bar{\eta}$ is $\bar{\lambda}$, and all of the Jordan–Hölder factors of $\text{Ind}_H^J \bar{\eta}$ are isomorphic to $\bar{\lambda}$.*
- (2) *A $\bar{\mathbb{F}}_l$ -representation ρ of J contains $\bar{\lambda}$ as a subrepresentation if and only if it contains $\bar{\lambda}$ as a quotient.*
- (3) *The representations $\text{Ind}_J^K \lambda_i$ and $\text{Ind}_J^K \bar{\lambda}$ are irreducible.*

Proof.

- (1) In characteristic 0 we argue as follows. First note that the representations λ_i are distinct, otherwise $\lambda|_H$ would have a nonscalar endomorphism, contradicting Schur’s lemma. By Frobenius reciprocity, the λ_i are distinct irreducible constituents of $\text{Ind}_H^J \eta$. Since the sum of their dimensions is $\dim \text{Ind}_H^J \eta$, they are the only irreducible constituents. By Frobenius reciprocity, any representation extending η must occur in $\text{Ind}_H^J \eta$ and so must be one of the λ_i , as required. In characteristic l , first note that $\bar{\lambda}$ is irreducible since the pro-order of H is coprime to l . It follows from this and the fact that \bar{v}_i is trivial for all i that the Jordan–Hölder factors of $\text{Ind}_H^J \bar{\eta}$ are isomorphic to $\bar{\lambda}$. Frobenius reciprocity then implies that $\bar{\lambda}$ is the unique irreducible representation of J extending H .
- (2) It follows from part 1 that $\text{Hom}_J(\bar{\lambda}, \rho) \neq 0$ if and only if $\text{Hom}_J(\text{Ind}_H^J \bar{\eta}, \rho) \neq 0$. By Frobenius reciprocity, this is equivalent to $\text{Hom}_H(\bar{\eta}, \rho) \neq 0$. But by the assumption on the pro-order of H , $\bar{\mathbb{F}}_l$ -representations of H are semisimple, and so this is equivalent to $\text{Hom}_H(\rho, \bar{\eta}) \neq 0$, which by the same argument is equivalent to $\text{Hom}_J(\rho, \text{Ind}_H^J \bar{\eta}) \neq 0$.
- (3) First, note that $\dim \text{Hom}_K(\text{Ind}_J^K \bar{\lambda}, \text{Ind}_J^K \bar{\lambda}) = 1$, by Mackey’s decomposition formula and the assumption that elements of $K \setminus J$ do not intertwine η . Now suppose that ρ is an irreducible subrepresentation of $\text{Ind}_J^K \bar{\lambda}$. By Frobenius reciprocity and part 2 we may deduce that ρ is also an irreducible quotient of $\text{Ind}_J^K \bar{\lambda}$. The composition $\text{Ind}_J^K \bar{\lambda} \twoheadrightarrow \rho \hookrightarrow \text{Ind}_J^K \bar{\lambda}$ is then a nonzero element

of $\text{Hom}_K(\text{Ind}_J^K \bar{\lambda}, \text{Ind}_J^K \bar{\lambda})$, and is therefore scalar. But this is only possible if $\rho = \text{Ind}_J^K \bar{\lambda}$, as required. The statement about $\text{Ind}_J^K \lambda_i$ follows. \square

Proposition 6.3. *Let $\tau = (r, 0)$ be an essentially wildly ramified inertial type. Then there exists a subgroup $J \subset K$, an irreducible representation λ of J , and a subgroup $\tilde{J} \triangleleft J$, such that $(\tilde{J}, J, K, \lambda)$ satisfy the hypotheses on (H, J, K, λ) in Lemma 6.2 and such that $\sigma(\tau) = \text{Ind}_{\tilde{J}}^K \lambda$.*

In particular, $\overline{\sigma(\tau)}$ is irreducible.

Proof. Suppose first that r is the restriction to I_F of a reducible representation of G_F . Then $\sigma(\tau) = \text{Ind}_{K_0(N)}^K \epsilon \otimes (\chi \circ \det)$ for a character ϵ of \mathcal{O}_F^\times of exponent $N \geq 2$ and a character χ of \mathcal{O}_F^\times . Let $J = K_0(N)$, and let

$$\tilde{J} = \left\{ \begin{pmatrix} a & b \\ c & d \end{pmatrix} \in J : a \text{ has order coprime to } l \text{ modulo } \mathfrak{p}_F \right\}.$$

Then \tilde{J} , J , and ϵ satisfy all the required hypotheses — the only one to check is that $\epsilon|_{\tilde{J}}$ is not intertwined by any element of $K \setminus J$. We deduce this (in somewhat circular fashion) from the irreducibility of $\text{Ind}_J^K(\epsilon)$, since this is shorter than a direct proof. If $g \in K$ intertwines $\epsilon|_{\tilde{J}}$, then $\text{Hom}_{\tilde{J} \cap g \tilde{J} g^{-1}}(\epsilon, \epsilon^g) \neq 0$. By Mackey’s formula

$$\dim(\text{Hom}_{\tilde{J}}(\epsilon, \text{Ind}_J^K \epsilon)) = \sum_{g \in \tilde{J} \backslash K / \tilde{J}} \dim \text{Hom}_{\tilde{J} \cap g \tilde{J} g^{-1}}(\epsilon, \epsilon^g).$$

The left hand side is in turn equal to $\dim \text{Hom}_K(\text{Ind}_J^K \epsilon, \text{Ind}_J^K \epsilon)$. But $\text{Ind}_J^K \epsilon = \bigoplus_i \text{Ind}_J^K \epsilon_i$ where ϵ_i are the characters of J extending $\epsilon|_{\tilde{J}}$, and by the appendix to [Breuil and Mézard 2002], these $\text{Ind}_J^K \epsilon_i$ are irreducible and distinct. Therefore the left hand side is equal to $(J : \tilde{J})$. The right hand side has a contribution of 1 from each $g \in J / \tilde{J}$, and therefore from no other g , as required.

Now suppose that r is the restriction to I_F of an irreducible representation of G_F . Then $\sigma(\tau) = \text{Ind}_J^K \lambda$ for an irreducible representation λ of J extending an irreducible representation η of a pro- p normal subgroup J^1 of J (see [Bushnell and Henniart 2006, Sections 15.5, 15.6 and 15.7] — note that our J is the maximal compact subgroup of their J_α , but our J^1 agrees with their J_α^1). We have $J/J^1 = k^\times$, where k is the residue field of a quadratic extension of F , and so J has a normal subgroup \tilde{J} of pro-order coprime to l such that J/\tilde{J} is an l -group. Then $(\tilde{J}, J, K, \lambda)$ satisfy all the required hypotheses — the intertwining statement follows from [Bushnell and Henniart 2006, 15.6 Proposition 2]. \square

Proposition 6.4. *Let $\tau = (r, 0)$ and $\tau' = (r', 0)$ be inertial types that are not scalar on \tilde{P}_F . If $r \equiv r' \pmod{l}$, then $\overline{\sigma(\tau)}$ and $\overline{\sigma(\tau')}$ are isomorphic.*

Proof. If either of r and r' is (after a twist) tamely ramified, then so is the other and this is contained in Lemma 6.1. Otherwise, by Lemma 3.8, we are in one of the following cases:

- (1) $r = (\chi_1 \oplus \chi_2)|_{I_F}$ for characters χ_1 and χ_2 of G_F that are distinct on P_F , and $r' = (\chi'_1 \oplus \chi'_2)|_{I_F}$ for characters χ'_1 and χ'_2 of G_F with $\chi_i \equiv \chi'_i$ for $i = 1, 2$.
- (2) $r = (\text{Ind}_{G_L}^{G_F} \xi)_{I_F}$ and $r' = (\text{Ind}_{G_L}^{G_F} \xi')_{I_F}$ for wildly ramified characters ξ and ξ' of G_L such that $\xi \equiv \xi'$, and such that $\xi|_{\tilde{P}_F}$ does not extend to G_F .
- (3) $r|_{\tilde{P}_F}$ is irreducible and $r' = r \otimes \chi$ for a character χ of I_F that extends to G_F and such that $\chi \equiv 1 \pmod{l}$.

In the first case, we may write $\chi_i = \text{rec}(\epsilon_i)$ and $\chi'_i = \text{rec}(\epsilon'_i)$ with ϵ_i and ϵ'_i characters of F^\times such that $\epsilon_i \equiv \epsilon'_i \pmod{l}$ and such that $\epsilon = \epsilon_1/\epsilon_2$ has exponent $N \geq 1$. Since $\epsilon' = \epsilon'_1/\epsilon'_2$ also has exponent N , we have

$$\begin{aligned} \sigma(\tau) &= \epsilon_2 \otimes \text{Ind}_{K_0(N)}^K \epsilon \\ &\equiv \epsilon'_2 \otimes \text{Ind}_{K_0(N)}^K \epsilon' \pmod{l} \\ &= \sigma(\tau'). \end{aligned}$$

In the second case, by twisting we may reduce to the case where $(L/F, \text{rec}^{-1}(\xi))$ is an unramified minimal admissible pair [Bushnell and Henniart 2006, § 19.6]. Then, following through the explicit construction of [Bushnell and Henniart 2006, SS 19.3 and 19.4] we see that there are

- (1) a simple stratum $(\mathfrak{A}, n, \alpha)$ with associated compact open subgroups $J_1 \subset J \subset K$, with J_1 pro- p and $J/J_1 \cong k_L^\times$,
- (2) a representation η of J^1 and extensions λ and λ' of η to J such that $\text{Ind}_J^K(\lambda) = \sigma(\tau)$ and $\text{Ind}_J^K(\lambda') = \sigma(\tau')$.

Indeed, up to conjugacy, $(\mathfrak{A}, n, \alpha)$, J_1 , and η are determined by $\text{rec}^{-1}(\xi)|_{U_L^1} = \text{rec}^{-1}(\xi')|_{U_L^1}$. The representations λ and λ' are defined in terms of $\text{rec}^{-1}(\xi)$ and $\text{rec}^{-1}(\xi')$ by the formulae of [Bushnell and Henniart 2006, 19.3.1 and Corollary 19.4] (together with the correction factor of paragraph 34.4, an unramified twist Δ_ξ , that makes no difference to the argument). It is clear from these that if $\xi \equiv \xi'$ then $\lambda \equiv \lambda'$ as required.

In the final case, $r' = r \otimes \chi$ for a character χ of I_F that extends to G_F . By compatibility of $\tau \mapsto \sigma(\tau)$ with twisting,

$$\begin{aligned} \sigma(\tau') &= \sigma(\tau) \otimes \text{rec}^{-1}(\chi) \circ \det \\ &\equiv \sigma(\tau) \pmod{l} \end{aligned}$$

as required. □

Proposition 6.5. *Let $\tau = (r, 0)$ and $\tau' = (r', 0)$ be inertial types that are not scalar on \tilde{P}_F . If $\overline{\sigma(\tau)}$ and $\overline{\sigma(\tau')}$ are isomorphic, then $r \equiv r' \pmod{l}$.*

Proof. If one of r and r' has a twist which is trivial on P_F , then so does the other and in this case the proposition follows from Lemma 6.1.

Otherwise we may, by twisting, assume that $\sigma(\tau)$ and $\sigma(\tau')$ satisfy $l(\sigma) \leq l(\sigma \otimes \chi)$ for all characters χ of \mathcal{O}_F^\times (the definition of $l(\sigma)$ is as in [Bushnell and Henniart 2006, § 12.6]). In this case $\sigma(\tau)$ and $\sigma(\tau')$ contain the same, nonempty, sets of fundamental strata (because this only depends on the restriction to pro- p subgroups).

If one of $\sigma(\tau)$ and $\sigma(\tau')$ contains a split fundamental stratum [Bushnell and Henniart 2006, 13.2] then so does the other. In this case, [Bushnell and Henniart 2006, Corollary 13.3] implies that they cannot be cuspidal types and so we have

$$\sigma(\tau) = \text{Ind}_{K_0(N)}^K(\epsilon) \quad \text{and} \quad \sigma(\tau') = \text{Ind}_{K_0(N')}^K(\epsilon')$$

for some ϵ and ϵ' of exponents N and N' . It is easy to see that in fact we must have $N = N'$. From Lemma 6.2 we deduce that $\epsilon \equiv \epsilon' \pmod{l}$, and so $\tau \equiv \tau' \pmod{l}$ as required.

Otherwise, $\sigma(\tau) = \text{Ind}_J^K \lambda$ and $\sigma(\tau') = \text{Ind}_J^K \lambda'$ for a simple stratum $(\mathfrak{A}, n, \alpha)$ with associated groups $J^1 \subset J$ and representations λ and λ' extending the representation η of J . From Lemma 6.2 we deduce that $\lambda' = \lambda \otimes \eta$ for a character η of J/J^1 with $\eta \equiv 1 \pmod{l}$.

If \mathfrak{A} is unramified, then by the reverse of the argument in the second case of the previous proposition we see that $\tau = (\text{Ind}_{G_L}^{G_F} \xi)|_{I_F}$ and $\tau' = (\text{Ind}_{G_L}^{G_F} \xi')|_{I_F}$ for ξ and ξ' characters of G_L with $\xi|_{I_L} \equiv \xi'|_{I_L}$, whence the result.

If \mathfrak{A} is ramified, then η can be regarded as a character of $J/J^1 \cong k_M^\times = k_F^\times$ with $\eta \equiv 1 \pmod{l}$ for some ramified quadratic extension M/F . I claim that there is a character χ of \mathcal{O}_F^\times with $\eta = \chi \circ \det$ and $\chi \equiv 1 \pmod{l}$. Indeed, as $l > 2$ we can take the inflation to \mathcal{O}_F^\times of the character χ of k_F^\times satisfying $\chi \equiv 1 \pmod{l}$ and $\chi^2 = \eta$. Then $\sigma(\tau) = \sigma(\tau') \otimes (\chi \circ \det)$ and so

$$\begin{aligned} \tau &= \tau' \otimes \text{rec}(\chi) \\ &\equiv \tau' \pmod{l}, \end{aligned}$$

as required. □

Acknowledgements

This work forms part of my Imperial College, London PhD thesis, and I am grateful to my supervisor Toby Gee for suggesting this topic, for comments on drafts of this paper, and for answering many questions. I also thank Kevin Buzzard, David Helm, Yongquan Hu, Tristan Kalloniatis, Vytautas Paškūnas for helpful comments and corrections, and Jack Thorne for encouraging me to investigate the Cohen–Macaulay property of these deformation rings.

This research was supported by the Engineering and Physical Sciences Research Council and the Philip Leverhulme Trust, and part of this work was done during a visit to the University of Chicago supported by the London Mathematical Society and the Cecil King Foundation.

References

- [Barnet-Lamb et al. 2014] T. Barnet-Lamb, T. Gee, D. Geraghty, and R. Taylor, “Potential automorphy and change of weight”, *Ann. of Math. (2)* **179**:2 (2014), 501–609. [MR 3152941](#)
- [Breuil and Mézard 2002] C. Breuil and A. Mézard, “Multiplicités modulaires et représentations de $GL_2(\mathbb{Z}_p)$ et de $\text{Gal}(\overline{\mathbb{Q}}_p/\mathbb{Q}_p)$ en $l = p$ ”, *Duke Math. J.* **115**:2 (2002), 205–310. [MR 1944572](#)
- [Bushnell and Henniart 2006] C. J. Bushnell and G. Henniart, *The local Langlands conjecture for GL_2* , Grundlehren der Mathematischen Wissenschaften **335**, Springer, Berlin, 2006. [MR 2234120](#)
- [Choi 2009] S. H. Choi, *Local deformation lifting spaces of mod l Galois representations*, Ph.D. thesis, Harvard University, 2009.
- [Clozel et al. 2008] L. Clozel, M. Harris, and R. Taylor, “Automorphy for some l -adic lifts of automorphic mod l Galois representations”, *Publ. Math. Inst. Hautes Études Sci.* 108 (2008), 1–181. [MR 2470687](#)
- [Eisenbud 1995] D. Eisenbud, *Commutative algebra*, Graduate Texts in Mathematics **150**, Springer, New York, 1995. [MR 1322960](#)
- [Emerton and Gee 2014] M. Emerton and T. Gee, “A geometric perspective on the Breuil–Mézar­d conjecture”, *J. Inst. Math. Jussieu* **13**:1 (2014), 183–223. [MR 3134019](#)
- [Gee and Kisin 2014] T. Gee and M. Kisin, “The Breuil–Mézar­d conjecture for potentially Barsotti–Tate representations”, *Forum Math. Pi* **2** (2014), e1, 56. [MR 3292675](#)
- [Helm 2010] D. Helm, “On l -adic families of cuspidal representations of $GL_2(\mathbb{Q}_p)$ ”, *Math. Res. Lett.* **17**:5 (2010), 805–822. [MR 2727610](#)
- [Henniart 2002] G. Henniart, appendix to [Breuil and Mézard 2002], 2002.
- [Hu and Tan 2013] Y. Hu and F. Tan, “The Breuil–Mézar­d conjecture for non-scalar split residual representations”, preprint, 2013. [arXiv 1309.1658](#)
- [Kisin 2009a] M. Kisin, “The Fontaine–Mazur conjecture for GL_2 ”, *J. Amer. Math. Soc.* **22**:3 (2009), 641–690. [MR 2505297](#)
- [Kisin 2009b] M. Kisin, “Moduli of finite flat group schemes, and modularity”, *Ann. of Math. (2)* **170**:3 (2009), 1085–1180. [MR 2600871](#)
- [Paškūnas 2015] V. Paškūnas, “On the Breuil–Mézar­d conjecture”, *Duke Math. J.* **164**:2 (2015), 297–359. [MR 3306557](#)
- [Pilloni 2008] V. Pilloni, “The study of 2-dimensional p -adic Galois deformations in the l not p case”, 2008, available at <http://perso.ens-lyon.fr/vincent.pilloni/Defo.pdf>.
- [Reduzzi 2013] D. Reduzzi, “On the number of irreducible components of local deformation rings in the unequal characteristic case”, 2013, available at http://msp.org/msp_org/media/files/D.A.Reduzzi-Irreducible_Components_Local_Deformations.pdf.
- [Snowden 2011] A. Snowden, “Singularities of ordinary deformation rings”, 2011. [arXiv 1111.3654](#)
- [Taylor 2008] R. Taylor, “Automorphy for some l -adic lifts of automorphic mod l Galois representations II”, *Publ. Math. Inst. Hautes Études Sci.* 108 (2008), 183–239. [MR 2470688](#)
- [Taylor 2009] R. Taylor, “Modularity lifting theorems”, Lecture notes, Harvard University, 2009.

Communicated by Brian Conrad

Received 2015-04-28

Revised 2016-04-14

Accepted 2016-07-18

jack.shotton@gmail.com

University of Chicago, 5442 S Ellis Ave, Chicago, IL 60615,
United States

Generalized Kuga–Satake theory and rigid local systems, II: rigid Hecke eigensheaves

Stefan Patrikis

We use rigid Hecke eigensheaves, building on Yun’s work on the construction of motives with exceptional Galois groups, to produce the first robust examples of “generalized Kuga–Satake theory” outside the Tannakian category of motives generated by abelian varieties. To strengthen our description of the “motivic” nature of Kuga–Satake lifts, we digress to establish a result that should be of independent interest: for any quasiprojective variety over a (finitely generated) characteristic-zero field, the associated graded of the weight filtration on its intersection cohomology arises from a motivated motive in the sense of André, and in particular from a classical homological motive if one assumes the standard conjectures. This extends work of de Cataldo and Migliorini.

1. Background: generalized Kuga–Satake theory

The aim of this paper is to produce nontrivial examples of the generalized Kuga–Satake theory proposed in [Patrikis 2014b]. The classical Kuga–Satake construction is a miracle of Hodge theory that associates to any complex K3 surface X a complex abelian variety $\text{KS}(X)$ and an inclusion of \mathbb{Q} -Hodge structures

$$H^2(X, \mathbb{Q}) \subset H^1(\text{KS}(X), \mathbb{Q})^{\otimes 2}.$$

This construction takes its clearest conceptual form within the motivic Galois formalism. Let $\mathcal{M}_{\mathbb{C}}^{\text{hom}}$ denote the category of pure motives over \mathbb{C} for homological equivalence. Assuming the standard conjectures, this is a neutral Tannakian category over \mathbb{Q} with fiber functor given by Betti cohomology:

$$H_B : \mathcal{M}_{\mathbb{C}}^{\text{hom}} \rightarrow \text{Vect}_{\mathbb{Q}}.$$

This work was supported by NSF grant DMS-1303928.

MSC2010: primary 14C15; secondary 11F80, 14D24.

Keywords: Galois representations, rigid local systems, Kuga–Satake construction, geometric Langlands.

Let $\mathcal{G}_{\mathbb{C}}^{\text{hom}} = \text{Aut}^{\otimes}(H_B)$ denote the corresponding Tannakian group. Then we can phrase the Kuga–Satake construction as follows: the motive $H^2(X)$ admits a (symmetric) polarization, hence (normalizing by a Tate-twist to weight zero) corresponds to a motivic Galois representation $\rho : \mathcal{G}_{\mathbb{C}}^{\text{hom}} \rightarrow \text{SO}(H_B^2(X)(1))$.¹ The motive $H^1(\text{KS}(X))$ then *is* the motivic Galois representation corresponding to the composite $r \circ \tilde{\rho}$ in the diagram

$$\begin{array}{ccc}
 \text{GSpin}(H_B^2(X)(1)) & \xrightarrow{r} & \text{GL}(C^+(H_B^2(X)(1))) \\
 \tilde{\rho} \nearrow \text{---} & & \downarrow \\
 \mathcal{G}_{\mathbb{C}}^{\text{hom}} & \xrightarrow{\rho} & \text{SO}(H_B^2(X)(1))
 \end{array} \tag{1}$$

in which $\tilde{\rho}$ is a suitable lift of ρ , and r is the natural representation of GSpin on the even Clifford algebra. The strongest possible version of the Kuga–Satake construction is the statement that such a lift $\tilde{\rho}$ exists; this is far from known at present, as it implicitly includes deep cases of the Lefschetz standard conjecture. A weaker, but still highly nontrivial, analogue is known when $\mathcal{G}_{\mathbb{C}}^{\text{hom}}$ is replaced by the motivic Galois group of André’s category of motives for motivated cycles; see [André 1996a].

But the formulation itself is highly suggestive, pointing towards deep and largely unexplored generalizations, some of whose essential difficulties are orthogonal to the usual impenetrable conjectures of algebraic and arithmetic geometry — Lefschetz, Hodge, Tate, etc. In what follows we will work with motives over number fields and their ℓ -adic realizations, rather than motives over \mathbb{C} and their Hodge–Betti realizations, but there are analogues of the results of this paper in the latter setting. We now state a conjecture that captures the most refined form of a “generalized Kuga–Satake theory” for motives over number fields. For two number fields F and E , we let $\mathcal{M}_{F,E}$ denote the category of motives for motivated cycles over F with coefficients in E ; it is (unconditionally) neutral Tannakian over E , and by choosing an embedding $F \hookrightarrow \mathbb{C}$, the (E -linear) Betti fiber functor gives us its motivic Galois group $\mathcal{G}_{F,E}$ (see [André 1996b] for background).

Conjecture 1.1 (see Section 4.3 of [Patrikis 2014b]). *Let $\tilde{H} \rightarrow H$ be a surjection of linear algebraic E -groups whose kernel is equal to a central torus in \tilde{H} , and let*

$$\rho : \mathcal{G}_{F,E} \rightarrow H$$

be a motivic Galois representation. Then if either F is totally imaginary, or the “Hodge numbers” of ρ satisfy the (necessary) parity condition of [Patrikis 2015,

¹That this motivic Galois representation should be special orthogonal, rather than merely orthogonal, is nontrivial; it follows from work of André [1996a].

Proposition 5.5], then there exists a finite extension E'/E and a lifting

$$\begin{array}{ccc}
 & & \tilde{H}_{E'} \\
 & \nearrow \tilde{\rho} & \downarrow \\
 \mathcal{G}_{F, E'} & \xrightarrow{\rho \otimes_E E'} & H_{E'}
 \end{array}$$

of motivic Galois representations.

For a leisurely overview of this conjecture, see the introduction to [Patrikis 2014a]; for a detailed discussion of the arithmetic evidence, see [Patrikis 2014b]. Even working with motivated rather than homological motives, this conjecture is highly refined: in the classical setting of diagram (1), the existence of such a $\tilde{\rho}$ requires not only the existence of $\text{KS}(X)$, but also the full force of the theorem of Deligne–André that Hodge cycles on abelian varieties are motivated.² At first approximation, though, we can replace Conjecture 1.1 with the following variant:

Definition 1.2. Setting $\Gamma_F = \text{Gal}(\bar{F}/F)$ for an algebraic closure \bar{F} of F , we let $\rho : \Gamma_F \rightarrow H(\bar{\mathbb{Q}}_\ell)$ be a geometric Galois representation valued in an arbitrary linear algebraic group H over $\bar{\mathbb{Q}}_\ell$.

- We say that ρ is weakly motivic if there exists a faithful representation $r : H \hookrightarrow \text{GL}(V_r)$ such that $r \circ \rho$ is isomorphic to the $(\iota : E \hookrightarrow \bar{\mathbb{Q}}_\ell)$ -realization $H_\iota(M)$ of some object M of $\mathcal{M}_{F, E}$.
- Suppose that we are given such a weakly motivic $\rho : \Gamma_F \rightarrow H(\bar{\mathbb{Q}}_\ell)$, and let $\tilde{\rho}$ be a geometric lift to \tilde{H} :

$$\begin{array}{ccc}
 & & \tilde{H}(\bar{\mathbb{Q}}_\ell) \\
 & \nearrow \tilde{\rho} & \downarrow \\
 \Gamma_F & \xrightarrow{\rho} & H(\bar{\mathbb{Q}}_\ell)
 \end{array} \tag{2}$$

(That such geometric lifts typically exist is [Patrikis 2014b, Theorem 3.2.10] and [Patrikis 2015, Proposition 5.5].)³ We say that $\tilde{\rho}$ satisfies the generalized Kuga–Satake property if it is weakly motivic as an \tilde{H} -representation.

²For $F = \mathbb{C}$, that is. When F is a number field, the existence of $\tilde{\rho}$ requires the Tate conjecture for abelian varieties, and rather delicate descent arguments — see [Patrikis 2014b, §4.2].

³This should be contrasted with the situation in which the kernel of $\tilde{H} \rightarrow H$ is finite, where geometric lifts, even after allowing a finite base change on F , need not exist: for a simple example, consider the case $\text{SL}_2 \rightarrow \text{PGL}_2$ in which ρ is the projective representation associated to the Tate module of an elliptic curve (or even more simply, consider multiplication by $N > 1$ on \mathbb{G}_m , and let ρ be the cyclotomic character). For the full story, see [Wintenberger 1995].

In sum, our aim in establishing certain cases of this “generalized Kuga–Satake property” is to verify (motivated refinements of) certain cases of the Fontaine–Mazur conjecture.

With this framework in place, we can introduce the particular setting of this paper. Our aim is to study certain families of weakly motivic $\rho : \Gamma_F \rightarrow H(\bar{\mathbb{Q}}_\ell)$ for which it is possible to find lifts $\tilde{\rho} : \Gamma_F \rightarrow \tilde{H}(\bar{\mathbb{Q}}_\ell)$ satisfying the generalized Kuga–Satake property. Outside of the context of the classical Kuga–Satake construction, where ρ is the representation on $H^2(X_{\bar{F}}, \bar{\mathbb{Q}}_\ell)$, for X/F a K3 surface — or closely related examples in which the motives in question are still generated by motives of abelian varieties⁴ — there were no nontrivial examples of such a lifting until [Patrikis 2014a]. But that paper is restricted to low-dimensional examples in which $\tilde{H} = \mathrm{GSpin}_5 \rightarrow H = \mathrm{SO}_5$, and relies heavily on low-dimensional coincidences in the Dynkin classification. Thus the primary desiderata for our examples are that:

- (D.1) the motives in question not lie in the Tannakian subcategory of \mathcal{M}_F generated by abelian varieties and Artin motives;
- (D.2) the examples exist in arbitrary rank, or at least for “interesting” groups H ;
- (D.3) the lift $\tilde{\rho}$ should not be realizable within the Tannakian category of geometric representations generated by ρ , characters, and Artin representations.

We make explicit this last desideratum just to point out that for some choices of \tilde{H} , for instance $\tilde{H} = H \times \mathbb{G}_m$, the existence of a weakly motivic lift $\tilde{\rho}$ is completely trivial. Condition (D.3) is a way to ensure the results we prove have nontrivial content.

The examples of this paper meet all three criteria of interest. For our ρ we take the remarkable weakly motivic Galois representations constructed in [Yun 2014a, Theorem 4.2, Proposition 4.6]. Let us recall a somewhat simplified version of the main result of [Yun 2014a]. Let G be a split, simple, simply connected group of type A_1 , D_n with n even, G_2 , E_7 , or E_8 , and let G^\vee denote the split \mathbb{Q} -form of its dual group. We have to say a word about the coefficients of the Galois representations and motives. For definiteness, fix an embedding $\bar{\mathbb{Q}} \hookrightarrow \bar{\mathbb{Q}}_\ell$, implicit whenever we take “the” ℓ -adic realization of a motive with coefficients in $\bar{\mathbb{Q}}$, and let i be a square-root of -1 in $\bar{\mathbb{Q}}$. All the local systems considered can be arranged to have coefficients in the (possibly trivial) extension $\mathbb{Q}'_\ell = \mathbb{Q}_\ell(i)$. The motives will have coefficients in the subfield $\mathbb{Q}' \subset \bar{\mathbb{Q}}$ given by

$$\mathbb{Q}' = \begin{cases} \mathbb{Q} & \text{in types } D_{4m}, G_2, E_8, \\ \mathbb{Q}(i) & \text{in types } A_1, D_{4m+2}, E_7. \end{cases} \tag{3}$$

There is a certain two-fold cover $(^2)Z_G \twoheadrightarrow Z_G$ (see Definition 4.1 and Lemma 4.2) of the center Z_G of G — regard $(^2)Z_G$ as a group scheme over \mathbb{Q} — and we call a

⁴For an “axiomatic” generalization of this context, see [André 1996a], which, for instance, further allows X to be a hyperkähler variety, or a cubic four-fold.

character

$$\chi : {}^{(2)}Z_G(\overline{\mathbb{Q}}) \rightarrow \overline{\mathbb{Q}}^\times$$

odd if it is nontrivial on the kernel of ${}^{(2)}Z_G \rightarrow Z_G$.

Theorem 1.3 [Yun 2014a]. *For any odd character $\chi : {}^{(2)}Z_G(\overline{\mathbb{Q}}) \rightarrow \overline{\mathbb{Q}}^\times$, there exists a local system*

$$\rho_\chi : \pi_1(\mathbb{P}_{\mathbb{Q}}^1 - \{0, 1, \infty\}) \rightarrow G^\vee(\mathbb{Q}'_\ell)$$

whose geometric monodromy group is G^\vee , except in type D_{2m} , in which case the geometric monodromy group is SO_{4m-1} . For all number fields F such that

$$F \supseteq \begin{cases} \mathbb{Q} & \text{if } G \text{ is of type } D_{4m}, G_2, \text{ or } E_8, \\ \mathbb{Q}(\sqrt{-1}) & \text{if } G \text{ is of type } A_1, D_{4m+2}, \text{ or } E_7, \end{cases}$$

and all specializations $t : \mathrm{Spec} F \rightarrow \mathbb{P}^1 - \{0, 1, \infty\}$, the pullback $\rho_{\chi,t} : \Gamma_F \rightarrow G^\vee(\mathbb{Q}'_\ell)$ is weakly motivic. To be precise, the composition of $\rho_{\chi,t}$ with the quasiminuscule representation of G^\vee is isomorphic to the \mathbb{Q}'_ℓ -realization of an object of $\mathcal{M}_{F,\mathbb{Q}'}$.

We can now state the first main result of this paper. There is a minor technicality in the phrasing of this theorem that results very naturally from the way the geometric Satake isomorphism descends to number fields—see Section 4B for a careful explanation. Namely, for any connected reductive group H , let ρ^\vee denote the usual half-sum of the positive coroots (for any choice of based root datum), and set $H_1 = (H \times \mathbb{G}_m) / \langle (2\rho^\vee(-1) \times -1) \rangle$. In the case $H = G^\vee$, to avoid cluttered notation we write G_1^\vee for $(G^\vee)_1$; this should not cause any confusion. Yun’s construction is most naturally viewed as the construction of a local system

$$\rho_\chi : \pi_1(\mathbb{P}_{\mathbb{Q}}^1 - \{0, 1, \infty\}) \rightarrow G_1^\vee(\mathbb{Q}'_\ell) = (G^\vee \times \mathbb{G}_m)(\mathbb{Q}'_\ell)$$

in which the G^\vee component is as in Theorem 1.3, and the \mathbb{G}_m component is the cyclotomic character; the equality here uses the fact that G is simply connected.

Theorem 1.4. *Let $\tilde{H} \twoheadrightarrow G^\vee$ be any surjection of split connected reductive groups with kernel equal to a central torus in \tilde{H} . Then:*

- (1) *There exists a local system $\tilde{\rho}_\chi : \pi_1(\mathbb{P}_{\mathbb{Q}(\sqrt{-1})}^1 - \{0, 1, \infty\}) \rightarrow \tilde{H}_1(\mathbb{Q}'_\ell)$ lifting ρ_χ , i.e., such that the diagram*

$$\begin{array}{ccc} & & \tilde{H}_1(\mathbb{Q}'_\ell) \\ & \nearrow \tilde{\rho}_\chi & \downarrow \\ \pi_1(\mathbb{P}_{\mathbb{Q}(\sqrt{-1})}^1 - \{0, 1, \infty\}) & \xrightarrow{\rho_\chi} & G_1^\vee(\mathbb{Q}'_\ell) \end{array}$$

commutes. When G is of type D_{4m} , we may replace $\mathbb{Q}(\sqrt{-1})$ by \mathbb{Q} in this assertion.

- (2) For all number field specializations $t : \text{Spec } F \rightarrow \mathbb{P}^1 - \{0, 1, \infty\}$ (assuming $F \supset \mathbb{Q}(\sqrt{-1})$ in types A_1 , D_{4m+2} , and E_7), $\tilde{\rho}_{\chi,t}$ is weakly motivic, i.e., satisfies the generalized Kuga–Satake property.

The real content of this result is for G of types D_{2m} and E_7 . When $\pi_1(G) = \{1\}$ (types G_2 , E_8), there can never be any generalized Kuga–Satake lift satisfying criterion (D.3). In type A_1 , the construction is not completely trivial, but the motives in question are generated by abelian varieties and Artin motives, so fail to satisfy our criterion (D.1).⁵ But in the essential cases of types D_{2m} and E_7 , all of our desiderata are met, the key point being that, for suitable choice of \tilde{H} , the group \tilde{H}_1 has irreducible representations restricting to each of the minuscule representations of the simply connected cover G_{sc}^\vee of G^\vee ; these are representations not possessed by the original (adjoint) group G^\vee . See Section 6 for details.

We now briefly summarize the approach to constructing the lifted local systems $\tilde{\rho}_\chi$ (see the beginning of Section 2 for more orientation). Yun’s ρ_χ is constructed as the eigen-local system associated to a Hecke eigensheaf on a certain moduli space Bun of G -bundles on \mathbb{P}^1 with level structure at the points $\{0, 1, \infty\}$. Simply put, we enlarge the center of the semisimple group G to form a reductive group \tilde{G} (whose dual group \tilde{G}^\vee plays the role of \tilde{H} above); then we study an analogous moduli space $\widetilde{\text{Bun}}$ of \tilde{G} -bundles with level structure, and show that Yun’s eigensheaves can be extended to eigensheaves on $\widetilde{\text{Bun}}$. The weakly motivic nature of the lifts $\tilde{\rho}_{\chi,t}$ is realized in the (restricting to the interesting cases in type A_1 , D_{2m} , E_7) minuscule representations of \tilde{G}^\vee (or rather, of \tilde{G}_1^\vee); as in [Yun 2014a], the motives themselves are closely related to the (intersection) cohomology of certain open subvarieties of affine Schubert varieties.

To put this approach in perspective, let us note that it is a geometric analogue of the classical automorphic construction parallel to the lifting problem (2). Namely, extending an automorphic representation of G to \tilde{G} heuristically corresponds to lifting a representation $\mathcal{L}_F \rightarrow G^\vee(\mathbb{C})$ of the “automorphic Langlands group” \mathcal{L}_F to $\tilde{G}^\vee(\mathbb{C})$. We are carrying out an analogue for certain Hecke eigensheaves, being careful to retain hold of the explicit “motivic” nature of the corresponding eigen-local systems.

In fact, we prove something considerably stronger than Theorem 1.4, strengthening the “motivic” result even in Yun’s original context. Rather than showing (as in Theorem 1.4(2)) that the $\tilde{\rho}_{\chi,t}$ (or $\rho_{\chi,t}$) are weakly motivic, we show (Theorem 6.1) that, for *any* finite-dimensional representation r of \tilde{H}_1 , $r \circ \tilde{\rho}_{\chi,t}$ is motivated. The content of this assertion is the following: the arguments showing that $\rho_{\chi,t}$ and $\tilde{\rho}_{\chi,t}$ are weakly motivic rest on the fact that quasiminuscule and minuscule affine

⁵Also, in this case, a more elementary construction of the lift can be achieved using Katz’s theory [1996] of rigid local systems; this is a simple case of the strategy of [Patrikis 2014a].

Schubert varieties have very mild singularities (punctual in the quasiminuscule case; none at all in the minuscule case). For such varieties (and their close cousins that appear in the proof), we can in quite elementary terms describe their intersection cohomology groups as the ℓ -adic realizations of motivated motives. The claim that *all* $r \circ \tilde{\rho}_{\chi,t}$ are motivated depends on a similar description, but for varieties with singularities as bad as those of any affine Schubert variety. This essentially means we need a “motivated” description of the intersection cohomology $\mathrm{IH}^*(Y_{\bar{k}}, \mathbb{Q}_{\ell})$ of an arbitrarily singular, and not necessarily projective, variety Y over a characteristic-zero field k ; to be precise, since motivated motives do not reflect “mixed” behavior, we prove such an assertion for the associated weight graded $\mathrm{Gr}_i^W \mathrm{IH}^*(Y_{\bar{k}}, \mathbb{Q}_{\ell})$. This is deduced as a consequence of a stronger “motivated” variant of the decomposition theorem, and especially from a “motivated support decomposition” — see [Theorem 8.13](#) and [Corollary 8.14](#). Here is the specialized statement for intersection cohomology:

Theorem 1.5 (compare [Corollary 8.15](#)). *Let k be a finitely generated field of characteristic zero, and let Y/k be any quasiprojective variety. Then there is an object $M \in \mathcal{M}_k$ whose ℓ -adic realization is isomorphic as a Γ_k -representation to $\mathrm{Gr}_i^W \mathrm{IH}^m(Y_{\bar{k}}, \mathbb{Q}_{\ell})$. If Γ is a finite group scheme over k acting on Y , and $e \in \bar{\mathbb{Q}}[\Gamma(\bar{k})]^{\Gamma_k}$ is an idempotent, then for any embedding $\bar{\mathbb{Q}} \hookrightarrow \bar{\mathbb{Q}}_{\ell}$ there is an object of $\mathcal{M}_{k, \bar{\mathbb{Q}}}$ whose $(\bar{\mathbb{Q}} \hookrightarrow \bar{\mathbb{Q}}_{\ell})$ -realization is isomorphic as a Γ_k -representation to $\mathrm{Gr}_i^W e(\mathrm{IH}^m(Y_{\bar{k}}, \bar{\mathbb{Q}}_{\ell}))$.*

The same holds for intersection cohomology with compact supports.

When Y is projective, in which case $\mathrm{IH}^m(Y_{\bar{k}}, \mathbb{Q}_{\ell})$ is pure of weight m , and k is algebraically closed, this⁶ is a recent result of de Cataldo and Migliorini [[2014](#), [Theorem 3.2.2](#)], part of their beautiful series of papers (see for instance [[de Cataldo and Migliorini 2005](#); [2010](#); [de Cataldo 2012](#)]) reestablishing the decomposition theorem and its associated mixed Hodge-theoretic package by “geometric”, rather than “sheaf-theoretic”, methods. These papers chart a fundamental advance in our understanding of the geometry of perverse sheaves, and I expect there will be many more, and far deeper, motivic applications than the one here. Since the arguments establishing [Theorem 1.5](#) are independent of those of the rest of this paper, I refer the reader to [Section 7A](#) for a fuller introduction, and for an overview of the approach to [Theorem 1.5](#). Also see [Remark 8.16](#) for additional applications, such as a p -adic de Rham comparison isomorphism for intersection cohomology.

⁶Not exactly, of course, since as we have phrased the result the theorem is vacuous for k algebraically closed; in that case substitute for the ℓ -adic cohomology the collection of Betti, de Rham, and ℓ -adic realizations.

2. Bundles with level structure

Before plunging into the technical details, we give a little more orientation for the reader not familiar with Yun’s argument. The principle underlying Yun’s strategy is that, for a suitable reductive group G and a careful choice of level structure (i.e., ramification), there will be an essentially unique automorphic form on G over the function field $F = \mathbb{F}_q((t))$. The usual double coset space

$$G(F) \backslash G(A_F) / \prod_x G(\mathcal{O}_x),$$

the product taken over closed points of X , and \mathcal{O}_x the complete local ring at x , on which automorphic forms are defined admits an interpretation as the \mathbb{F}_q -points of the moduli stack Bun_G of G -bundles on \mathbb{P}^1 . Appropriate moduli spaces of bundles with level structure then have \mathbb{F}_q -points corresponding to taking other level structures in the above double quotient. The general aspiration of (“classical”) geometric Langlands is to upgrade these automorphic functions to perverse sheaves (via Grothendieck’s function-sheaf correspondence) on the appropriate moduli stack of bundles. The automorphic interpretation plays no direct role in Yun’s work, but it serves as motivation. Setting the motivation aside, the problem becomes one of finding level structures corresponding to some moduli space Bun whose simple perverse sheaves can be explicitly described (in fact, what is described in Yun’s case is a subset of “odd” perverse sheaves). To construct eigen-local systems associated to any of these perverse sheaves, one needs to know that they are Hecke eigensheaves. It is here that the uniqueness properties of the construction are absolutely essential: the classical analogue to keep in mind is the statement that in a one-dimensional space of classical modular forms, every element must be a Hecke eigenform! The motivic nature of the resulting local systems is only revealed by carefully tracing through the construction.

The present section reviews facts about spaces of bundles with level structure. The next section then lays out carefully the construction of Yun’s moduli space Bun , and of the enlarged moduli space $\widetilde{\text{Bun}}$ essential to our generalization; this latter space will be chosen to make as easy as possible a comparison of perverse sheaves on the two spaces.

We now proceed to the formal exposition. In this section only, we allow G to be any connected reductive group over a field k , and X to be any smooth projective geometrically connected curve over k . Our aim is to review a construction from [Yun 2011, §4.2] of moduli spaces of G -bundles on X with level structure at a finite set $S = \{x_1, \dots, x_n\} \subset X(k)$ of k -points. Here and throughout, we denote by LG and L^+G the “abstract” loop group and positive loop group of G , i.e., the functors of k -algebras given by $R \mapsto G(R((t)))$ and $R \mapsto G(R[[t]])$ (a group ind-scheme and pro-algebraic group, respectively, over k), where t is a formal parameter. Now

let x be a closed point of X , and denote by \mathcal{O}_x the complete local ring of X at x , with residue field $\kappa(x)$ and fraction field \mathcal{K}_x . Then we denote by $L_x G$ and $L_x^+ G$ the functors $R \mapsto G(R \widehat{\otimes}_{\kappa(x)} \mathcal{K}_x)$ and $R \mapsto G(R \widehat{\otimes}_{\kappa(x)} \mathcal{O}_x)$.

Definition 2.1. Let $\text{Bun}_{G,S,\infty} \rightarrow \text{Ring}_k$ be the stack associated to the following prestack $\text{Bun}_{G,S,\infty}^{\text{pre}}$ over k : for any k -algebra R , $\text{Bun}_{G,S,\infty}^{\text{pre}}(R)$ is the groupoid of triples $(\alpha, \mathcal{P}, \tau)$ where:

- $\alpha = (\alpha_{x_i})_{i=1,\dots,n}$ is a collection of local coordinates $\alpha_{x_i} : R[[t]] \xrightarrow{\sim} \mathcal{O}_{x_i}$ (here we regard x_i as an R -point $x_i : \text{Spec } R \rightarrow X_R$ and take the formal completion of X_R along the graph $\Gamma(x_i)$).
- \mathcal{P} is a G -torsor on X_R .
- $\tau = (\tau_{x_i})_{i=1,\dots,n}$ is a collection of full level structures

$$\tau_{x_i} : G \times \mathcal{D}_{x_i} \xrightarrow{\sim} \mathcal{P}|_{\mathcal{D}_{x_i}},$$

where $\mathcal{D}_{x_i} = \text{Spec}(\mathcal{O}_{x_i})$.

Let $\text{Aut}_{\mathcal{O}}$ denote the pro-algebraic group of continuous automorphisms of $k[[t]]$. The semidirect product

$$(LG \rtimes \text{Aut}_{\mathcal{O}})^n$$

acts on the right on $\text{Bun}_{G,S,\infty}$ as follows.

Definition 2.2. For $g = (g_i)_{i=1,\dots,n} \in G(R((t)))^n$ and $\sigma = (\sigma_i)_{i=1,\dots,n} \in \text{Aut}(R[[t]])^n$, and $(\alpha, \mathcal{P}, \tau) \in \text{Bun}_{G,S,\infty}^{\text{pre}}(R)$, let (g, σ) act on $(\alpha, \mathcal{P}, \tau)$ by

$$R_{g,\sigma}(\alpha, \mathcal{P}, \tau) = (\alpha \circ \sigma, \mathcal{P}^g, \tau^g),$$

where:

- $\alpha \circ \sigma = (\alpha_{x_i} \circ \sigma_i)_i$.
- \mathcal{P}^g is the G -bundle on X_R obtained by gluing $\mathcal{P}|_{X_R - \bigcup_i \Gamma(x_i)}$ to the trivial G -bundles on the completions $\mathcal{D}_{x_i} = \mathcal{O}_{x_i}$ along the punctured discs $\mathcal{D}_{x_i}^\times$ via the isomorphisms

$$G \times \mathcal{D}_{x_i}^\times \xrightarrow{\alpha_{x_i} \circ g_i \circ \alpha_{x_i}^{-1}} G \times \mathcal{D}_{x_i}^\times \xrightarrow{\tau_{x_i}} \mathcal{P}|_{\mathcal{D}_{x_i}^\times}.$$

- $\tau^g = (\tau_{x_i}^g)_{i=1,\dots,n}$ consists of the *tautological* trivializations of \mathcal{P}^g over each \mathcal{D}_{x_i} coming from the definition of \mathcal{P}^g .

At each of the points x_i , we now fix a pro-algebraic subgroup P_i of LG that is stable under the action of $\text{Aut}_{\mathcal{O}}$; we additionally require that, for some integer m , P_i should contain the subgroup

$$I(m) = \{g \in L^+ G : g \equiv 1 \pmod{t^m}\}$$

in finite codimension.

Definition 2.3. Having fixed $S = \{x_1, \dots, x_n\}$ and $\mathbf{P}_1, \dots, \mathbf{P}_n$ as above, we define $\text{Bun}_{G,S}(\mathbf{P}_1, \dots, \mathbf{P}_n)$ to be the stack associated to the quotient prestack

$$R \mapsto \text{Bun}_{G,S,\infty}(R) / \prod_{i=1}^n (\mathbf{P}_i \rtimes \text{Aut}_{\mathcal{O}}(R)).$$

When there is no risk of confusion, we omit the subscript S from the notation and simply write $\text{Bun}_G(\mathbf{P}_1, \dots, \mathbf{P}_n)$.

Note that since the action of $(LG \rtimes \text{Aut}_{\mathcal{O}})^n$ does not necessarily preserve the isomorphism class of the G -torsor \mathcal{P} on X_R , the moduli space $\text{Bun}_{G,S}(\mathbf{P}_1, \dots, \mathbf{P}_n)$ need not have a projection to Bun_G . The action does not alter $\mathcal{P}|_{X_R - \bigcup_i \Gamma(x_i)}$, however, so an object of $\text{Bun}_{G,S}(\mathbf{P}_1, \dots, \mathbf{P}_n)(R)$ does yield a well-defined G -torsor on this complement. Also, the category $\text{Bun}_{G,S}(\mathbf{P}_1, \dots, \mathbf{P}_n)$ has a tautological object given by taking the image of an object of $\text{Bun}_{G,S,\infty}^{\text{pre}}(k)$ given by the trivial bundle with its tautological level structures and any fixed choice of local coordinates α_{x_i} . (For any two such choices, the resulting objects of $\text{Bun}_{G,S,\infty}(k)$ become uniquely isomorphic modulo the $\text{Aut}_{\mathcal{O}}^n$ -action.)

Lemma 2.4. $\text{Bun}_{G,S}(\mathbf{P}_1, \dots, \mathbf{P}_n)$ is an algebraic stack locally of finite type.

Proof. This follows exactly as in [Yun 2014a, Corollary 4.2.6], by first deducing the result for

$$\text{Bun}_{G,S}(\mathbf{I}_1(m), \dots, \mathbf{I}_n(m))$$

from the (well-known) result for Bun_G , and from there deducing the case of $\text{Bun}_{G,S}(\mathbf{P}_1, \dots, \mathbf{P}_n)$. □

Just as in [Yun 2014a, Lemma 4.2.5], we also have:

Lemma 2.5. For each $i = 1, \dots, n$, let

$$\Omega_{x_i} = N_{LG}(\mathbf{P}_i) / \mathbf{P}_i.$$

Then there is a right-action of Ω_{x_i} on $\text{Bun}_{G,S}(\mathbf{P}_1, \dots, \mathbf{P}_n)$.

Finally, we can replace any \mathbf{P}_i by some finite cover, still acting on $\text{Bun}_{G,S,\infty}$ on the right through \mathbf{P}_i ; Lemmas 2.4 and 2.5 continue to hold.

Remark 2.6. For the reader’s convenience, we put this statement in its classical context: Let

$$\Theta := G(F) \backslash G(\mathbb{A}_F) / \left(\prod_{x \neq x_i} G(\mathcal{O}_x) \times \prod_i \mathbf{P}_i \right).$$

Then on automorphic forms $f : \Theta \rightarrow \bar{\mathbb{Q}}_{\ell}$ over a function field F , we have the usual action by Hecke correspondences arising from decomposing the double coset $\mathbf{P}_i w \mathbf{P}_i$ into single cosets. But when w normalizes \mathbf{P}_i , the Hecke action comes from an actual automorphism (right-translation) of the moduli space Θ .

3. Our setting

Now we describe in detail the moduli spaces of G -bundles studied in this paper, taking [Yun 2014a] as our starting point. Let G be a split (almost-)simple simply connected group over k , satisfying the following two hypotheses:

- G is oddly laced;
- -1 belongs to the Weyl group W_G of G .

Explicitly, we take G to be a split simple simply connected group of type A_1 , D_{2n} , G_2 , E_7 , or E_8 in the Dynkin classification. In fact, as we will see, the results of this paper are only nontrivial when the simply connected and adjoint forms of G differ — so for all practical purposes, we are working with types A_1 , D_{2n} , and E_7 .

Let \tilde{G} be a split connected reductive group over k with derived group equal to G , so that the quotient $\tilde{G}/G = S$ is a torus; call the quotient map $\nu : \tilde{G} \rightarrow S$. Fix a maximal torus \tilde{T} of \tilde{G} and a Borel subgroup \tilde{B} containing \tilde{T} , likewise giving $T = \tilde{T} \cap G$, $B = \tilde{B} \cap G$, and determining based root data for \tilde{G} and G , and an explicit Weyl group W_G defined in terms of T . We denote by \tilde{Z} and Z_G the centers of \tilde{G} and G , and we let \tilde{Z}^0 be the identity component of \tilde{Z} . Note that in all cases under consideration $Z_G = Z_G[2]$. The cases of particular interest for us — in which there is a nontrivial Kuga–Satake lifting problem — are those in which $Z_G \neq \{1\}$, namely types A_1 , D_{2n} , and E_7 . From now on we

assume the characteristic of k is not 2. (4)

In particular, Z_G is a discrete group scheme over k , and the order of the kernel of the isogeny $\tilde{Z} \rightarrow S$ is invertible in k . Our first task is to define the moduli spaces of \tilde{G} -bundles on $X = \mathbb{P}^1$ with level structure that will supply us with Hecke eigensheaves. We first recall the construction in [Yun 2014a]. Yun works with the following conjugacy class of parahoric subgroups in LG (see [Yun 2014a, §§2.2–2.3]). In the apartment $\mathcal{A}(T)$ associated to T of the building of LG , we can choose as origin the point corresponding to the subgroup L^+G , with the resulting identification $\mathcal{A}(T) \cong X_\bullet(T) \otimes \mathbb{R}$. Then under this identification $\frac{1}{2}\rho^\vee$ lies in a unique facet, and we let $P_{\frac{1}{2}\rho^\vee}$ be the parahoric subgroup associated to this facet. More precisely, Bruhat–Tits theory provides, for any facet a in the building of LG , a smooth group scheme \mathcal{P}_a over $k[[t]]$ with connected fibers whose generic fiber is $G \times_{\text{Spec } k} \text{Spec } k((t))$. We define P_a to be the pro-algebraic subgroup of LG representing the functor (of k -algebras)

$$R \mapsto \mathcal{P}_a(R[[t]]).$$

We then apply this construction to the case where a is the facet containing $\frac{1}{2}\rho^\vee$. Let K denote the maximal reductive quotient of $P_{\frac{1}{2}\rho^\vee}$; since G is simply connected, K is

connected. Moreover, Yun shows [2014a, §2.5] that K has a canonical connected double cover:

Definition 3.1. Let ${}^{(2)}K$ denote the connected double cover of K , so there is an exact sequence

$$1 \rightarrow \mu_2^{\ker} \rightarrow {}^{(2)}K \rightarrow K \rightarrow 1.$$

Note that our notation differs from that of [Yun 2014a, §2.5], where this group is denoted \tilde{K} ; we reserve $(\tilde{*})$ for groups associated with the enlargement \tilde{G} of G .

We now define the particular moduli stacks of interest, beginning with the ones used in [Yun 2014a]. Let $P_0 \subset L_0G$ be the parahoric subgroup in the conjugacy class of $P_{\frac{1}{2}\rho^\vee}$ that contains the Iwahori $I_0 \subset L_0^+G$, defined in terms of B . Moreover, let

$${}^{(2)}P_0 = P_0 \times_{K_0} {}^{(2)}K_0,$$

and let P_0^+ denote the pro-unipotent radical of P_0 . Next let P_∞ be the parahoric in the conjugacy class of $P_{\frac{1}{2}\rho^\vee}$ that contains the Iwahori $I_\infty^{\text{op}} \subset L_\infty^+G$ defined in terms of B^{op} . Finally, let $I_1 \subset L_1^+G$ denote the Iwahori subgroup defined again in terms of B . In the notation of Section 2, we now let $S = \{0, 1, \infty\} \subset \mathbb{P}^1(k)$; for later reference, we let X^0 be the variety $\mathbb{P}^1 - S$ over k . The primary object of study in [Yun 2014a] is the moduli space (see Definition 2.3)

$$\text{Bun} = \text{Bun}_G({}^{(2)}P_0, I_1, P_\infty).$$

This sits in the diagram

$$\begin{array}{ccccc} \text{Bun}^+ & \longrightarrow & \text{Bun}_G(P_0^+, P_\infty) & & \\ \downarrow & & \downarrow & \searrow & \\ \text{Bun} & \longrightarrow & \text{Bun}_G({}^{(2)}P_0, P_\infty) & \longrightarrow & \text{Bun}_G(P_0, P_\infty) \end{array} \tag{5}$$

in which $\text{Bun}^+ = \text{Bun}_G(P_0^+, I_1, P_\infty)$. The vertical maps are ${}^{(2)}K_0$ -torsors, and the square is 2-cartesian. Note too that the fibers of horizontal arrows in the square are isomorphic to the flag variety fl_G of G .

Next we modify these constructions to define the corresponding moduli stacks of \tilde{G} -bundles on X . There are various ways of doing this; we take care to choose the new level structures so that the moduli spaces in the G and \tilde{G} cases are most easily compared.

Definition 3.2. Let \tilde{P}_∞ be the subgroup scheme of $L_\infty\tilde{G}$ generated by P_∞ and $L_\infty^+(\tilde{Z}^0)$. Let $\tilde{P}_0(1)$ be the subgroup scheme of $L_0\tilde{G}$ generated by P_0 and the pro-algebraic group $\tilde{Z}^0(1)$ defined as the kernel of reduction modulo t (a local coordinate at zero),

$$\tilde{Z}^0(1) = \ker(L_0^+(\tilde{Z}^0) \rightarrow \tilde{Z}^0).$$

Note that $\tilde{\mathbf{P}}_0(1)$ is isomorphic to the direct product $\mathbf{P}_0 \times \tilde{\mathbf{Z}}^0(1)$: the restriction of ν to $\nu : \tilde{\mathbf{Z}}^0 \rightarrow S$ can be identified with a product of maps $\mathbb{G}_m \rightarrow \mathbb{G}_m$, each given by multiplication by some $n \in \{\pm 1, \pm 2\}$, so (working one coordinate at a time), for any $x \in R[[t]]$, the equation

$$1 = \nu(1 + tx) = 1 + ntx + (\text{higher order terms})$$

forces $x = 0$, since we have assumed (see (4)) that 2 is invertible in k . Moreover, the pro-unipotent radical of $\tilde{\mathbf{P}}_0(1)$ is $\mathbf{P}_0^+ \cdot \tilde{\mathbf{Z}}^0(1)$, so the maximal reductive quotient of $\tilde{\mathbf{P}}_0(1)$ is also K_0 . In particular, we can form the analogous group ${}^{(2)}\tilde{\mathbf{P}}_0(1)$ by pullback.

Finally, let $\tilde{\mathbf{I}}_1$ denote the Iwahori subgroup associated to $\tilde{\mathbf{B}}$ in $L_1^+ \tilde{\mathbf{G}}$. With this notation in place, we introduce our main object of study:

Definition 3.3. Let $\widetilde{\text{Bun}}$ denote the algebraic stack $\text{Bun}_{\tilde{\mathbf{G}}}({}^{(2)}\tilde{\mathbf{P}}_0(1), \tilde{\mathbf{I}}_1, \tilde{\mathbf{P}}_\infty)$.

Similarly setting $\widetilde{\text{Bun}}^+ = \text{Bun}_{\tilde{\mathbf{G}}}(\mathbf{P}_0^+ \cdot \tilde{\mathbf{Z}}^0(1), \tilde{\mathbf{I}}_1, \tilde{\mathbf{P}}_\infty)$, we then have the $\tilde{\mathbf{G}}$ -analogue of the basic diagram (5):

$$\begin{array}{ccccc}
 \widetilde{\text{Bun}}^+ & \longrightarrow & \text{Bun}_{\tilde{\mathbf{G}}}(\mathbf{P}_0^+ \cdot \tilde{\mathbf{Z}}^0(1), \tilde{\mathbf{P}}_\infty) & & \\
 \downarrow & & \downarrow & \searrow & \\
 \widetilde{\text{Bun}} & \longrightarrow & \text{Bun}_{\tilde{\mathbf{G}}}({}^{(2)}\tilde{\mathbf{P}}_0(1), \tilde{\mathbf{P}}_\infty) & \longrightarrow & \text{Bun}_{\tilde{\mathbf{G}}}(\tilde{\mathbf{P}}_0(1), \tilde{\mathbf{P}}_\infty)
 \end{array} \tag{6}$$

Here the vertical maps are still ${}^{(2)}K_0$ -torsors, the diagram is 2-cartesian, and again the fibers of the horizontal arrows in the square are copies of fl_G .

We now must recall the Birkhoff decomposition and uniformization results for G - (or $\tilde{\mathbf{G}}$ -) bundles on $X = \mathbb{P}^1$. Consider the “trivial G -bundle on \mathbb{A}^1 with tautological \mathbf{P}_0 -level structure” $\mathcal{P}_{\mathbb{A}^1}^0$; to be precise, $\mathcal{P}_{\mathbb{A}^1}^0$ is defined as in Section 2, and is not literally a G -bundle on \mathbb{A}^1 . Likewise, let $\tilde{\mathcal{P}}_{\mathbb{A}^1}^0$ be the trivial $\tilde{\mathbf{G}}$ -bundle on \mathbb{A}^1 with tautological $\tilde{\mathbf{P}}_0(1)$ level structure at zero. Let Γ_0 and $\tilde{\Gamma}_0$ denote the group ind-schemes of automorphisms of $\mathcal{P}_{\mathbb{A}^1}^0$ and $\tilde{\mathcal{P}}_{\mathbb{A}^1}^0$, respectively. Also let W^{aff} denote the affine Weyl group $X_\bullet(T) \rtimes W_G$, and let $\tilde{W} = X_\bullet(\tilde{T}) \rtimes W_G$ denote the Iwahori–Weyl group of $\tilde{\mathbf{G}}$. The Weyl group of the reductive quotient K_∞ of \mathbf{P}_∞ can be identified with a subgroup of W^{aff} : take the subgroup generated by simple reflections that fix the alcove of \mathbf{P}_∞ . The same holds for the reductive quotient K_0 of \mathbf{P}_0 and its Weyl group, and in both cases we write the resulting subgroup of W^{aff} as W_K .

Lemma 3.4. *There are isomorphisms of stacks*

$$[\Gamma_0 \backslash L_\infty G / \mathbf{P}_\infty] \xrightarrow{\sim} \text{Bun}_G(\mathbf{P}_0, \mathbf{P}_\infty), \tag{7}$$

$$[\tilde{\Gamma}_0 \backslash L_\infty \tilde{\mathbf{G}} / \tilde{\mathbf{P}}_\infty] \xrightarrow{\sim} \text{Bun}_{\tilde{\mathbf{G}}}(\tilde{\mathbf{P}}_0(1), \tilde{\mathbf{P}}_\infty), \tag{8}$$

and Birkhoff decompositions

$$L_\infty G(\bar{k}) = \coprod_{W_K \setminus W^{\text{aff}}/W_K} \Gamma_0(\bar{k})w\mathbf{P}_\infty(\bar{k}), \tag{9}$$

$$L_\infty \tilde{G}(\bar{k}) = \coprod_{W_K \setminus \tilde{W}/W_K} \tilde{\Gamma}_0(\bar{k})w\tilde{\mathbf{P}}_\infty(\bar{k}). \tag{10}$$

Proof. See [Yun 2014a, §3.2.2] and [Heinloth et al. 2013, Proposition 1.1]. \square

It follows easily from diagram (6) that $\pi_0(\widetilde{\text{Bun}})$ is naturally in bijection with $\pi_0(\text{Bun}_{\tilde{G}}(\tilde{\mathbf{P}}_0(1), \tilde{\mathbf{P}}_\infty))$; this is in turn in bijection (since G is simply connected) with

$$\pi_0(\text{Bun}_{\tilde{G}}) \xrightarrow{\nu} \pi_0(\text{Bun}_S) \xleftarrow{\sim} \pi_0(L_\infty S/L_\infty^+ S) \xleftarrow{\sim} X_\bullet(S).$$

We can describe the connected components of $\widetilde{\text{Bun}}$ in terms of this uniformization. First note that replacing \mathbf{P}_0 and Γ_0 with ${}^{(2)}\mathbf{P}_0$ and ${}^{(2)}\Gamma_0$, and $\tilde{\mathbf{P}}_0(1)$ and $\tilde{\Gamma}_0$ with ${}^{(2)}\tilde{\mathbf{P}}_0(1)$ and ${}^{(2)}\tilde{\Gamma}_0$, we get obvious analogues of Lemma 3.4. Then, for each $w \in W_K \setminus \tilde{W}/W_K$ we obtain an object $\tilde{\mathcal{P}}_w$ of $\text{Bun}_{\tilde{G}}({}^{(2)}\tilde{\mathbf{P}}_0(1), \tilde{\mathbf{P}}_\infty)(k)$ by gluing $\tilde{\mathcal{P}}_{\mathbb{A}^1}^0$ with $\text{Ad}(w)\tilde{\mathbf{P}}_\infty$; and we can make the corresponding construction of $\mathcal{P}_w \in \text{Bun}_G({}^{(2)}\mathbf{P}_0, \mathbf{P}_\infty)$ for $w \in W^{\text{aff}}$. The stabilizers of \mathcal{P}_w and $\tilde{\mathcal{P}}_w$ are, respectively,

$$\text{Stab}_w^G = (\Gamma_0 \cap w\mathbf{P}_\infty w^{-1}) \times_{K_0} {}^{(2)}K_0, \tag{11}$$

$$\text{Stab}_w^{\tilde{G}} = (\tilde{\Gamma}_0 \cap w\tilde{\mathbf{P}}_\infty w^{-1}) \times_{K_0} {}^{(2)}K_0. \tag{12}$$

In other words, $\text{Bun}_G({}^{(2)}\mathbf{P}_0, \mathbf{P}_\infty)$ has a stratification by substacks $[\{\mathcal{P}_w\}/\text{Stab}_w^G]$; likewise, $\text{Bun}_{\tilde{G}}({}^{(2)}\tilde{\mathbf{P}}_0(1), \tilde{\mathbf{P}}_\infty)$ has a stratification by substacks $[\{\tilde{\mathcal{P}}_w\}/\text{Stab}_w^{\tilde{G}}]$. By taking the preimages in Bun and $\widetilde{\text{Bun}}$, we obtain stratifications by substacks that we denote Bun_w (for $w \in W_K \setminus W^{\text{aff}}/W_K$) and $\widetilde{\text{Bun}}_w$ (for $w \in W_K \setminus \tilde{W}/W_K$), respectively. For $w = \lambda \rtimes w_G \in \tilde{W} = X_\bullet(\tilde{T}) \rtimes W_G$, the substack $\widetilde{\text{Bun}}_w$ lies in the component corresponding to $\nu \circ \lambda \in X_\bullet(S)$. In particular, we can identify the connected component of $\widetilde{\text{Bun}}$ containing the tautological object \mathcal{P}_1 as

$$\widetilde{\text{Bun}}^0 = \coprod_{\substack{w=\lambda \rtimes w_G \in W_K \setminus \tilde{W}/W_K \\ \lambda \in X_\bullet(\tilde{T})}} \widetilde{\text{Bun}}_w = \coprod_{w \in W_K \setminus W^{\text{aff}}/W_K} \widetilde{\text{Bun}}_w.$$

Taking the associated \tilde{G} -bundle defines a map $\text{Bun} \rightarrow \widetilde{\text{Bun}}$, and for w in $W_K \setminus W^{\text{aff}}/W_K$ it respects the above stratifications, yielding a map $\text{Bun}_w \rightarrow \widetilde{\text{Bun}}_w$. The crucial point is the following:

Proposition 3.5. *The map $\text{Bun} \rightarrow \widetilde{\text{Bun}}^0$ is an equivalence, i.e., an isomorphism of stacks.*

Proof. We check this stratum by stratum. It suffices to show that, for all w in $X_*(T) \rtimes W_G = W^{\text{aff}} \subset \widetilde{W}$, we have $\text{Stab}_w^G = \text{Stab}_w^{\widetilde{G}}$, i.e., that the natural map

$$\Gamma_0 \cap w P_\infty w^{-1} \rightarrow \widetilde{\Gamma}_0 \cap w \widetilde{P}_\infty w^{-1}$$

is an isomorphism. For a k -algebra R , an element of $(\widetilde{\Gamma}_0 \cap w \widetilde{P}_\infty w^{-1})(R)$ gives rise fppf-locally on R to an equation of the form $p_0 z_0 = w z_\infty p_\infty w^{-1}$ with $p_0 \in P_0(R)$, $z_0 \in \widetilde{Z}^0(1)(R)$, $p_\infty \in P_\infty(R)$, and $z_\infty \in L_\infty^+(\widetilde{Z}^0)$. Applying ν , we find $\nu(z_0) = \nu(z_\infty)$; but since $1 + tR[[t]] \cap R[[t^{-1}]]^\times = \{1\}$, we see that $\nu(z_0) = \nu(z_\infty) = 1$. This forces (as in the argument following Definition 3.2, by our assumption on $\text{char}(k)$) $z_0 = 1$, and $z_\infty \in P_\infty(R)$. We may as well then assume $z_\infty = 1$ (incorporating z_∞ into p_∞), and so we actually have an equality $p_0 = w p_\infty w^{-1}$ bearing witness to an element of $(\Gamma_0 \cap w P_\infty w^{-1})(R)$. This implies that

$$\Gamma_0 \cap w P_\infty w^{-1} \rightarrow \widetilde{\Gamma}_0 \cap w \widetilde{P}_\infty w^{-1}$$

is an epimorphism, and, as it is obviously injective, we are done. □

4. The eigensheaves

4A. Construction of the eigensheaves. In this section, we combine the equivalence $\text{Bun} \xrightarrow{\sim} \widetilde{\text{Bun}}^0$ of Proposition 3.5 with the analysis of the sheaf theory of Bun carried out in [Yun 2014a, Theorem 3.2] to produce our desired Hecke eigensheaves on $\widetilde{\text{Bun}}$. The key simplification arises from applying Lemma 2.5 at the point $x = 1$, where we have taken \widetilde{I}_1 level structure. In this case we identify the group Ω_1 with the stabilizer in \widetilde{W} of the alcove corresponding to the standard Iwahori \widetilde{I}_1 , and $\nu : \Omega_1 \xrightarrow{\sim} X_*(S)$ also identifies Ω_1 with $\pi_0(\widetilde{\text{Bun}})$. For $\gamma \in \Omega_1$, we denote by

$$\mathbb{T}_\gamma : \widetilde{\text{Bun}} \rightarrow \widetilde{\text{Bun}}$$

the action given by Lemma 2.5. Writing $\widetilde{\text{Bun}}^\gamma$ for the connected component corresponding to γ , we see that \mathbb{T}_γ induces isomorphisms

$$\mathbb{T}_\gamma : \widetilde{\text{Bun}}^0 \xrightarrow{\sim} \widetilde{\text{Bun}}^\gamma.$$

In particular, all connected components of $\widetilde{\text{Bun}}$ are isomorphic (compare [Heinloth et al. 2013, Corollary 1.2]).⁷ The idea is to take Yun’s construction of a perverse Hecke eigensheaf on $\text{Bun} \xrightarrow{\sim} \widetilde{\text{Bun}}^0$, and then use the (“ramified Hecke operators”) \mathbb{T}_γ to propagate the eigensheaf to the other connected components of $\widetilde{\text{Bun}}$. We begin by reviewing Yun’s construction [2014a, §3]. The tautological object in $\text{Bun}_G(P_0, P_\infty)$ (with automorphism group K_0) has preimage in Bun equivalent to

⁷Note that this is a special, and highly simplifying, feature of our particular context; for contrast, observe that the degree-0 and degree-1 connected components of Bun_{GL_2} ($X = \mathbb{P}^1$ still) are not isomorphic, since no degree-1 vector bundle has GL_2 as its automorphism group.

a quotient $[(^{(2)}K_0 \setminus \text{fl}_G)]$, for a suitable action of K_0 on fl_G (see [Yun 2014a, §3.2.4]). The group K_0 acts on fl_G with finitely many orbits, so there is a unique open orbit $U \subset \text{fl}_G$, giving open embeddings

$$[(^{(2)}K_0 \setminus U)] \subset [(^{(2)}K_0 \setminus \text{fl}_G)] \subset \text{Bun}.$$

As in [Yun 2014a, §3.2.5], we fix a point $u_0 \in U(\mathbb{Z}[1/N])$ (for some N sufficiently large, and for an integral model of U arising from extending K_0 and G to split reductive group schemes over some $\mathbb{Z}[1/M]$), and

denote by $u_0 \in U(k)$ the induced k -point

$$\text{for all } k \text{ of sufficiently large characteristic.} \tag{13}$$

This choice is in effect from now on. As an element of $U(k) \subset \text{fl}_G(k)$, u_0 corresponds to a Borel subgroup $B_0 \subset G$ over k which is in general position with respect to K_0 :

Definition 4.1. Let A denote the finite group scheme $B_0 \cap K_0$ over k . Let $(^{(2)}A)$ denote the double cover of A given by pullback along $(^{(2)}K_0 \twoheadrightarrow K_0)$.⁸ Finally, let $Z(^{(2)}A)$ denote the center of $(^{(2)}A)$.

Recall the following results [Yun 2014a, §2.6] on the structure and representation theory of the finite 2-group $(^{(2)}A(\bar{k}))$. Recall that we have set

$$\mathbb{Q}' = \begin{cases} \mathbb{Q} & \text{if } G \text{ is of type } D_{4n}, G_2, \text{ or } E_8, \\ \mathbb{Q}(\mathbf{i}) & \text{if } G \text{ is of type } A_1, D_{4n+2}, \text{ or } E_7, \end{cases} \tag{14}$$

and have also set $\mathbb{Q}'_\ell = \mathbb{Q}_\ell(\mathbf{i})$. All sheaves considered will be \mathbb{Q}'_ℓ -sheaves. In parallel to this condition on the coefficients, we impose the following restriction on the field of definition k , in effect for the rest of this paper:

$$\sqrt{-1} \in k \text{ for } G \text{ of type } A_1, D_{4m+2}, \text{ or } E_7. \tag{15}$$

Lemma 4.2. Assume k satisfies condition (15), so that Γ_k acts trivially on $Z(^{(2)}A)(\bar{k})$.

- (1) $(^{(2)}Z_G) = Z(^{(2)}A)$.
- (2) Restriction to $(^{(2)}Z_G)(\bar{k})$ gives a bijection between irreducible odd representations of $(^{(2)}A)(\bar{k})$ and odd characters of $Z(^{(2)}A)(\bar{k})$:

$$\text{Irr}_{\mathbb{Q}}(^{(2)}A(\bar{k}))_{\text{odd}} \xrightarrow{\sim} \text{Hom}(Z(^{(2)}A)(\bar{k}), \bar{\mathbb{Q}}^\times)_{\text{odd}} = \text{Hom}(Z(^{(2)}A)(\bar{k}), \mathbb{Q}'^\times)_{\text{odd}}. \tag{16}$$

- (3) If k is a finite field, local field, or number field, then for each odd $\chi : Z(^{(2)}A)(\bar{k}) \rightarrow \mathbb{Q}'^\times$ the corresponding irreducible representation V_χ of $(^{(2)}A)(\bar{k})$ descends to an irreducible representation of $(^{(2)}A)(\bar{k}) \rtimes \Gamma_k$, whose coefficients can be taken to be $\mathbb{Q}(\mathbf{i})$.

⁸Note that this is what Yun denotes \tilde{A} .

Proof. The first claim is [Yun 2014a, Lemma 2.6(2)]. The second claim is elementary: the inverse of the isomorphism (16) is given by inducing the central character, up to some multiplicity. The third claim is a variant of [Yun 2014a, Lemma 2.7], whose proof is not complete.⁹ The obstruction to descending V_χ to a representation of $({}^2\mathbf{A}(\bar{k}) \rtimes \Gamma_k)$ is a class in $H^2(\Gamma_k, \bar{\mathbb{Q}}^\times)$. This Galois cohomology group vanishes for the claimed k ; this is elementary for k finite, and for local and especially number fields it is a beautiful theorem of Tate [Serre 1977, Theorem 4]. The argument showing the descended V_χ can be defined with $\mathbb{Q}(i)$ coefficients as in [Yun 2014a, Lemma 2.7]. \square

For clarity, we collect in one place the various conditions in effect on the field of definition k :

Definition 4.3. Consider any odd central character $\chi : Z({}^2\mathbf{A})(\bar{k}) \rightarrow \mathbb{Q}^\times$, with associated irreducible representation V_χ of $({}^2\mathbf{A}(\bar{k}))$. Let k be any field satisfying conditions (13) and (15), and *moreover* for which V_χ satisfies the conclusion of Lemma 4.2(3). Then, from now on, let V_χ denote a fixed choice of descent to an irreducible representation of $({}^2\mathbf{A}(\bar{k}) \rtimes \Gamma_k)$, with $\mathbb{Q}(i)$ coefficients.

We now recall the crucial result analyzing the sheaf theory of Bun , or, in our case, $\widetilde{\text{Bun}}^0$. Throughout, for an algebraic stack \mathfrak{X} over a field k , we will write $D^b(\mathfrak{X})$ for the derived category of bounded complexes of \mathbb{Q}'_ℓ -sheaves with constructible cohomology, as in [Laszlo and Olsson 2008] (if we need to specify another field of coefficients, \mathbb{Q}_ℓ for instance, we will write $D^b(\mathfrak{X}, \mathbb{Q}_\ell)$). Recall [Yun 2014a, §3.3.1] the subcategory

$$D^b(\text{Bun})_{\text{odd}} \subset D^b(\text{Bun})$$

of odd sheaves, on which $\mu_2^{\ker} = \ker({}^2K_0 \rightarrow K_0)$ acts by the sign character. We can similarly define $D^b(\widetilde{\text{Bun}})_{\text{odd}}$, since μ_2^{\ker} is also contained in the automorphism group of every object of $\widetilde{\text{Bun}}$. For future reference, let us also note a refinement of this observation: the automorphism group of every object of $\text{Bun}_{\tilde{G}}(\tilde{P}_0(1), \tilde{I}_1, \tilde{P}_\infty)$ contains the center Z_G of G , and likewise the automorphism group of every object of $\widetilde{\text{Bun}}$ contains the double cover (pullback under $({}^2K_0 \rightarrow K_0)$) $({}^2Z_G)$ of Z_G . We can therefore decompose $D^b(\widetilde{\text{Bun}})$ into a direct sum of categories $D^b(\widetilde{\text{Bun}})_\psi$, indexed over characters $\psi : ({}^2Z_G \rightarrow \bar{\mathbb{Q}}_\ell^\times)$. We, of course, will be interested in the corresponding decomposition of $D^b(\widetilde{\text{Bun}})_{\text{odd}}$ into a direct sum over the odd characters ψ .

We recall the main result analyzing odd sheaves on Bun . Let $j : [({}^2K_0 \setminus U)] \hookrightarrow \text{Bun}$ denote the open inclusion.

⁹Namely, that argument uses the incorrect assertion that $H^2(\bar{\Gamma}, \bar{\mathbb{Q}}^\times) = 0$ for $\bar{\Gamma}$ a finite group isomorphic to a direct sum of $\mathbb{Z}/2\mathbb{Z}$ s.

Theorem 4.4 [Yun 2014a, Theorem 3.2]. *Assume G is the split simple simply connected group of type $A_1, D_{2n}, E_7, E_8,$ or G_2 . Then the restriction*

$$j^* : D^b(\text{Bun})_{\text{odd}} \rightarrow D^b([{}^{(2)}K_0 \setminus U]_{\text{odd}})$$

is an equivalence of categories with quasi-inverse given by $j_! = j_$.*

The analysis of connected components of $\widetilde{\text{Bun}}$ then implies:

Corollary 4.5. *For all $\gamma \in \Omega_1$, consider the composite*

$$j_\gamma = \mathbb{T}_\gamma \circ j : [{}^{(2)}K_0 \setminus U] \hookrightarrow \widetilde{\text{Bun}}^\gamma.$$

Then the restriction

$$j_\gamma^* : D^b(\widetilde{\text{Bun}}^\gamma)_{\text{odd}} \rightarrow D^b([{}^{(2)}K_0 \setminus U]_{\text{odd}})$$

is an equivalence with inverse $j_{\gamma,!} = j_{\gamma,}$.*

Assume k is as in Definition 4.3. We can now define the hoped-for eigensheaves on $\widetilde{\text{Bun}}$ over k , starting from Yun’s construction on Bun . Fix an odd character (recall equation (16))

$$\chi : Z({}^{(2)}A)(\bar{k}) \rightarrow \mathbb{Q}^{\times}, \tag{17}$$

to which we have associated (Lemma 4.2 and Definition 4.3) an irreducible representation V_χ of $({}^{(2)}A)(\bar{k}) \rtimes \Gamma_k$ having χ as central character. By [Yun 2014a, Lemma 3.3], $V_\chi \otimes_{\mathbb{Q}(i)} \mathbb{Q}'_\ell$ is isomorphic to the pullback under u_0 of a geometrically irreducible local system

$$\mathcal{F}_\chi \in \text{Loc}_{({}^{(2)}K_0)}(U, \mathbb{Q}'_\ell)_{\text{odd}},$$

which we view as an object of $D^b([{}^{(2)}K_0 \setminus U]_{\text{odd}})$. Yun’s eigensheaf is then, by [Yun 2014a, Theorem 4.2],

$$j_!(\mathcal{F}_\chi) = j_*(\mathcal{F}_\chi) \in D^b(\text{Bun})_{\text{odd}}.$$

Definition 4.6. Assume k is as in Definition 4.3. Let $\chi : Z({}^{(2)}A)(\bar{k}) \rightarrow \bar{\mathbb{Q}}_\ell^\times$ be any odd character. We let $A_\chi \in D^b(\widetilde{\text{Bun}})_{\text{odd}}$ be the perverse sheaf on $\widetilde{\text{Bun}}$ whose restriction A_χ^γ , for all $\gamma \in \Omega_1$, to $\widetilde{\text{Bun}}^\gamma$ is given by

$$A_\chi^\gamma = A_\chi|_{\widetilde{\text{Bun}}^\gamma} = j_{\gamma,!}\mathcal{F}_\chi = j_{\gamma,*}\mathcal{F}_\chi.$$

That is, we make the only definition compatible with the requirement that A_χ^0 be Yun’s eigensheaf, and that A_χ be eigen for the ramified Hecke operators \mathbb{T}_γ at $1 \in X$.

4B. Geometric Satake equivalence. We recall a convenient form of the geometric Satake equivalence. See [Mirković and Vilonen 2007] and [Yun 2014a, §4.1] for more background. Let \mathcal{G} be any split connected reductive group over k (\mathcal{G} will of course eventually be either G or \tilde{G}). Let $\text{Gr}_{\mathcal{G}} = L\mathcal{G}/L^+\mathcal{G}$ as usual denote the affine Grassmannian of \mathcal{G} . The main result of [Mirković and Vilonen 2007] describes the category $\text{Sat}_{\mathcal{G}}^{\text{geom}}$ of $(L^+\mathcal{G})_{\bar{k}}$ -equivariant perverse sheaves on $\text{Gr}_{\mathcal{G},\bar{k}}$ as follows: $\text{Sat}_{\mathcal{G}}^{\text{geom}}$ admits a convolution product making it a neutral Tannakian category over \mathbb{Q}_{ℓ} with fiber functor

$$H^* : \text{Sat}_{\mathcal{G}}^{\text{geom}} \rightarrow \text{Vect}_{\mathbb{Q}_{\ell}}, \quad \mathcal{K} \mapsto H^*(\text{Gr}_{\mathcal{G},\bar{k}}, \mathcal{K}). \tag{18}$$

This fiber functor induces an equivalence

$$\text{Sat}_{\mathcal{G}}^{\text{geom}} \xrightarrow{\sim} \text{Rep}(\mathcal{G}^{\vee}), \tag{19}$$

where we write \mathcal{G}^{\vee} for the (split form over \mathbb{Q}_{ℓ} of the) dual group of \mathcal{G} . We need a version of $\text{Sat}_{\mathcal{G}}^{\text{geom}}$ over k rather than \bar{k} . It is natural for us to deviate from [Yun 2014a, §4.1] and instead follow the suggestion of [Heinloth et al. 2013, Remark 2.9] and [Frenkel and Gross 2009, §2]. Recall that the simple objects of $\text{Sat}_{\mathcal{G}}^{\text{geom}}$ are given by the intersection cohomology sheaves of the affine Schubert varieties $\text{Gr}_{\mathcal{G},\leq\lambda}$. For all dominant $\lambda \in X_{\bullet}(T)$, we write

$$j_{\lambda} : \text{Gr}_{\mathcal{G},\lambda} \hookrightarrow \text{Gr}_{\mathcal{G}}$$

for the inclusion of the $L^+\mathcal{G}$ -orbit containing t^{λ} . Then by definition the intersection cohomology sheaf of the closure $\text{Gr}_{\mathcal{G},\leq\lambda}$ of $\text{Gr}_{\mathcal{G},\lambda}$ is

$$\text{IC}_{\lambda} = j_{\lambda,*} \mathbb{Q}_{\ell}[\langle 2\rho, \lambda \rangle],$$

the shift reflecting that the dimension of $\text{Gr}_{\mathcal{G},\lambda}$ is $\langle 2\rho, \lambda \rangle$. We will define $\text{Sat}_{\mathcal{G}}$ to be the full subcategory of perverse sheaves on $\text{Gr}_{\mathcal{G}}$ consisting of finite direct sums of arbitrary Tate twists $\text{IC}_{\lambda}(m)$, for all $\lambda \in X_{\bullet}(T)^+$ and $m \in \mathbb{Z}$. Note that, in contrast to [Yun 2014a, §4.1], we do not normalize the weights of the IC_{λ} to be zero; this bookkeeping device frees us from having to choose a square-root of the cyclotomic character,¹⁰ and it ensures that the local systems we eventually construct will specialize (at points of $X^0(K)$, for K/\mathbb{Q}_{ℓ} finite) to de Rham Galois representations. Adapting the argument of [Yun 2014a, §4.1] to our normalization, a result of Arkhipov and Bezrukavnikov [2009, §3] implies that $\text{Sat}_{\mathcal{G}}$ is closed under convolution: to be precise, we have

$$\text{IC}_{\lambda} * \text{IC}_{\mu} \cong \bigoplus_{\nu} \text{IC}_{\nu}(\langle \nu - \lambda - \mu, \rho \rangle)^{\oplus m_{\lambda,\mu}^{\nu}}$$

¹⁰Which of course cannot be done over $k = \mathbb{Q}$, although it is possible over many quadratic extensions of \mathbb{Q} .

for some multiplicities $m_{\lambda,\mu}^v$. Note that $\langle v - \lambda - \mu, \rho \rangle$ is an integer, since only v for which there is an inclusion of highest-weight representations $V_v \hookrightarrow V_\mu \otimes V_\lambda$, and in particular for which $\lambda + \mu - v$ lies in the root lattice, will appear on the right-hand side. We would like to combine the tensor functor

$$H_k^* : \text{Sat}_{\mathcal{G}} \rightarrow \text{Sat}_{\mathcal{G}}^{\text{geom}} \xrightarrow{H^*} \text{Rep}(\mathcal{G}^\vee) \tag{20}$$

with a mechanism for keeping track of the weight and Tate twist. Thus we define a fully faithful tensor functor

$$H_w^* : \text{Sat}_{\mathcal{G}} \rightarrow \text{Rep}(\mathcal{G}^\vee \times \mathbb{G}_m)$$

by additively extending the assignment on simple objects

$$\text{IC}_\lambda(n) \mapsto H_k^*(\text{IC}_\lambda(n)) \boxtimes (z \mapsto z^{(2\rho,\lambda)-2n}).$$

Composing with the canonical fiber functor ω of $\text{Rep}(\mathcal{G}^\vee \times \mathbb{G}_m)$, this yields a surjective homomorphism $\mathcal{G}^\vee \times \mathbb{G}_m \rightarrow \text{Aut}^\otimes(\omega \circ H_w^*)$ whose kernel

$$\left\{ (g, z) \in \mathcal{G}^\vee \times \mathbb{G}_m : \text{for all dominant } \lambda \in X_\bullet(T) \text{ and all } n \in \mathbb{Z}, \right. \\ \left. g \text{ acts on } V_\lambda \text{ by } z^{2n - \langle 2\rho, \lambda \rangle} \right\}$$

is clearly equal to the subgroup $\langle (2\rho(-1), -1) \rangle \subset \mathcal{G}^\vee \times \mathbb{G}_m$. That is, we have a tensor equivalence $\text{Sat}_{\mathcal{G}} \xrightarrow{\sim} \text{Rep}(\mathcal{G}_1^\vee)$, where (following [Frenkel and Gross 2009])

$$\mathcal{G}_1^\vee = (\mathcal{G}^\vee \times \mathbb{G}_m) / \langle (2\rho(-1), -1) \rangle. \tag{21}$$

Note that if \mathcal{G} is simply connected, then \mathcal{G}_1^\vee is isomorphic to $G^\vee \times \mathbb{G}_m$, since $2\rho(-1) = 1$.

4C. Geometric Hecke operators. We briefly recall the definition of geometric Hecke operators in our context, as well as the notion of a Hecke eigensheaf. Recall that the Hecke stack $\widetilde{\text{Hk}}$ associated to $\widetilde{\text{Bun}}$ is the category of tuples $(R, x, \mathcal{P}, \mathcal{P}', \iota)$ where:

- R is a k -algebra;
- $x \in X^0(R)$;
- \mathcal{P} and \mathcal{P}' are objects of $\widetilde{\text{Bun}}(R)$;
- ι is an isomorphism of \mathcal{P} and \mathcal{P}' away from the graph of x .

Projecting such data to (R, x, \mathcal{P}) (the map \overleftarrow{h}) or (R, x, \mathcal{P}') (the map \overrightarrow{h}) gives a correspondence diagram

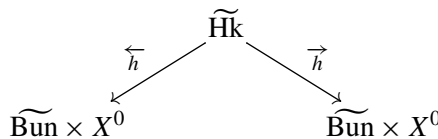

As explained in [Yun 2014a, §4.1.3] (using the fact that \overrightarrow{h} and \overleftarrow{h} are locally trivial fibrations in the smooth topology, with fibers isomorphic to $\mathrm{Gr}_{\tilde{G}}$ — see [Heinloth et al. 2013, Remark 4.1]), or slightly differently in [Yun 2013, §4.3.1], for each $\mathcal{K} \in \mathrm{Sat}_{\tilde{G}}$ there is an object $\mathcal{K}_{\mathrm{HK}} \in D^b(\mathrm{HK}, \mathbb{Q}_\ell)$ whose restriction to each geometric fiber of \overrightarrow{h} is isomorphic to \mathcal{K} . As usual, the (universal) geometric Hecke operator is the functor

$$\begin{aligned} \mathbb{T} : \mathrm{Sat}_{\tilde{G}} \times D^b(\widetilde{\mathrm{Bun}} \times X^0) &\rightarrow D^b(\widetilde{\mathrm{Bun}} \times X^0), \\ (\mathcal{K}, \mathcal{F}) &\mapsto \overrightarrow{h}_! (\overleftarrow{h}^*(\mathcal{F}) \otimes_{\mathbb{Q}_\ell} \mathcal{K}_{\mathrm{HK}}). \end{aligned} \tag{22}$$

The induced functor

$$\mathrm{Sat}_{\tilde{G}} \rightarrow \mathrm{End}(D^b(\widetilde{\mathrm{Bun}} \times X^0)) \tag{23}$$

is monoidal. When the input from $D^b(\widetilde{\mathrm{Bun}} \times X^0)$ is of the form $\mathcal{F} \boxtimes \overline{\mathbb{Q}}_\ell$ for some $\mathcal{F} \in D^b(\widetilde{\mathrm{Bun}})$, we write

$$\mathbb{T}_{\mathcal{K}}(\mathcal{F}) = \mathbb{T}(\mathcal{K}, \mathcal{F} \boxtimes \overline{\mathbb{Q}}_\ell).$$

Finally, recall the definition of a Hecke eigensheaf:

Definition 4.7. Let \mathcal{F} be an object of $D^b(\widetilde{\mathrm{Bun}})$. We say that \mathcal{F} is a Hecke eigensheaf if there exists

- a tensor functor $\tilde{\mathcal{E}} : \mathrm{Sat}_{\tilde{G}} \rightarrow \mathrm{Loc}(X^0)$;
- a system of isomorphisms, for all $\mathcal{K} \in \mathrm{Sat}_{\tilde{G}}$,

$$\epsilon_{\mathcal{K}} : \mathbb{T}_{\mathcal{K}}(\mathcal{F}) \xrightarrow{\sim} \mathcal{F} \boxtimes \tilde{\mathcal{E}}(\mathcal{K}),$$

satisfying compatibility conditions that will not concern us (see [Gaitsgory 2007, following Proposition 2.8]).

In this case we call $\tilde{\mathcal{E}}$ the eigen-local system of \mathcal{F} .

4D. Proof of the eigensheaf property. Recall that we have fixed a point

$$u_0 : \mathrm{Spec} k \rightarrow U.$$

We also write u_0 for the induced maps $\mathrm{Spec} k \rightarrow [{}^{(2)}K_0 \setminus U] \subset \widetilde{\mathrm{Bun}}^0 \subset \widetilde{\mathrm{Bun}}$. For all $\gamma \in \Omega_1$, we can compose with \mathbb{T}_γ to obtain

$$u_\gamma : \mathrm{Spec} k \rightarrow \widetilde{\mathrm{Bun}}^\gamma.$$

From Corollary 4.5, we obtain equivalences

$$(u_\gamma \times \mathrm{id})^* : D^b(\widetilde{\mathrm{Bun}}^\gamma \times X^0)_{\mathrm{odd}} \xrightarrow{\sim} D_{(2)A}(X^0)_{\mathrm{odd}}, \tag{24}$$

where $(2)A$ acts trivially on X^0 . The strategy for proving that A_χ is an eigensheaf (χ as in (17)) is to show that, for all $\gamma \in \Omega_1$ and all $\mathcal{K} \in \mathrm{Sat}_{\tilde{G}}$, $(u_\gamma \times \mathrm{id})^* \mathbb{T}_{\mathcal{K}}(A_\chi)$

is concentrated in a single perverse degree. Such sheaves A_χ can then be explicitly described via [Corollary 4.5](#) and an analogue of [[Yun 2014a](#), Lemma 3.4]. In preparation for this computation, note that the $\mathbb{T}_{\gamma,!}$ and \mathbb{T}_γ^* commute with the $\mathbb{T}_\mathcal{K}$. Informally, this is the statement that ‘‘Hecke operators at different places commute’’; more formally, the stack $\widetilde{\text{Hk}}$ carries an Ω_1 -action compatible with its two projections \overleftarrow{h} and \overrightarrow{h} . Furthermore, the spread-out sheaves $\mathcal{K}_{\widetilde{\text{Hk}}}$ (for all $\mathcal{K} \in \text{Sat}_{\widetilde{\mathcal{G}}}$) are Ω_1 -equivariant, so we find that

$$\begin{aligned} (u_\gamma \times \text{id})^* \mathbb{T}_\mathcal{K}(A_\chi) &\cong (u_0 \times \text{id})^* (\mathbb{T}_\gamma \times \text{id})^* \mathbb{T}_\mathcal{K}(A_\chi) \\ &\cong (u_0 \times \text{id})^* \mathbb{T}_\mathcal{K}(\mathbb{T}_\gamma^* A_\chi) \cong (u_0 \times \text{id})^* \mathbb{T}_\mathcal{K}(A_\chi). \end{aligned} \tag{25}$$

Now consider the following diagram, where declaring the squares cartesian defines the new objects $\widetilde{\text{GR}}$ and $\widetilde{\text{GR}}_\gamma^U$:

$$\begin{array}{ccccc} & & \widetilde{\text{GR}}_\gamma^U & \xrightarrow{j_\gamma} & \widetilde{\text{GR}} & \longrightarrow & \widetilde{\text{Hk}} \\ & \swarrow \omega_\gamma^U & & \searrow \omega & \downarrow \pi & & \downarrow \overrightarrow{h} \\ [^{(2)}K_0 \setminus U] & \xrightarrow{j_\gamma} & \widetilde{\text{Bun}} & & X^0 & \xrightarrow{u_0 \times \text{id}} & \widetilde{\text{Bun}} \times X^0 \end{array} \tag{26}$$

Here ω is the remaining projection corresponding to \overleftarrow{h} on $\widetilde{\text{Hk}}$. Note that $\widetilde{\text{GR}}$ is the analogue of the Beilinson–Drinfeld Grassmannian in this context.¹¹ Let us also denote by

$$\pi_\gamma^U : \widetilde{\text{GR}}_\gamma^U \rightarrow X^0$$

the composite $\pi \circ j_\gamma$. Repeated application of proper base change yields

$$\begin{aligned} (u_0 \times \text{id})^* \mathbb{T}_\mathcal{K}(j_{\gamma,!} \mathcal{F}_\chi) &= (u_0 \times \text{id})^* \overrightarrow{h}_! (\overleftarrow{h}^* (j_{\gamma,!} \mathcal{F}_\chi) \otimes \mathcal{K}_{\widetilde{\text{Hk}}}) \\ &\cong \pi_{\gamma,!}^U (\omega_\gamma^{U,*} (\mathcal{F}_\chi) \otimes \mathcal{K}_{\widetilde{\text{GR}}}), \end{aligned} \tag{27}$$

where $\mathcal{K}_{\widetilde{\text{GR}}}$ denotes the pullback of $\mathcal{K}_{\widetilde{\text{Hk}}}$ to $\widetilde{\text{GR}}$. The sheaf $\mathcal{K}_{\widetilde{\text{GR}}}[1]$ is perverse (recall that the fibers of $\mathcal{K}_{\widetilde{\text{GR}}}$ at $x \in X^0$ are copies of \mathcal{K}), and \mathcal{F}_χ is a local system (in cohomological degree zero), so $\omega_\gamma^{U,*} (\mathcal{F}_\chi) \otimes \mathcal{K}_{\widetilde{\text{GR}}}[1]$ is perverse. Our immediate aim is to show that each $(u_0 \times \text{id})^* \mathbb{T}_\mathcal{K}(j_{\gamma,!} \mathcal{F}_\chi)[1]$ is a perverse sheaf on X^0 . Any object \mathcal{K} of $\text{Sat}_{\widetilde{\mathcal{G}}}$ is a direct sum of simple objects, so we may assume \mathcal{K} is simple and therefore supported on some $\text{Gr}_{\widetilde{\mathcal{G}}, \leq \lambda}$, $\lambda \in X_*(\widetilde{T})$. The corresponding $\mathcal{K}_{\widetilde{\text{GR}}}$ is then supported on a corresponding substack $\widetilde{\text{GR}}_{\leq \lambda}$, which pulls back in diagram (26) to a substack $\widetilde{\text{GR}}_{\gamma, \leq \lambda}^U$ of $\widetilde{\text{GR}}_\gamma^U$.

¹¹Note that we continue to adhere to the notational pattern of using $\widetilde{(*)}$ to denote the \widetilde{G} -version of an object that could similarly be defined for G . Our notation is, as a result, not always consistent with that of [[Yun 2014a](#)]: for instance, $\widetilde{\text{GR}}^U$ denotes there (the version for G of) what we will call \mathfrak{G}^U below (see diagram (36)).

We now come to the crucial geometric lemma. We note that Yun has found [2014b, Lemma 4.4.7] an argument that applies much more generally; the following, an elaboration of [Yun 2014a, Lemma 4.8] will suffice for us.

Lemma 4.8. *For all $\gamma \in \Omega_1$, the map $\pi_\gamma^U : \widetilde{\text{Gr}}_{\gamma, \leq \lambda}^U \rightarrow X^0$ is affine.*

Proof. Since $[(^{(2)}K_0 \setminus U) \subset [^{(2)}K_0 \setminus \text{fl}_G]$ is affine, we may replace $\widetilde{\text{Gr}}_{\gamma, \leq \lambda}^U$ with the preimage of

$$[^{(2)}K_0 \setminus \text{fl}_G] \xrightarrow{j_\gamma} \widetilde{\text{Bun}}^\gamma.$$

Let us call this preimage $\widetilde{\text{Gr}}_{\gamma, \leq \lambda}^{\text{fl}}$. By construction as the preimage of $\mathbb{B}(K_0) \subset \text{Bun}_{\widetilde{G}}(\widetilde{P}_0(1), \widetilde{P}_\infty)$ (under the morphism (28) below), and using Lemma 3.1 of [Yun 2014a], $\widetilde{\text{Gr}}_{\gamma, \leq \lambda}^{\text{fl}}$ (resp. $\widetilde{\text{Gr}}_{\gamma, \leq \lambda}^{\text{fl}}$) is the nonvanishing locus of a nonzero section s of a line bundle \mathcal{L} on $\widetilde{\text{Gr}}_{\gamma}$ (resp. $\widetilde{\text{Gr}}_{\gamma, \leq \lambda}$). It suffices to show the line bundle in question is ample. By [Lazarsfeld 2004, Proposition 1.7.8], this can be checked on geometric fibers, since the morphism $\widetilde{\text{Gr}}_{\gamma, \leq \lambda} \rightarrow X^0$ is proper. Thus, let $x : \text{Spec } K \rightarrow X^0$ be a geometric point of X^0 , and consider the section x^*s of $x^*\mathcal{L}$. The fiber $\widetilde{\text{Gr}}_{\gamma, \leq \lambda, x}$ is isomorphic to the γ component, truncated by λ of the affine Grassmannian $\text{Gr}_{\widetilde{G}}$; we denote this by $\text{Gr}_{\widetilde{G}, \leq \lambda}^\gamma$. We claim that $x^*\mathcal{L}$ is ample on $\text{Gr}_{\widetilde{G}, \leq \lambda}^\gamma$, so in particular its restriction to the closed subscheme $\text{Gr}_{\widetilde{G}, \leq \lambda}^\gamma$ is ample. This claim results from the following two assertions:

- $\text{Pic}(\text{Gr}_{\widetilde{G}}^\gamma) \cong \mathbb{Z}$;
- x^*s is a nonzero global section of $x^*\mathcal{L}$ (which by the previous item must then be ample).

The first item follows from [Faltings 2003, Corollary 12]. That result shows that $\text{Pic}(\text{Gr}_G) \cong \mathbb{Z}$ (for G our simply connected group), but the same then follows for each connected component of $\text{Gr}_{\widetilde{G}}$. To be absolutely precise: consider, along with the affine Grassmannian, the affine flag variety $\text{Fl}_{\widetilde{G}} = L\widetilde{G}/\widetilde{I}$, where \widetilde{I} denotes the Iwahori. The connected components $\text{Fl}_{\widetilde{G}}^0$ and $\text{Gr}_{\widetilde{G}}^0$ are, up to taking reduced subschemes, isomorphic to their semisimple counterparts Fl_G and Gr_G (see, e.g., [Pappas and Rapoport 2008, Proposition 6.6]). As in Section 4A, the different components of $\text{Fl}_{\widetilde{G}}$ are isomorphic via ramified Hecke operators $\text{Fl}_{\widetilde{G}}^0 \xrightarrow{\mathbb{T}_\gamma} \text{Fl}_{\widetilde{G}}^\gamma$. In addition, $\text{Pic}(\text{Gr}_{\widetilde{G}}^0)$ is isomorphic to the subgroup of $\text{Pic}(\text{Fl}_{\widetilde{G}}^0)$ corresponding to the unique minimal parahoric P properly containing \widetilde{I} but not contained in $L^+\widetilde{G}$ (see the proof of [Faltings 2003, Corollary 12]); by the same argument, $\text{Pic}(\text{Gr}_{\widetilde{G}}^\gamma)$ can be described inside of $\text{Pic}(\text{Fl}_{\widetilde{G}}^\gamma)$ as the subspace spanned by the natural $\mathcal{O}(1)$ on $\mathbb{T}_\gamma(P)/\widetilde{I}$. For the second item, recall that the pair (\mathcal{L}, s) is the pullback along the composite

$$\widetilde{\text{Gr}}_\gamma \rightarrow \widetilde{\text{Bun}}^\gamma \xrightarrow{\mathbb{T}_\gamma^{-1}} \widetilde{\text{Bun}}^0 \rightarrow \text{Bun}_{\widetilde{G}}(\widetilde{P}_0(1), \widetilde{P}_\infty)^0 \xleftarrow{\sim} \text{Bun}_G(P_0, P_\infty), \quad (28)$$

where the original section is nonvanishing on the locus $\mathbb{B}K_0 \subset \text{Bun}_G(\mathbf{P}_0, \mathbf{P}_\infty)$ corresponding to the tautological object. It suffices then to show that the geometric fibers of $\widetilde{\text{GR}}_\gamma$ over $\mathbb{B}K_0 \times X^0$ are nonempty. To see this, note that $\widetilde{\text{Hk}} \rightarrow \widetilde{\text{Bun}} \times X^0$ has geometric fibers isomorphic to $\text{Gr}_{\widetilde{G}}$. Choosing an element \mathcal{P} of the fiber over (\mathcal{P}_{u_0}, x) that lies in the γ component of $\text{Gr}_{\widetilde{G}}$, we are done: the isomorphism $\iota : \mathcal{P}|_{X-\{x\}} \xrightarrow{\sim} \mathcal{P}_{u_0}|_{X-\{x\}}$ automatically implies that \mathcal{P} projects to an object isomorphic to the tautological object of $\text{Bun}_G(\mathbf{P}_0, \mathbf{P}_\infty)$. \square

With Lemma 4.8 in hand, we can prove the main result of this section:

Theorem 4.9. *For all odd characters $\chi : Z^{(2)\text{A}} \rightarrow \overline{\mathbb{Q}}_\ell^\times$, A_χ is a Hecke eigensheaf.*

Proof. Since $\omega_\gamma^{U,*}(\mathcal{F}_\chi) \otimes \mathcal{K}_{\widetilde{\text{GR}}}[1]$ is perverse, and π_γ^U is affine,

$$(u_0 \times \text{id})^* \mathbb{T}_{\mathcal{K}}(j_{\gamma,!} \mathcal{F}_\chi) \cong \pi_{\gamma,!}^U (\omega_\gamma^{U,*}(\mathcal{F}_\chi) \otimes \mathcal{K}_{\widetilde{\text{GR}}}) \in {}^p D^{\geq 1}(X^0).$$

But by Corollary 4.5, this is also

$$(u_0 \times \text{id})^* \mathbb{T}_{\mathcal{K}}(j_{\gamma,*} \mathcal{F}_\chi) \cong \pi_!(\omega^* j_{\gamma,*}(\mathcal{F}_\chi) \otimes \mathcal{K}_{\widetilde{\text{GR}}}). \tag{29}$$

There is a natural isomorphism $\omega^* \circ j_{\gamma,*} \xrightarrow{\sim} j_{\gamma,*} \circ \omega_\gamma^{U,*}$; as in the proof of [Yun 2014a, Proposition 4.7], this follows from the fact that \overleftarrow{h} is a locally trivial fibration in the smooth topology. Thus, identifying $\pi_! = \pi_*$ on the support of $\mathcal{K}_{\widetilde{\text{GR}}}$ ($\pi : \widetilde{\text{GR}}_{\leq \lambda} \rightarrow X^0$ is proper), and using the projection formula and the Leray spectral sequence, we can carry on the identification (29) as

$$(u_0 \times \text{id})^* \mathbb{T}_{\mathcal{K}}(j_{\gamma,!} \mathcal{F}_\chi) \cong \pi_*((j_{\gamma,*} \omega_\gamma^{U,*} \mathcal{F}_\chi) \otimes \mathcal{K}_{\widetilde{\text{GR}}}) \cong \pi_{\gamma,*}^U (\omega_\gamma^{U,*} \mathcal{F}_\chi \otimes \mathcal{K}_{\widetilde{\text{GR}}}). \tag{30}$$

(This is just the obvious variant of [Yun 2014a, (4.19)].) Since π_γ^U is affine, we can dually conclude that

$$(u_0 \times \text{id})^* \mathbb{T}_{\mathcal{K}}(j_{\gamma,!} \mathcal{F}_\chi) \in {}^p D^{\leq 1}(X^0), \tag{31}$$

hence that $(u_0 \times \text{id})^* \mathbb{T}_{\mathcal{K}}(j_{\gamma,!} \mathcal{F}_\chi)[1]$ is perverse. Consequently, $(u_0 \times \text{id})^* \mathbb{T}_{\mathcal{K}}(A_\chi)[1]$ is perverse.

Now, for each component $\widetilde{\text{Bun}}^\gamma$ of $\widetilde{\text{Bun}}$, we apply [Yun 2014a, Lemma 3.4] to $(u_\gamma \times \text{id})^* \mathbb{T}_{\mathcal{K}}(A_\chi)$ to conclude

$$\begin{aligned} \mathbb{T}_{\mathcal{K}}(A_\chi)|_{\widetilde{\text{Bun}}^\gamma \times X^0} &\cong \bigoplus_{\substack{\psi : Z^{(2)\text{A}} \rightarrow \overline{\mathbb{Q}}_\ell^\times \\ \psi \text{ is odd}}} (j_{\gamma,!} \mathcal{F}_\psi) \boxtimes (V_\psi^* \otimes (u_\gamma \times \text{id})^* \mathbb{T}_{\mathcal{K}}(A_\chi)_\psi)^{(2)\text{A}} \\ &= (j_{\gamma,!} \mathcal{F}_\chi) \boxtimes (V_\chi^* \otimes (u_\gamma \times \text{id})^* \mathbb{T}_{\mathcal{K}}(A_\chi))^{(2)\text{A}}, \end{aligned} \tag{32}$$

where for the second equality we use the fact that the Hecke operators $\mathbb{T}_{\mathcal{K}}$ carries the subcategory $D^b(\widetilde{\text{Bun}})_\psi$ to $D^b(\widetilde{\text{Bun}} \times X^0)_\psi$ for any $\psi : {}^{(2)}Z_G \rightarrow \overline{\mathbb{Q}}_\ell^\times$ (recall from Lemma 4.2 that $Z^{(2)\text{A}}$ is equal to the double cover ${}^{(2)}Z_G \rightarrow Z_G$ of $Z_G = Z_G[2]$).

We have already observed that $(u_\gamma \times \text{id})^* \mathbb{T}_{\mathcal{K}}(A_\chi) \cong (u_0 \times \text{id})^* \mathbb{T}_{\mathcal{K}}(A_\chi)$ is independent of γ ; we conclude that

$$\mathbb{T}_{\mathcal{K}}(A_\chi) \cong A_\chi \boxtimes (V_\chi^* \otimes (u_0 \times \text{id})^* \mathbb{T}_{\mathcal{K}}(A_\chi))^{(2)\mathbb{A}}, \tag{33}$$

and we claim that A_χ is a Hecke eigensheaf with “eigenvalue”

$$\tilde{\mathcal{E}}_\chi : \text{Sat}_{\tilde{G}} \rightarrow \text{Loc}(X^0), \quad \mathcal{K} \mapsto (V_\chi^* \otimes (u_0 \times \text{id})^* \mathbb{T}_{\mathcal{K}}(A_\chi))^{(2)\mathbb{A}}. \tag{34}$$

That is, what remains to show is that $\tilde{\mathcal{E}}_\chi(\mathcal{K})$ is in fact a local system, and that $\tilde{\mathcal{E}}_\chi$ is a tensor functor satisfying the conditions of [Definition 4.7](#). This follows (by the monoidal property of the Hecke operators) by the same argument as [\[Heinloth et al. 2013, §4.2\]](#), since we have seen that $(V_\chi^* \otimes (u_0 \times \text{id})^* \mathbb{T}_{\mathcal{K}}(A_\chi))^{(2)\mathbb{A}}$ lies in perverse degree one. \square

To summarize:

Corollary 4.10. *Assume k is as in [Definition 4.3](#). For every odd character $\chi : Z^{(2)\mathbb{A}}(\bar{k}) \rightarrow \bar{\mathbb{Q}}_\ell^\times$, the object A_χ of $D^b(\widetilde{\text{Bun}})_{\text{odd}}$ given by $A_\chi|_{\widetilde{\text{Bun}}^\gamma} = j_{\gamma,!}(\mathcal{F}_\chi)$ is a Hecke eigensheaf with eigen-local system*

$$\tilde{\mathcal{E}}_\chi : \text{Sat}_{\tilde{G}} \rightarrow \text{Loc}(X^0, \mathbb{Q}'_\ell),$$

giving rise by the Tannakian formalism to a monodromy representation (recall the notation from equation (21))

$$\tilde{\rho}_\chi : \pi_1(X^0) \rightarrow \tilde{G}_1^\vee(\mathbb{Q}'_\ell).$$

The restriction of $\tilde{\mathcal{E}}_\chi$ to the full subcategory $\text{Sat}_G \subset \text{Sat}_{\tilde{G}}$ is naturally isomorphic to the eigen-local system (there denoted \mathcal{E}'_χ) of [\[Yun 2014a, Theorem 4.2\]](#).

Moreover, if $\mathcal{K} = \text{IC}_\chi(m)$ is simple, then $\tilde{\mathcal{E}}_\chi(\mathcal{K})$ is pure of weight $\langle 2\rho, \lambda \rangle - 2m$.

Proof. We have established everything except the purity claim, which follows from the argument of [Theorem 4.9](#). Namely, equations (29) and (30) imply that $\tilde{\mathcal{E}}_\chi(\mathcal{K})$ is mixed of weights \leq and $\geq \langle 2\rho, \lambda, \cdot \rangle - 2m$ (by [\[Deligne 1980\]](#)). \square

Consequently, we have a commutative diagram

$$\begin{array}{ccc} & & \tilde{G}_1^\vee(\mathbb{Q}'_\ell) \\ & \nearrow \tilde{\rho}_\chi & \downarrow \\ \pi_1(X^0) & \xrightarrow{\rho_\chi} & G_1^\vee(\mathbb{Q}'_\ell) \end{array}$$

in which ρ_χ (of course, these monodromy representations are only well-defined up to \tilde{G}^\vee or G^\vee conjugation) is Yun’s local system.

5. The motives

Having established the Hecke eigensheaf property, we can now describe the local systems $\tilde{\mathcal{E}}_\chi(\mathcal{K})$ for all $\mathcal{K} \in \text{Sat}_{\tilde{\mathcal{G}}}$. We continue to assume k is as in Definition 4.3; in particular, the k -group scheme $Z^{(2)}(\mathbf{A})$ is discrete. Let us fix a dominant weight $\lambda \in X^\bullet(\tilde{T}^\vee) = X_\bullet(\tilde{T})$, and restrict to the case of $\mathcal{K} = \text{IC}_\lambda$. In this case the sheaf $\mathcal{K}_{\tilde{\text{Hk}}}$ is supported on a substack $\tilde{\text{Hk}}_{\leq \lambda}$, and the sheaf

$$\overleftarrow{h}^*(A_\chi^0) \otimes \mathcal{K}_{\tilde{\text{Hk}}}$$

is supported on the locus of $(\mathcal{P}, \mathcal{P}', x, \iota)$, where $\mathcal{P} \in \widetilde{\text{Bun}}^0$ and \mathcal{P} and \mathcal{P}' are in relative position $\leq \lambda$, i.e., $\text{ev}(\mathcal{P}, \mathcal{P}', \iota, x)$ lies in the $\leq \lambda$ strata of $[(L^+\tilde{G} \backslash L\tilde{G} / L^+\tilde{G}) / \text{Aut}_{\mathcal{O}}]$. This forces \mathcal{P}' to lie in the component $\widetilde{\text{Bun}}^{\nu\lambda}$, where, recall, $\nu : \tilde{G} \rightarrow S$ is the multiplier character. It follows that to compute $\mathbb{T}_{\mathcal{K}}(A_\chi^0)$ we can restrict $\overleftarrow{h} : \tilde{\text{Hk}}_{\leq \lambda} \rightarrow \widetilde{\text{Bun}}$ to the preimage of $\widetilde{\text{Bun}}^0$, and thus consider instead the correspondence diagram

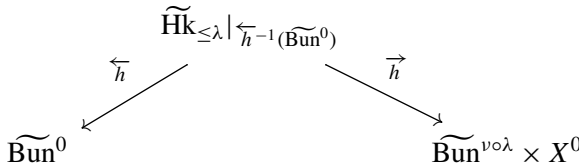

In terms of this diagram, we find that

$$\mathbb{T}_{\mathcal{K}}(A_\chi^0) \simeq A_\chi^{\nu\lambda} \boxtimes \tilde{\mathcal{E}}_\chi(\mathcal{K}). \tag{35}$$

Recall that we are trying to describe $\tilde{\mathcal{E}}_\chi(\mathcal{K})$. The argument is that of [Yun 2014a, Lemma 4.3], except we have to keep track of the different connected components. Pulling back (35) by $(u_{\nu\lambda} \times \text{id})$, we obtain, just as in (26) and (27), a diagram with cartesian squares

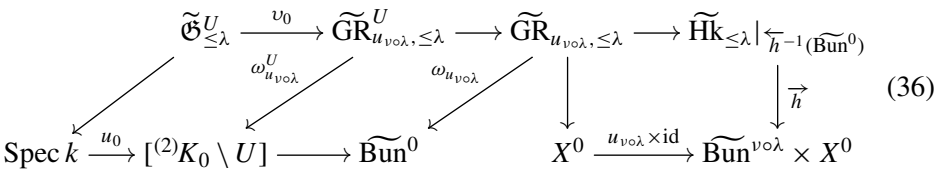

and, letting $\pi_{u_{\nu\lambda}}^U$ denote the composite map $\widetilde{\text{GR}}_{u_{\nu\lambda}, \leq \lambda}^U \rightarrow X^0$, we obtain an identification

$$V_\chi \otimes \tilde{\mathcal{E}}_\chi(\mathcal{K}) \cong (u_{\nu\lambda} \times \text{id})^* \mathbb{T}_{\mathcal{K}}(A_\chi^0) \cong \pi_{u_{\nu\lambda}}^U \left(\omega_{u_{\nu\lambda}}^{U,*}(\mathcal{F}_\chi) \otimes \mathcal{K}_{\widetilde{\text{GR}}} \right). \tag{37}$$

(We will write $\mathcal{K}_{\widetilde{\text{GR}}}$ for the pullback of $\mathcal{K}_{\tilde{\text{Hk}}}$ to either of $\widetilde{\text{GR}}_{u_{\nu\lambda}, \leq \lambda}$ or $\widetilde{\text{GR}}_{u_{\nu\lambda}, \leq \lambda}^U$.) Also let

$$\pi_{\tilde{\mathfrak{G}}_{\leq \lambda}}^U : \tilde{\mathfrak{G}}_{\leq \lambda}^U \rightarrow X^0$$

denote the corresponding projection. We now exploit the fact that $\tilde{\mathfrak{S}}_{\leq \lambda}^U$ carries a $({}^{(2)}\mathbf{A} \times ({}^{(2)}\mathbf{A}))$ -action; for clarity, the first copy, acting via the pullback on the \overleftarrow{h} (or as here, $\omega_{u_{\nu\circ\lambda}}$) projection, will be denoted $({}^{(2)}\mathbf{A}(1)$, and the second copy, acting via pullback on the \overrightarrow{h} projection, will be denoted $({}^{(2)}\mathbf{A}(2)$. Decomposing the regular representation of $({}^{(2)}\mathbf{A}$, we obtain a $({}^{(2)}\mathbf{A}(1)$ -equivariant isomorphism

$$(\nu_{0,*}\mathbb{Q}'_{\ell})_{\text{odd}} \cong \bigoplus_{\substack{\chi: Z({}^{(2)}\mathbf{A}) \rightarrow \overline{\mathbb{Q}}_{\ell}^{\times} \\ \chi \text{ is odd}}} V_{\chi}^* \otimes \omega_{u_{\nu\circ\lambda}}^{U,*} \mathcal{F}_{\chi}.$$

Here $({}^{(2)}\mathbf{A}(1)$ acts on V_{χ}^* . Since the isomorphism (37) is $({}^{(2)}\mathbf{A}(2)$ -equivariant (acting on V_{χ} on the left-hand side, and on the right-hand side since $\mathcal{K}_{\overline{\text{GR}}}$ is the pullback of $\mathcal{K}_{\overline{\text{HK}}}$), we obtain a $({}^{(2)}\mathbf{A} \times ({}^{(2)}\mathbf{A})$ -equivariant isomorphism

$$\begin{aligned} (\pi_{\tilde{\mathfrak{S}}_{\leq \lambda}^U, !} \nu_0^* \mathcal{K}_{\overline{\text{GR}}})_{\text{odd}} &\cong (\pi_{u_{\nu\circ\lambda}, !}^U \nu_{0,!} (\nu_0^* \mathcal{K}_{\overline{\text{GR}}}))_{\text{odd}} \\ &\cong \bigoplus_{\substack{\chi: Z({}^{(2)}\mathbf{A}) \rightarrow \overline{\mathbb{Q}}_{\ell}^{\times} \\ \chi \text{ is odd}}} V_{\chi}^* \otimes \pi_{u_{\nu\circ\lambda}, !}^U (\omega_{u_{\nu\circ\lambda}}^{U,*} \mathcal{F}_{\chi} \otimes \mathcal{K}_{\overline{\text{GR}}}) \\ &\cong \bigoplus_{\substack{\chi: Z({}^{(2)}\mathbf{A}) \rightarrow \overline{\mathbb{Q}}_{\ell}^{\times} \\ \chi \text{ is odd}}} V_{\chi}^* \otimes V_{\chi} \otimes \tilde{\mathcal{E}}_{\chi}(\mathcal{K}). \end{aligned} \tag{38}$$

Writing $\mathbb{Q}'_{\ell}[({}^{(2)}\mathbf{A})_{\chi}]$ for the $({}^{(2)}\mathbf{A} \times ({}^{(2)}\mathbf{A})$ -equivariant local system on $\text{Spec } k$ corresponding to the representation $V_{\chi}^* \otimes V_{\chi}$ of the group

$$({}^{(2)}\mathbf{A}(\bar{k}) \times ({}^{(2)}\mathbf{A}(\bar{k})) \rtimes \Gamma_{\bar{k}},^{12}$$

we summarize what we have shown (compare [Yun 2014a, Lemma 4.3]):

Lemma 5.1. *There is a canonical isomorphism of $({}^{(2)}\mathbf{A} \times ({}^{(2)}\mathbf{A})$ -equivariant local systems on X^0*

$$(\pi_{\tilde{\mathfrak{S}}_{\leq \lambda}^U, !} \nu_0^* \mathcal{K}_{\overline{\text{GR}}})_{\text{odd}} \cong \bigoplus_{\substack{\chi: Z({}^{(2)}\mathbf{A}) \rightarrow \overline{\mathbb{Q}}_{\ell}^{\times} \\ \chi \text{ is odd}}} \mathbb{Q}'_{\ell}[({}^{(2)}\mathbf{A})_{\chi}] \otimes \tilde{\mathcal{E}}_{\chi}(\mathcal{K}). \tag{39}$$

In particular, the left-hand side is a local system.

It is explained in [Yun 2014a, §3.3.4] how to take the invariants of an equivariant perverse sheaf under a (not necessarily discrete) finite group scheme. Applying this we have:

¹²Equivalently, regarding $\mathbb{Q}'_{\ell}[({}^{(2)}\mathbf{A}(\bar{k}))]$ as a $({}^{(2)}\mathbf{A}(\bar{k}) \times ({}^{(2)}\mathbf{A}(\bar{k}))$ -module via $(a_1, a_2) \cdot a = a_1 a a_2^{-1}$, and extracting the constituent where $Z({}^{(2)}\mathbf{A}(2))$ acts by χ .

Corollary 5.2. *For all $\mathcal{K} \in \text{Sat}_{\tilde{G}}$ and all odd $\chi : Z({}^{(2)}\mathbf{A}) \rightarrow \overline{\mathbb{Q}}_\ell^\times$, there is an isomorphism of local systems on X^0*

$$\tilde{\mathcal{E}}_\chi(\mathcal{K}) \cong (\mathbb{Q}'_\ell[{}^{(2)}\mathbf{A}]_\chi^* \otimes (\pi_{\tilde{\mathfrak{S}}_{\underline{u}_\lambda}, !} \nu_0^* \mathcal{K}_{\text{GR}})_{\text{odd}})^{{}^{(2)}\mathbf{A} \times {}^{(2)}\mathbf{A}}.$$

6. The case of minuscule weights

We now want to make this description of $\tilde{\mathcal{E}}_\chi(\mathcal{K})$ explicit. Our ultimate goal is the following:

Theorem 6.1. *Let k be \mathbb{Q} or $\mathbb{Q}(\sqrt{-1})$ according to whether G is of type D_{4n} , G_2 , E_8 or A_1 , D_{4n+2} , E_7 . Consider any odd $\chi : Z({}^{(2)}\mathbf{A}) \rightarrow \overline{\mathbb{Q}}_\ell^\times$ and any $\mathcal{K} \in \text{Sat}_{\tilde{G}}$. Let F be any number field containing k . Then, for any point $t \in X^0(F)$, the specialization*

$$\tilde{\rho}_{\chi, \mathcal{K}, t} : \pi_1(\text{Spec } F) \xrightarrow{t} \pi_1(X^0) \xrightarrow{\tilde{\rho}_\chi} \tilde{G}_1^\vee(\mathbb{Q}'_\ell) \rightarrow \text{GL}(H_w^*(\mathcal{K}))$$

(where the representation of \tilde{G}_1^\vee is that induced by \mathcal{K} under the Satake isomorphism, as in Section 4B) is, as an Γ_F -representation, isomorphic to the \mathbb{Q}'_ℓ -realization of an object of $\mathcal{M}_{F, \mathbb{Q}'}$.

The case of \mathcal{K} corresponding to a quasiminuscule weight is considered in [Yun 2014a, §4.3]. Although our discussion is valid for any \tilde{G} as in Section 3, there are certain cases in which it is uninteresting: for instance, if $G = \text{SL}_2$, we gain nothing by taking $\tilde{G} = \text{SL}_2 \times \mathbb{G}_m$; however, by taking $\tilde{G} = \text{GL}_2$, we gain the representations of $\text{SL}_2 = G_{\text{sc}}^\vee$ (the simply connected cover of G^\vee), and it is these new representations that will be of interest. Just as in the classical setting, the Kuga–Satake abelian variety is found via the spin representation of Spin_{21} , while the motive of the K3 arises from the standard 21-dimensional representation.

To show that $\tilde{\rho}_{\chi, \mathcal{K}, t}$ arises from an object of $\mathcal{M}_{F, \mathbb{Q}'}$ demands a significant digression into understanding intersection cohomology of varieties with arbitrarily bad singularities. A good first approximation to understanding the motivic nature of $\tilde{\rho}_{\chi, t} : \Gamma_F \rightarrow \tilde{G}_1^\vee(\mathbb{Q}'_\ell)$ is to verify this after composition with a single faithful finite-dimensional representation of \tilde{G}_1^\vee (i.e., to show $\tilde{\rho}_{\chi, t}$ is weakly motivic in the sense of Definition 1.2). That is what we will do in this section.

First, we make a robust choice of \tilde{G} , such that \tilde{G}^\vee has representations restricting to each of the minuscule representations of G_{sc}^\vee . For instance, we can take:

- (A_1) $\tilde{G} = \text{GL}_2$.
- (E_7) Let c denote the nontrivial element of $Z_G = \mu_2$. Then take

$$\tilde{G} = (G \times \mathbb{G}_m) / \langle (c, -1) \rangle.$$

- (D_n , n even) Let c and z be generators of $Z_G \cong \mu_2 \times \mu_2$. Then take

$$\tilde{G} = (G \times \mathbb{G}_m \times \mathbb{G}_m) / \langle (c, -1, 1), (z, 1, -1) \rangle.$$

Each minuscule representation of $G_{\text{sc}}^{\vee 13}$ extends to an irreducible representation of \widetilde{G}^{\vee} , and then to an irreducible representation of \widetilde{G}_1^{\vee} . Taking a direct sum, we obtain a faithful family of representations

$$r_{\min} : \widetilde{G}_1^{\vee} \rightarrow \text{GL}(V_{\min}), \tag{40}$$

and set ourselves the goal of showing that each $r_{\min} \circ \tilde{\rho}_{\chi,t}$ is motivated. The full force of [Theorem 6.1](#) is considerably deeper (it is new even in Yun’s original setting), so in the present section we will only treat the case of these minuscule weights, which has the added advantage that the relevant geometry — of the corresponding affine Schubert varieties — is especially simple.

We begin, however, with some generalities: continue to let $\mathcal{K} \in \text{Sat}_{\widetilde{G}}$ be any irreducible object of the form $\mathcal{K} = \text{IC}_{\lambda}$, $\lambda \in X^*(\widetilde{T}^{\vee})$ (the discussion will apply equally well to \mathcal{K} of the form $\text{IC}_{\lambda}(m)$, but we take $m = 0$ to simplify the notation). What we denoted above by $\mathcal{K}_{\widetilde{\text{GR}}[1]}$ is the intersection complex of $\widetilde{\text{GR}}_{u_{v\circ\lambda}, \leq \lambda}^U$ (or the same before restricting to U). Since the map

$$v_0 : \widetilde{\mathfrak{G}}_{\leq \lambda}^U \rightarrow \widetilde{\text{GR}}_{u_{v\circ\lambda}, \leq \lambda}$$

is étale, $v_0^* \mathcal{K}_{\widetilde{\text{GR}}[1]}$ is again the intersection complex of $\widetilde{\mathfrak{G}}_{\leq \lambda}^U$. Recall that the stratification of the affine Grassmannian induces one for the Beilinson–Drinfeld Grassmannian:

$$\widetilde{\text{GR}}_{u_{v\circ\lambda}, \leq \lambda} = \coprod_{\substack{\mu \leq \lambda \\ \mu \text{ dominant}}} \widetilde{\text{GR}}_{u_{v\circ\lambda}, \mu}.$$

The terms on the right-hand side are defined by replacing $\widetilde{\text{Hk}}_{\leq \lambda}$ by $\widetilde{\text{Hk}}_{\mu}$ in [\(36\)](#). Note that $v \circ \mu = v \circ \lambda$ since $\lambda - \mu \in X_*(T)$ lies in the coroot lattice of G . The dense open locus $\widetilde{\text{GR}}_{u_{v\circ\lambda}, \lambda}$ is smooth over X^0 : fiberwise it is the smooth stratum $\text{Gr}_{\widetilde{G}, \lambda}$ of $\text{Gr}_{\widetilde{G}, \leq \lambda}$. We write $\widetilde{\mathfrak{G}}_{\lambda}^U$ and $\widetilde{\mathfrak{G}}_{< \lambda}^U$ for the preimages in $\widetilde{\mathfrak{G}}_{\leq \lambda}^U$ of $\widetilde{\text{GR}}_{u_{v\circ\lambda}, \lambda}$ and $\coprod_{\mu < \lambda} \widetilde{\text{GR}}_{u_{v\circ\lambda}, \mu}$.

Taking the t -fiber ($t \in X^0(F)$) of the isomorphism in [Lemma 5.1](#), we obtain a (quasi-)isomorphism

$$\text{IH}_c(\widetilde{\mathfrak{G}}_{\leq \lambda, t}^U)_{\text{odd}} \cong \bigoplus_{\chi \text{ odd}} \mathbb{Q}'_{\ell}[(2)\mathbf{A}]_{\chi} \otimes \tilde{\rho}_{\chi, \mathcal{K}, t}. \tag{41}$$

Let us explain the notation. For any irreducible variety Y over a field F , the intersection complex IC_Y is a perverse sheaf in cohomological degrees $[-\dim Y, 0]$. It is pure of weight $\dim Y$. We denote by $\text{IH}_c(Y)$ the complex $R\Gamma_c(\text{IC}_Y)$ on $\text{Spec } F$; it lies in cohomological degrees $[-\dim Y, \dim Y]$, and is pure of weights $\leq \dim Y$. As usual, we then define the compactly supported intersection cohomology $\text{IH}_c^i(Y_{\overline{F}})$

¹³These are, in the three cases: the standard representation of SL_2 , the 56-dimensional representation of E_7 , and the standard ($2n$ -dimensional) and two half-spin representations of Spin_{2n} .

(a Γ_F -representation) as $H^{i-\dim Y}(\mathrm{IH}_c(Y))$ (note the degree shift). We also observe that while (compactly supported) intersection cohomology is not in general functorial for (proper) morphisms of varieties, it is for (proper) étale morphisms: $\mathrm{IC}_{\tilde{\mathfrak{G}}_{\leq \lambda, t}^U}$ is still $({}^{(2)}\mathbb{A} \times {}^{(2)}\mathbb{A})$ -equivariant, as is the isomorphism (41). Now as in [Yun 2014a, §4.3.2], we let $e_\chi \in \mathbb{Q}'[{}^{(2)}\mathbb{A}(\bar{k}) \times {}^{(2)}\mathbb{A}(\bar{k})]^{\Gamma_k}$ be the idempotent whose action on the $({}^{(2)}\mathbb{A}(\bar{k}) \times {}^{(2)}\mathbb{A}(\bar{k}))$ -module $\mathbb{Q}'[{}^{(2)}\mathbb{A}(\bar{k})]$ projects to the component $\mathbb{Q}'[{}^{(2)}\mathbb{A}]_\chi$ and then onto the line spanned by $\mathrm{id} \in \mathrm{End}(V_\chi)$ (a direct factor of the representation $\mathbb{Q}'[{}^{(2)}\mathbb{A}]_\chi$ after restricting to the diagonal copy $({}^{(2)}\mathbb{A}(\bar{k}) \hookrightarrow {}^{(2)}\mathbb{A}(\bar{k}) \times {}^{(2)}\mathbb{A}(\bar{k}))$). Explicitly,

$$e_\chi = \frac{1}{|{}^{(2)}\mathbb{A}(\bar{k}) \times {}^{(2)}\mathbb{A}(\bar{k})|} \sum_{(a_1, a_2)} \theta_\chi(a_1 a_2^{-1})(a_1, a_2),$$

where θ_χ denotes the character of the $({}^{(2)}\mathbb{A}(\bar{k}))$ -representation V_χ .

Proposition 6.2. *Let $\mathcal{K} = \mathrm{IC}_\lambda \in \mathrm{Sat}_{\tilde{\mathfrak{G}}}$, let $\chi : Z({}^{(2)}\mathbb{A}) \rightarrow \bar{\mathbb{Q}}_\ell^\times$ be odd, and let $t \in X^0(F)$ for any number field F containing k . Then*

$$\tilde{\rho}_{\chi, \mathcal{K}, t} \cong \mathrm{Gr}_{(2\rho, \lambda)}^W(e_\chi \mathrm{IH}_c^{(2\rho, \lambda)}(\tilde{\mathfrak{G}}_{\leq \lambda, t}^U)).$$

Proof. Apply e_χ to equation (41), noting that the right-hand side is concentrated in degree zero. Since we have seen that $\tilde{\mathcal{E}}_\chi(\mathrm{IC}_\lambda)$ is pure of weight $(2\rho, \lambda)$, the claim is immediate. \square

Proposition 6.2 reduces Theorem 6.1 to a special case of the following general theorem:

Theorem 6.3. *Let k be a finitely generated field of characteristic zero, and let Y/k be a quasiprojective variety. Then, for all $i, r \in \mathbb{Z}$, $\mathrm{Gr}_i^W(\mathrm{IH}_c^r(Y))$ is as a Γ_k -representation isomorphic to the ℓ -adic realization of an object of \mathcal{M}_k .*

Next consider the case in which Y is acted on by a finite k -group scheme Γ . Let $e \in \bar{\mathbb{Q}}[\Gamma(\bar{k})]^{\Gamma_k}$ be an idempotent. Fix an embedding $\bar{\mathbb{Q}} \hookrightarrow \bar{\mathbb{Q}}_\ell$. Then, for all $i, r \in \mathbb{Z}$, $\mathrm{Gr}_i^W(e \mathrm{IH}_c^r(Y, \bar{\mathbb{Q}}_\ell))$ is as a Γ_k -representation isomorphic to the $(\bar{\mathbb{Q}} \hookrightarrow \bar{\mathbb{Q}}_\ell)$ -realization of an object of $\mathcal{M}_{k, \bar{\mathbb{Q}}}$.

Remark 6.4. See Section 7A for what is meant by the weight gradings Gr_\bullet^W . Note that in the application we only need the case $i = r$.

Theorem 6.3 will be proven in Corollary 8.15. For the remainder of this section, we content ourselves with showing that $\tilde{\rho}_{\chi, t}$ is weakly motivic. Thus, it suffices to assume that λ restricts to a minuscule weight of G_{sc}^\vee . In this case, $\mathrm{Gr}_{\tilde{\mathfrak{G}}, \leq \lambda} = \mathrm{Gr}_{\tilde{\mathfrak{G}}, \lambda}$ has nonsingular reduced part, so that

$$\tilde{\rho}_{\chi, \mathrm{IC}_\lambda, t} \cong \mathrm{Gr}_{(2\rho, \lambda)}^W(e_\chi H_c^{(2\rho, \lambda)}(\tilde{\mathfrak{G}}_{\lambda, t}^U)).$$

That the right-hand side is isomorphic to the ℓ -adic realization of an object of $\mathcal{M}_{F, \mathbb{Q}'}$ follows from the standard description (originating in [Deligne 1971a]) of

the weight filtration on the cohomology of a smooth variety, via the Leray spectral sequence for its inclusion into a smooth compactification with boundary given by a smooth normal crossings divisor. See [Yun 2014a, §4.3.1] or [Patrikis and Taylor 2015, discussion between Remark 2.6 and Lemma 2.7] for this equivariant version. We conclude:

Corollary 6.5. *For all choices of \tilde{G} as in Section 3, there exists a faithful finite-dimensional representation $r : \tilde{G}_1^\vee \hookrightarrow \mathrm{GL}(V_r)$ such that, for all number field specializations $\mathrm{Spec} F \xrightarrow{t} X^0$ with F satisfying condition (15),*

$$r \circ \tilde{\rho}_{\chi,t} : \Gamma_F \rightarrow \mathrm{GL}(V_r \otimes \mathbb{Q}'_\ell)$$

is isomorphic to the \mathbb{Q}'_ℓ -realization of an object of $\mathcal{M}_{F,\mathbb{Q}'}$. For all G , we may choose \tilde{G} and r such that $r|_{G_{\mathrm{sc}}^\vee}$ is isomorphic to the direct sum of all the minuscule representations of G_{sc}^\vee .

In particular, the lifts $\tilde{\rho}_{\chi,t}$ of Yun’s $\rho_{\chi,t}$ satisfy the generalized Kuga–Satake property of Definition 1.2.

7. Intersection cohomology is motivated

7A. Overview. In the remaining sections, which are logically independent of the rest of the paper, we prove Theorem 6.3. Let k be a field of characteristic zero, and fix an algebraic closure \bar{k} of k . As usual, let $\Gamma_k = \mathrm{Gal}(\bar{k}/k)$. Let Y/k be any quasiprojective variety. If Y is irreducible of dimension d_Y , we can form the ℓ -adic intersection cohomology groups

$$\mathrm{IH}^{r+d_Y}(Y) = H^r(Y_{\bar{k}}, \mathrm{IC}_Y|_{Y_{\bar{k}}}),$$

as well as their analogues with compact supports, $\mathrm{IH}_c^{r+d_Y}(Y)$. If Y is reducible, the definitions need a little more care, working component by component; see [de Cataldo 2012, §4.6] for an explanation. The intersection complex $\mathrm{IC}_{Y_{\bar{k}}}$ is Γ_k -equivariant, so Γ_k acts on $\mathrm{IH}^*(Y)$ and $\mathrm{IH}_c^*(Y)$. Since we do not assume Y is projective, these Γ_k -representations are not pure; in particular, Theorem 6.3 cannot hold for the groups $\mathrm{IH}_c^*(Y)$ themselves. Thus we first need to make sense of the weight filtration on $\mathrm{IH}_c^*(Y)$, in order even to speak of the Γ_k -representations $\mathrm{Gr}_\bullet^W \mathrm{IH}_c^*(Y)$.

There are two basic templates, one “sheaf-theoretic” and one “geometric”, for endowing the cohomology of a variety with a weight filtration. The models for the former approach are [Deligne 1980; Beilinson et al. 1982]; the models for the latter are [Deligne 1971b; 1974]. The latter approach typically depends on having resolution of singularities over the field k , and is consequently restricted to characteristic zero; but when available, it yields more robust, because more “motivic”, results. Thus we will explain, at least for k finitely generated over \mathbb{Q} , how to give

an *a priori* “sheaf-theoretic” sense to $\mathrm{Gr}_\bullet^W \mathrm{IH}^*(Y)$, but then our main aim will be to give a “geometric” construction, as part of the proof of [Theorem 6.3](#), that recovers the sheaf-theoretic definition of the Γ_k -representations $\mathrm{Gr}_\bullet^W \mathrm{IH}_c^*(Y)$. Let us begin then by recalling the sheaf-theoretic construction of a weight filtration on $\mathrm{IH}_c^*(Y)$.

Since we work with k of characteristic zero, the basic case of positive characteristic addressed in [[Deligne 1980](#); [Beilinson et al. 1982](#)] is not sufficient. But the results of those papers have been extended in a form suitable for our purposes, and indeed much more generally than we require, in [[Huber 1997](#); [Morel 2012](#)].¹⁴ Namely, the intersection complex IC_Y is a horizontal, pure perverse sheaf in the sense of [[Morel 2012](#), §2], and [[Morel 2012](#), Théorème 3.2, Proposition 6.1] implies that $\mathrm{IH}_c^*(Y)$ (likewise $\mathrm{IH}^*(Y)$) carries a unique weight filtration W_\bullet . In particular, this means that each $\mathrm{Gr}_r^W \mathrm{IH}_c^*(Y)$ is pure of weight r in the following sense: the underlying lisse sheaf on $\mathrm{Spec} k$ arises by base change from a lisse sheaf \mathcal{G} on some smooth subalgebra $A \subset k$, of finite-type over \mathbb{Z} , and with $\mathrm{Frac}(A) = k$; and for all specializations at closed points x of $\mathrm{Spec} A$, $x^*\mathcal{G}$ is pure of weight r in the usual finite field sense. This characterizing property will hold for the output of our geometric construction; this is verified step-by-step as the construction proceeds.

We now outline the approach to [Theorem 6.3](#). By Poincaré duality for intersection cohomology (which is Γ_k -equivariant), we may restrict to the case of $\mathrm{IH}^*(Y)$. First, we remark that the basic difficulty, and interest, of this problem is that both intersection cohomology and weight filtrations are *a priori* “sheaf-theoretically” defined. The theorem shows that these sheafy constructions can in fact be realized just by playing with the cohomology of smooth projective varieties. There are two, essentially orthogonal, special cases of this problem:

- Y may be smooth but nonprojective. In this case, $\mathrm{IH}^r(Y) = H^r(Y_{\bar{k}}, \mathbb{Q}_\ell)$, and the result follows from the geometric approach of [[Deligne 1971b](#)]; namely, if \bar{Y} is a smooth compactification of Y with $\bar{Y} \setminus Y$ equal to a union of smooth divisors D_α with normal crossings, then the (E_3 -degenerate) Leray spectral sequence for the inclusion $Y \subset \bar{Y}$ yields a description of $\mathrm{Gr}_\bullet^W H^r(Y_{\bar{k}}, \mathbb{Q}_\ell)$ in terms of the divisors D_α and their various (smooth, projective) intersections; see [Theorem 7.2\(3\)](#) below, for a slight rephrasing.
- Y may be projective but singular. In this case, the result, when k is algebraically closed,¹⁵ has been proven by de Cataldo and Migliorini. We briefly describe the two

¹⁴The basic notions of horizontal sheaf, perverse t-structure on the “derived” category of horizontal sheaves, and weights for horizontal sheaves are developed in, respectively, Sections 1, 2, and 3 of [[Huber 1997](#)]. Morel’s paper builds on these foundations, generalizing the results of [[Huber 1997](#)] to any finitely generated k , and establishing a sort of six operations functoriality for complexes having weight filtrations.

¹⁵In this case one should work not just with ℓ -adic cohomology but also with (compatible) Betti and de Rham realizations, in order for the assertion to have any content.

crucial geometric inputs (assume for this informal description that k is algebraically closed). Let $f : X \rightarrow Y$ be a resolution of singularities. Roughly speaking, $\mathrm{IH}^*(Y)$ occurs as a “main term” in $H^*(X, \mathbb{Q}_\ell) = H^*(Y, f_*\mathbb{Q}_\ell)$ corresponding (via the decomposition theorem) to the summand of $f_*\mathbb{Q}_\ell$ in perverse degree $\dim X$ and supported along the open dense stratum (the nonsingular locus) Y^0 of Y . The first key result is that the perverse (Leray) filtration on $H^*(Y, f_*\mathbb{Q}_\ell)$ admits [de Cataldo 2012, Theorem 3.3.5] a remarkable geometric description in terms of a suitably generic “flag filtration”. The second is that the factor of $f_*\mathbb{Q}_\ell$ supported along Y^0 can, at least in cohomology, also be extracted “geometrically” — this follows from the novel approach to the decomposition theorem pioneered by de Cataldo and Migliorini in a series of papers (see [de Cataldo and Migliorini 2014, §1.3.3] for a precise statement).

Our task is to fuse these two approaches, and to get everything to work over an arbitrary (not algebraically closed) field k of characteristic zero. The chief obstruction to getting the relevant arguments of [de Cataldo and Migliorini 2014] to work over any k is that the “generic flags” mentioned above would need to be defined k -rationally. This it turns out is not so hard to achieve, using Bertini’s theorem over k and, crucially, the fact that flag varieties are rational, so that any Zariski open set over k necessarily has k -points.

Rather more complicated is integrating the approaches of [Deligne 1971b] and [de Cataldo and Migliorini 2014] in order to prove Theorem 6.3 for any quasiprojective Y . The basic difficulty is that, since motivated motives are only defined in the pure case, the argument (resting on [Deligne 1971b]) in the smooth case is not obviously “functorial in Y ”. Fortunately, it can be upgraded to one that is, using the results of [Guillén and Navarro Aznar 2002] on the existence of “weight complexes” of motivated motives whose cohomology computes $\mathrm{Gr}_\bullet^W H^*(Y)$ for any k -variety Y . We will also use a version for cohomology with compact supports — due independently to Gillet and Soulé [1996] and Guillén and Navarro, it is somewhat simpler, but not suited for describing the perverse Leray filtration as in [de Cataldo 2012], even for cohomology with compact supports. It is crucial, however, that we exploit both theories: the inductive construction of the support decomposition as in [de Cataldo and Migliorini 2014, Proposition 2.2.1] requires having motivated versions both of pullback in H^* and pullback for proper morphisms in H_c^* (note that these two kinds of pullbacks are not related by Poincaré duality; one cannot be formally reduced to the other). Once this setup is in place, however, the arguments of [de Cataldo and Migliorini 2014] go through *mutatis mutandis*. We consequently establish stronger results on finding “motivated” splittings of the perverse Leray filtration, and a motivated support decomposition, closely in parallel to the main results of [de Cataldo and Migliorini 2014] — see Theorem 8.13 and Corollary 8.14, which should be regarded as the main results of this half of the paper.

Notation 7.1. Except where we explicitly allow more general fields, from now on k will be a finitely generated field extension of \mathbb{Q} . Whenever we speak of the weight grading Gr_\bullet^W on various cohomology groups of a variety over k , the grading is unique, and can be shown to exist by [Morel 2012, Théorème 3.2, Proposition 6.1]. As before, \mathcal{M}_k denotes André’s category of motives for motivated cycles over k (with \mathbb{Q} -coefficients). For a smooth projective variety X over k , we write $H(X)$ for the canonical object of \mathcal{M}_k associated to X . Finally, given a map of varieties $f : X \rightarrow Y$, we always mean the derived functors when we write f_* , $f_!$, etc.

7B. Weight-graded motivated motives associated to smooth varieties. Here is the theorem of Guillén and Navarro Aznar, specialized to the precise statement we require:¹⁶

Theorem 7.2 (see Théorème 5.10 of [Guillén and Navarro Aznar 2002]). *Let k be a field of characteristic zero, and let Sch/k denote the category of finite-type separated k -schemes. Then there exists a contravariant functor*

$$h : \text{Sch}/k \rightarrow K^b(\mathcal{M}_k), \tag{42}$$

valued in the homotopy category of bounded complexes in \mathcal{M}_k , such that:

- (1) *If X is a smooth projective k -scheme, then $h(X)$ is naturally isomorphic to the canonical motivated motive $H(X)$ associated to X .*
- (2) *If X is a smooth projective k -scheme, and $D = \bigcup_{\alpha=1}^t D_\alpha$ is a normal crossings divisor equal to the union of smooth divisors D_α , we can form a cubical diagram of smooth projective varieties*

$$S_\bullet(D) \rightarrow X,$$

*where, for every nonempty subset $\Sigma \subset \{1, \dots, t\}$, $S_\Sigma(D)$ is the (smooth) intersection $D_\Sigma = \bigcap_{\alpha \in \Sigma} D_\alpha$, with the obvious inclusion maps $S_\Sigma(D) \rightarrow S_{\Sigma'}(D)$ whenever $\Sigma' \subset \Sigma$. Using the **covariant** functoriality arising from Gysin maps, we can then associate a cubical diagram $h_*(S_\bullet(D) \rightarrow X)$ in \mathcal{M}_k ; to be precise, $h_*(S_\Sigma(D))$ is the object of \mathcal{M}_k*

$$h(D_\Sigma)(\dim D_\Sigma),$$

with the Gysin maps $h_(S_\Sigma(D)) \rightarrow h_*(S_{\Sigma'}(D))$ whenever $\Sigma' \subset \Sigma$. Then $h(X \setminus D)$ is isomorphic to the simple complex associated to this cubical diagram (see the proof for what this means):*

$$h(X \setminus D) \cong s(h_*(S_\bullet(D) \rightarrow X))(-\dim X). \tag{43}$$

¹⁶They prove something stronger, with Chow motives in place of motivated motives.

- (3) In particular, $h(X \setminus D)$ is a complex whose degree- r homology¹⁷ $H_r(h(X \setminus D))$ is an object of \mathcal{M}_k whose ℓ -adic realization is given by (for k finitely generated over \mathbb{Q})

$$H_\ell(H_r(h(X \setminus D))) \cong \bigoplus_q \mathrm{Gr}_{q+r}^W H^q((X \setminus D)_{\bar{k}}, \mathbb{Q}_\ell).$$

Proof. Except for the third assertion, this is all explicitly in [Guillén and Navarro Aznar 2002, Théorème 5.10]. The remaining claim follows from the usual description [Deligne 1971b] of the weight gradeds for $H^*((X \setminus D)_{\bar{k}}, \mathbb{Q}_\ell)$: ignoring for notational convenience the Tate twists, the degree- r term $h(X \setminus D)_r$ (to be precise, after the identification of equation (43)) is $\bigoplus_{|\Sigma|=r} h(D_\Sigma)$, with the boundary map $h(X \setminus D)_r \rightarrow h(X \setminus D)_{r-1}$ given by an alternating sum of Gysin maps. The ℓ -adic realization of this complex can be identified (up to a sign in the boundary maps, at least — see [Guillén and Navarro Aznar 1990, (1.8) Proposition]) with the complex

$$\dots \rightarrow K_r = \bigoplus_q E_1^{-r, q+r} \xrightarrow{\bigoplus_q d_1^{-r, q+r}} K_{r-1} = \bigoplus_q E_1^{-r+1, q+r} \rightarrow \dots$$

built out of the E_1 terms of the (weight) spectral sequence of the filtered complex (bête filtration)

$$E_1^{-r, q+r} = H^q(X_{\bar{k}}, \mathrm{Gr}_r^W j_* \mathbb{Q}_\ell) \implies H^q(X_{\bar{k}}, j_* \mathbb{Q}_\ell) = H^q((X \setminus D)_{\bar{k}}, \mathbb{Q}_\ell).$$

This spectral sequence degenerates at the E_2 page (by the yoga of weights), and its E_2 terms then give the weight gradeds of $H^q((X \setminus D)_{\bar{k}}, \mathbb{Q}_\ell)$; part (3) of the theorem follows. \square

This is not a full description of the result of Guillén and Navarro Aznar, but it contains the two points of interest for us: the explicit description of the objects $H_r(h(X \setminus D))$, and in particular their connection with the weight filtration on $H^*((X \setminus D)_{\bar{k}}, \mathbb{Q}_\ell)$; and, crucially, the fact that h is functorial. In particular, for any morphism $\phi : U \rightarrow V$ in Sch/k , we get, for all r , morphisms $H_r(h(V)) \rightarrow H_r(h(U))$ in \mathcal{M}_k .

Here is the compact-supports version:

Theorem 7.3 [Gillet and Soulé 1996, Theorem 2; Guillén and Navarro Aznar 2002, Théorème 5.2]. *Let k be a field of characteristic zero, and let Sch_c/k denote the category of separated finite-type k -schemes with morphisms given by proper maps. Then there exists a contravariant functor*

$$W : \mathrm{Sch}_c/k \rightarrow K^b(\mathcal{M}_k) \tag{44}$$

such that:

¹⁷We use homological conventions here.

- (1) If X is a smooth projective k -scheme, then $W(X)$ is naturally isomorphic to the canonical motivated motive $H(X)$ associated to X .
- (2) If X is a smooth projective k -scheme, and $D = \bigcup_{\alpha=1}^t D_\alpha$ is a normal crossings divisor equal to the union of smooth divisors D_α , then $W(X \setminus D)$ is isomorphic to the simple complex (we now use cohomological conventions and normalize $W(X \setminus D)$ to live in cohomological degrees $[0, t]$)

$$H(X) \rightarrow \bigoplus_{\alpha} H(D_\alpha) \rightarrow \cdots \rightarrow \bigoplus_{|\Sigma|=s} H(D_\Sigma) \rightarrow \cdots \tag{45}$$

with coboundaries given by an alternating sum of restriction maps $H(D_{\Sigma'}) \rightarrow H(D_\Sigma)$ whenever $\Sigma' \subset \Sigma$. (See [Gillet and Soulé 1996, Proposition 3].)

- (3) In particular, $W(X \setminus D)$ is a complex whose degree- s cohomology $H^s(W(X \setminus D))$ is an object of \mathcal{M}_k whose ℓ -adic realization is given by (for k finitely generated over \mathbb{Q})

$$H_\ell(H^s(W(X \setminus D))) \cong \bigoplus_p \mathrm{Gr}_p^W H_c^{p+s}((X \setminus D)_{\bar{k}}, \mathbb{Q}_\ell).$$

In the setting of parts 2 and 3 of Theorems 7.2 and 7.3, let $U = X \setminus D$. Poincaré duality for U descends to a duality relation in \mathcal{M}_k between the cohomologies of the complexes $h(U)$ and $W(U)$. Before stating it, we introduce a little more notation:

Definition 7.4. Let $H_r^q(h(U))$ be the canonical summand of $H_r(h(U))$ in \mathcal{M}_k of weight $q + r$. Let $W^p(U)$ be the canonical complex of weight- p summands of the terms of $W(U)$, and let $H^s(W^p(U))$ be the degree- s cohomology.

Remark 7.5. The object $H_r^q(h(U))$ of \mathcal{M}_k has ℓ -adic realization $\mathrm{Gr}_{q+r}^W H^q(U_{\bar{k}}, \mathbb{Q}_\ell)$. The object $H^s(W^p(U))$ of \mathcal{M}_k has ℓ -adic realization $\mathrm{Gr}_p^W H_c^{p+s}(U_{\bar{k}}, \mathbb{Q}_\ell)$.

Lemma 7.6. Let $U = X \setminus D$ as above, and assume U is equidimensional of dimension d . Then there is a canonical isomorphism in \mathcal{M}_k

$$H_r^q(h(U))^\vee \cong H^r(W^{2d-q-r}(U))(d). \tag{46}$$

Proof. Poincaré duality for each D_Σ induces a perfect duality between $h(U)_s$ and $W(U)^s$ (the degree- s terms of each complex) for all s . The Gysin maps $H(D_{\Sigma'})(d - |\Sigma'|) \rightarrow H(D_\Sigma)(d - |\Sigma|)$ are Poincaré dual to the pullback maps $H(D_\Sigma) \rightarrow H(D_{\Sigma'})$ for all $\Sigma \subset \Sigma'$, and we can deduce perfect dualities (in \mathcal{M}_k)

$$H_s(h(U))^\vee \cong H^s(W(U))(d).$$

The result follows from decomposing these dualities into each of their graded components. □

8. The perverse Leray filtration

8A. Relation to flag filtrations. In this section we recall the beautiful and fundamental result of de Cataldo and Migliorini that describes the perverse Leray filtration for a map of varieties in terms of a certain flag filtration — see [de Cataldo and Migliorini 2010] and, for the specific result we use, Theorem 3.3.5 of [de Cataldo 2012]. These results are worked out over an algebraically closed field of characteristic zero, and so our first aim in this section is to check the analogue for any $k \supset \mathbb{Q}$.

We first recall the Jouanolou trick.

Definition 8.1. Let Y be a variety over k . An *affinement* of Y is a map $\mathcal{Y} \xrightarrow{p} Y$ in Sch/k with \mathcal{Y} an affine k -scheme, such that p is a torsor for some vector bundle on Y .

Proposition 8.2 [Jouanolou 1973, Lemme 1.5]. *Suppose $Y \in \text{Sch}/k$ is quasiprojective. Then an affinement of Y exists.*

Jouanolou’s result in fact holds for arbitrary quasiprojective schemes, but we are only interested in the case of varieties over k .

Now let $f : X \rightarrow Y$ be a morphism of k -varieties. It induces the (increasing) perverse Leray filtration on $H^*(X_{\bar{k}}, \mathbb{Q}_\ell)$ via

$$\begin{aligned} \mathcal{P}_j^f(H^*(X_{\bar{k}}, \mathbb{Q}_\ell)) &= \text{im}(H^*(Y_{\bar{k}}, {}^p\tau_{\leq j} f_* \mathbb{Q}_\ell) \rightarrow H^*(Y_{\bar{k}}, f_* \mathbb{Q}_\ell)) \\ &\subseteq H^*(Y_{\bar{k}}, f_* \mathbb{Q}_\ell) = H^*(X_{\bar{k}}, \mathbb{Q}_\ell). \end{aligned} \tag{47}$$

Here ${}^p\tau_{\leq j}$ denotes perverse truncation.¹⁸ We make the analogous definition of the perverse Leray filtration on $H_c^*(X_{\bar{k}}, \mathbb{Q}_\ell)$, replacing $f_* \mathbb{Q}_\ell$ by $f_! \mathbb{Q}_\ell$ (the only case of interest to us will be when f is proper, so $f_* = f_!$).

Theorem 8.3 [de Cataldo 2012, Theorem 3.3.5]. *Assume $k = \bar{k}$ is an algebraically closed field of characteristic zero. Let $f : X \rightarrow Y$ be a morphism in Sch/k with Y quasiprojective. Let $p : \mathcal{Y} \rightarrow Y$ be an affinement of Y of relative dimension $d(p)$,¹⁹ and choose a closed embedding $\mathcal{Y} \hookrightarrow \mathbb{A}^N$ of \mathcal{Y} into some affine space. Let*

$$\mathbb{A}_\bullet = \{\emptyset = \mathbb{A}_{-N-1} \subset \mathbb{A}_{-N} \subset \cdots \subset \mathbb{A}_0 = \mathbb{A}^N\}$$

¹⁸It is defined for the complex $f_* \mathbb{Q}_\ell$ on Y itself, and we omit the base change to \bar{k} in the notation of these cohomology groups.

¹⁹If Y is not connected, $d(p)$ is a function $\pi_0(Y) \rightarrow \mathbb{Z}$; we can always reduce to the case of connected Y , so do not dwell on this.

be a full flag of affine linear sections of \mathbb{A}^N , and form the cartesian diagram

$$\begin{array}{ccccc}
 & & r_{\bullet} & & \\
 & \curvearrowright & & \searrow & \\
 \mathcal{X}_{\bullet} & \xrightarrow{i_{\bullet}} & \mathcal{X} & \xrightarrow{p} & X \\
 \downarrow & & \downarrow & & \downarrow f \\
 \mathcal{Y}_{\bullet} & \longrightarrow & \mathcal{Y} & \xrightarrow{p} & Y \\
 \downarrow & & \downarrow & & \\
 \mathbb{A}_{\bullet} & \longrightarrow & \mathbb{A}^N & &
 \end{array} \tag{48}$$

We define the associated (increasing) flag filtrations

$$F_j^{\mathbb{A}_{\bullet}} H^*(X_{\bar{k}}, \mathbb{Q}_{\ell}) = \ker(r_{-j}^* : H^*(X_{\bar{k}}, \mathbb{Q}_{\ell}) \rightarrow H^*((\mathcal{X}_{-j})_{\bar{k}}, \mathbb{Q}_{\ell})) \tag{49}$$

and (see Remark 8.4)

$$F_j^{\mathbb{A}_{\bullet}} H_c^*(X_{\bar{k}}, \mathbb{Q}_{\ell}) = \text{im}(r_{!,j} : H_c^*((\mathcal{X}_j)_{\bar{k}}, \mathbb{Q}_{\ell}) \rightarrow H_c^*(X_{\bar{k}}, \mathbb{Q}_{\ell})). \tag{50}$$

Then, for a general flag \mathbb{A}_{\bullet} ,

$$\mathcal{P}_j^f H^q(X_{\bar{k}}, \mathbb{Q}_{\ell}) = F_{1+d(p)-q+j}^{\mathbb{A}_{\bullet}} H^q(X_{\bar{k}}, \mathbb{Q}_{\ell}) \tag{51}$$

and

$$\mathcal{P}_j^f H_c^q(X_{\bar{k}}, \mathbb{Q}_{\ell}) = F_{j-q-d(p)}^{\mathbb{A}_{\bullet}} H_c^q(X_{\bar{k}}, \mathbb{Q}_{\ell}). \tag{52}$$

Remark 8.4. (1) Let us spell out the construction of the maps $r_{!,j}$. There is a canonical identification

$$H_c^k(X_{\bar{k}}, \mathbb{Q}_{\ell}) \cong H_c^k(\mathcal{X}_{\bar{k}}, p^! \mathbb{Q}_{\ell}) \cong H_c^{k+2d(p)}(\mathcal{X}_{\bar{k}}, \mathbb{Q}_{\ell})(d(p)),$$

and then adjunction gives maps

$$H_c^k((\mathcal{X}_{-j})_{\bar{k}}, i_{-j}^! \mathbb{Q}_{\ell}) \rightarrow H_c^k(\mathcal{X}_{\bar{k}}, \mathbb{Q}_{\ell}).$$

As part of the definition of “general position”, we may assume the \mathcal{X}_{-j} are smooth, so by cohomological purity these adjunction maps are identified with (Gysin) maps

$$H_c^{k-2j}((\mathcal{X}_{-j})_{\bar{k}}, \mathbb{Q}_{\ell})(-j) \rightarrow H_c^k(\mathcal{X}_{\bar{k}}, \mathbb{Q}_{\ell}).$$

The “corestriction” maps $r_{!,-j}$ are then given by the composites

$$H_c^{k+2d(p)-2j}((\mathcal{X}_{-j})_{\bar{k}}, \mathbb{Q}_{\ell})(d(p) - j) \rightarrow H_c^{k+2d(p)}(\mathcal{X}_{\bar{k}}, \mathbb{Q}_{\ell})(d(p)) \rightarrow H_c^k(X_{\bar{k}}, \mathbb{Q}_{\ell}).$$

Important for our purposes is that these are precisely the maps Poincaré dual to the pullback maps arising from the maps $\mathcal{X}_{-j} \rightarrow X$.

(2) We need to specify what is meant by a *general* flag; this will be done in [Section 8B](#). What matters for our purposes is that there exists a Zariski open, dense subspace Flag^{gen} inside the variety Flag of full (affine linear) flags in \mathbb{A}^N such that all points $\mathbb{A}_\bullet \in \text{Flag}^{\text{gen}}(k)$ are “general”.

(3) Note that the degree shift between the perverse and flag filtrations depends on the degree (q above) of cohomology. We will ultimately work one degree of cohomology at a time, and all that matters for us is that *some* shift of the flag filtration agrees with the perverse filtration. To extract the exact degree shift $j \mapsto 1 + d(p) - q + j$, use [[de Cataldo 2012](#), Theorem 3.3.5, (3.8), Example 3.1.6, and (3.16)], and similarly for cohomology with compact supports.

We now explain why this result can be refined k -rationally, so that the diagram (48) for which the conclusion of [Theorem 8.3](#) holds can be taken to be a diagram in Sch/k . In the process, we will say more explicitly what is meant by a “general” flag in the case of *proper* $f : X \rightarrow Y$ (this case is somewhat simpler — see [[de Cataldo 2012](#), Remark 3.2.13] — and it is all we need).

8B. Stratifications. To define “general” flags, we need to say something about stratifications. From now on we will consider a proper map $f : X \rightarrow Y$ of varieties over k with Y quasiprojective. For the purposes of [Theorem 8.3](#), we need only find a stratification Σ of Y such that $f_*\mathbb{Q}_\ell$ is Σ -constructible. That is, we require a decomposition $Y = \bigsqcup_{\sigma \in \Sigma} Y_\sigma$ of Y into locally closed, irreducible, nonsingular varieties such that $f_*\mathbb{Q}_\ell|_{Y_\sigma}$ is lisse for all σ . This is easily arranged; note that the strata Y_σ may be irreducible but not geometrically connected. Then we can deduce:

Corollary 8.5. *Let k be a field of characteristic zero, and let $f : X \rightarrow Y$ be a proper morphism in Sch/k with Y quasiprojective. Then there exists a diagram (48) defined over k for which the conclusions (51) and (52) of [Theorem 8.3](#) hold.*

Proof. Choose as before an affinement $p : \mathcal{Y} \rightarrow Y$ and an embedding $\mathcal{Y} \hookrightarrow \mathbb{A}^N$, and let Flag denote the variety over k of full affine linear flags in \mathbb{A}^N . Fix a stratification Σ of Y such that $f_*\mathbb{Q}_\ell$ is Σ -constructible, and pull it back to a stratification $p^{-1}\Sigma$ of \mathcal{Y} . We then consider full flags

$$\{\mathbb{A}_{-N} \subset \cdots \subset \mathbb{A}_{-1} \subset \mathbb{A}^N\}$$

such that \mathbb{A}_{-1} intersects every stratum \mathcal{Y}_σ transversally; and, refining each $\mathbb{A}_{-1} \cap \mathcal{Y}_\sigma$ to the disjoint union of its connected components, \mathbb{A}_{-2} intersects the induced stratification of $\mathcal{Y} \cap \mathbb{A}_{-1}$ transversally; and so on, inductively. By Bertini’s theorem in exactly the form [[Jouanolou 1979](#), Théorème 6.3(2)], applied inductively to each of the (smooth) strata in each $\mathcal{Y} \cap \mathbb{A}_{-i}$, the collection of such flags defines a Zariski open (over k) dense subset $\text{Flag}^{\text{gen}} \subset \text{Flag}$. Since Flag is a rational variety (for instance, by Bruhat decomposition), and k has characteristic zero,

$\text{Flag}^{\text{gen}}(k)$ is nonempty. The corollary then follows by the proof of [de Cataldo 2012, Theorems 3.3.1 and 3.3.5]. \square

So that we can directly invoke the results of [de Cataldo and Migliorini 2014], in what follows we will make further demands on the stratification, as explained in Section 1.3.2 of that paper. For a fixed proper map $f : X \rightarrow Y$, we consider stratifications of X and Y as the disjoint unions of smooth, locally closed, irreducible (over k) subvarieties, such that every stratum of X maps smoothly and surjectively onto a stratum of Y . Organizing the strata of Y by dimension, we write $Y = \bigsqcup_{l=0}^{\dim Y} S_l$, where S_l has pure dimension l . Each S_l is a disjoint union of smooth and irreducible components of dimension l ; these irreducible components need not be geometrically irreducible, but that does not affect our arguments. We then have Zariski open (dense) subsets $U_l = \bigsqcup_{m \geq l} S_m$, and we get associated closed and open immersions $\alpha_l : S_l \hookrightarrow U_l$ (closed) and $\beta_l : U_{l+1} \hookrightarrow U_l$ (open), with $U_l = S_l \sqcup U_{l+1}$. For more background on these stratifications, see [de Cataldo and Migliorini 2005, §3.2].

8C. Motivated perverse Leray filtration. By Corollary 8.5, the perverse Leray filtrations on $H^*(X_{\bar{k}}, \mathbb{Q}_\ell)$ and $H_c^*(X_{\bar{k}}, \mathbb{Q}_\ell)$ have been Γ_k -equivariantly identified with certain flag filtrations, given in terms of maps of k -varieties $X \rightarrow \mathcal{X}_{-j}$. With an eye toward our final application, in which case $f : X \rightarrow Y$ will be a resolution of singularities of Y , we continue to assume f is proper, but also require that X is nonsingular and irreducible,²⁰ and we use Theorem 7.2, Lemma 7.6 and Corollary 8.5 to define the “perverse Leray filtration” on the motivated motives $H_r(h(X))$ and $H^s(W(X))$. Consider a diagram (48) over k for which the conclusion of Theorem 8.3 holds. Since $h : \text{Sch}/k \rightarrow K^b(\mathcal{M}_k)$ is a functor, we obtain a commutative diagram

$$\begin{array}{ccc} h(X) & \xrightarrow{r_{-i}^*} & h(\mathcal{X}_{-i}) \\ & \searrow^{r_{-i-1}^*} & \downarrow \\ & & h(\mathcal{X}_{-i-1}) \end{array}$$

in $K^b(\mathcal{M}_k)$. Recall that since \mathcal{M}_k is canonically weight-graded (it has Künneth projectors), we can apply the composite functor H_r^q given by taking cohomology H_r of this diagram and projecting to the weight- $(q + r)$ component for any $q \in \mathbb{Z}$, obtaining a commutative diagram in \mathcal{M}_k

$$\begin{array}{ccc} H_r^q(h(X)) & \xrightarrow{r_{-i}^*} & H_r^q(h(\mathcal{X}_{-i})) \\ & \searrow^{r_{-i-1}^*} & \downarrow \\ & & H_r^q(h(\mathcal{X}_{-i-1})) \end{array}$$

²⁰The irreducibility assumption is only for convenience in certain intermediate results, in which, for instance, we wish to invoke Poincaré duality without complicating the notation. Eventually, we extend component by component to the reducible case.

Recall that the ℓ -adic realization of $H_r^q(h(X))$ is (by [Theorem 7.2](#)) isomorphic to $\mathrm{Gr}_{q+r}^W H^q(X_{\bar{k}}, \mathbb{Q}_\ell)$; this accounts for the notation.

Definition 8.6. The perverse Leray filtration of $H_r^q(h(X))$ is defined to be

$$\mathcal{P}_j^f H_r^q(h(X)) = \ker \{r_{-(1+d(p)-q+j)}^* : H_r^q(h(X)) \rightarrow H_r^q(h(\mathcal{X}_{-(1+d(p)-q+j)}))\}. \quad (53)$$

The gradeds for the perverse filtration, still objects of \mathcal{M}_k , are then denoted

$$\mathrm{Gr}_j^{\mathcal{P}^f} H_r^q(h(X)) = \mathcal{P}_j^f H_r^q(h(X)) / \mathcal{P}_{j-1}^f H_r^q(h(X)).$$

Remark 8.7. Our indexing convention is somewhat different from that of de Cataldo and Migliorini (compare [\[de Cataldo and Migliorini 2005, Definition 2.2.2\]](#)).

Now, we already have a definition (equation (47)) of \mathcal{P}^f on $H^q(X_{\bar{k}}, \mathbb{Q}_\ell)$ before passing to the weight gradeds; the two versions of \mathcal{P}^f are compatible in the following sense:

Lemma 8.8. *The ℓ -adic realization $H_\ell(\mathcal{P}_j^f H_r^q(h(X)))$ is isomorphic to*

$$\mathrm{Gr}_{q+r}^W \mathcal{P}_j^f H^q(X_{\bar{k}}, \mathbb{Q}_\ell),$$

and likewise with $\mathrm{Gr}_j^{\mathcal{P}^f}$ in place of \mathcal{P}_j^f .

Proof. The ℓ -adic realization functor is exact, and the maps on cohomology induced by the morphisms $\mathcal{X}_\bullet \rightarrow X$ are strict for the associated weight filtrations, so this follows from the choice of \mathcal{X}_\bullet as in [Corollary 8.5](#). \square

We also need a “motivated” description of the perverse Leray filtration in compactly supported cohomology, i.e., a filtration by submotives on each $H^s(W^p(X))$. Taking our cue from [Remark 8.4](#), we formally define a filtration on $H_r^q(h(X))^\vee$ by

$$(H_r^q(h(X)) / \mathcal{P}_j^f H_r^q(h(X)))^\vee \subset H_r^q(h(X))^\vee, \quad (54)$$

and then invoke duality to define:

Definition 8.9. The perverse Leray filtration of $H^s(W^p(X))$ is defined to be

$$\begin{aligned} \mathcal{P}_j^f H^r(W^{2 \dim X - q - r}(X)) &= (H_r^q(h(X)) / \mathcal{P}_{-j+2 \dim X - 1}^f H_r^q(h(X)))^\vee(-\dim X) \\ &\subseteq H_r^q(h(X))^\vee(-\dim X) \xrightarrow{\sim} H^r(W^{2 \dim X - q - r}(X)). \end{aligned} \quad (55)$$

We check that this definition is compatible with the usual one in cohomology:

Lemma 8.10. *The ℓ -adic realization $H_\ell(\mathcal{P}_j^f H^r(W^{2 \dim X - q - r}(X)))$ is canonically isomorphic to*

$$\mathrm{Gr}_{2 \dim X - q - r}^W \mathcal{P}_j^f H_c^{2 \dim X - q}(X_{\bar{k}}, \mathbb{Q}_\ell),$$

and likewise with $\mathrm{Gr}_j^{\mathcal{P}^f}$ in place of \mathcal{P}_j^f .

Proof. By the description (Remark 8.4) of $r_{l,-j}$ as the map Poincaré dual to r_{-j}^* , we see that Poincaré duality for X induces a duality (here F_\bullet denotes the flag filtrations for general flags)

$$(F_j H^q(X_{\bar{k}}, \mathbb{Q}_\ell))^\vee \cong (H_c^{2 \dim X - q}(X_{\bar{k}}, \mathbb{Q}_\ell) / F_{-j} H_c^{2 \dim X - q}(X_{\bar{k}}, \mathbb{Q}_\ell))(\dim X),$$

i.e.,

$$(\mathcal{P}_{-l+2 \dim X - 1}^f H^q(X_{\bar{k}}, \mathbb{Q}_\ell))^\vee \cong (H_c^{2 \dim X - q}(X_{\bar{k}}, \mathbb{Q}_\ell) / \mathcal{P}_l^f H_c^{2 \dim X - q}(X_{\bar{k}}, \mathbb{Q}_\ell))(\dim X).$$

The lemma follows by passing to Gr_\bullet^W . □

By definition, we obtain the following duality in \mathcal{M}_k , a motivated analogue of [de Cataldo and Migliorini 2014, §1.3.3(12)]:

$$\text{Gr}_j^{\mathcal{P}^f} H^r(W^{2 \dim X - q - r}(X)) \times \text{Gr}_{-j+2 \dim X}^{\mathcal{P}^f} H_r^q(h(X)) \rightarrow \mathbb{Q}(-\dim X). \quad (56)$$

We next check a functoriality property of these motivated perverse Leray filtrations.

Lemma 8.11. *Suppose*

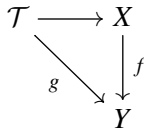

is a commutative diagram in Sch/k . Then the pullback maps $H_r^q(h(X)) \rightarrow H_r^q(h(\mathcal{T}))$ induce morphisms (in \mathcal{M}_k)

$$\mathcal{P}_j^f H_r^q(h(X)) \rightarrow \mathcal{P}_j^g H_r^q(h(\mathcal{T})).$$

If g factors as $\mathcal{T} \xrightarrow{\gamma} Z \xrightarrow{\iota} Y$ with ι a closed immersion, then the filtrations $\mathcal{P}_\bullet^\gamma$ and \mathcal{P}_\bullet^g on $H^*(\mathcal{T}_{\bar{k}}, \mathbb{Q}_\ell)$, or on $H_r^q(h(\mathcal{T}))$, coincide.

If $\mathcal{T} \rightarrow X$ is proper, then the proper pullback $H^s(W^p(X)) \rightarrow H^s(W^p(\mathcal{T}))$ also preserves the perverse Leray filtrations (55).

Proof. Since the ℓ -adic realization functor on \mathcal{M}_k is exact, it suffices to check the statement in cohomology. Here it is elementary — see for instance [de Cataldo and Migliorini 2005, Remark 4.2.3]. For the second statement, use the fact that ι_* is exact for the perverse t-structure (so commutes with perverse truncation). □

8D. Motivated support decomposition. Now we proceed as in [de Cataldo and Migliorini 2014, Proposition 2.2.1] to establish a “motivated support decomposition” of the $\text{Gr}_j^{\mathcal{P}^f} H_r^q(h(X))$, corresponding to the support decomposition of the perverse sheaf ${}^p H^j(f_* \mathbb{Q}_\ell)$. We begin by checking that the desired support decomposition exists k -rationally. Continue to let $f : X \rightarrow Y$ be our proper map of quasiprojective

varieties over k with X nonsingular. Let $Y = \bigsqcup_{l=0}^{\dim Y} S_l$ be a stratification for f as in Section 8B, with the collection of closed and open immersions

$$S_l \xrightarrow{\alpha_l} U_l \xleftarrow{\beta_l} U_{l+1}. \tag{57}$$

Lemma 8.12. *In the above setting, there is a canonical isomorphism in $\text{Perv}(Y)$*

$${}^p H^j(f_* \mathbb{Q}_\ell[\dim X]) \xrightarrow{\sim} \bigoplus_{l=0}^{\dim Y} \text{IC}_{\bar{S}_l}(\alpha_l^* H^{-l}({}^p H^j(f_* \mathbb{Q}_\ell[\dim X]))), \tag{58}$$

where the $\alpha_l^* H^{-l}({}^p H^j(f_* \mathbb{Q}_\ell[\dim X]))$ are (geometrically semisimple) local systems on S_l . Replacing α_l by the inclusion $S \xrightarrow{\iota_S} S_l \xrightarrow{\alpha_l} U_l$ of an irreducible (= connected) component S of S_l , we obtain the refined k -rational support decomposition

$${}^p H^j(f_* \mathbb{Q}_\ell[\dim X]) \xrightarrow{\sim} \bigoplus_{l=0}^{\dim Y} \bigoplus_{S \in \pi_0(S_l)} \text{IC}_{\bar{S}}((\alpha_l \circ \iota_S)^* H^{-l}({}^p H^j(f_* \mathbb{Q}_\ell[\dim X]))). \tag{59}$$

Proof. The second claim follows from the first, so we focus on establishing (58). This statement in $\text{Perv}(Y_{\bar{k}})$ is a precise form — see [de Cataldo and Migliorini 2005, Theorem 2.1.1(c)] — of the semisimplicity assertion of the decomposition theorem, so it suffices to check that the map in equation (58) can be defined in $\text{Perv}(Y)$. For notational simplicity, denote the perverse sheaf ${}^p H^j(f_* \mathbb{Q}_\ell[\dim X])$ on Y simply by K . We follow closely the argument of [de Cataldo and Migliorini 2005, Lemma 4.1.3], and, as there, the claim will follow from the following assertion: for all $l = 0, \dots, \dim Y$, there is a canonical isomorphism

$$K|_{U_l} \xrightarrow{\sim} \beta_{l,*}(K|_{U_{l+1}}) \oplus H^{-l}(K|_{U_l})[l].$$

We now explain this isomorphism, which itself follows from the corresponding geometric statement in [de Cataldo and Migliorini 2005, Lemma 4.1.3, §6]. The second projection comes from the truncation triangle

$$\tau_{\leq -l-1} K|_{U_l} \rightarrow \tau_{\leq -l} K|_{U_l} \rightarrow H^{-l} K|_{U_l}[l] \xrightarrow{\pm 1},$$

whose middle term is canonically $K|_{U_l}$, and whose right-hand term is perverse (by the support conditions in the definition of perverse sheaves; see [de Cataldo and Migliorini 2005, §4.1]).

To define the first projection, recall the successive truncation description of intermediate extension as

$$\tau_{\leq -l-1} \beta_{l,*} \beta_l^* K|_{U_l} \cong \beta_{l,*}(K|_{U_{l+1}}).$$

This suggests applying $\text{Hom}(K|_{U_l}, \cdot)$ to the truncation triangle

$$\tau_{\leq -l-1} \beta_{l*} \beta_l^* K|_{U_l} \rightarrow \tau_{\leq -l} \beta_{l*} \beta_l^* K|_{U_l} \rightarrow H^{-l}(\beta_{l*} \beta_l^* K|_{U_l})[l] \xrightarrow{\pm 1} .$$

There is a canonical map

$$K|_{U_l} \xleftarrow{\sim} \tau_{\leq -l} K|_{U_l} \longrightarrow \tau_{\leq -l} \beta_{l*} \beta_l^* K|_{U_l}$$

\curvearrowright
 a

and to construct the projection $K|_{U_l} \rightarrow \beta_{l!*}(K|_{U_{l+1}})$, it suffices to check that the image of a in

$$\text{Hom}(H^{-l}(K|_{U_l}), H^{-l}(\beta_{l*} \beta_l^* K|_{U_l})) \xrightarrow{\sim} \text{Hom}(K|_{U_l}, H^{-l}(\beta_{l*} \beta_l^* K|_{U_l})[l])$$

(recall $\tau_{\leq -l} K|_{U_l} \xrightarrow{\sim} K|_{U_l}$) is zero. But we can check whether a map of constructible sheaves on Y is zero by passing to $Y_{\bar{k}}$, so the geometric assertion [de Cataldo and Migliorini 2005, §6] implies our corresponding arithmetic assertion. \square

We have maneuvered into a position to invoke the argument of [de Cataldo and Migliorini 2014, Proposition 2.2.1] to prove:

Theorem 8.13. *Let $f : X \rightarrow Y$ be a proper map of quasiprojective varieties over k with X nonsingular. Then, for each triple of integers j, q, r , there exists a decomposition in \mathcal{M}_k*

$$\text{Gr}_j^{\mathcal{P}^f} H_r^q(h(X)) \xrightarrow{\sim} \bigoplus_{l=0}^{\dim Y} \bigoplus_{S \in \pi_0(S_l)} \text{Gr}_{j,S}^{\mathcal{P}^f} H_r^q(h(X)) \tag{60}$$

whose ℓ -adic realization is the output of applying $\text{Gr}_{q+r}^W H^q(Y_{\bar{k}}, \bullet)$ to the splitting of equation (59).²¹

The same holds for cohomology with compact supports, i.e., for the motives $\text{Gr}_j^{\mathcal{P}^f} H^s(W^p(X))$.

Proof. When X is projective, this is established in [de Cataldo and Migliorini 2014, Theorem 3.2.2], via the argument of Proposition 2.1.1 of the same paper; the impediment to that argument going through for nonprojective X is dealt with by our systematic use of the motivated motives $H_r^q(h(X))$ and $H^s(W^p(X))$. We do not repeat the proof, but we will remark on the key points. The argument proceeds by induction on $\dim X$; the inductive step is achieved by using [de Cataldo and Migliorini 2014, equations (13) and (14)] to define the summands $\text{Gr}_{j,S}^{\mathcal{P}^f} H_r^q(h(X))$ in terms of already-defined terms for lower-dimensional X . Note that it is essential that we have at our disposal motives corresponding both to cohomology without supports (the $H_r^q(h(X))$) and to cohomology with compact supports (the $H^s(W^p(X))$), with

²¹Rather, the slight relabeling of this splitting that results from replacing $f_* \mathbb{Q}_\ell[\dim X]$ in (59) with $f_* \mathbb{Q}_\ell$.

their respective pullback functorialities (Theorems 7.2 and 7.3) and the duality (Lemma 7.6 and equation (56)) relating them. \square

The corresponding result in [de Cataldo and Migliorini 2014] uses the relative hard Lefschetz theorem to obtain an absolute Hodge splitting (in the case $k = \bar{k}$) of $H^*(X_{\bar{k}}, \mathbb{Q}_\ell)$ corresponding to the full splitting of $f_*\mathbb{Q}_\ell$ given by the decomposition theorem, rather than as here merely the support decomposition in a particular perverse degree; a similar strengthening can be established in our context, which we now briefly sketch, although it is not needed for our primary goal, Theorem 6.3. For X as in the theorem, consider as usual a smooth compactification \bar{X} with $\bar{X} \setminus X = \bigcup_\alpha D_\alpha$ equal to a union of smooth divisors with normal crossings. We may assume \bar{X} is projective, and then take η to be a hyperplane line bundle arising from some projective embedding. The required motivated version of the relative hard Lefschetz theorem is that there are isomorphisms

$$\bigcup \eta^j : \mathrm{Gr}_{-j+\dim X}^{\mathcal{P}^f} H_r^q(h(X)) \xrightarrow{\sim} \mathrm{Gr}_{j+\dim X}^{\mathcal{P}^f} H_r^{q+2j}(h(X))(j). \quad (61)$$

To construct this isomorphism, note first that we can pull η back to any of the intersections $D_\Sigma = \bigcap_{\alpha \in \Sigma} D_\alpha$ and obtain a morphism of complexes $h(X) \rightarrow h(X)(1)$. This comes from the projection formula: writing η_Σ for the pullback of η to D_Σ , we have, for any inclusion $\iota : D_\Sigma \hookrightarrow D_{\Sigma'}$,

$$\iota_*(a \cup \eta_\Sigma) = \iota_*(a) \cup \eta_{\Sigma'},$$

i.e., cup-product with η commutes with the boundary (Gysin) maps of the complex $h(X)$. Passing to cohomology, η induces maps

$$\eta : H_r^q(h(X)) \rightarrow H_r^{q+2}(h(X))(1).$$

The required compatibility

$$\eta : \mathcal{P}_j^f H_r^q(h(X)) \rightarrow \mathcal{P}_{j+2}^f H_r^{q+2}(h(X))(1)$$

with the perverse filtrations follows directly from Definition 8.6. We therefore have constructed the maps appearing in (61); that they are isomorphisms, as are the corresponding maps for each term of the support decomposition, then follows as usual from the corresponding statement in cohomology. The formalism of “hard Lefschetz triples” [de Cataldo and Migliorini 2014, §1.3.4] in the abelian category \mathcal{M}_k allows us to enhance Theorem 8.13 with the following:

Corollary 8.14. *The choice of η gives rise to a distinguished splitting*

$$H_r^q(h(X)) \xrightarrow{\sim} \bigoplus_j \mathrm{Gr}_j^{\mathcal{P}^f} H_r^q(h(X))$$

of the motivated perverse Leray filtration.

Of course, \mathcal{M}_k is semisimple, so we already knew that some splitting exists. The combination of [Theorem 8.13](#) and [Corollary 8.14](#) can be regarded as a “motivated decomposition theorem”. Finally, we reach the motivating application:

Corollary 8.15 (includes [Theorem 6.3](#) above). *Let Y/k be any quasiprojective variety. Then there is an object $M \in \mathcal{M}_k$ whose ℓ -adic realization is isomorphic as a Γ_k -representation to $\mathrm{Gr}_i^W \mathrm{IH}^q(Y_{\bar{k}}, \mathbb{Q}_\ell)$. If A is a finite group scheme over k acting on Y , and $e \in \overline{\mathbb{Q}}[A(\bar{k})]^{\Gamma_k}$, then for any embedding $\overline{\mathbb{Q}} \hookrightarrow \overline{\mathbb{Q}}_\ell$ there is an object of $\mathcal{M}_{k, \overline{\mathbb{Q}}}$ whose $(\overline{\mathbb{Q}} \hookrightarrow \overline{\mathbb{Q}}_\ell)$ -realization is isomorphic as a Γ_k -representation to $\mathrm{Gr}_i^W e(\mathrm{IH}^q(Y_{\bar{k}}, \overline{\mathbb{Q}}_\ell))$.*

The same holds for intersection cohomology with compact supports.

Proof. We can assume Y is irreducible. Let $f : X \rightarrow Y$ be a resolution of singularities; X is then irreducible of dimension $\dim X$. For the motive M having ℓ -adic realization $\mathrm{Gr}_{q+r}^W \mathrm{IH}^q(Y_{\bar{k}}, \mathbb{Q}_\ell)$, we can take

$$M = \mathrm{Gr}_{\dim X, Y^{\mathrm{sm}}}^{\mathcal{P}^f} H_r^q(h(X)),$$

where Y^{sm} denotes the smooth locus of Y . (Compare [\[de Cataldo and Migliorini 2014, Remark 1.4.2\]](#), noting that we have normalized the perverse filtration differently than they do.)

For the equivariant statement, take $f : X \rightarrow Y$ to be an A -equivariant resolution of singularities; for the existence of these resolutions, including our case in which A is not necessarily a discrete group scheme, see, e.g., [\[Kollár 2005, Proposition 9.1\]](#). By [Lemma 8.11](#), each $\gamma \in \Gamma(\bar{k})$ induces an automorphism of $\mathrm{Gr}_{\dim X}^{\mathcal{P}^f} H_r^q(h(X_{\bar{k}}))$. For $e \in \overline{\mathbb{Q}}[A(\bar{k})]^{\Gamma_k}$, we obtain (after extending scalars to $\overline{\mathbb{Q}}$) an endomorphism of $\mathrm{Gr}_{\dim X}^{\mathcal{P}^f} H_r^q(h(X))$. That this endomorphism preserves the canonical submotive ([Theorem 8.13](#))

$$\mathrm{Gr}_{\dim X, Y^{\mathrm{sm}}}^{\mathcal{P}^f} H_r^q(h(X)) \subset \mathrm{Gr}_{\dim X}^{\mathcal{P}^f} H_r^q(h(X))$$

is then verified by checking the corresponding statement for ℓ -adic realizations.

The statement for compact supports follows similarly, or by now invoking Poincaré duality. □

Remark 8.16. (1) The motive underlying $\mathrm{Gr}_i^W \mathrm{IH}^k(Y_{\bar{k}}, \mathbb{Q}_\ell)$ is canonical in the following sense. The only ambiguity in its construction is that we may take a second resolution $f' : X' \rightarrow Y$ before applying the argument of [Corollary 8.15](#). But any two resolutions of singularities can be dominated by a third, and so the functoriality property of [Lemma 8.11](#) implies that by passing through this third resolution we can deduce an isomorphism in \mathcal{M}_k

$$\mathrm{Gr}_{\dim X, Y^{\mathrm{sm}}}^{\mathcal{P}^f} H_r^q(h(X)) \cong \mathrm{Gr}_{\dim X', Y^{\mathrm{sm}}}^{\mathcal{P}^f} H_r^q(h(X')).$$

To be precise, if we take a resolution $f'' : X'' \rightarrow Y$ dominating the resolutions f and f' , we compare the intersection cohomology motives coming from f and f'' , f' and f'' , and thus f and f' . As just noted, [Lemma 8.11](#) provides a canonical (pullback) map

$$\mathrm{Gr}_j^{\mathcal{P}^f} H_r^q(h(X)) \rightarrow \mathrm{Gr}_j^{\mathcal{P}^{f''}} H_r^q(h(X'')),$$

for all j (likewise for f'). We take $j = \dim Y$, and decompose the source and target according to [Theorem 8.13](#); our task is to show that the respective Y^{sm} -summands map isomorphically to one another. But this may be checked after taking (exact) ℓ -adic realizations, where it follows from the fact that f and f'' are isomorphisms over Y^{sm} (hence so is the map $X'' \rightarrow X$), and that IC_Y is the unique summand (in the decomposition theorem) of ${}^p H^0(f_* \mathbb{Q}_\ell[\dim Y])$ and ${}^p H^0(f''_* \mathbb{Q}_\ell[\dim Y])$ supported on Y^{sm} .

(2) In particular, [Corollary 8.15](#) completes the proof of [Theorem 6.1](#).

(3) Let us now take k to be a finite extension of \mathbb{Q}_p , with $\ell = p$. Let Y/k be a projective variety — this way we avoid discussing weight filtrations, and in particular do not have to be concerned that k is not finitely generated over \mathbb{Q} — so that $\mathrm{IH}^q(Y_{\bar{k}}, \mathbb{Q}_p)$ has underlying motive $\mathrm{Gr}_{\dim X, Y^{\mathrm{sm}}}^{\mathcal{P}^f}(H^q(X))$, where $f : X \rightarrow Y$ is any resolution of singularities. By [Remark 8.16\(1\)](#), we can then canonically define the intersection de Rham cohomology of Y/k to be the de Rham realization (a filtered k -vector space) of the motive $\mathrm{Gr}_{\dim X, Y^{\mathrm{sm}}}^{\mathcal{P}^f}(H^q(X))$, and by general properties of \mathcal{M}_k we obtain a p -adic de Rham comparison isomorphism, compatible with morphisms of motivated motives.

(4) Finally, taking k to be a totally real field, [[Patrikis and Taylor 2015](#), Corollary B] extends from smooth projective varieties over k with Hodge-regular cohomology in some degree to arbitrary projective varieties over k with Hodge-regular intersection cohomology in some degree. Here we use the theorems of Gabber that $\{\mathrm{IH}^q(Y_{\bar{k}}, \mathbb{Q}_\ell)\}_\ell$ forms a weakly compatible system of pure Γ_k -representations. Consequently, these compatible systems (in the regular case) are strongly compatible, and the corresponding L-functions admit meromorphic continuation to the whole complex plane, with the expected functional equation. Is it possible to construct examples of such singular varieties Y ? Note that Yun’s construction in type G_2 and D_{2n} (the latter regarded as SO_{4n-1} -valued) do give families of examples of potentially automorphic motives — this is a special case of the examples arising from Katz’s theory, as discussed in [[Patrikis and Taylor 2015](#), §2]. The lifts of Yun’s examples constructed in [Corollary 4.10](#) are no longer Hodge-Tate regular, so no further examples of potentially automorphic motives result from the constructions of the present paper.

Acknowledgements

This paper could not exist without the beautiful work of Zhiwei Yun [2014a]. I am, moreover, very grateful to Yun for generously sharing his understanding of that paper with me. I am grateful to the anonymous referee for a careful reading and helpful comments. I thank Bhargav Bhatt for answering a question about stratifications, and Mark de Cataldo for his feedback on a draft of this paper. I thank the Institut Mathématique de Jussieu for its hospitality during part of the preparation of this paper.

References

- [André 1996a] Y. André, “On the Shafarevich and Tate conjectures for hyper-Kähler varieties”, *Math. Ann.* **305**:2 (1996), 205–248. [MR](#) [Zbl](#)
- [André 1996b] Y. André, “Pour une théorie inconditionnelle des motifs”, *Inst. Hautes Études Sci. Publ. Math.* **83** (1996), 5–49. [MR](#) [Zbl](#)
- [Arkhipov and Bezrukavnikov 2009] S. Arkhipov and R. Bezrukavnikov, “Perverse sheaves on affine flags and Langlands dual group”, *Israel J. Math.* **170** (2009), 135–183. [MR](#) [Zbl](#)
- [Beilinson et al. 1982] A. A. Beilinson, J. Bernstein, and P. Deligne, “Faisceaux pervers”, pp. 5–171 in *Analysis and topology on singular spaces, I* (Luminy, 1981), Astérisque **100**, Soc. Math. France, Paris, 1982. [MR](#) [Zbl](#)
- [de Cataldo 2012] M. A. A. de Cataldo, “The perverse filtration and the Lefschetz hyperplane theorem, II”, *J. Algebraic Geom.* **21**:2 (2012), 305–345. [MR](#) [Zbl](#)
- [de Cataldo and Migliorini 2005] M. A. A. de Cataldo and L. Migliorini, “The Hodge theory of algebraic maps”, *Ann. Sci. École Norm. Sup. (4)* **38**:5 (2005), 693–750. [MR](#) [Zbl](#)
- [de Cataldo and Migliorini 2010] M. A. A. de Cataldo and L. Migliorini, “The perverse filtration and the Lefschetz hyperplane theorem”, *Ann. of Math. (2)* **171**:3 (2010), 2089–2113. [MR](#) [Zbl](#)
- [de Cataldo and Migliorini 2014] M. A. A. de Cataldo and L. Migliorini, “The projectors of the decomposition theorem are motivic”, preprint, 2014. [arXiv](#)
- [Deligne 1971a] P. Deligne, “Théorie de Hodge, I”, pp. 425–430 in *Actes du Congrès International des Mathématiciens, Tome I* (Nice, 1970), Gauthier-Villars, Paris, 1971. [MR](#) [Zbl](#)
- [Deligne 1971b] P. Deligne, “Théorie de Hodge, II”, *Inst. Hautes Études Sci. Publ. Math.* **40** (1971), 5–57. [MR](#) [Zbl](#)
- [Deligne 1974] P. Deligne, “Théorie de Hodge, III”, *Inst. Hautes Études Sci. Publ. Math.* **44** (1974), 5–77. [MR](#) [Zbl](#)
- [Deligne 1980] P. Deligne, “La conjecture de Weil, II”, *Inst. Hautes Études Sci. Publ. Math.* **52** (1980), 137–252. [MR](#) [Zbl](#)
- [Faltings 2003] G. Faltings, “Algebraic loop groups and moduli spaces of bundles”, *J. Eur. Math. Soc. (JEMS)* **5**:1 (2003), 41–68. [MR](#) [Zbl](#)
- [Frenkel and Gross 2009] E. Frenkel and B. Gross, “A rigid irregular connection on the projective line”, *Ann. of Math. (2)* **170**:3 (2009), 1469–1512. [MR](#) [Zbl](#)
- [Gaitsgory 2007] D. Gaitsgory, “On de Jong’s conjecture”, *Israel J. Math.* **157** (2007), 155–191. [MR](#) [Zbl](#)
- [Gillet and Soulé 1996] H. Gillet and C. Soulé, “Descent, motives and K -theory”, *J. Reine Angew. Math.* **478** (1996), 127–176. [MR](#) [Zbl](#)

- [Guillén and Navarro Aznar 1990] F. Guillén and V. Navarro Aznar, “Sur le théorème local des cycles invariants”, *Duke Math. J.* **61**:1 (1990), 133–155. [MR](#) [Zbl](#)
- [Guillén and Navarro Aznar 2002] F. Guillén and V. Navarro Aznar, “Un critère d’extension des foncteurs définis sur les schémas lisses”, *Publ. Math. Inst. Hautes Études Sci.* **95** (2002), 1–91. [MR](#) [Zbl](#)
- [Heinloth et al. 2013] J. Heinloth, B.-C. Ngô, and Z. Yun, “Kloosterman sheaves for reductive groups”, *Ann. of Math. (2)* **177**:1 (2013), 241–310. [MR](#) [Zbl](#)
- [Huber 1997] A. Huber, “Mixed perverse sheaves for schemes over number fields”, *Compositio Math.* **108**:1 (1997), 107–121. [MR](#) [Zbl](#)
- [Jouanolou 1973] J. P. Jouanolou, “Une suite exacte de Mayer–Vietoris en K -théorie algébrique”, pp. 293–316. *Lecture Notes in Math.*, Vol. 341 in *Algebraic K-theory, I: Higher K-theories* (Battelle Memorial Institute, Seattle, WA, 1972), edited by H. Bass, Springer, Berlin, 1973. [MR](#) [Zbl](#)
- [Jouanolou 1979] J.-P. Jouanolou, *Théorèmes de Bertini et applications*, Université Louis Pasteur, Département de Mathématique, Institut de Recherche Mathématique Avancée, Strasbourg, 1979. [MR](#) [Zbl](#)
- [Katz 1996] N. M. Katz, *Rigid local systems*, *Annals of Mathematics Studies* **139**, Princeton University Press, 1996. [MR](#) [Zbl](#)
- [Kollár 2005] J. Kollár, “Resolution of singularities – Seattle lecture”, preprint, 2005. [arXiv](#)
- [Laszlo and Olsson 2008] Y. Laszlo and M. Olsson, “The six operations for sheaves on Artin stacks, II: Adic coefficients”, *Publ. Math. Inst. Hautes Études Sci.* **107** (2008), 169–210. [MR](#) [Zbl](#)
- [Lazarsfeld 2004] R. Lazarsfeld, *Positivity in algebraic geometry, I*, *Ergebnisse der Mathematik und ihrer Grenzgebiete. 3. Folge. A Series of Modern Surveys in Mathematics* **48**, Springer, Berlin, 2004. [MR](#) [Zbl](#)
- [Mirković and Vilonen 2007] I. Mirković and K. Vilonen, “Geometric Langlands duality and representations of algebraic groups over commutative rings”, *Ann. of Math. (2)* **166**:1 (2007), 95–143. [MR](#) [Zbl](#)
- [Morel 2012] S. Morel, “Complexes mixtes sur un schéma de type fini sur \mathbb{Q} ”, preprint, 2012, available at https://web.math.princeton.edu/~smorel/sur_Q.pdf.
- [Pappas and Rapoport 2008] G. Pappas and M. Rapoport, “Twisted loop groups and their affine flag varieties”, *Adv. Math.* **219**:1 (2008), 118–198. [MR](#) [Zbl](#)
- [Patrikis 2014a] S. Patrikis, “Generalized Kuga–Satake theory and rigid local systems, I: the middle convolution”, preprint, 2014. [arXiv](#)
- [Patrikis 2014b] S. Patrikis, “Variations on a theorem of Tate”, preprint, 2014. To appear in *Memoirs of the AMS*. [arXiv](#)
- [Patrikis 2015] S. Patrikis, “On the sign of regular algebraic polarizable automorphic representations”, *Math. Ann.* **362**:1-2 (2015), 147–171. [MR](#) [Zbl](#)
- [Patrikis and Taylor 2015] S. Patrikis and R. Taylor, “Automorphy and irreducibility of some l -adic representations”, *Compos. Math.* **151**:2 (2015), 207–229. [MR](#) [Zbl](#)
- [Serre 1977] J.-P. Serre, “Modular forms of weight one and Galois representations”, pp. 193–268 in *Algebraic number fields: L-functions and Galois properties* (University of Durham, 1975), edited by A. Fröhlich, Academic Press, London, 1977. [MR](#) [Zbl](#)
- [Wintenberger 1995] J.-P. Wintenberger, “Relèvement selon une isogénie de systèmes l -adiques de représentations galoisiennes associés aux motifs”, *Invent. Math.* **120**:2 (1995), 215–240. [MR](#) [Zbl](#)
- [Yun 2011] Z. Yun, “Global Springer theory”, *Adv. Math.* **228**:1 (2011), 266–328. [MR](#) [Zbl](#)

[Yun 2013] Z. Yun, “Rigidity in the Langlands correspondence and applications”, preprint, 2013, available at <http://stanford.edu/~zwyun/Rigid-ICCM.pdf>. To appear in *Sixth International Congress of Chinese Mathematicians*.

[Yun 2014a] Z. Yun, “Motives with exceptional Galois groups and the inverse Galois problem”, *Invent. Math.* **196**:2 (2014), 267–337. [MR](#) [Zbl](#)

[Yun 2014b] Z. Yun, “Rigidity in automorphic representations and local systems”, pp. 73–168 in *Current developments in mathematics 2013* (Harvard University, Cambridge, MA), edited by D. Jerison et al., International Press, Somerville, MA, 2014. [MR](#) [Zbl](#)

Communicated by Hélène Esnault

Received 2015-06-06

Revised 2016-01-06

Accepted 2016-06-11

patrikis@math.utah.edu

*Department of Mathematics, University of Utah,
155 S 1400 E, Salt Lake City, UT 84112, United States*

Lifting preprojective algebras to orders and categorifying partial flag varieties

Laurent Demonet and Osamu Iyama

We describe a categorification of the cluster algebra structure of multihomogeneous coordinate rings of partial flag varieties of arbitrary Dynkin type using Cohen–Macaulay modules over orders. This completes the categorification of Geiss, Leclerc and Schröer by adding the missing coefficients. To achieve this, for an order A and an idempotent $e \in A$, we introduce a subcategory $\text{CM}_e A$ of CMA and study its properties. In particular, under some mild assumptions, we construct an equivalence of exact categories $(\text{CM}_e A)/[Ae] \cong \text{Sub} Q$ for an injective B -module Q , where $B := A/(e)$. These results generalize work by Jensen, King and Su concerning the cluster algebra structure of the Grassmannian $\text{Gr}_m(\mathbb{C}^n)$.

1. Introduction	1527
2. Main results	1531
3. Results on exact categories	1539
4. Equivalences arising from torsion pairs on exact categories	1549
5. Equivalences arising from orders and their idempotents	1557
6. Cluster algebra structure on coordinate rings of partial flag varieties	1570
Acknowledgement	1578
References	1578

1. Introduction

Geiss, Leclerc and Schröer [Geiss et al. 2008] introduced a cluster algebra structure on some subalgebra \tilde{A} of the multihomogeneous coordinate ring $\mathbb{C}[\mathcal{F}]$ of the partial flag variety $\mathcal{F} = \mathcal{F}(\Delta, J)$ corresponding to a Dynkin diagram Δ and a set J of vertices of Δ . They proved that $\tilde{A} = \mathbb{C}[\mathcal{F}]$ in type A , and conjectured that the

Demonet was partially supported by JSPS Grant-in-Aid for Young Scientist (B) 26800008. Iyama was partially supported by JSPS Grant-in-Aid for Scientific Research (B) 24340004, (B) 16H03923, (C) 23540045, and (S) 15H05738.

MSC2010: primary 16G30; secondary 13F60, 16G10, 16G50, 18E10, 18E30.

Keywords: orders, Cohen–Macaulay modules, finite-dimensional algebras, preprojective algebras, categorification, cluster algebras, partial flag varieties, exact categories.

equality holds after an appropriate localization for any Dynkin type (see Section 6 for more details). This structure generalizes previously known cases of Grassmannians, introduced for $\text{Gr}_2(\mathbb{C}^n)$ by Fomin and Zelevinsky [2003] (see also [Berenstein et al. 2005]) and generalized by Scott [2006] for $\text{Gr}_k(\mathbb{C}^n)$.

In the same paper, Geiss, Leclerc and Schröer introduced a partial categorification of this cluster algebra structure on $\tilde{\mathcal{A}}$. A crucial role is played by the preprojective algebra Π of type Δ and a certain full subcategory $\text{Sub } Q_J$ of $\text{mod } \Pi$ which is Frobenius and stably 2-Calabi–Yau. More precisely, they introduced a cluster character $\tilde{\varphi} : \text{Sub } Q_J \rightarrow \tilde{\mathcal{A}}$ which gives a bijection

$$\{\text{reachable indecomposable rigid objects in } \text{Sub } Q_J\} / \cong \xleftrightarrow{1-1} \{\text{cluster variables and coefficients of } \tilde{\mathcal{A}}\} \setminus \{\Delta_j \mid j \in J\},$$

where Δ_j is the principal generalized minor corresponding to $j \in J$.

One of the aim of this paper is to look for a stably 2-Calabi–Yau category extending $\text{Sub } Q_J$ whose reachable indecomposable rigid objects correspond to cluster variables and all coefficients of $\tilde{\mathcal{A}}$. Jensen, King and Su [Jensen et al. 2016] achieved this in the case of classical Grassmannians (i.e., $\Delta = A_n$ for $n \geq 0$ and $\#J = 1$) by using orders (see also [Baur et al. 2016] for an interpretation in terms of dimer models). In this article, we extend their method to any arbitrary Dynkin diagram Δ and arbitrary set of vertices J .

Throughout the introduction, for simplicity, let $R := k[[t]]$ be the formal power series ring over an arbitrary field k . For an R -order A (i.e., an R -algebra that is free of finite rank as an R -module), we denote by $\text{CM } A$ the category of Cohen–Macaulay modules over A (i.e., A -modules that are free of finite rank over R). For an idempotent $e \in A$, we define

$$\text{CM}_e A := \{X \in \text{CM } A \mid eX \in \text{proj}(eAe)\}.$$

We prove the following result:

Theorem A (Theorems 6.10 and 6.12). *Let Δ be a Dynkin diagram, and J be a set of vertices of Δ . Then, there exist a $\mathbb{C}[[t]]$ -order A , an idempotent $e \in A$ such that $\text{CM}_e A$ is Frobenius and stably 2-Calabi–Yau, and a cluster character $\psi : \text{CM}_e A \rightarrow \tilde{\mathcal{A}}$ such that*

- (a) *ψ induces a bijection between*
 - *isomorphism classes of reachable indecomposable rigid objects of $\text{CM}_e A$,*
 - *cluster variables and coefficients of $\tilde{\mathcal{A}}$,*
- (b) *ψ induces a bijection between*
 - *isomorphism classes of reachable basic cluster tilting objects of $\text{CM}_e A$,*
 - *clusters of $\tilde{\mathcal{A}}$.*

Moreover, it commutes with mutation of cluster tilting objects and mutation of clusters.

To prove [Theorem A](#), we generalize techniques introduced by Jensen, King and Su [[Jensen et al. 2016](#)] for Grassmannians in type A (see also [[Demonet and Luo 2016b](#)] for Grassmannians of 2-dimensional planes in type A). Meanwhile, we need to prove general results on orders.

The study of Cohen–Macaulay modules (also known as lattices) over orders is a classical subject in representation theory. We refer to [[Auslander 1978](#); [Curtis and Reiner 1981](#); [Leuschke and Wiegand 2012](#); [Simson 1992](#); [Yoshino 1990](#)] for a general background on this subject. We also refer to [[Amiot et al. 2015](#); [Araya 1999](#); [Demonet and Luo 2016a](#); [2016b](#); [Herschend et al. 2014](#); [de Thanhoffer de Völcsey and Van den Bergh 2010](#); [Iyama and Takahashi 2013](#); [Kajiura et al. 2007](#); [2009](#); [Keller and Reiten 2008](#)] for recent results about connections with tilting theory and cluster categories.

We consider an R -order A and an idempotent $e \in A$ such that $B := A/(e)$ is finite-dimensional over k . Let $K := k((t))$ be the fraction field of R , let $U := \text{Hom}_A(B, Ae \otimes_R (K/R))$ and let $\text{Sub } U$ be the category of B -submodules of objects U^n for $n \geq 0$. We consider the exact full subcategory

$$\text{mod}_e A := \{X \in \text{mod } A \mid eX \in \text{proj}(eAe)\}$$

of $\text{mod } A$. Under this setting, we prove the following generalization of a result of [[Jensen et al. 2016](#)].

Theorem B ([Theorem 2.2](#)). *Assume that Ae is injective in $\text{CM}_e A$ and has injective dimension at most 1 in $\text{mod}_e A$. Then U is injective in $\text{mod } B$ and there is an equivalence of exact categories*

$$B \otimes_A - : (\text{CM}_e A)/[Ae] \xrightarrow{\sim} \text{Sub } U.$$

In particular, if e and g are idempotents of an R -order A such that $B = A/(e)$ is finite-dimensional and $Ae \cong \text{Hom}_R(gA, R)$ as left A -modules, then the hypotheses of [Theorem B](#) are satisfied and U is the injective B -module corresponding to the idempotent g (see [Theorem 2.1](#)). Let us give a motivating example:

Example. For $n \geq 1$, we consider the pair (A, e) defined as

$$A := \begin{bmatrix} R & R \\ (t^n) & R \end{bmatrix} \quad \text{and} \quad e := \begin{bmatrix} 1 & 0 \\ 0 & 0 \end{bmatrix}.$$

We have $Ae \cong \text{Hom}_R((1 - e)A, R)$ and $B = A/(e) \cong k[t]/(t^n)$. So according to [Theorem B](#),

$$(\text{CM}_e A)/[Ae] \cong \text{Sub } U = \text{mod } B.$$

Notice that here $\text{CM}(eAe) = \text{proj}(eAe)$, so $\text{CM}_e A = \text{CM } A$. We can illustrate this fact by drawing the Auslander–Reiten quivers of $\text{CM } A$ and $\text{mod } B$:

$$\begin{array}{c}
 \text{CM}_e A : \left[\begin{array}{c} R \\ (t^n) \end{array} \right] \xrightleftharpoons[t]{\quad} \left[\begin{array}{c} R \\ (t^{n-1}) \end{array} \right] \xrightleftharpoons[t]{\quad} \left[\begin{array}{c} R \\ (t^{n-2}) \end{array} \right] \xrightleftharpoons[t]{\quad} \cdots \xrightleftharpoons[t]{\quad} \left[\begin{array}{c} R \\ (t) \end{array} \right] \xrightleftharpoons[t]{\quad} \left[\begin{array}{c} R \\ R \end{array} \right] \\
 B \otimes_A - \downarrow \\
 \text{mod } B : \quad k[t]/(t) \xrightleftharpoons[t]{\quad} k[t]/(t^2) \xrightleftharpoons[t]{\quad} \cdots \xrightleftharpoons[t]{\quad} k[t]/(t^{n-1}) \xrightleftharpoons[t]{\quad} k[t]/(t^n)
 \end{array}$$

where projective-injective objects are leftmost and rightmost in the first row and only rightmost in the second row. On the other objects, the Auslander–Reiten translation acts as the identity.

As an application of [Theorem B](#), we get the following, which is fundamental for [Theorem A](#):

Corollary C (Corollary of [Theorem 2.1](#)). *Let B be a finite-dimensional self-injective k -algebra. We define a Gorenstein order A over $R = k[[t]]$ and an idempotent e of A by*

$$A := B \otimes_k \begin{bmatrix} R & R \\ tR & R \end{bmatrix} \quad \text{and} \quad e := \begin{bmatrix} 1 & 0 \\ 0 & 0 \end{bmatrix}.$$

Then we have an equivalence of exact categories $(\text{CM}_e A)/[Ae] \cong \text{mod } B$, which induces a triangle equivalence $\underline{\text{CM}}_e A \cong \underline{\text{mod}} B$ between stable categories.

Additionally, we prove a categorical version of [Theorem B](#) in the context of exact categories:

Theorem D ([Theorem 4.7](#)). *Let \mathcal{E} be an exact category which is Hom-finite over a field k . We suppose that*

- $(\mathcal{A}, \mathcal{B})$ and $(\mathcal{B}, \mathcal{C})$ are torsion pairs in \mathcal{E} ;
- \mathcal{E} has enough projective objects, which belong to \mathcal{C} ;
- there exists a projective object P in \mathcal{E} which is injective in \mathcal{C} and satisfies $\mathcal{A} = \text{add } P$;
- \mathcal{B} is an abelian category whose exact structure is compatible with that of \mathcal{E} .

Then, there is an equivalence of exact categories

$$\mathcal{C}/[\mathcal{A}] \xrightarrow{\sim} \text{Sub } U,$$

where U is an (explicitly constructed) injective object of \mathcal{B} .

Notice that we need and we prove more general versions of [Theorems B](#) and [D](#), with more technical hypotheses and more precise conclusions.

The structure of this paper is as follows. In [Section 2](#), we explain main results about orders over an arbitrary complete discrete valuation ring R , and provide more general and more detailed versions of [Theorem B](#). We also give a systematic way to construct pairs (A, e) satisfying the hypotheses of [Theorem B](#) for a prescribed

algebra B . The results of Section 2 are proven in Section 5. In Section 3, we recall the basics of exact categories and we give sufficient conditions for an ideal quotient category $\mathcal{E}/[\mathcal{F}]$ of an exact category \mathcal{E} by a subcategory \mathcal{F} of projective-injective objects to inherit the exact structure of \mathcal{E} . In Section 4, we give extended versions of Theorem D. Finally, in Section 6, we prove Theorem A.

2. Main results

2A. Orders. Let R be a complete discrete valuation ring and K be its field of fractions. Let A be an R -order, i.e., an R -algebra which is free of finite rank as an R -module. We denote by $\text{f.l. } A$ the full subcategory of $\text{mod } A$ consisting of finite-length A -modules, or equivalently A -modules which are of finite length over R . Recall that, in this context, a finitely generated A -module X is (*maximal*) *Cohen–Macaulay* if the following equivalent conditions are satisfied:

- (i) X is free (of finite rank) as an R -module;
- (ii) $\text{Hom}_A(\text{f.l. } A, X) = 0$, or equivalently $\text{soc } X = 0$;
- (iii) $\text{Ext}_A^1(X, \text{Hom}_R(A, R)) = 0$, or equivalently, $\text{Ext}_A^i(X, \text{Hom}_R(A, R)) = 0$ for any $i > 0$.

We denote by $\text{CM } A$ the exact full subcategory of $\text{mod } A$ consisting of Cohen–Macaulay A -modules. Since A is an R -order, both A and $\text{Hom}_R(A, R)$ are in $\text{CM } A$. It is clear from (ii) that $(\text{f.l. } A, \text{CM } A)$ is a torsion pair in $\text{mod } A$, which can be seen as coming from the cotilting A -module $\text{Hom}_R(A, R)$.

For an idempotent e of A , we consider a full subcategory of $\text{CM } A$:

$$\text{CM}_e A := \{X \in \text{CM } A \mid eX \in \text{proj}(eAe)\}.$$

This is clearly closed under extensions, and hence forms an exact category naturally. If eAe is a hereditary order (i.e., $\text{gl.dim } eAe = 1$), then $\text{CM}_e A = \text{CM } A$ holds because $\text{CM}(eAe) = \text{proj}(eAe)$.

Our first main theorem, generalizing [Jensen et al. 2016], is the following one:

Theorem 2.1. *Let A be an R -order, and e be an idempotent of A . Assume that the following conditions are satisfied:*

- $B := A/(e)$ satisfies $\text{length}_R B < \infty$.
- There is an idempotent $g \in A$ such that $\text{add } Ae = \text{add } \text{Hom}_R(gA, R)$ as A -modules.

Then the following assertions hold:

- (a) We have an equivalence of exact categories

$$F = B \otimes_A - : (\text{CM}_e A)/[Ae] \xrightarrow{\sim} \text{Sub } Q_g,$$

where Q_g is the injective B -module associated with the image of the idempotent g in B .

(b) A quasi-inverse of F is $\text{Hom}_R(\Omega_A \text{Hom}_R(-, K/R), R)$, where Ω_A is the syzygy over A .

We assume in addition that the following hypotheses hold:

- There exists an idempotent $f \in A$ such that $\text{add } Af = \text{add } \text{Hom}_R(eA, R)$ as A -modules.
- eAe is a Gorenstein order.

Then the following conclusions hold:

(c) The module Q_g is a projective B -module satisfying $\text{add } Q_g = \text{add } Bf$.

(d) If $A \in \text{CM}_e A$, then $\text{Sub } Q_g = \text{Sub } B$.

We suppose in addition that A and $\text{Hom}_R(A, R)$ are in $\text{CM}_e A$.

(e) The order A is Gorenstein if and only if B is Iwanaga–Gorenstein of dimension at most 1, i.e., $\text{inj.dim } B \leq 1$ and $\text{inj.dim } B_B \leq 1$.

(f) If the conditions in (e) are satisfied, then we have triangle equivalences

$$\underline{\text{CM}}_e A \cong \underline{\text{Sub}} Q_g = \underline{\text{Sub}} B,$$

where $\underline{\text{CM}}_e A := (\text{CM}_e A)/[A]$ and $\underline{\text{Sub}} B = (\text{Sub } B)/[B]$.

Corollary C presented in the introduction is an immediate consequence of **Theorem 2.1** as it is immediate that $Ae \cong \text{Hom}_R(gA, R)$ for $g := 1 - e$ in that case. In this paper, a more general version of **Theorem 2.1** plays an important role. Again let A be an R -order and e an idempotent of A . Let

$$\text{mod}_e A := \{X \in \text{mod } A \mid eX \in \text{proj}(eAe)\}.$$

We consider the following conditions:

(E1) Ae is injective in $\text{CM}_e A$, or equivalently, $\text{Ext}_A^1(\text{CM}_e A, Ae) = 0$;

(E2) $\text{Ext}_{\text{mod}_e A}^2(\text{mod}_e A, Ae) = 0$;

(E2)⁺ $\text{Ext}_A^2(\text{mod}_e A, Ae) = 0$.

We recall the definition of the $\text{Ext}_{\mathcal{E}}^i$ in **Section 3** for exact categories \mathcal{E} . For a subcategory \mathcal{E} of $\text{mod } A$, notice that $\text{Ext}_{\mathcal{E}}^i$ is not necessarily the restriction of Ext_A^i , except for $i = 1$. In **Lemma 5.7**, we prove the following implications:

- We have (E2)⁺ \Rightarrow (E2).
- If $Ae = \text{Hom}_R(gA, R)$ for some idempotent $g \in A$, then (E1) and (E2)⁺ are satisfied.
- If (E1) is satisfied and $A \in \text{CM}_e A$, then (E2)⁺ is satisfied.

Theorem 2.1 follows from the next result:

Theorem 2.2. *Let A be an R -order and e an idempotent of A such that $B := A/(e)$ satisfies $\text{length}_R B < \infty$. Then:*

- (a) $(\text{add } Ae, \text{ mod } B)$ and $(\text{ mod } B, \text{CM}_e A)$ are torsion pairs in $\text{mod}_e A$.
- (b) Let $\mathcal{E}_1 := \{X \in \text{mod}_e A \mid \text{Ext}_A^1(X, Ae) = 0\}$. We have an equivalence

$$B \otimes_A - : \mathcal{E}_1/[Ae] \xrightarrow{\sim} \text{mod } B. \tag{2-1}$$

If (E1) is satisfied, then the following assertion holds:

- (c) Let $U := \text{Hom}_A(B, Ae \otimes_R (K/R)) \in \text{mod } B$, where K is the fraction field of R . The equivalence (2-1) restricts to an equivalence

$$B \otimes_A - : (\text{CM}_e A)/[Ae] \xrightarrow{\sim} \text{Sub } U. \tag{2-2}$$

If (E1) and (E2) are satisfied, then the following assertions hold:

- (d) U is an injective B -module.
- (e) (2-1) and (2-2) are equivalences of exact categories, where $\mathcal{E}_1/[Ae]$ and $(\text{CM}_e A)/[Ae]$ inherit canonically the exact structure of \mathcal{E}_1 and $\text{CM}_e A$ (see Section 3).
- (f) The exact categories \mathcal{E}_1 , $\text{CM}_e A$, $\text{mod}_e A$ and $\text{Sub } U$ have enough projective objects and enough injective objects.
- (g) Let P be a projective cover of $\text{soc } U$ as a B -module. Then, we have the equality $\mathcal{E}_1 = \{X \in \text{mod}_e A \mid \text{Hom}_A(P, X) = 0\}$.

2B. Change of orders. We give a systematic method to construct pairs of orders and their idempotents which satisfy the conditions (E1) and (E2).

Let A be an R -order, e an idempotent of A and B a factor algebra of $A/(e)$. We suppose that the following two conditions are satisfied:

- (C1) $\text{length}_R B < \infty$;
- (C2) $B \in \text{Sub}(Ae \otimes_R (K/R))$.

Let $\text{mod}_e^B A$ be the category of all $X \in \text{mod } A$ such that there exists an exact sequence

$$0 \rightarrow P \rightarrow X \rightarrow Y \rightarrow 0$$

with $P \in \text{add } Ae$ and $Y \in \text{mod } B$. Let $\text{CM}_e^B A := \text{CM } A \cap \text{mod}_e^B A$ and consider the condition:

- (C3) $\text{Ext}_A^1(\text{CM}_e^B A, Ae) = 0$.

We will construct a new order A' under this setting. Thanks to (C2), there is a monomorphism $\iota : B \hookrightarrow (Ae \otimes_R (K/R))^{\oplus \ell}$. Applying $Ae^{\oplus \ell} \otimes_R -$ to the exact sequence $0 \rightarrow R \rightarrow K \rightarrow K/R \rightarrow 0$ and taking a pullback via ι , we get a short exact sequence

$$0 \rightarrow P \rightarrow \tilde{B} \rightarrow B \rightarrow 0$$

with $P \in \text{add } Ae$ and $\tilde{B} \in \text{CM } A$. We clearly have $\tilde{B} \in \text{CM}_e^B A$. Using (C3), one can check \tilde{B} is independent of the choice of ι up to a direct summand in $\text{add } Ae$ (see Theorem 4.1(a)). Let

$$W := Ae \oplus \tilde{B} \quad \text{and} \quad A' := \text{End}_A(W).$$

We can regard naturally e as an idempotent of A' . Notice that A' is uniquely defined up to Morita equivalence.

Theorem 2.3. *We assume that (C1), (C2) and (C3) hold. Then the following assertions hold:*

- (a) *We have a canonical isomorphism $B \cong A'/(e)$ of R -algebras.*
- (b) *We have (E1) holds, that is, $\text{Ext}_{A'}^1(\text{CM}_e A', A'e) = 0$, and (E2)⁺ holds, that is, $\text{Ext}_{A'}^2(\text{mod}_e A', A'e) = 0$.*
- (c) *Let $U := \text{Hom}_{A'}(B, A'e \otimes_R (K/R)) \in \text{mod } B$. Then U is an injective B -module and we have an equivalence of exact categories*

$$B \otimes_{A'} - : (\text{CM}_e A')/[A'e] \xrightarrow{\sim} \text{Sub } U.$$

- (d) *The class of short exact sequences of $\text{mod } A$ with three terms in $\text{mod}_e^B A$ gives the structure of an exact category on $\text{mod}_e^B A$. The same holds for $\text{CM}_e^B A$. For these structures, the functors*

$$\text{Hom}_A(W, -) : \text{mod } A \rightarrow \text{mod } A' \quad \text{and} \quad W \otimes_{A'} - : \text{mod } A' \rightarrow \text{mod } A$$

induce quasi-inverse equivalences of exact categories between $\text{mod}_e^B A$ and $\text{mod}_e A'$ on the one hand, and between $\text{CM}_e^B A$ and $\text{CM}_e A'$ on the other hand.

- (e) *We have a commutative diagram*

$$\begin{array}{ccc} \text{CM}_e A' & \xrightarrow{B \otimes_{A'} -} & \text{Sub } U \\ W \otimes_{A'} - \downarrow \wr & & \downarrow \\ \text{CM}_e^B A & \xrightarrow{B \otimes_A -} & \text{mod } B \end{array}$$

where all functors induce isomorphisms of Ext^1 and the left side is an equivalence of exact categories for the exact structure on $\text{CM}_e^B A$ given in (d).

Let us finally introduce a simple criterion for (C1), (C2) and (C3) to be satisfied:

Lemma 2.4. *Let A be an R -order, e an idempotent of A and B a factor algebra of $A/(e)$. Let us assume that there exists an idempotent $g \in A$ such that $Ae \cong \text{Hom}_R(gA, R)$. Then (C3) holds. Moreover, if (C1) holds, then (C2) holds if and only if $(1 - g) \text{soc } B = 0$.*

We will prove Lemma 2.4 at the end of Section 5C.

In the rest of this subsection we give an example illustrating Theorem 2.3. Let $B = \Pi$ be the preprojective algebra of type A_3 over a field k . In other terms

$$\Pi = k \left(\begin{array}{ccccc} & & \xrightarrow{\alpha_1} & & \\ & & 2 & \xrightarrow{\alpha_2} & 3 \\ & \xleftarrow{\beta_1} & & \xleftarrow{\beta_2} & \end{array} \right) / (\alpha_1\beta_1, \alpha_2\beta_2 - \beta_1\alpha_1, \beta_2\alpha_2).$$

This algebra can also be realized as the following subquotient of the matrix algebra $M_3(k[\varepsilon])$:

$$\Pi = \begin{bmatrix} k[\varepsilon]/(\varepsilon) & k[\varepsilon]/(\varepsilon) & k[\varepsilon]/(\varepsilon) \\ (\varepsilon)/(\varepsilon^2) & k[\varepsilon]/(\varepsilon^2) & k[\varepsilon]/(\varepsilon) \\ (\varepsilon^2)/(\varepsilon^3) & (\varepsilon)/(\varepsilon^2) & k[\varepsilon]/(\varepsilon) \end{bmatrix}.$$

Let us define $R := k[[t]]$ and $S := R[\varepsilon]$. The R -order considered in Corollary C is

$$A := \begin{bmatrix} S/(\varepsilon) & S/(\varepsilon) & S/(\varepsilon) & S/(\varepsilon) & S/(\varepsilon) & S/(\varepsilon) \\ (\varepsilon)/(\varepsilon^2) & S/(\varepsilon^2) & S/(\varepsilon) & (\varepsilon)/(\varepsilon^2) & S/(\varepsilon^2) & S/(\varepsilon) \\ (\varepsilon^2)/(\varepsilon^3) & (\varepsilon)/(\varepsilon^2) & S/(\varepsilon) & (\varepsilon^2)/(\varepsilon^3) & (\varepsilon)/(\varepsilon^2) & S/(\varepsilon) \\ (t)/(\varepsilon) & (t)/(\varepsilon) & (t)/(\varepsilon) & S/(\varepsilon) & S/(\varepsilon) & S/(\varepsilon) \\ (t\varepsilon)/(\varepsilon^2) & (t)/(\varepsilon^2) & (t)/(\varepsilon) & (\varepsilon)/(\varepsilon^2) & S/(\varepsilon^2) & S/(\varepsilon) \\ (t\varepsilon^2)/(\varepsilon^3) & (t\varepsilon)/(\varepsilon^2) & (t)/(\varepsilon) & (\varepsilon^2)/(\varepsilon^3) & (\varepsilon)/(\varepsilon^2) & S/(\varepsilon) \end{bmatrix}.$$

In Figure 1, we draw the Auslander–Reiten quiver of $\text{CM}_e A$, with notations

$$\begin{aligned} ij &:= (t^i \varepsilon^j) / (t^i \varepsilon^{j+1}), \\ \overline{ij} &:= (t^i \varepsilon^j) / (t^i \varepsilon^{j+2}), \\ ij - ij &:= \{(p, q) \in ij \times ij \mid p - q \in t \cdot ij\}. \end{aligned}$$

Thus, the identity of S induces a map $ij \rightarrow i'j'$ if and only if $(j, i) \geq (j', i')$ for the lexicographic order and analogous rules can be computed for \overline{ij} . All arrows are induced by multiplications by an element of S , which is ± 1 when it is not specified.

Let e_3, e_2, e_1, g_1, g_2 and g_3 be the idempotents corresponding, in this order, to the rows of the matrix. They satisfy

$$Ae_i \cong \text{Hom}_R(g_i A, R) \quad \text{and} \quad Ag_i \cong \text{Hom}_R(e_i A, R)$$

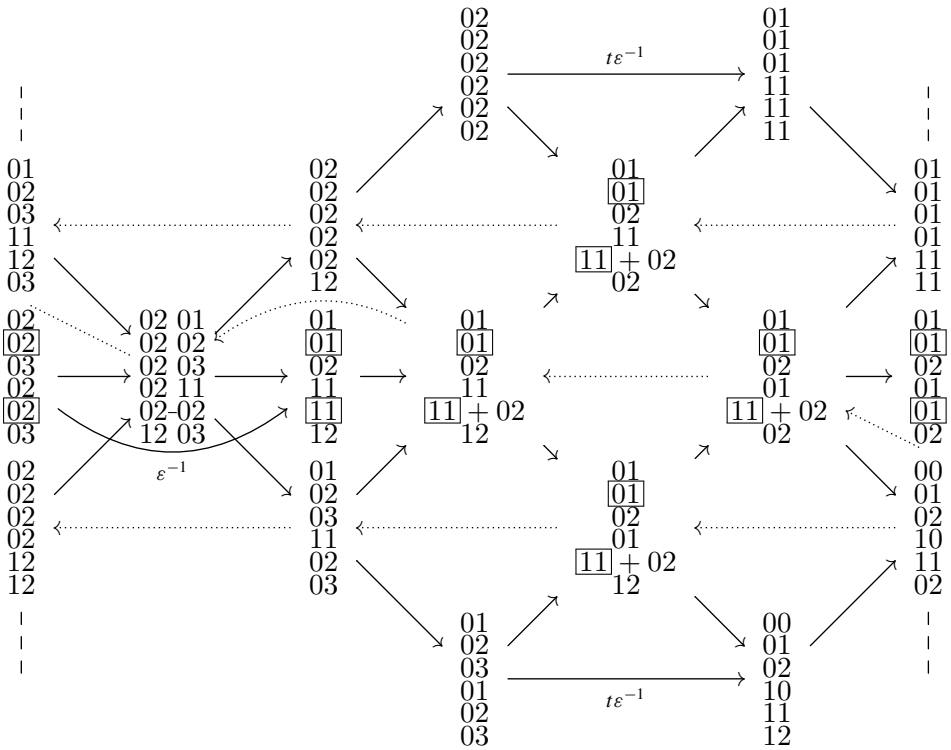

Figure 1. Auslander–Reiten quiver of $CM_e A$.

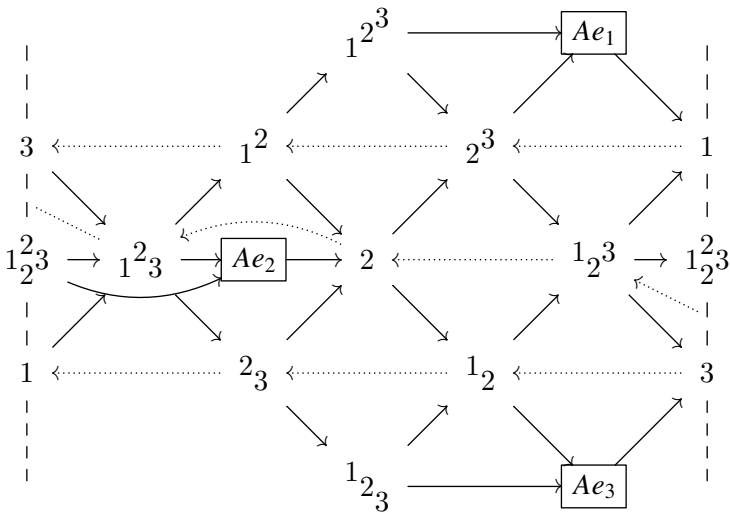

Figure 2. Auslander–Reiten quiver of $CM_e A$. Objects are represented by their image by F except objects of add Ae .

as A -modules. We fix the idempotent $e = e_1 + e_2 + e_3$. According to [Corollary C](#), we have an equivalence of exact categories

$$(\text{CM}_e A)/[Ae] \cong \text{mod } \Pi.$$

In [Figure 2](#), we draw the Auslander–Reiten quiver of $\text{CM}_e A$, replacing objects which are not in $\text{add } Ae$ by their image by F in $\text{Sub } U = \text{mod } \Pi$ (here $U = \Pi$). We obtain the Auslander–Reiten quiver of $\text{mod } \Pi$ by removing framed objects. The general relation between Auslander–Reiten quivers of $\text{CM}_e A$ and $\text{Sub } U$ will be discussed in [\[Demonet and Iyama ≥ 2016\]](#).

We explain the way to compute the minimal preimage of an object of $\text{Sub } U$ by F in this example. First, we know that preimages of simple modules S_i are coradicals of indecomposable direct summands of Ae . Thus, we find

$$F(S_1^\circ) \cong S_1, \quad F(S_2^\circ) \cong S_2, \quad F(S_3^\circ) \cong S_3,$$

where

$$S_1^\circ = \begin{bmatrix} S/(\varepsilon) \\ S/(\varepsilon) \\ S/(\varepsilon) \\ S/(\varepsilon) \\ (t)/(t\varepsilon) \\ (t)/(t\varepsilon) \end{bmatrix}, \quad S_2^\circ = \begin{bmatrix} S/(\varepsilon) \\ S/(\varepsilon^2) \\ (\varepsilon)/(\varepsilon^2) \\ (t)/(t\varepsilon) \\ (t, \varepsilon)/(\varepsilon^2) \\ (t\varepsilon)/(t\varepsilon^2) \end{bmatrix}, \quad S_3^\circ = \begin{bmatrix} S/(\varepsilon) \\ (\varepsilon)/(\varepsilon^2) \\ (\varepsilon^2)/(\varepsilon^3) \\ (t)/(t\varepsilon) \\ (t\varepsilon)/(t\varepsilon^2) \\ (\varepsilon^2)/(\varepsilon^3) \end{bmatrix}.$$

Let us calculate the preimage X° of 1^2_3 by F . There exists a pullback diagram

$$\begin{array}{ccccccc} 0 & \longrightarrow & Ae_1 \oplus Ae_3 & \longrightarrow & S_1^\circ \oplus S_3^\circ & \longrightarrow & S_1 \oplus S_3 \longrightarrow 0 \\ & & \parallel & & \downarrow & & \downarrow \\ 0 & \longrightarrow & Ae_1 \oplus Ae_3 & \longrightarrow & X^\circ & \longrightarrow & 1^2_3 \longrightarrow 0 \\ & & & & \downarrow & & \downarrow \\ & & & & S_2 & \xlongequal{\quad} & S_2 \end{array}$$

which permits us to get

$$X^\circ = \begin{bmatrix} S/(\varepsilon) & S/(\varepsilon) \\ S/(\varepsilon) & (\varepsilon)/(\varepsilon^2) \\ S/(\varepsilon) & (\varepsilon^2)/(\varepsilon^3) \\ S/(\varepsilon) & (t)/(t\varepsilon) \\ S/(\varepsilon) & (\varepsilon)/(\varepsilon^2) \\ (t)/(t\varepsilon) & (\varepsilon^2)/(\varepsilon^3) \end{bmatrix},$$

where

$$[S/(\varepsilon) - S/(\varepsilon)] := \{(x, y) \in S/(\varepsilon) \times S/(\varepsilon) \mid x - y \in t \cdot S/(\varepsilon)\}.$$

Thanks to [Theorem 2.3](#), we have $(\text{CM}_{e'} A')/[Ae']$ is equivalent to the subcategory of $\text{mod } \Pi$ consisting of modules whose socle is supported at vertices 1 and 3. To illustrate this fact, we give two representations of the Auslander–Reiten quiver of $\text{CM}_{e'} A'$ in [Figure 3](#).

2C. Notations. In this paper, if $f : X \rightarrow Y$ and $g : Y \rightarrow Z$ are two morphisms in a category, we write $fg : X \rightarrow Z$ for the composed morphism.

Let $\mathcal{A}b$ be the category of abelian groups. For an additive category \mathcal{A} , an \mathcal{A} -module is a contravariant additive functor $F : \mathcal{A} \rightarrow \mathcal{A}b$. We say that an \mathcal{A} -module F is *finitely generated* if there exists an epimorphism of \mathcal{A} -modules $\text{Hom}_{\mathcal{A}}(\mathcal{A}, X) \rightarrow F$ for some $X \in \mathcal{A}$.

3. Results on exact categories

The aim of this section is to study ideal quotient categories $\mathcal{E}/[\mathcal{F}]$ of an exact category \mathcal{E} by a full subcategory \mathcal{F} consisting of projective-injective objects. More precisely, we study conditions for $\mathcal{E}/[\mathcal{F}]$ to inherit the exact structure of \mathcal{E} . In particular, we prove that it is the case if and only if admissible monomorphisms and epimorphisms are mapped to categorical monomorphisms and epimorphisms by the canonical projection $\mathcal{E} \rightarrow \mathcal{E}/[\mathcal{F}]$. This is a particular case of [Theorem 3.6](#).

3A. Preliminaries about exact categories. We recall here main definitions and elementary results about exact categories. We consider an additive category \mathcal{E} endowed with a family \mathcal{S} of pairs of morphisms (f, g) of \mathcal{E} , where f is a kernel of g and g is a cokernel of f . We denote such a pair by

$$0 \rightarrow X \xrightarrow{f} Y \xrightarrow{g} Z \rightarrow 0,$$

and for $(f, g) \in \mathcal{S}$, we call (f, g) an *admissible short exact sequence*, f an *admissible monomorphism* and g an *admissible epimorphism*. We call $(\mathcal{E}, \mathcal{S})$ an *exact category* if it satisfies the following axioms due to Quillen [[1973](#)] and modified by Keller [[1990](#), Appendix A]:

(Ex0) \mathcal{S} is stable under isomorphisms and contains *split short exact sequences* of the form

$$0 \rightarrow X \xrightarrow{[\text{id}_X \ 0]} X \oplus Z \xrightarrow{\begin{bmatrix} 0 \\ \text{id}_Z \end{bmatrix}} Z \rightarrow 0.$$

(Ex1) The composition of two admissible epimorphisms is an admissible epimorphism.

(Ex1)^{op} The composition of two admissible monomorphisms is an admissible monomorphism.

(Ex2) For any admissible short exact sequence

$$0 \rightarrow X \xrightarrow{f} Y \xrightarrow{g} Z \rightarrow 0$$

and morphism $v : Z' \rightarrow Z$, we can form a *pullback diagram*, i.e., a commutative diagram of the form

$$\begin{array}{ccccccccc} 0 & \longrightarrow & X & \xrightarrow{f'} & Y' & \xrightarrow{g'} & Z' & \longrightarrow & 0 \\ & & \parallel & & \downarrow v' & & \downarrow v & & \\ 0 & \longrightarrow & X & \xrightarrow{f} & Y & \xrightarrow{g} & Z & \longrightarrow & 0 \end{array}$$

where the first row is an admissible short exact sequence.

(Ex2)^{op} For any admissible short exact sequence

$$0 \rightarrow X \xrightarrow{f} Y \xrightarrow{g} Z \rightarrow 0$$

and morphism $u : X \rightarrow X'$, we can form a *pushout diagram*, i.e., a commutative diagram of the form

$$\begin{array}{ccccccccc} 0 & \longrightarrow & X & \xrightarrow{f} & Y & \xrightarrow{g} & Z' & \longrightarrow & 0 \\ & & u \downarrow & & u' \downarrow & & \parallel & & \\ 0 & \longrightarrow & X' & \xrightarrow{f'} & Y' & \xrightarrow{g'} & Z & \longrightarrow & 0 \end{array}$$

where the second row is an admissible short exact sequence.

We often write \mathcal{E} instead of $(\mathcal{E}, \mathcal{S})$ when we consider only one exact structure on \mathcal{E} . When not specified, we use the terms *short exact sequence*, *monomorphism* and *epimorphism* for *admissible short exact sequence*, *admissible monomorphism*, *admissible epimorphism*, respectively. In contrast, we use *categorical monomorphism* or *categorical epimorphism* for a monomorphism or epimorphism which is not necessarily admissible.

We will use freely the following easy facts about exact categories:

- In (Ex2), we have the admissible short exact sequence

$$0 \rightarrow Y' \xrightarrow{[v' \ g']} Y \oplus Z' \xrightarrow{\begin{bmatrix} g \\ -v \end{bmatrix}} Z \rightarrow 0.$$

- In (Ex2), if v is an admissible epimorphism, then so is v' and $\text{Ker } v = (\text{Ker } v')g'$.
- In (Ex2), if v is an admissible monomorphism, then so is v' and $\text{Coker } v' = g(\text{Coker } v)$.

- In $(\text{Ex2})^{\text{op}}$, we have the admissible short exact sequence

$$0 \rightarrow X \xrightarrow{[u \ f]} X' \oplus Y \xrightarrow{\begin{bmatrix} f' \\ -u' \end{bmatrix}} Y' \rightarrow 0.$$

- In $(\text{Ex2})^{\text{op}}$, if u is an admissible epimorphism, then so is u' and $\text{Ker } u' = (\text{Ker } u) f$.
- In $(\text{Ex2})^{\text{op}}$, if u is an admissible monomorphism, then so is u' and $\text{Coker } u = f'(\text{Coker } u')$.
- If a morphism is an admissible monomorphism and an admissible epimorphism, then it is an isomorphism.
- If, in a morphism of short exact sequences, the left and right components are both admissible monomorphisms or epimorphisms, then the middle one is as well.
- In (Ex2) and $(\text{Ex2})^{\text{op}}$, the diagrams are uniquely determined up to unique isomorphisms.

Let us recall the following definition:

Definition 3.1. A functor F between exact categories $(\mathcal{E}, \mathcal{S})$ and $(\mathcal{E}', \mathcal{S}')$ is *exact* if $F(\mathcal{S}) \subset \mathcal{S}'$. An object $X \in \mathcal{E}$ is *projective* if $\text{Hom}_{\mathcal{E}}(X, -)$ is exact, and *injective* if $\text{Hom}_{\mathcal{E}}(-, X)$ is exact. We say that \mathcal{E} has *enough injective objects* if for any $X \in \mathcal{E}$ there exists a short exact sequence $0 \rightarrow X \rightarrow I \rightarrow Y \rightarrow 0$ in \mathcal{S} such that I is injective. We say that \mathcal{E} has *enough projective objects* if for any $X \in \mathcal{E}$ there exists a short exact sequence $0 \rightarrow Y \rightarrow P \rightarrow X \rightarrow 0$ in \mathcal{S} such that P is projective.

Recall that these notions permit the definition of extension functors $\text{Ext}_{\mathcal{E}}^i$ which satisfy the expected properties, either from Yoneda’s structure of long exact sequences, or using projective resolutions if \mathcal{E} has enough projective objects, or using injective resolutions if \mathcal{E} has enough injective objects, or more generally using the derived category of \mathcal{E} .

Throughout this paper, we will use the following definition:

Definition 3.2. Let \mathcal{E} and \mathcal{E}' be exact categories and $F : \mathcal{E} \rightarrow \mathcal{E}'$ an exact functor. We say that F is *exact bijective* if the induced morphism $\text{Ext}_{\mathcal{E}}^1(-, -) \rightarrow \text{Ext}_{\mathcal{E}'}^1(F-, F-)$ is an isomorphism. We say that F is an *equivalence of exact categories* if it is an exact bijective equivalence of categories (or, equivalently, an exact equivalence of categories with an exact quasi-inverse).

A typical example of exact bijective functor arises when \mathcal{E} is a full exact subcategory of \mathcal{E}' (i.e., a full subcategory which is closed under extensions).

Remark 3.3. Assume $F : \mathcal{E} \rightarrow \mathcal{E}'$ is a dense and exact bijective functor. Then:

- (a) For any $X \in \mathcal{E}$, we have X is projective if and only if FX is projective, and the dual statement holds for injectivity.

- (b) \mathcal{E} has enough projective objects if and only if \mathcal{E}' has enough projective objects, and the dual statement holds for injectivity.
- (c) \mathcal{E} is Frobenius if and only if \mathcal{E}' is Frobenius.

We give an elementary result about second extension groups:

Proposition 3.4. *Let $F : \mathcal{E} \rightarrow \mathcal{E}'$ be an exact bijective functor. Then, it induces a canonical natural monomorphism $\text{Ext}_{\mathcal{E}}^2(-, -) \hookrightarrow \text{Ext}_{\mathcal{E}'}^2(F-, F-)$.*

Proof. The existence of a map $\varphi : \text{Ext}_{\mathcal{E}}^2(-, -) \rightarrow \text{Ext}_{\mathcal{E}'}^2(F-, F-)$ is immediate. We consider an admissible 4-term exact sequence $\xi : 0 \rightarrow X \rightarrow Y_1 \rightarrow Y_2 \rightarrow Z \rightarrow 0$ which, by definition, comes from two short exact sequences

$$\xi_1 : 0 \rightarrow X \rightarrow Y_1 \rightarrow Y \rightarrow 0 \quad \text{and} \quad \xi_2 : 0 \rightarrow Y \rightarrow Y_2 \xrightarrow{u} Z \rightarrow 0.$$

Suppose that $\xi \in \text{Ker } \varphi_{Z,X}$. Applying $\text{Hom}_{\mathcal{E}}(-, X)$ and $\text{Hom}_{\mathcal{E}'}(F-, FX)$ to ξ_2 gives a commutative diagram of exact sequences:

$$\begin{array}{ccccccc} \text{Ext}_{\mathcal{E}}^1(Y_2, X) & \longrightarrow & \text{Ext}_{\mathcal{E}}^1(Y, X) & \longrightarrow & \text{Ext}_{\mathcal{E}}^2(Z, X) & \xrightarrow{\text{Ext}_{\mathcal{E}}^2(u, X)} & \text{Ext}_{\mathcal{E}}^2(Y_2, X) \\ \parallel & & \parallel & & \downarrow \varphi_{Z,X} & & \downarrow \\ \text{Ext}_{\mathcal{E}'}^1(FY_2, FX) & \longrightarrow & \text{Ext}_{\mathcal{E}'}^1(FY, FX) & \longrightarrow & \text{Ext}_{\mathcal{E}'}^2(FZ, FX) & \longrightarrow & \text{Ext}_{\mathcal{E}'}^2(FY_2, FX) \end{array}$$

By the definition of Yoneda product, $\xi \in \text{Ker } \text{Ext}_{\mathcal{E}}^2(u, X)$, so an easy diagram chase gives $\xi = 0$. □

Let us define important concepts:

Definition 3.5. Let \mathcal{E} be a Krull–Schmidt additive category and $\mathcal{E}' \subset \mathcal{E}$ an additive subcategory. Then:

- (a) We say that $f : X \rightarrow Y$ in \mathcal{E} is *left minimal* if for any $g \in \text{End}_{\mathcal{E}}(Y)$ such that $fg = f$, the map g is invertible, or equivalently, if for any idempotent $e \in \text{End}_{\mathcal{E}}(Y)$, we have $fe = f$ implies $e = \text{id}_Y$.
- (b) We say that $g : Y \rightarrow X$ in \mathcal{E} is *right minimal* if for any $f \in \text{End}_{\mathcal{E}}(Y)$ such that $fg = g$, the map f is invertible, or equivalently, if for any idempotent $e \in \text{End}_{\mathcal{E}}(Y)$, we have $eg = g$ implies $e = \text{id}_Y$.
- (c) We say that $f : X \rightarrow X'$ in \mathcal{E} is a *left \mathcal{E}' -approximation* (of X) if $X' \in \mathcal{E}'$ and any morphism from X to any object of \mathcal{E}' factors through f .
- (d) We say that $g : X' \rightarrow X$ in \mathcal{E} is a *right \mathcal{E}' -approximation* (of X) if $X' \in \mathcal{E}'$ and any morphism from any object of \mathcal{E}' to X factors through g .

Notice that, in the situation of the previous definition, if an object $X \in \mathcal{E}$ admits a left \mathcal{E}' -approximation, then it admits a left minimal \mathcal{E}' -approximation which is unique up to isomorphism, and an analogous statement holds for right \mathcal{E}' -approximations.

3B. Exact ideal quotients of an exact category. Let $(\mathcal{E}, \mathcal{S})$ be an exact category and \mathcal{E}' a full subcategory of \mathcal{E} which is closed under extensions. Then $(\mathcal{E}', \mathcal{S}')$ forms an exact category for the family \mathcal{S}' of all admissible exact sequences in \mathcal{S} whose terms belong to \mathcal{E}' .

We denote by \mathcal{F} a subcategory of \mathcal{E} satisfying $\text{Ext}_{\mathcal{E}}^1(\mathcal{F}, \mathcal{E}') = \text{Ext}_{\mathcal{E}}^1(\mathcal{E}', \mathcal{F}) = 0$. Let $\mathcal{S}'_{\mathcal{F}}$ be the class of pairs of morphisms in $\mathcal{E}'/[\mathcal{F}]$ which are isomorphic to a pair in $\pi(\mathcal{S}')$, where $\pi : \mathcal{E}' \rightarrow \mathcal{E}'/[\mathcal{F}]$ is the canonical functor.

Theorem 3.6. *The following are equivalent:*

- (i) $(\mathcal{E}'/[\mathcal{F}], \mathcal{S}'_{\mathcal{F}})$ is exact.
- (ii) For any admissible monomorphism f of $(\mathcal{E}', \mathcal{S}')$, the map $\pi(f)$ is a categorical monomorphism in $\mathcal{E}'/[\mathcal{F}]$, and the dual statement holds for epimorphisms.

In this case, $\pi : \mathcal{E}' \rightarrow \mathcal{E}'/[\mathcal{F}]$ is automatically exact bijective.

Proof. (i) \Rightarrow (ii) is trivial. Let us prove the converse. Let us first check that any $(\bar{f}, \bar{g}) \in \mathcal{S}'_{\mathcal{F}}$ is a kernel-cokernel pair. By (ii), \bar{f} is a monomorphism and \bar{g} is an epimorphism. By definition, we can lift (\bar{f}, \bar{g}) to $(f, g) \in \mathcal{S}'$. Suppose that $\bar{f}\bar{h} = 0$ for some morphism \bar{h} of $\mathcal{E}'/[\mathcal{F}]$. By definition, it means that there is a commutative diagram in \mathcal{E} of the form

$$\begin{array}{ccccccc}
 0 & \longrightarrow & X & \xrightarrow{f} & Y & \xrightarrow{g} & Z \longrightarrow 0 \\
 & & h' \downarrow & & \downarrow h & & \\
 & & F & \xrightarrow{f'} & Z' & &
 \end{array}$$

with $F \in \mathcal{F}$. As $\text{Ext}_{\mathcal{E}}^1(Z, F) = 0$, there exists $u : Y \rightarrow F$ such that $h' = fu$. Thus, $h = uf' + gv$ for some $v : Z \rightarrow Z'$ and $\bar{h} = \bar{g}\bar{v}$ holds. This proves that \bar{g} is a cokernel of \bar{f} . Dually, we prove that \bar{f} is a kernel of \bar{g} .

Let us check axioms of exact categories one by one:

(Ex0): This is obvious.

(Ex1): Suppose that $\bar{g} : X \rightarrow X'$ and $\bar{g}' : X' \rightarrow X''$ are epimorphisms in $\mathcal{S}'_{\mathcal{F}}$. It is easy to check that we can lift them to admissible epimorphisms $g : X \oplus F_1 \rightarrow X' \oplus F_2$ and $g' : X' \oplus F_3 \rightarrow X'' \oplus F_4$ of \mathcal{E}' . Thus $\bar{g}\bar{g}'$ can be lifted to an admissible epimorphism $X \oplus F_1 \oplus F_3 \rightarrow X'' \oplus F_2 \oplus F_4$ in \mathcal{E}' using **(Ex1)** in $(\mathcal{E}', \mathcal{S}')$. By definition, $\bar{g}\bar{g}'$ is then an epimorphism in $\mathcal{S}'_{\mathcal{F}}$.

(Ex1)^{op}: This is the dual of the previous item.

(Ex2): Let $\bar{g} : Y \rightarrow Z$ be an epimorphism in $\mathcal{S}'_{\mathcal{F}}$ and $\bar{v} : Z' \rightarrow Z$ be a morphism in $\mathcal{E}'/[\mathcal{F}]$. Without loss of generality, we can suppose that they come from lifts $g : Y \rightarrow Z$ and $v : Z' \rightarrow Z$ in \mathcal{E}' , where g is an admissible epimorphism. Thus, we

can complete the pair to a pullback diagram

$$\begin{array}{ccc} Y' & \xrightarrow{g'} & Z' \\ v' \downarrow & & \downarrow v \\ Y & \xrightarrow{g} & Z \end{array}$$

in \mathcal{E}' , where g' is an admissible epimorphism. Then $0 \rightarrow Y' \rightarrow Z' \oplus Y \rightarrow Z \rightarrow 0$ is in \mathcal{S}' , and its projection to $\mathcal{E}'/[\mathcal{F}]$ is in $\mathcal{S}'_{\mathcal{F}}$. Thus the diagram is also a pullback diagram in $\mathcal{E}'/[\mathcal{F}]$, and \bar{g}' is an epimorphism in $\mathcal{S}'_{\mathcal{F}}$.

(Ex2)^{op}: This is the dual of the previous item.

We have finished proving the equivalence. Let us check that the projection $\pi : \mathcal{E}' \rightarrow \mathcal{E}'/[\mathcal{F}]$ is exact bijective. First of all, for $X, Z \in \mathcal{E}'$, the induced map $\text{Ext}_{\mathcal{E}'}^1(Z, X) \rightarrow \text{Ext}_{\mathcal{E}'/[\mathcal{F}]}^1(\pi Z, \pi X)$ is clearly surjective. To prove that it is injective, let us consider a short exact sequence

$$0 \rightarrow X \xrightarrow{f} Y \xrightarrow{g} Z \rightarrow 0, \tag{3-1}$$

which splits in $\mathcal{E}'/[\mathcal{F}]$. By definition, it means that there is $g' : Z \rightarrow Y$ and two morphisms $u : Z \rightarrow F$ and $v : F \rightarrow Y$ with $F \in \mathcal{F}$ such that $\text{id}_Z = g'g + uv$. As $\text{Ext}_{\mathcal{E}'}^1(F, X) = 0$, there exists $v' : F \rightarrow Y$ such that $v = v'g$. Thus $\text{id}_Z = (g' + uv')g$ holds, and (3-1) splits in \mathcal{E}' . Therefore $\text{Ext}_{\mathcal{E}'}^1(Z, X) \rightarrow \text{Ext}_{\mathcal{E}'/[\mathcal{F}]}^1(\pi Z, \pi X)$ is injective. \square

In the rest of this section we give sufficient conditions for **Theorem 3.6(ii)** to hold. For two subcategories \mathcal{B} and \mathcal{C} of \mathcal{E} , we denote by $\mathcal{C} \searrow \mathcal{B}$ the full subcategory of \mathcal{E} consisting of X such that for any complex $Y \xrightarrow{g} B \xrightarrow{f} X$ with $B \in \mathcal{B}$ and $Y \in \mathcal{E}'$, there exists a morphism of complexes

$$\begin{array}{ccccc} Y & \xrightarrow{g} & B & \xrightarrow{f} & X \\ \downarrow & & \downarrow & & \parallel \\ C & \xrightarrow{g'} & B' & \xrightarrow{f'} & X \end{array}$$

with $B' \in \mathcal{B}$ and $C \in \mathcal{C}$. Notice that, if $X \in \mathcal{E}$ has a right \mathcal{B} -approximation whose pseudo-kernel is in \mathcal{C} , then $X \in [\mathcal{C} \searrow \mathcal{B}]$. Also notice that $[\mathcal{E}' \searrow \mathcal{B}] = \mathcal{E}$ holds since we can choose $f' = f$ and $g' = g$. Dually, we denote by $\mathcal{B} \nearrow \mathcal{C}$ the full subcategory of \mathcal{E} consisting of X such that for any complex $X \xrightarrow{f} B \xrightarrow{g} Y$ with $B \in \mathcal{B}$ and $Y \in \mathcal{E}'$, there exists a morphism of complexes

$$\begin{array}{ccccc} X & \longrightarrow & B' & \longrightarrow & C \\ \parallel & & \downarrow & & \downarrow \\ X & \xrightarrow{f} & B & \xrightarrow{g} & Y \end{array}$$

with $B' \in \mathcal{B}$ and $C \in \mathcal{C}$. As before, if $X \in \mathcal{E}$ has a left \mathcal{B} -approximation whose pseudo-cokernel is in \mathcal{C} , then $X \in [\mathcal{B} \nearrow \mathcal{C}]$. Also, we get $[\mathcal{B} \nearrow \mathcal{E}'] = \mathcal{E}$. We get the following corollary:

Corollary 3.7. *Let \mathcal{P} and \mathcal{I} be the full subcategories of \mathcal{E} consisting of objects X satisfying $\text{Ext}_{\mathcal{E}}^1(X, \mathcal{E}') = 0$ and $\text{Ext}_{\mathcal{E}}^1(\mathcal{E}', X) = 0$ respectively. If*

$$\mathcal{E}' \subset (\mathcal{F} \nearrow [\mathcal{I} \searrow \mathcal{F}]) \cap ([\mathcal{F} \nearrow \mathcal{P}] \searrow \mathcal{F})$$

then $(\mathcal{E}'/[F], \mathcal{S}'_{\mathcal{F}})$ is an exact category.

Proof. We need to prove [Theorem 3.6\(ii\)](#). We do it for admissible monomorphisms. Let $0 \rightarrow X \xrightarrow{f} Y \xrightarrow{g} Z \rightarrow 0$ be a short exact sequence in \mathcal{S}' , and let $u : X' \rightarrow X$ be a morphism such that $\bar{u}\bar{f} = 0$ in $\mathcal{E}'/[F]$. Then $uf = f'u'$ holds for some $f' : X' \rightarrow F'$ and $u' : F' \rightarrow Y$ with $F' \in \mathcal{F}$.

Suppose first that $X' \in [\mathcal{F} \nearrow \mathcal{P}]$. By definition, we can complete a commutative diagram

$$\begin{array}{ccccccc} X' & \xrightarrow{\alpha} & F & \xrightarrow{\beta} & P & & \\ \parallel & & \downarrow v' & & \downarrow v'' & & \\ X' & \xrightarrow{f'} & F' & \xrightarrow{u'g} & Z & & \\ u \downarrow & & \downarrow u' & & \parallel & & \\ 0 & \longrightarrow & X & \xrightarrow{f} & Y & \xrightarrow{g} & Z \longrightarrow 0 \end{array}$$

with $\alpha\beta = 0$ and $F \in \mathcal{F}$ and $P \in \mathcal{P}$. As $\text{Ext}_{\mathcal{E}}^1(P, X) = 0$, we know $v'' = g''g$ for some $g'' : P \rightarrow Y$ and we easily get $v'u' = \beta g'' + f''f$ for some $f'' : F \rightarrow X$. We deduce that $\alpha f''f = \alpha v'u' - \alpha\beta g'' = uf$. As f is a monomorphism, $\alpha f'' = u$ and therefore $\bar{u} = 0$.

Let us now suppose that $X' \in \mathcal{E}'$. As $Z \in ([\mathcal{F} \nearrow \mathcal{P}] \searrow \mathcal{F})$, we can complete the following commutative diagram

$$\begin{array}{ccccccc} A & \xrightarrow{\alpha} & F & \xrightarrow{\beta} & Z & & \\ v \uparrow & & \uparrow v' & & \parallel & & \\ X' & \xrightarrow{f'} & F' & \xrightarrow{u'g} & Z & & \\ u \downarrow & & \downarrow u' & & \parallel & & \\ 0 & \longrightarrow & X & \xrightarrow{f} & Y & \xrightarrow{g} & Z \longrightarrow 0 \end{array}$$

with $\alpha\beta = 0$ and $F \in \mathcal{F}$ and $A \in [\mathcal{F} \nearrow \mathcal{P}]$. Then, as $\text{Ext}_{\mathcal{E}}^1(F, X) = 0$, we get $\beta = \beta'g$ with $\beta' : F \rightarrow Y$ and, as f is the kernel of g , there exists $\alpha' : A \rightarrow X$ such that $\alpha\beta' = \alpha'f$. As $A \in [\mathcal{F} \nearrow \mathcal{P}]$ and $\bar{\alpha}'\bar{f} = 0$, by the first part of the argument, $\bar{\alpha}' = 0$. On the other hand, by an easy diagram chase, there exists $w : F' \rightarrow X$ such that $u' = v'\beta' + wf$. So we get $uf = f'u' = f'v'\beta' + f'wf = v\alpha\beta' + f'wf = v\alpha'f + f'wf$. As f is a monomorphism, we deduce that $u = v\alpha' + f'w$. Thus $\bar{u} = 0$ holds since $\bar{\alpha}' = 0$. \square

In the rest of this section, we give three special cases as an application. Notice that the first case recovers Chen’s result [2012, Theorem 3.1] for $\mathcal{E}' = \mathcal{E}$.

Corollary 3.8. (a) *If, for any $X \in \mathcal{E}'$, there exist left and right \mathcal{F} -approximations f and f' and pseudo-cokernel g and pseudo-kernel g'*

$$X \xrightarrow{f} F^X \xrightarrow{g} P^X \quad \text{and} \quad I_X \xrightarrow{g'} F_X \xrightarrow{f'} X$$

such that $P^X \in \mathcal{P}$ and $I_X \in \mathcal{I}$ then $(\mathcal{E}' / [\mathcal{F}], \mathcal{S}'_{\mathcal{F}})$ is an exact category.

(b) *If, for any $X \in \mathcal{E}'$, there exists a left \mathcal{F} -approximation $X \rightarrow F^X$ which is a categorical epimorphism, then $(\mathcal{E}' / [\mathcal{F}], \mathcal{S}'_{\mathcal{F}})$ is an exact category.*

(c) *If, for any $X \in \mathcal{E}'$, there exists a right \mathcal{F} -approximation $F_X \rightarrow X$ which is a categorical monomorphism, then $(\mathcal{E}' / [\mathcal{F}], \mathcal{S}'_{\mathcal{F}})$ is an exact category.*

Proof. (a) Let $X \rightarrow F \rightarrow Y$ be a complex where $X, Y \in \mathcal{E}'$ and $F \in \mathcal{F}$. It is easy to complete the following commutative diagram

$$\begin{array}{ccccc} X & \longrightarrow & F^X & \longrightarrow & P^X \\ \parallel & & \downarrow & & \downarrow \\ X & \longrightarrow & F & \longrightarrow & Y \end{array}$$

so $\mathcal{E}' \subset [\mathcal{F} \nearrow \mathcal{P}]$. Thus we have $\mathcal{E} = [\mathcal{E}' \searrow \mathcal{F}] \subset ([\mathcal{F} \nearrow \mathcal{P}] \searrow \mathcal{F})$. Dually we have $\mathcal{E} = (\mathcal{F} \nearrow [\mathcal{I} \searrow \mathcal{F}])$.

(b) By the same argument as the beginning of (a), we get $\mathcal{E}' \subset [\mathcal{F} \nearrow 0]$. So

$$\mathcal{E}' \subset [\mathcal{F} \nearrow 0] \subset (\mathcal{F} \nearrow [\mathcal{I} \searrow \mathcal{F}]) \quad \text{and} \quad \mathcal{E} = [\mathcal{E}' \searrow \mathcal{F}] \subset ([\mathcal{F} \nearrow 0] \searrow \mathcal{F}) \subset ([\mathcal{F} \nearrow \mathcal{P}] \searrow \mathcal{F}).$$

(c) This is the dual of (b). □

3C. On some Frobenius subcategories of exact categories. When we have an admissible monomorphism $f : X \rightarrow Y$ in an exact category, we say X is an *admissible subobject* of Y . Dually we define an *admissible factor object*. For a full subcategory \mathcal{E}' of an exact category \mathcal{E} , we denote by $\text{Sub } \mathcal{E}'$ the smallest full subcategory of \mathcal{E} which is closed under admissible subobjects and contains $\text{add } \mathcal{E}'$.

We recall that an exact category is *Frobenius* if it has enough injective objects, enough projective objects and they coincide. This subsection is devoted to proving the following result.

Proposition 3.9. *Let \mathcal{E} be an exact category which has enough projective objects and enough injective objects. Let \mathcal{U} be a subcategory of injective objects in \mathcal{E} satisfying $\mathcal{U} = \text{add } \mathcal{U}$, and let $\mathcal{D} := \text{Sub } \mathcal{U}$. Assume that projective objects of \mathcal{E} and those of \mathcal{D} coincide. Then the following assertions hold:*

(a) *\mathcal{D} is closed under extensions.*

(b) \mathcal{D} is Frobenius if and only if the following conditions are satisfied:

- U is projective-injective in \mathcal{E} for any $U \in \mathcal{U}$.
- Each projective object of \mathcal{E} has injective dimension at most 1 and each injective object of \mathcal{E} has projective dimension at most 1.

(c) If the conditions in (b) are satisfied, then \mathcal{U} is the category of projective-injective objects in \mathcal{E} .

Part (a) is an easy consequence of the horseshoe lemma. Let us start with the following lemma:

Lemma 3.10. Assume any object in \mathcal{U} is projective in \mathcal{E} . Let $0 \rightarrow E \rightarrow E' \xrightarrow{f} I \rightarrow 0$ be an exact sequence in \mathcal{E} with I injective. Then

$$\text{Hom}_{\mathcal{E}}(\mathcal{D}, f) : \text{Hom}_{\mathcal{E}}(\mathcal{D}, E') \rightarrow \text{Hom}_{\mathcal{E}}(\mathcal{D}, I)$$

is an epimorphism.

Proof. Take a morphism $g : D \rightarrow I$ with $D \in \mathcal{D}$. Then there exists an admissible monomorphism $i : D \rightarrow U$ with $U \in \mathcal{U}$. Since I is injective in \mathcal{E} , there exists $s : U \rightarrow I$ such that $g = is$. Since U is projective in \mathcal{E} , there exists $t : U \rightarrow E'$ such that $s = tf$:

$$\begin{array}{ccccccc}
 0 & \longrightarrow & E & \longrightarrow & E' & \xrightarrow{f} & I & \longrightarrow & 0 \\
 & & & & \swarrow & & \uparrow s \\
 & & & & D & \xrightarrow{i} & U & & \\
 & & & & \nearrow g & & \nwarrow t & &
 \end{array}$$

Since $g = itf$, we have the assertion. □

Let us now prove the proposition.

Proof of Proposition 3.9(b). “ \Rightarrow ” Suppose that \mathcal{D} is Frobenius. Note that our assumptions imply that projective objects in \mathcal{E} , projective objects in \mathcal{D} and injective objects in \mathcal{D} coincide.

Fix any $U \in \mathcal{U}$. Then U is injective in \mathcal{E} by our assumption, and hence U is injective also in \mathcal{D} . Therefore U is projective in \mathcal{E} by the remark above.

Let P be a projective object in \mathcal{E} . Then P is projective-injective in \mathcal{D} . Since our assumptions imply $\Omega_{\mathcal{E}}(\mathcal{E}) \subset \mathcal{D}$, we have

$$\text{Ext}_{\mathcal{E}}^2(\mathcal{E}, P) = \text{Ext}_{\mathcal{E}}^1(\Omega_{\mathcal{E}}(\mathcal{E}), P) = 0.$$

Thus P has injective dimension at most 1 in \mathcal{E} .

Let I be an injective object in \mathcal{E} . We take an exact sequence

$$0 \rightarrow \Omega_{\mathcal{E}}(I) \rightarrow P \xrightarrow{f} I \rightarrow 0 \tag{3-2}$$

with a projective object P in \mathcal{E} . Our assumptions imply $P \in \mathcal{D}$ and $\Omega_{\mathcal{E}}(I) \in \mathcal{D}$. We apply $\text{Hom}_{\mathcal{E}}(\mathcal{D}, -)$ to (3-2) to get the exact sequence

$$\text{Hom}_{\mathcal{E}}(\mathcal{D}, P) \rightarrow \text{Hom}_{\mathcal{E}}(\mathcal{D}, I) \rightarrow \text{Ext}_{\mathcal{E}}^1(\mathcal{D}, \Omega_{\mathcal{E}}(I)) \rightarrow \text{Ext}_{\mathcal{E}}^1(\mathcal{D}, P) = 0.$$

By Lemma 3.10, we have $\text{Ext}_{\mathcal{E}}^1(\mathcal{D}, \Omega_{\mathcal{E}}(I)) = 0$. Thus $\Omega_{\mathcal{E}}(I)$ is projective-injective in \mathcal{D} so projective in \mathcal{E} , and the assertion follows.

“ \Leftarrow ” Let P be a projective object in \mathcal{D} . By our assumptions, P is projective in \mathcal{E} , and there exists an exact sequence $0 \rightarrow P \rightarrow I^0 \rightarrow I^1 \rightarrow 0$ with injective objects I^0, I^1 in \mathcal{E} . Applying $\text{Hom}_{\mathcal{E}}(\mathcal{D}, -)$, we have an exact sequence

$$\text{Hom}_{\mathcal{E}}(\mathcal{D}, I^0) \rightarrow \text{Hom}_{\mathcal{E}}(\mathcal{D}, I^1) \rightarrow \text{Ext}_{\mathcal{E}}^1(\mathcal{D}, P) \rightarrow \text{Ext}_{\mathcal{E}}^1(\mathcal{D}, I^0) = 0.$$

By Lemma 3.10, we have $\text{Ext}_{\mathcal{E}}^1(\mathcal{D}, P) = 0$. Thus P is injective in \mathcal{D} .

Let I be an injective object in \mathcal{D} . Since $\Omega_{\mathcal{E}}(\mathcal{E}) \subset \mathcal{D}$, we have $\text{Ext}_{\mathcal{E}}^2(\mathcal{E}, I) = \text{Ext}_{\mathcal{E}}^1(\Omega_{\mathcal{E}}(\mathcal{E}), I) = 0$. Thus I has injective dimension at most 1 in \mathcal{E} . Now we take an exact sequence

$$0 \rightarrow I \rightarrow U \rightarrow E \rightarrow 0 \tag{3-3}$$

with $U \in \mathcal{U}$ and $E \in \mathcal{E}$. Since U is injective in \mathcal{E} , so is E . Thus E has projective dimension at most 1 in \mathcal{E} . Since U is projective in \mathcal{E} , so is I . Thus I is projective in \mathcal{D} .

Since \mathcal{E} has enough projective objects and $\Omega_{\mathcal{E}}(\mathcal{E}) \subset \mathcal{D}$ holds, \mathcal{D} also has enough projective objects. It remains to prove that \mathcal{D} has enough injective objects. Fix $D \in \mathcal{D}$ and take an exact sequence $0 \rightarrow D \rightarrow U \rightarrow E \rightarrow 0$ with $U \in \mathcal{U}$ and $E \in \mathcal{E}$. Since \mathcal{E} has enough injective objects by our assumption, there exists an exact sequence $0 \rightarrow E \rightarrow I \rightarrow E' \rightarrow 0$ with an injective object I in \mathcal{E} and $E' \in \mathcal{E}$. Let $0 \rightarrow P_1 \rightarrow P_0 \rightarrow I \rightarrow 0$ be a projective resolution of I in \mathcal{E} . We have a commutative diagram of exact sequences:

$$\begin{array}{ccccccc}
 & & & 0 & & 0 & \\
 & & & \downarrow & & \downarrow & \\
 0 & \longrightarrow & P_1 & \longrightarrow & X & \longrightarrow & E \longrightarrow 0 \\
 & & \parallel & & \downarrow & & \downarrow \\
 0 & \longrightarrow & P_1 & \longrightarrow & P_0 & \longrightarrow & I \longrightarrow 0 \\
 & & & & \downarrow & & \downarrow \\
 & & & & E' & \xlongequal{\quad} & E' \\
 & & & & \downarrow & & \downarrow \\
 & & & & 0 & & 0
 \end{array}$$

Since $P_0 \in \mathcal{D}$, the middle column shows $X \in \mathcal{D}$. On the other hand, we have the following commutative diagram of exact sequences:

$$\begin{array}{ccccccc}
 & & & 0 & & 0 & \\
 & & & \downarrow & & \downarrow & \\
 & & & P_1 & \xlongequal{\quad} & P_1 & \\
 & & & \downarrow & & \downarrow & \\
 0 & \longrightarrow & D & \longrightarrow & Y & \longrightarrow & X \longrightarrow 0 \\
 & & \parallel & & \downarrow & & \downarrow & \\
 0 & \longrightarrow & D & \longrightarrow & U & \longrightarrow & E \longrightarrow 0 \\
 & & & & \downarrow & & \downarrow & \\
 & & & & 0 & & 0 &
 \end{array}$$

As P_1 is projective-injective in \mathcal{D} , the middle column splits and $Y \cong U \oplus P_1$ is injective in \mathcal{D} . The middle row gives an injective hull of D in \mathcal{D} . \square

Proof of Proposition 3.9(c). Let P be a projective-injective object in \mathcal{E} . Then it belongs to \mathcal{D} , and there is a short exact sequence $0 \rightarrow P \rightarrow U \rightarrow E \rightarrow 0$ with $U \in \mathcal{U}$ and $E \in \mathcal{E}$. Since P is injective in \mathcal{E} , this sequence splits. Thus P belongs to \mathcal{U} . \square

4. Equivalences arising from torsion pairs on exact categories

Throughout this section, we assume the following:

- \mathcal{E} is an exact category which is Krull–Schmidt.
- $(\mathcal{A}, \mathcal{B})$ is a *torsion pair* of \mathcal{E} ; that is, the following conditions are satisfied:
 - \mathcal{A} and \mathcal{B} are full subcategories of \mathcal{E} such that $\text{Hom}_{\mathcal{E}}(\mathcal{A}, \mathcal{B}) = 0$.
 - For any $E \in \mathcal{E}$, there exists an exact sequence $0 \rightarrow A \rightarrow E \rightarrow B \rightarrow 0$ with $A \in \mathcal{A}$ and $B \in \mathcal{B}$.

Then \mathcal{A} is closed under taking extensions and admissible factor objects, and \mathcal{B} is closed under taking extensions and admissible subobjects. On the other hand, the natural inclusion functor $\mathcal{B} \rightarrow \mathcal{E}$ has a left adjoint functor $F : \mathcal{E} \rightarrow \mathcal{B}$. This is dense and induces a dense functor

$$F : \mathcal{E}/[\mathcal{A}] \rightarrow \mathcal{B}.$$

4A. Basic properties of $F : \mathcal{E}/[\mathcal{A}] \rightarrow \mathcal{B}$. We consider the full subcategories of \mathcal{E} defined by

$$\begin{aligned}
 \mathcal{E}_1 &= \{X \in \mathcal{E} \mid \text{Ext}_{\mathcal{E}}^1(X, \mathcal{A}) = 0\}, \\
 \mathcal{E}_2 &= \{X \in \mathcal{E} \mid \text{Ext}_{\mathcal{E}}^1(X, \mathcal{A}) = 0, \text{Ext}_{\mathcal{E}}^2(X, \mathcal{A}) = 0\}.
 \end{aligned}$$

The subsection is devoted to proving the following result:

Theorem 4.1. *We have the following assertions:*

- (a) *The functor $F : \mathcal{E}_1/[\mathcal{A}] \rightarrow \mathcal{B}$ is fully faithful.*
- (b) *The essential image of $F : \mathcal{E}_1/[\mathcal{A}] \rightarrow \mathcal{B}$ is the subcategory consisting of $B \in \mathcal{B}$ such that $\text{Ext}_{\mathcal{E}}^1(B, \mathcal{A})$ is a finitely generated \mathcal{A}^{op} -module.*
- (c) *If $\text{Ext}_{\mathcal{E}}^1(\mathcal{A}, \mathcal{B}) = 0$, then $F : \mathcal{E}_2 \rightarrow \mathcal{B}$ is exact bijective.*
- (d) *If any object in \mathcal{A} is projective in \mathcal{E} , then $\mathcal{E}_2/[\mathcal{A}]$ inherits canonically the exact structure of \mathcal{E}_2 and $F : \mathcal{E}_2/[\mathcal{A}] \rightarrow \mathcal{B}$ is exact bijective.*

We denote by $T : \mathcal{E} \rightarrow \mathcal{A}$ the right adjoint functor of the inclusion functor $\mathcal{A} \rightarrow \mathcal{E}$. Then for any $E \in \mathcal{E}$, there exists a short exact sequence

$$0 \rightarrow TE \xrightarrow{f} E \xrightarrow{g} FE \rightarrow 0$$

in \mathcal{E} with $TE \in \mathcal{A}$ and $FE \in \mathcal{B}$. Clearly f is a right \mathcal{A} -approximation and g is a left \mathcal{B} -approximation.

The proof of [Theorem 4.1](#) is divided into [Lemmas 4.2, 4.3, 4.5](#) and [4.6](#).

Lemma 4.2. *The functor $F : \mathcal{E}_1 \rightarrow \mathcal{B}$ induces a fully faithful functor $F : \mathcal{E}_1/[\mathcal{A}] \rightarrow \mathcal{B}$.*

Proof. Fix $X, Y \in \mathcal{E}_1$. By applying $\text{Hom}_{\mathcal{E}}(X, -)$ to the short exact sequence $0 \rightarrow TY \rightarrow Y \rightarrow FY \rightarrow 0$, we obtain the short exact sequence

$$0 \rightarrow \text{Hom}_{\mathcal{E}}(X, TY) \rightarrow \text{Hom}_{\mathcal{E}}(X, Y) \rightarrow \text{Hom}_{\mathcal{E}}(X, FY) \rightarrow \text{Ext}_{\mathcal{E}}^1(X, TY) = 0,$$

where the last equality follows from $X \in \mathcal{E}_1$. So

$$\text{Hom}_{\mathcal{E}}(X, FY) \cong \frac{\text{Hom}_{\mathcal{E}}(X, Y)}{\text{Hom}_{\mathcal{E}}(X, TY)} = \text{Hom}_{\mathcal{E}/[\mathcal{A}]}(X, Y),$$

where we use the fact that the first arrow of $TY \rightarrow Y$ is a right \mathcal{A} -approximation. On the other hand, using adjunction we have an isomorphism

$$\text{Hom}_{\mathcal{E}}(FX, FY) \cong \text{Hom}_{\mathcal{E}}(X, FY).$$

Thus the assertion follows. □

Next we prove the following observation.

Proposition 4.3. *The following conditions are equivalent for $B \in \mathcal{B}$:*

- (i) *B belongs to the essential image of $F : \mathcal{E}_1 \rightarrow \mathcal{B}$.*
- (ii) *$\text{Ext}_{\mathcal{E}}^1(B, \mathcal{A})$ is a finitely generated \mathcal{A}^{op} -module.*

This follows immediately from the following result for Krull–Schmidt exact categories, which is a generalization of [\[Auslander and Reiten 1991, Proposition 1.4\]](#).

Lemma 4.4. *Let \mathcal{X} be a Krull–Schmidt exact category, and \mathcal{Y} a subcategory of \mathcal{X} which is closed under extensions and direct summands. For $X \in \mathcal{X}$, the following conditions are equivalent:*

- (i) *There exists an exact sequence $0 \rightarrow Y \rightarrow Z \rightarrow X \rightarrow 0$ with $Y \in \mathcal{Y}$ and $\text{Ext}_{\mathcal{X}}^1(Z, \mathcal{Y}) = 0$.*
- (ii) *$\text{Ext}_{\mathcal{X}}^1(X, \mathcal{Y})$ is finitely generated \mathcal{Y}^{op} -module.*

We include a proof for the convenience of the reader.

Proof. (i) \Rightarrow (ii): Applying $\text{Hom}_{\mathcal{X}}(-, \mathcal{Y})$ to the short exact sequence $0 \rightarrow Y \rightarrow Z \rightarrow X \rightarrow 0$, we obtain the exact sequence

$$\text{Hom}_{\mathcal{X}}(Y, \mathcal{Y}) \rightarrow \text{Ext}_{\mathcal{X}}^1(X, \mathcal{Y}) \rightarrow \text{Ext}_{\mathcal{X}}^1(Z, \mathcal{Y}) = 0.$$

Thus $\text{Ext}_{\mathcal{X}}^1(X, \mathcal{Y})$ is a finitely generated \mathcal{Y}^{op} -module.

(ii) \Rightarrow (i): There exists a projective cover $\varphi : \text{Hom}_{\mathcal{X}}(Y, \mathcal{Y}) \rightarrow \text{Ext}_{\mathcal{X}}^1(X, \mathcal{Y})$ since \mathcal{Y} is Krull–Schmidt. Let

$$0 \rightarrow Y \xrightarrow{f} Z \xrightarrow{g} X \rightarrow 0$$

be a short exact sequence represented by $\varphi(\text{id}_Y) \in \text{Ext}_{\mathcal{X}}^1(X, Y)$. Since φ is right minimal, f belongs to $\text{rad } \mathcal{X}$, and hence g is right minimal. To prove $\text{Ext}_{\mathcal{X}}^1(Z, \mathcal{Y}) = 0$, it suffices to show that any exact sequence

$$0 \rightarrow Y' \rightarrow W \xrightarrow{s} Z \rightarrow 0 \tag{4-1}$$

with $Y' \in \mathcal{Y}$ splits. We have the following commutative diagram of exact sequences:

$$\begin{array}{ccccccccc}
 & & 0 & & 0 & & & & \\
 & & \downarrow & & \downarrow & & & & \\
 & & Y' & \xlongequal{\quad} & Y' & & & & \\
 & & \downarrow & & \downarrow & & & & \\
 0 & \longrightarrow & Y'' & \longrightarrow & W & \longrightarrow & X & \longrightarrow & 0 \\
 & & \downarrow & & \downarrow^s & & \parallel & & \\
 0 & \longrightarrow & Y & \xrightarrow{f} & Z & \xrightarrow{g} & X & \longrightarrow & 0 \\
 & & \downarrow & & \downarrow & & & & \\
 & & 0 & & 0 & & & &
 \end{array}$$

where $Y'' \in \mathcal{Y}$ because \mathcal{Y} is extension-closed. As φ is an epimorphism, we have the following commutative diagram of exact sequences:

$$\begin{array}{ccccccccc}
 0 & \longrightarrow & Y & \xrightarrow{f} & Z & \xrightarrow{g} & X & \longrightarrow & 0 \\
 & & \downarrow & & \downarrow^t & & \parallel & & \\
 0 & \longrightarrow & Y'' & \longrightarrow & W & \longrightarrow & X & \longrightarrow & 0
 \end{array}$$

As g is right minimal, $ts : Z \rightarrow Z$ is invertible. Therefore the sequence (4-1) splits. \square

Lemma 4.5. *Suppose that $\text{Ext}_{\mathcal{E}}^1(\mathcal{A}, \mathcal{B}) = 0$. Then the functor $F : \mathcal{E}_2 \rightarrow \mathcal{B}$ is exact bijective.*

Proof. Let $X, Y \in \mathcal{E}_2$. By applying $\text{Hom}_{\mathcal{E}}(X, -)$ to the short exact sequence $0 \rightarrow TY \rightarrow Y \rightarrow FY \rightarrow 0$, we have the isomorphism

$$\text{Ext}_{\mathcal{E}}^1(X, Y) \cong \text{Ext}_{\mathcal{E}}^1(X, FY),$$

as $\text{Ext}_{\mathcal{E}}^i(X, TY) = 0$ holds for $i = 1, 2$. Applying $\text{Hom}_{\mathcal{E}}(-, FY)$ to the short exact sequence $0 \rightarrow TX \rightarrow X \rightarrow FX \rightarrow 0$, we have an isomorphism

$$\text{Ext}_{\mathcal{E}}^1(FX, FY) \cong \text{Ext}_{\mathcal{E}}^1(X, FY)$$

as $\text{Ext}_{\mathcal{E}}^i(TX, FY) = 0$ holds for $i = 0, 1$. Thus we have

$$\text{Ext}_{\mathcal{B}}^1(FX, FY) = \text{Ext}_{\mathcal{E}}^1(FX, FY) \cong \text{Ext}_{\mathcal{E}}^1(X, Y). \quad \square$$

Lemma 4.6. *Suppose that any object in \mathcal{A} is projective in \mathcal{E} . Then $\mathcal{E}_2/[\mathcal{A}]$ inherits canonically the exact structure of \mathcal{E}_2 , and the functor $F : \mathcal{E}_2/[\mathcal{A}] \rightarrow \mathcal{B}$ is exact bijective.*

Proof. Any object $X \in \mathcal{E}$ has a right \mathcal{A} -approximation $TX \rightarrow X$ which is a categorical monomorphism, and we have

$$\text{Ext}_{\mathcal{E}}^1(\mathcal{A}, \mathcal{E}_2) = \text{Ext}_{\mathcal{E}}^1(\mathcal{E}_2, \mathcal{A}) = 0$$

by our assumptions. Therefore [Corollary 3.8\(c\)](#) gives an exact structure on $\mathcal{E}_2/[\mathcal{A}]$. Applying [Lemma 4.5](#), we have

$$\text{Ext}_{\mathcal{B}}^1(FX, FY) \cong \text{Ext}_{\mathcal{E}_2}^1(X, Y) = \text{Ext}_{\mathcal{E}_2/[\mathcal{A}]}^1(X, Y),$$

which shows the assertion. □

4B. When there is a torsion pair $(\mathcal{B}, \mathcal{C})$. In this subsection, we further assume $(\mathcal{B}, \mathcal{C})$ is a torsion pair in \mathcal{E} for

$$\mathcal{C} := \{X \in \mathcal{E} \mid \text{Hom}_{\mathcal{E}}(\mathcal{B}, X) = 0\}.$$

The following result gives a description of the image of the functor $F : \mathcal{C} \rightarrow \mathcal{B}$.

Theorem 4.7. *Assume that the following conditions are satisfied:*

- \mathcal{B} is an abelian category whose exact structure is compatible with that of \mathcal{E} .
- $\text{Ext}_{\mathcal{E}}^1(\mathcal{B}, A)$ is a finitely generated \mathcal{B} -module for any $A \in \mathcal{A} \cap \mathcal{C}$.

Then we have the following assertions.

- (a) *For any $A \in \mathcal{A} \cap \mathcal{C}$, there exists a short exact sequence*

$$0 \rightarrow A \rightarrow C^A \rightarrow U^A \rightarrow 0$$

with $U^A \in \mathcal{B}$, $C^A \in \mathcal{C}$ and $\text{Ext}_{\mathcal{E}}^1(\mathcal{B}, C^A) = 0$. Moreover, it is unique up to isomorphism.

(b) Let $\mathcal{D} := \text{Sub}\{U^A \mid A \in \mathcal{A} \cap \mathcal{C}\}$. Then $F : \mathcal{E} \rightarrow \mathcal{B}$ induces a dense functor $F : \mathcal{C} \rightarrow \mathcal{D}$.

Assume $\text{Ext}_{\mathcal{E}}^2(\mathcal{B}, \mathcal{A} \cap \mathcal{C}) = 0$.

- (c) U^A is an injective object in \mathcal{B} for any $A \in \mathcal{A} \cap \mathcal{C}$.
- (d) \mathcal{D} is closed under taking extensions in \mathcal{E} , and therefore forms an exact category.
- (e) Assume $\mathcal{C} \subset \mathcal{E}_2$ and that any object in \mathcal{A} is projective in \mathcal{E} . Then $\mathcal{C}/[\mathcal{A}]$ inherits canonically the exact structure of \mathcal{C} and $F : \mathcal{C}/[\mathcal{A}] \rightarrow \mathcal{D}$ is an equivalence of exact categories.

Proof. (a) By the dual of [Lemma 4.4](#), we get a short exact sequence

$$0 \rightarrow A \xrightarrow{f} X \xrightarrow{g} U^A \rightarrow 0$$

for some $U^A \in \mathcal{B}$ such that $\text{Ext}_{\mathcal{E}}^1(\mathcal{B}, X) = 0$ and with f left minimal. We only have to prove $X \in \mathcal{C}$. Since $(\mathcal{B}, \mathcal{C})$ is a torsion pair, there exists an exact sequence

$$0 \rightarrow B \xrightarrow{i} X \rightarrow C \rightarrow 0$$

with $B \in \mathcal{B}$ and $C \in \mathcal{C}$. Now we consider the following commutative diagram, where $\text{Ker } ig$ exists in \mathcal{B} by our assumption:

$$\begin{array}{ccccccccc} 0 & \longrightarrow & A & \longrightarrow & X & \xrightarrow{g} & U^A & \longrightarrow & 0 \\ & & \uparrow & & \uparrow i & & \parallel & & \\ 0 & \longrightarrow & \text{Ker } ig & \longrightarrow & B & \xrightarrow{ig} & U^A & & \end{array}$$

Since $A \in \mathcal{C}$, we have $\text{Ker } ig = 0$. Thus ig is a monomorphism, and we can form the following commutative diagram with $\text{Coker } ig \in \mathcal{B}$ by our assumption:

$$\begin{array}{ccccccccc} & & & & 0 & & 0 & & \\ & & & & \downarrow & & \downarrow & & \\ & & & & B & \xlongequal{\quad} & B & & \\ & & & & \downarrow i & & \downarrow ig & & \\ 0 & \longrightarrow & A & \xrightarrow{f} & X & \xrightarrow{g} & U^A & \longrightarrow & 0 \\ & & \parallel & & \downarrow & & \downarrow p & & \\ 0 & \longrightarrow & A & \longrightarrow & C & \longrightarrow & \text{Coker } ig & \longrightarrow & 0 \\ & & & & \downarrow & & \downarrow & & \\ & & & & 0 & & 0 & & \end{array}$$

The upper horizontal sequence gives a projective cover $\varphi : \text{Hom}_{\mathcal{E}}(\mathcal{B}, U^A) \rightarrow \text{Ext}_{\mathcal{E}}^1(\mathcal{B}, A)$ (see the proof of [Lemma 4.4](#)). The lower horizontal sequence gives a morphism $\psi : \text{Hom}_{\mathcal{E}}(\mathcal{B}, \text{Coker } ig) \rightarrow \text{Ext}_{\mathcal{E}}^1(\mathcal{B}, A)$, which is an epimorphism since

$\varphi = \text{Hom}_{\mathcal{E}}(\mathcal{B}, p)\psi$. Since $\text{Coker } ig \in \mathcal{B}$ and φ is a projective cover, p has to be an isomorphism. Thus we have $B = 0$ and $X \cong C \in \mathcal{C}$.

As $\mathcal{B} \cap \mathcal{C} = 0$, the morphism $A \rightarrow C^A$ is left minimal and it implies easily the uniqueness.

(b) First we prove $F(\mathcal{C}) \subset \mathcal{D}$. For any $C \in \mathcal{C}$, there exists an exact sequence $0 \rightarrow A \rightarrow C \rightarrow B \rightarrow 0$ with $B = FC \in \mathcal{B}$ and $A = TC \in \mathcal{A}$. Clearly we have $A \in \mathcal{A} \cap \mathcal{C}$. Let $0 \rightarrow A \rightarrow C^A \rightarrow U^A \rightarrow 0$ be the exact sequence in (a). Then we have a commutative diagram

$$\begin{array}{ccccccc} 0 & \longrightarrow & A & \longrightarrow & C & \longrightarrow & B \longrightarrow 0 \\ & & \parallel & & \downarrow & & \downarrow f \\ 0 & \longrightarrow & A & \longrightarrow & C^A & \longrightarrow & U^A \longrightarrow 0 \end{array}$$

By our assumption, f has a kernel $g : \text{Ker } f \rightarrow B$ in \mathcal{E} with $\text{Ker } f \in \mathcal{B}$. Since the above diagram is pullback, g factors through $C \in \mathcal{C}$. Thus $g = 0$ holds, and hence f is a monomorphism. Therefore $0 \rightarrow B \xrightarrow{f} U^A \rightarrow \text{Coker } f \rightarrow 0$ is a short exact sequence in \mathcal{E} by our assumption, and $B \in \mathcal{D}$ holds.

Next we prove that the functor $F : \mathcal{B} \rightarrow \mathcal{D}$ is dense. For any $D \in \mathcal{D}$, there exist exact sequences

$$0 \rightarrow D \rightarrow U^A \rightarrow X \rightarrow 0 \quad \text{and} \quad 0 \rightarrow A \rightarrow C^A \rightarrow U^A \rightarrow 0$$

with $A \in \mathcal{A} \cap \mathcal{C}$, $U^A \in \mathcal{B}$, $C^A \in \mathcal{C}$ and $\text{Ext}_{\mathcal{E}}^1(\mathcal{B}, C^A) = 0$. Then we have a commutative diagram

$$\begin{array}{ccccccc} & & & & 0 & & 0 \\ & & & & \downarrow & & \downarrow \\ 0 & \longrightarrow & A & \longrightarrow & Y & \longrightarrow & D \longrightarrow 0 \\ & & \parallel & & \downarrow & & \downarrow \\ 0 & \longrightarrow & A & \longrightarrow & C^A & \longrightarrow & U^A \longrightarrow 0 \\ & & & & \downarrow & & \downarrow \\ & & & & X & \xlongequal{\quad} & X \\ & & & & \downarrow & & \downarrow \\ & & & & 0 & & 0 \end{array}$$

of exact sequences. Since $C^A \in \mathcal{C}$, we have $Y \in \mathcal{C}$ by the middle vertical sequence. Therefore $D = FY$ belongs to $F(\mathcal{C})$.

(c) Applying $\text{Hom}_{\mathcal{E}}(\mathcal{B}, -)$ to the short exact sequence $0 \rightarrow A \rightarrow C^A \rightarrow U^A \rightarrow 0$, we have an exact sequence

$$0 = \text{Ext}_{\mathcal{E}}^1(\mathcal{B}, C^A) \rightarrow \text{Ext}_{\mathcal{E}}^1(\mathcal{B}, U^A) \rightarrow \text{Ext}_{\mathcal{E}}^2(\mathcal{B}, A) = 0.$$

Therefore $\text{Ext}_{\mathcal{E}}^1(\mathcal{B}, U^A) = 0$; that is, U^A is injective in \mathcal{B} .

(d) This is an immediate consequence of (c) and the horseshoe lemma.

(e) By [Theorem 4.1\(a\)](#) and (d), the functor $F : \mathcal{E}_2/[A] \rightarrow \mathcal{B}$ is fully faithful and exact bijective. By $\mathcal{C} \subset \mathcal{E}_2$, using (b) and (d), we have an equivalence $F : \mathcal{C}/[A] \rightarrow \mathcal{D}$ of exact categories. \square

4C. Frobenius properties. As in [Section 4B](#), we suppose that $(\mathcal{B}, \mathcal{C})$ is a torsion pair. We define $\mathcal{U} := \text{add}\{U^A \mid A \in \mathcal{A} \cap \mathcal{C}\}$ and as in [Theorem 4.7](#), $\mathcal{D} := \text{Sub}\mathcal{U}$. The following result gives a sufficient condition for the categories \mathcal{C} and \mathcal{D} to be Frobenius.

Theorem 4.8. *Assume that the following conditions are satisfied:*

- \mathcal{B} is an abelian category whose exact structure is compatible with that of \mathcal{E} and has enough projective objects and enough injective objects.
- $\mathcal{A} \subset \mathcal{C}$ holds, and any object in \mathcal{A} is projective in \mathcal{E} and injective in \mathcal{C} .
- $\text{Ext}_{\mathcal{E}}^1(\mathcal{B}, A)$ is a finitely generated \mathcal{B} -module for any $A \in \mathcal{A}$.
- $\text{Ext}_{\mathcal{E}}^1(P, \mathcal{A})$ is a finitely generated \mathcal{A}^{op} -module for any projective object P in \mathcal{B} .

Then we have the following assertions:

- (a) \mathcal{E} has enough projective objects and enough injective objects. Moreover, the following conditions are equivalent:
- (i) Projective objects of \mathcal{B} and \mathcal{D} coincide.
 - (ii) Projective objects of \mathcal{C} and \mathcal{E} coincide.

Suppose that the equivalent conditions in (a) are satisfied. Then the following assertions hold:

- (b) \mathcal{C} and \mathcal{D} have enough projective objects.
- (c) Any object in \mathcal{A} has injective dimension at most 1 in \mathcal{E} . Therefore all assertions in [Theorem 4.7](#) hold.
- (d) The following conditions are equivalent:
- (i) \mathcal{C} is a Frobenius category whose exact structure is compatible with that of \mathcal{E} .
 - (ii) \mathcal{D} is a Frobenius category whose exact structure is compatible with that of \mathcal{E} .
 - (iii) Any object in \mathcal{U} is projective-injective in \mathcal{B} . Moreover, each projective object of \mathcal{B} has injective dimension at most 1 and each injective object of \mathcal{B} has projective dimension at most 1.
- (e) If the conditions in (d) are satisfied, then the category of projective-injective objects in \mathcal{B} is \mathcal{U} .

We start with preparing the following:

Lemma 4.9. *For any projective object P in \mathcal{B} , there exists a projective object X in \mathcal{E} such that $P = FX$.*

Proof. By Lemma 4.4, there exists a short exact sequence $0 \rightarrow A \rightarrow X \rightarrow P \rightarrow 0$ with $A \in \mathcal{A}$ and $\text{Ext}_{\mathcal{E}}^1(X, \mathcal{A}) = 0$. Applying $\text{Hom}_{\mathcal{E}}(-, \mathcal{B})$, we have an exact sequence

$$0 = \text{Ext}_{\mathcal{E}}^1(P, \mathcal{B}) \rightarrow \text{Ext}_{\mathcal{E}}^1(X, \mathcal{B}) \rightarrow \text{Ext}_{\mathcal{E}}^1(A, \mathcal{B}) = 0.$$

Thus $\text{Ext}_{\mathcal{E}}^1(X, \mathcal{B}) = 0$ holds. Since $\text{Ext}_{\mathcal{E}}^1(X, \mathcal{A}) = 0$, we have $\text{Ext}_{\mathcal{E}}^1(X, \mathcal{E}) = 0$. Thus X is a projective object in \mathcal{E} satisfying $P = FX$. \square

Now we are ready to prove Theorem 4.8.

Proof of Theorem 4.8. (a) For any $X \in \mathcal{E}$, there exists a short exact sequence $0 \rightarrow A \rightarrow X \rightarrow B \rightarrow 0$ with $A = TX \in \mathcal{A}$ and $B = FX \in \mathcal{B}$. Then A is projective in \mathcal{E} by our assumption. Thanks to the horseshoe lemma, to show that X has a projective cover in \mathcal{E} , it suffices to show that any $B \in \mathcal{B}$ has a projective cover in \mathcal{E} .

By our assumption, there exists a projective cover $f : P \rightarrow B$ in \mathcal{B} . By Lemma 4.9, there exists a projective cover $g : P' \rightarrow P$ in \mathcal{E} . Then the composition $gf : P' \rightarrow B$ gives a projective cover of B in \mathcal{E} .

In the same way, to prove that \mathcal{E} has enough injective objects, it is enough to prove that any $A \in \mathcal{A}$ and any $B \in \mathcal{B}$ admits an injective hull in \mathcal{E} . For $B \in \mathcal{B}$, it admits an injective hull I in \mathcal{B} . As $(\mathcal{A}, \mathcal{B})$ is a torsion pair in \mathcal{E} and $\text{Ext}_{\mathcal{E}}^1(\mathcal{A}, \mathcal{E}) = 0$, we know I is injective in \mathcal{E} . For $A \in \mathcal{A}$, the object C^A defined in Theorem 4.7(a) is an injective hull of A by the same argument. So we proved that \mathcal{E} has enough injective objects.

(ii) \Rightarrow (i): Suppose that projective objects of \mathcal{C} and \mathcal{E} coincide.

Let P be a projective object in \mathcal{B} . By Lemma 4.9, there exists a projective object X in \mathcal{E} such that $P = FX$. Since X belongs to \mathcal{C} by our assumption, we have $P \in F(\mathcal{C}) \subset \mathcal{D}$. Thus P is a projective object in \mathcal{D} .

Let P be a projective object in \mathcal{D} . Since \mathcal{B} has enough projective objects by our assumption, there exists a projective cover $f : X \rightarrow P$ in \mathcal{B} . Since X belongs to \mathcal{D} by the above argument, f splits. Thus P is projective in \mathcal{B} .

(i) \Rightarrow (ii): Suppose that projective objects of \mathcal{B} and \mathcal{D} coincide.

Let P be a projective object in \mathcal{E} . Let $0 \rightarrow X \rightarrow P' \xrightarrow{f} FP \rightarrow 0$ be an exact sequence with a projective object P' in \mathcal{B} . Then $P' \in \mathcal{D}$ by our assumption. By Theorem 4.7(b), there exists an exact sequence $0 \rightarrow A \xrightarrow{i} C \xrightarrow{p} P' \rightarrow 0$ with $A \in \mathcal{A}$ and $C \in \mathcal{C}$. Since $\text{Ext}_{\mathcal{E}}^1(C, \mathcal{A}) = 0$ holds by our assumption, we have a commutative diagram:

$$\begin{array}{ccccccc}
 0 & \longrightarrow & A \oplus TP & \xrightarrow{\begin{bmatrix} i & 0 \\ 0 & 1_{TP} \end{bmatrix}} & C \oplus TP & \xrightarrow{\begin{bmatrix} p \\ 0 \end{bmatrix}} & P' \longrightarrow 0 \\
 & & \begin{bmatrix} \alpha \\ 1_{TP} \end{bmatrix} \downarrow & & \downarrow \begin{bmatrix} \beta \\ u \end{bmatrix} & & \downarrow f \\
 0 & \longrightarrow & TP & \xrightarrow{u} & P & \xrightarrow{v} & FP \longrightarrow 0
 \end{array}$$

As $\begin{bmatrix} \alpha \\ 1_{TP} \end{bmatrix}$ and f are (admissible) epimorphisms, $\begin{bmatrix} \beta \\ u \end{bmatrix}$ is also one. Since P is projective in \mathcal{E} , we know $\begin{bmatrix} \beta \\ u \end{bmatrix}$ splits. Thus P is a direct summand of $C \oplus TP$, which belongs to \mathcal{C} by our assumption $TP \in \mathcal{A} \subset \mathcal{C}$.

Conversely, let Q be a projective object in \mathcal{C} . Let us consider its projective cover P in \mathcal{E} . We get the short exact sequence

$$0 \rightarrow \Omega_{\mathcal{E}} Q \rightarrow P \rightarrow Q \rightarrow 0.$$

According to the previous discussion, $P \in \mathcal{C}$. Thus, we get that $\Omega_{\mathcal{E}} Q \in \mathcal{C}$. Hence, as Q is projective in \mathcal{C} , the short exact sequence splits and Q is projective in \mathcal{E} .

(b) We now suppose that the conditions in (a) are satisfied. Since \mathcal{E} has enough projective objects which belong to \mathcal{C} , we get that \mathcal{C} has enough projective objects. By a similar argument, \mathcal{D} has enough projective objects.

(c) All projective objects of \mathcal{E} belong to \mathcal{C} by our assumption. Therefore $\Omega_{\mathcal{E}}(\mathcal{E}) \subset \mathcal{C}$ holds. Since any object in \mathcal{A} is injective in \mathcal{C} by our assumption, we have

$$\text{Ext}_{\mathcal{E}}^2(\mathcal{E}, \mathcal{A}) = \text{Ext}_{\mathcal{E}}^1(\Omega_{\mathcal{E}}(\mathcal{E}), \mathcal{A}) = 0.$$

Thus the first assertion follows. In particular we have $\text{Ext}_{\mathcal{E}}^2(\mathcal{B}, \mathcal{A} \cap \mathcal{C}) = 0$, and the second assertion follows.

(d)–(e) Thanks to Theorems 3.6 and 4.7(e), $F : \mathcal{C} \rightarrow \mathcal{C}/[\mathcal{A}] \rightarrow \mathcal{D}$ is exact bijective. So \mathcal{C} is Frobenius if and only if \mathcal{D} is Frobenius by Remark 3.3. Hence (i) \Leftrightarrow (ii) in (d) is proven. The remaining assertions follow by applying Proposition 3.9 to \mathcal{B} . \square

5. Equivalences arising from orders and their idempotents

As in Section 2A, let R be a complete discrete valuation ring and K be its field of fractions. Fix an R -order A . Consider functors

$$D_i := \text{Ext}_R^{1-i}(-, R) : \text{mod } A \leftrightarrow \text{mod } A^{\text{op}}$$

for $i = 0, 1$. They restrict to dualities

$$D_1 = \text{Hom}_R(-, R) : \text{CM } A \xleftrightarrow{\sim} \text{CM } A^{\text{op}} \quad \text{and} \quad D_0 = \text{Ext}_R^1(-, R) : \text{f.l. } A \xleftrightarrow{\sim} \text{f.l. } A^{\text{op}}$$

and satisfy $D_0(\text{CM } A) = D_1(\text{f.l. } A) = 0$. In view of the characterizations of $\text{CM } A$ given at the beginning of Section 2, it is immediate that $\text{CM } A$ admits the projective generator A and the injective cogenerator $D_1 A$. Since the injective resolution of the R -module R is given by $0 \rightarrow R \rightarrow K \rightarrow K/R \rightarrow 0$, we get an isomorphism $D_0 \cong \text{Hom}_R(-, K/R)$ on $\text{f.l. } A$. Recall the following useful lemma:

Lemma 5.1. *If $X \in \text{CM } A$, then we have a monomorphism $X \hookrightarrow X \otimes_R K$ and $\text{Ext}_A^1(\text{f.l. } A, X \otimes_R K) = 0$.*

Proof. For $Y \in \text{f.l. } A$, let $E := \text{Ext}_A^1(Y, X \otimes_R K)$. Since $X \otimes_R K$ is a K -vector space, so is E . Since Y is annihilated by some nonzero element in R , so is E . These imply $E = 0$. \square

For an object $X \in \text{CM } A$, let $\text{corad } X \in \text{CM } A$ be maximal among A -submodules Y of $X \otimes_R K$ such that $X \subset Y$ and Y/X is semisimple. We define $\text{cotop } X := (\text{corad } X)/X$. Notice that $X \otimes_R K$ is not finitely generated as an A -module (so $X \otimes_R K \notin \text{CM } A$) if $X \in \text{CM } A$ is nonzero. Notice also that $D_1(X \otimes_R K) = 0$.

We often use the following lemma:

Lemma 5.2. *Let $X \in \text{CM } A$. The following hold:*

- (a) *We have $\text{cotop } X = \text{soc}(X \otimes_R (K/R))$.*
- (b) *The functor D_1 induces an order-reversing bijection*

$$\{X \subset Y \subset X \otimes_R K \mid Y/X \in \text{f.l. } A\} \xleftarrow{1-1} \{Y' \subset D_1 X \mid (D_1 X)/Y' \in \text{f.l. } A^{\text{op}}\}.$$
- (c) *There are isomorphisms $\text{corad } X \cong D_1 \text{rad } D_1 X$ and $\text{cotop } X \cong D_0 \text{top } D_1 X$ of A -modules.*
- (d) *If $0 \rightarrow X \rightarrow Y \rightarrow S \rightarrow 0$ is a short exact sequence with $Y \in \text{CM } A$ and a semisimple A -module S , then there is a unique canonical commutative diagram*

$$\begin{array}{ccccccc}
 0 & \longrightarrow & X & \longrightarrow & Y & \longrightarrow & S \longrightarrow 0 \\
 & & \parallel & & \downarrow & & \downarrow \\
 0 & \longrightarrow & X & \longrightarrow & \text{corad } X & \longrightarrow & \text{cotop } X \longrightarrow 0.
 \end{array}$$

- (e) *For a simple A -module S , we have $\text{Ext}_A^1(S, X) \neq 0$ if and only if S is a direct summand of $\text{cotop } X$.*

Proof. Parts (a) and (b) are immediate and the first isomorphism of (c) is a consequence of (b). The second isomorphism of (c) is obtained by applying $\text{Hom}_R(-, R)$ to the short exact sequence $0 \rightarrow \text{rad } D_1 X \rightarrow D_1 X \rightarrow \text{top } D_1 X \rightarrow 0$. For (d), applying the functor $-\otimes_R K$ to the short exact sequence, we get $X \otimes_R K \cong Y \otimes_R K$. Therefore $X \subset Y \subset X \otimes_R K$. By the maximality of $\text{corad } X$, we have $Y \subset \text{corad } X$ and the result follows.

- (e) The implication “ \Leftarrow ” is immediate. Let us show “ \Rightarrow ”. Consider a nonsplit exact sequence $0 \rightarrow X \rightarrow Y \rightarrow S \rightarrow 0$. For any simple module S' , applying $\text{Hom}_A(S', -)$, we get an exact sequence $0 \rightarrow \text{Hom}_A(S', Y) \rightarrow \text{Hom}_A(S', S) \rightarrow \text{Ext}_A^1(S', X)$. It is easy to conclude in any case that $\text{Hom}_A(S', Y) = 0$, so $Y \in \text{CM } A$. Therefore, we can apply (d) so S is a summand of $\text{cotop } X$. \square

For logical reasons, we give the proof of [Theorem 2.1](#) after that of [Theorem 2.2](#).

5A. Proof of Theorem 2.2. As in Theorem 2.2, we consider an idempotent e of an R -order A such that $B := A/(e)$ has finite length over R . As $\text{mod } B \subset \text{f.l. } A$, D_0 restricts to a duality $\text{mod } B \xleftarrow{\sim} \text{mod } B^{\text{op}}$. We will separate the proof in five statements.

Proposition 5.3. *We have a torsion pair $(\text{add } Ae, \text{mod } B)$ in $\text{mod}_e A$.*

Proof. Since $B = A/(e)$, we have $\text{Hom}_A(\text{add } Ae, \text{mod } B) = 0$. For any $X \in \text{mod}_e A$, we have an exact sequence

$$Ae \otimes_{eAe} eX \xrightarrow{f} X \rightarrow B \otimes_A X \rightarrow 0 \tag{5-1}$$

in $\text{mod}_e A$. Since $eX \in \text{proj}(eAe)$, we have $Ae \otimes_{eAe} eX \in \text{add } Ae$. Multiplying the sequence (5-1) by e on the left, we see that $e \text{Ker } f = 0$ so $\text{Ker } f$ is in $\text{mod } B$. On the other hand, $\text{Ker } f$ is a submodule of $Ae \otimes_{eAe} eX \in \text{add } Ae$, so $\text{Ker } f \in \text{CM } A$. Consequently we have $\text{Ker } f = 0$. Now the sequence (5-1) shows the desired assertion. \square

Thanks to Proposition 5.3, we have two functors $T : \text{mod}_e A \rightarrow \text{add } Ae$ and $F : \text{mod}_e A \rightarrow \text{mod } B$ and a functorial exact sequence $0 \rightarrow TX \rightarrow X \rightarrow FX \rightarrow 0$ for $X \in \text{mod}_e A$. We prove the following easy statement:

Lemma 5.4. *If $X \in \text{CM}_e A$, then $FX \subset \text{Hom}_A(B, TX \otimes_R (K/R)) \subset TX \otimes_R (K/R)$ and $\text{soc } FX \subset \text{cotop } TX$.*

Proof. The inclusion $\text{Hom}_A(B, TX \otimes_R (K/R)) \subset TX \otimes_R (K/R)$ is obvious. Applying $-\otimes_R K$ on the short exact sequence $0 \rightarrow TX \rightarrow X \rightarrow FX \rightarrow 0$, we get that $TX \otimes_R K \cong X \otimes_R K$ so $X \subset TX \otimes_R K$ canonically. Thus we get a commutative diagram of short exact sequences

$$\begin{array}{ccccccc} 0 & \longrightarrow & TX & \longrightarrow & X & \longrightarrow & FX & \longrightarrow & 0 \\ & & \parallel & & \downarrow & & \downarrow & & \\ 0 & \longrightarrow & TX & \longrightarrow & TX \otimes_R K & \longrightarrow & TX \otimes_R (K/R) & \longrightarrow & 0 \end{array}$$

where the second line is obtained by applying $TX \otimes_R -$ to $0 \rightarrow R \rightarrow K \rightarrow K/R \rightarrow 0$. Thus $FX \subset TX \otimes_R (K/R)$. As $FX \in \text{mod } B$, we deduce that $FX \subset \text{Hom}_A(B, TX \otimes_R (K/R))$. The latter assertion follows from Lemma 5.2(a). \square

Proposition 5.5. *We have a torsion pair $(\text{mod } B, \text{CM}_e A)$ in $\text{mod}_e A$.*

Proof. Since any $X \in \text{mod } B$ has finite length, we have $\text{Hom}_A(\text{mod } B, \text{CM}_e A) = 0$. For any $X \in \text{mod}_e A$, there exists an exact sequence

$$0 \rightarrow T \rightarrow X \rightarrow F \rightarrow 0$$

in $\text{mod } A$ such that $\text{length}_R T < \infty$ and $F \in \text{CM } A$. Multiplying e from the left, we have an exact sequence

$$0 \rightarrow eT \rightarrow eX \rightarrow eF \rightarrow 0$$

with $\text{length}_R(eT) < \infty$ and $eX \in \text{proj}(eAe)$. Thus $eT = 0$ holds, and we have $T \in \text{mod } B$. On the other hand, $eF = eX \in \text{proj}(eAe)$ shows $F \in \text{CM}_e A$. Thus the assertion follows. \square

Now we can apply Theorems 4.1, 4.7 and 4.8 to

$$\mathcal{E} := \text{mod}_e A, \quad \mathcal{A} := \text{add } Ae, \quad \mathcal{B} := \text{mod } B \quad \text{and} \quad \mathcal{C} := \text{CM}_e A.$$

In this context, it is possible to compute explicitly the short exact sequence given in Theorem 4.7(a). For $P \in \text{add } Ae$, let

$$U^P := \text{Hom}_A(B, P \otimes_R (K/R)) \in \text{mod } B$$

and define $U := U^{Ae}$. For any $X \in \text{CM } A$, we define

$$B\text{-cotop } X := \text{Hom}_A(B, \text{cotop } X).$$

In other terms, $B\text{-cotop } X$ is the biggest B -module included in $\text{cotop } X$. We also define $B\text{-corad } X$ as the A -module satisfying

$$X \subset B\text{-corad } X \subset \text{corad } X \quad \text{and} \quad B\text{-cotop } X \cong (B\text{-corad } X)/X.$$

Lemma 5.6. *Let $P \in \text{add } Ae$. The following hold:*

- (a) *There is a short exact sequence $0 \rightarrow P \rightarrow C^P \rightarrow U^P \rightarrow 0$ in $\text{mod } A$ with $C^P \in \text{CM}_e A$ and $\text{Ext}_A^1(\text{mod } B, C^P) = 0$.*

Conversely, if $0 \rightarrow P \rightarrow C' \rightarrow U' \rightarrow 0$ is a short exact sequence with $C' \in \text{CM}_e A$, $U' \in \text{mod } B$ and $\text{Ext}_A^1(\text{mod } B, C') = 0$, then it is isomorphic to the above short exact sequence.

- (b) *We have an isomorphism $\text{soc } U^P \cong B\text{-cotop } P$ of B -modules.*

Proof. (a) Applying $P \otimes_R -$ to the short exact sequence $0 \rightarrow R \rightarrow K \rightarrow K/R \rightarrow 0$, we obtain the short exact sequence $0 \rightarrow P \rightarrow P \otimes_R K \rightarrow P \otimes_R (K/R) \rightarrow 0$ with $\text{Ext}_A^1(\text{f.l. } A, P \otimes_R K) = 0$ thanks to Lemma 5.1. Taking the pullback by the natural inclusion $U^P \subset P \otimes_R (K/R)$, we get the following commutative diagram of short exact sequences:

$$\begin{array}{ccccccc}
 & & & 0 & & 0 & \\
 & & & \downarrow & & \downarrow & \\
 0 & \longrightarrow & P & \longrightarrow & C^P & \longrightarrow & U^P & \longrightarrow & 0 \\
 & & \parallel & & \downarrow & & \downarrow & & \\
 0 & \longrightarrow & P & \longrightarrow & P \otimes_R K & \longrightarrow & P \otimes_R (K/R) & \longrightarrow & 0 \\
 & & & & \downarrow & & \downarrow & & \\
 & & & & Y & \xlongequal{\quad\quad\quad} & Y & & \\
 & & & & \downarrow & & \downarrow & & \\
 & & & & 0 & & 0 & &
 \end{array}$$

Since U^P is the maximal B -module included in $P \otimes_R (K/R)$, and $\text{mod } B$ is closed under extensions in $\text{mod } A$, we get $\text{Hom}_A(\text{mod } B, Y) = 0$. Then applying $\text{Hom}_A(\text{mod } B, -)$ to the second column, we find the exact sequence

$$0 = \text{Hom}_A(\text{mod } B, Y) \rightarrow \text{Ext}_A^1(\text{mod } B, C^P) \rightarrow \text{Ext}_A^1(\text{mod } B, P \otimes_R K) = 0.$$

Thus $\text{Ext}_A^1(\text{mod } B, C^P) = 0$ holds.

Now we prove the converse part. Applying $\text{Hom}_A(U', -)$ to the former sequence, we get a surjection $\text{Hom}_A(U', U^P) \twoheadrightarrow \text{Ext}_A^1(U', P)$ so there is a commutative diagram:

$$\begin{array}{ccccccccc} 0 & \longrightarrow & P & \longrightarrow & C' & \longrightarrow & U' & \longrightarrow & 0 \\ & & \parallel & & \downarrow f & & \downarrow g & & \\ 0 & \longrightarrow & P & \longrightarrow & C^P & \longrightarrow & U^P & \longrightarrow & 0 \end{array}$$

In the same way, there are $f' : C^P \rightarrow C'$ and $g' : U^P \rightarrow U'$ making a commutative diagram in the converse direction. Then $ff' - \text{id}_{C'}$ factors through U' , hence $ff' = \text{id}_{C'}$. Similarly, $f'f = \text{id}_{C^P}$. Hence, f and g are isomorphisms.

(b) By Lemma 5.2, $\text{cotop } P = \text{soc}(P \otimes_R (K/R))$. Applying $\text{Hom}_A(B, -)$ to both sides, we obtain $\text{Hom}_A(B, \text{cotop } P) = \text{Hom}_A(B, \text{soc}(P \otimes_R (K/R))) = \text{soc } U^P$. \square

We are ready to prove Theorem 2.2.

Proof of Theorem 2.2. (a) This follows from Propositions 5.3 and 5.5.

(b) This follows from Theorem 4.1(a) and (b) as $\text{Ext}_A^1(Y, Ae)$ is a finitely generated right (eAe) -module for any $Y \in \text{mod } B$.

(c) Our assumption (E1) implies $\text{CM}_e A \subset \mathcal{E}_1$. Thus the functor $F : (\text{CM}_e A)/[Ae] \rightarrow \text{mod } B$ is fully faithful by (a). It gives an equivalence $F : (\text{CM}_e A)/[Ae] \rightarrow \text{Sub } U$ by Theorem 4.7(b) and Lemma 5.6.

(d) This follows from (E2) and Theorem 4.7(c).

(e) Thanks to (E2), $\mathcal{E}_1 = \mathcal{E}_2$ so, using Theorem 4.1(d), (2-1) and (2-2) are equivalences of exact categories.

(f) It is classical that $\text{Sub } U$ has enough projective objects and enough injective objects (see [Demonet and Iyama \geq 2016] for a detailed argument). Using (e) and Remark 3.3(b), it immediately implies that $\text{CM}_e A$ has enough projective objects and enough injective objects. In the same way, as $\text{mod } B$ has enough injective objects and enough projective objects, \mathcal{E}_1 has the same property. Then $\text{mod}_e A$ has enough projective objects and enough injective objects by Theorem 4.8(a).

(g) For any $X \in \text{mod}_e A$, as $(\text{mod } B, \text{CM}_e A)$ is a torsion pair, there is a short exact sequence

$$0 \rightarrow Z \rightarrow X \rightarrow Y \rightarrow 0,$$

where $Z \in \text{mod } B$ and $Y \in \text{CM}_e A$. Applying $\text{Hom}_A(-, Ae)$ to this sequence, we find the exact sequence

$$0 = \text{Ext}_A^1(Y, Ae) \rightarrow \text{Ext}_A^1(X, Ae) \rightarrow \text{Ext}_A^1(Z, Ae) \rightarrow \text{Ext}_A^2(Y, Ae) = 0.$$

So $X \in \mathcal{E}_1$ if and only if $\text{Ext}_A^1(Z, Ae) = 0$. There is a short exact sequence

$$0 \rightarrow \text{soc } Z \rightarrow Z \rightarrow Z/\text{soc } Z \rightarrow 0,$$

and applying $\text{Hom}_A(-, Ae)$ to it, we find the exact sequence

$$0 \rightarrow \text{Ext}_A^1(Z/\text{soc } Z, Ae) \rightarrow \text{Ext}_A^1(Z, Ae) \rightarrow \text{Ext}_A^1(\text{soc } Z, Ae) \rightarrow 0,$$

so $\text{Ext}_A^1(Z, Ae) = 0$ if and only if $\text{Ext}_A^1(Z/\text{soc } Z, Ae) = \text{Ext}_A^1(\text{soc } Z, Ae) = 0$. By Lemma 5.2(e), for a simple B -module S , we have $\text{Ext}_A^1(S, Ae) = 0$ if and only if S is not a direct summand of B -cotop Ae if and only if $S \notin \text{Sub } U$ if and only if $\text{Hom}_A(P, S) = 0$, where P is the projective cover of $\text{soc } U$ in $\text{mod } B$. As Z is of finite length over R , an easy induction gives that $\text{Ext}_A^1(Z, Ae) = 0$ if and only if $\text{Hom}_A(P, Z) = 0$ if and only if $\text{Hom}_A(P, X) = 0$. \square

In the following lemma, we give sufficient conditions for (E1) and (E2):

Lemma 5.7. (a) *We have the implication (E2)⁺ \Rightarrow (E2).*

(b) *If $Ae = \text{Hom}_R(gA, R)$ for some idempotent $g \in A$, then (E1) and (E2)⁺ are satisfied.*

(c) *If (E1) is satisfied and $A \in \text{CM}_e A$, then (E2)⁺ is satisfied.*

Proof. (a) This directly follows from Proposition 3.4.

(b) In this case, $\text{Ext}_A^1(\text{CM } A, Ae) = 0$, so (E1) is clearly satisfied. If $X \in \text{mod } A$, it is immediate that its syzygy ΩX is in $\text{CM } A$ so $\text{Ext}_A^2(X, Ae) = \text{Ext}_A^1(\Omega X, Ae) = 0$. Therefore, (E2)⁺ holds.

(c) For $X \in \text{mod}_e A$, consider the projective cover $0 \rightarrow \Omega X \rightarrow P \rightarrow X \rightarrow 0$. As $eX \in \text{proj}(eAe)$, the short exact sequence $0 \rightarrow e\Omega X \rightarrow eP \rightarrow eX \rightarrow 0$ splits. Moreover, as $A \in \text{CM}_e A$, we have $eP \in \text{proj}(eAe)$ so $\Omega X \in \text{CM}_e A$. So, by (E1), $\text{Ext}_A^2(X, Ae) = \text{Ext}_A^1(\Omega X, Ae) = 0$ and (E2)⁺ holds. \square

We complete this subsection by giving basic relations between indecomposable injective objects of $\text{CM}_e A$ and their B -cotops. Let

$$\mathcal{O} := \{P \in \text{ind } Ae \mid B\text{-cotop } P \neq 0\}.$$

Notice that part (a) of Lemma 5.8 is a generalization of a well-known property of cotops in $\text{CM } A$.

Lemma 5.8. *Let $I \in \text{CM}_e A$ satisfying $\text{Ext}_A^1(\text{CM}_e A, I) = 0$. Then the following hold:*

(a) *If I is indecomposable, then B -cotop I is either 0 or simple.*

- (b) B -cotop $I = 0$ if and only if $\text{Ext}_A^1(\text{mod } B, I) = 0$.
- (c) For any short exact sequence $0 \rightarrow I \xrightarrow{i} X \xrightarrow{p} Y \rightarrow 0$, where i is a radical map, $X \in \text{CM}_e A$ and $Y \in \text{mod}_e A$, the map i factors as $I \subset B\text{-corad } I \hookrightarrow X$ and $\text{soc } Y \cong B\text{-cotop } I$.
- (d) If (E1) is satisfied, there are commuting bijections

$$\begin{array}{ccc}
 \mathcal{O} & \xrightarrow{\text{Hom}_A(B, - \otimes_R (K/R))} & \text{ind } U \\
 & \searrow^{B\text{-cotop}} & \downarrow \text{soc} \\
 & & \text{ind}(\text{soc } U)
 \end{array}$$

Proof. (a) Thanks to Lemma 5.2(c), $\text{cotop } I \cong D_0 \text{ top } D_1 I$, so we only have to show that the A^{op} -module $\text{Hom}_{A^{\text{op}}}(B, \text{top } D_1 I)$ is 0 or simple. Suppose that $\text{Hom}_{A^{\text{op}}}(B, \text{top } D_1 I)$ is not 0 or simple. We have two distinct maximal submodules $X_1, X_2 \subset D_1 I$ such that $S_1 := (D_1 I)/X_1$ and $S_2 := (D_1 I)/X_2$ are simple B^{op} -modules. By applying $\text{Hom}_R(-, R)$ on the short exact sequence $0 \rightarrow X_1 \rightarrow D_1 I \rightarrow S_1 \rightarrow 0$, we get the short exact sequence

$$0 \rightarrow I \xrightarrow{\iota_1} D_1 X_1 \rightarrow D_0 S_1 \rightarrow 0,$$

and therefore $e\iota_1 : eI \rightarrow e(D_1 X_1)$ is an isomorphism and $D_1 X_1 \in \text{CM}_e A$. In the same way, $e\iota_2 : eI \rightarrow e(D_1 X_2)$ is an isomorphism and $D_1 X_2 \in \text{CM}_e A$. We also get a nonsplit short exact sequence $0 \rightarrow Y \rightarrow X_1 \oplus X_2 \rightarrow D_1 I \rightarrow 0$. Applying D_1 to it, we get a short exact sequence $0 \rightarrow I \rightarrow D_1(X_1 \oplus X_2) \rightarrow D_1 Y \rightarrow 0$. Multiplying by e , we get the short exact sequence

$$0 \rightarrow eI \xrightarrow{[e\iota_1 \ e\iota_2]} e(D_1 X_1) \oplus e(D_1 X_2) \rightarrow e(D_1 Y) \rightarrow 0,$$

which splits as $e\iota_1$ and $e\iota_2$ are isomorphisms. Thus $0 \rightarrow I \rightarrow D_1(X_1 \oplus X_2) \rightarrow D_1 Y \rightarrow 0$ is a nonsplit short exact sequence in $\text{CM}_e A$. It is a contradiction as $\text{Ext}_A^1(\text{CM}_e A, I) = 0$.

(b) Thanks to Lemma 5.2(e), a simple B -module S is a direct summand of $B\text{-cotop } I$ if and only if $\text{Ext}_A^1(S, I) \neq 0$. Thus $B\text{-cotop } I = 0$ if and only if $\text{Ext}_A^1(S, I) = 0$ for any simple B -module S if and only if $\text{Ext}_A^1(\text{mod } B, I) = 0$.

(c) Thanks to Proposition 5.3, $\text{soc } Y \in \text{mod } B$. Consider the sequence $0 \rightarrow I \rightarrow p^{-1}(\text{soc } Y) \rightarrow \text{soc } Y \rightarrow 0$. Thanks to Lemma 5.2(d), we have $\text{soc } Y \hookrightarrow B\text{-cotop } I$.

We will prove, for each direct summand I' of I , that $B\text{-corad } I' (\subset X \otimes_R K)$ is included in X . Consider the short exact sequence $0 \rightarrow I' \rightarrow X \rightarrow Y' \rightarrow 0$ induced by the inclusion $I' \subset I$. As i is radical, this short exact sequence does not split and we get $Y' \notin \text{CM}_e A$ and $\text{soc } Y' \neq 0$. Pulling back $0 \rightarrow I' \rightarrow X \rightarrow Y' \rightarrow 0$ along $\text{soc } Y' \subset Y'$, we get a short exact sequence $0 \rightarrow I' \rightarrow X' \rightarrow \text{soc } Y' \rightarrow 0$ with $X' \subset X$ so $X' \in \text{CM}_e A$. Using (a) and Lemma 5.2(d), we obtain $\text{soc } Y' \cong B\text{-cotop } I'$ and

therefore $X' = B\text{-corad } I' \subset X$. Finally $B\text{-corad } I \subset X$ and therefore $B\text{-cotop } I \hookrightarrow Y$. As $B\text{-cotop } I$ is semisimple, $B\text{-cotop } I \hookrightarrow \text{soc } Y$. So $B\text{-cotop } I \cong \text{soc } Y$.

(d) First of all, thanks to (a) and [Lemma 5.6\(b\)](#), $B\text{-cotop}$ induces a surjection from \mathcal{O} to $\text{ind}(\text{soc } U)$. Let us prove that it is injective. Suppose that $P, P' \in \mathcal{O}$ satisfy $S := B\text{-cotop } P = B\text{-cotop } P'$ and consider the short exact sequences

$$0 \rightarrow P \xrightarrow{f} B\text{-corad } P \xrightarrow{g} S \rightarrow 0 \quad \text{and} \quad 0 \rightarrow P' \xrightarrow{f'} B\text{-corad } P' \xrightarrow{g'} S \rightarrow 0.$$

Multiplying them by e , we get $B\text{-corad } P, B\text{-corad } P' \in \text{CM}_e A$. So, applying $\text{Hom}_A(B\text{-corad } P, -)$ to the second short exact sequence, we get a morphism $u : B\text{-corad } P \rightarrow B\text{-corad } P'$ such that $g = ug'$. Symmetrically, we get a morphism $u' : B\text{-corad } P' \rightarrow B\text{-corad } P$ such that $g' = u'g$. So $g = uu'g$ and, as g is right minimal, uu' is an isomorphism. Similarly, $u'u$ is an isomorphism so $B\text{-corad } P \cong B\text{-corad } P'$ and $P \cong P'$. We proved that $B\text{-cotop}$ is injective on \mathcal{O} .

That $\text{Hom}_A(B, - \otimes_R (K/R)) : \mathcal{O} \rightarrow \text{add } U$ is well-defined is a direct consequence of the definition of U . The commutativity of the diagram is immediate by [Lemma 5.2\(a\)](#). As U is injective, $\text{soc} : \text{ind } U \rightarrow \text{ind}(\text{soc } U)$ is bijective. \square

The following proposition is used to categorify cluster algebras in [Section 6](#).

Proposition 5.9. *If (E1) is satisfied, then the following assertions hold:*

- (a) *If $X \in \text{CM}_e A$ does not have nonzero direct summands in $\text{add } Ae$, then $TX \in \text{add } \mathcal{O}$. Moreover, $B\text{-corad } TX \subset X$ and $B\text{-cotop } TX \cong \text{soc } FX$.*
- (b) *Let $0 \rightarrow X \rightarrow Y \rightarrow Z \rightarrow 0$ be a short exact sequence with $X, Z \in \text{CM}_e A$ without nonzero direct summands in $\text{add } Ae$. Then the maximal direct summand Y_1 of Y in $\text{add } Ae$ is the module satisfying $Y_1 \in \text{add } \mathcal{O}$ and $\text{soc } FX \oplus \text{soc } FZ \cong \text{soc } FY \oplus B\text{-cotop } Y_1$.*

Proof. (a) Since $TX \rightarrow X$ is radical, the result follows from [Lemma 5.8\(c\)](#).

(b) Decompose $Y = Y_0 \oplus Y_1$. Recall that $T = Ae \otimes_{eAe} e-$ is exact on $\text{mod}_e A$. As TX is projective, we get

$$TY_0 \oplus Y_1 = TY \cong TX \oplus TZ \in \text{add } \mathcal{O}$$

by (a). Again by (a), we get

$$\begin{aligned} \text{soc } FX \oplus \text{soc } FZ &\cong B\text{-cotop } TX \oplus B\text{-cotop } TZ \cong B\text{-cotop } TY_0 \oplus B\text{-cotop } Y_1 \\ &\cong \text{soc } FY_0 \oplus B\text{-cotop } Y_1 \cong \text{soc } FY \oplus B\text{-cotop } Y_1. \end{aligned} \quad \square$$

5B. Proof of Theorem 2.1. (a) Since $Ae \in \text{add Hom}_R(gA, R)$, the conditions (E1) and (E2) are satisfied by [Lemma 5.7](#) and $\text{cotop } Ae = \text{top } Ag$ by [Lemma 5.2\(c\)](#). By [Theorem 2.2](#), we have an equivalence of exact categories

$$B \otimes_A - : (\text{CM}_e A)/[Ae] \cong \text{Sub } U$$

and U is an injective B -module. Thanks to [Lemma 5.6\(b\)](#), we have $\text{soc } U \cong B\text{-cotop } Ae \cong \text{Hom}_A(B, \text{top } Ag)$. Thus $U \cong Q_g$.

(b) For $M \in \text{Sub } Q_g$, let us consider a projective cover of D_0M in $\text{mod } A^{\text{op}}$:

$$0 \rightarrow \Omega_A D_0M \rightarrow P \rightarrow D_0M \rightarrow 0.$$

We have $P \in \text{add } gA$. Applying $\text{Hom}_R(-, R)$, we get the short exact sequence

$$0 \rightarrow D_1P \rightarrow D_1\Omega_A D_0M \rightarrow M \rightarrow 0.$$

We have $D_1P \in \text{add } Ae$ so $D_1\Omega_A D_0M \in \text{CM}_e A$ and $F(D_1\Omega_A D_0M) \cong M$ thanks to this sequence.

(c) Let us assume first that Ae, Af and Ag are basic. In particular $Ae \cong D_1(gA)$, $Af \cong D_1(eA)$ as A -modules and $eAe \cong D_1(eAe)$ as left (eAe) -modules. We have $eAf \cong eD_1(eA) = D_1(eAe) \cong eAe$ as left (eAe) -modules. So $Af \in \text{CM}_e A$ and $T(Af) = Ae \otimes_{eAe} eAf \cong Ae$. Moreover, using the short exact sequence $0 \rightarrow T(Af) \rightarrow Af \rightarrow F(Af) \rightarrow 0$ and [Lemma 5.4](#), we get

$$\text{soc } Bf = \text{soc } F(Af) \subset B\text{-cotop } T(Af) \cong B\text{-cotop } Ae \cong \text{top } Bg,$$

so $Bf \subset D_0(gB)$. Dually, we get an inclusion $gB \subset D_0(Bf)$ by exchanging the role of f and g . By comparing lengths over R of gB and Bf , we deduce that $Bf \cong D_0(gB) = Q_g$.

If Ae, Af or Ag are not basic, we take basic parts e', f' and g' of e, f and g and we get $Bf' \cong Q_{g'}$. Thus $\text{add } Bf = \text{add } Bf' = \text{add } Q_{g'} = \text{add } Q_g$.

(d) Since $A \in \text{CM}_e A$, we have $B = FA \in \text{Sub } Q_g$. Thus $\text{Sub } Q_g = \text{Sub } B$ holds by (c).

(e) All assumptions in [Theorem 4.8](#) are satisfied. Moreover, since $A \in \mathcal{C}$, the projective objects in $\mathcal{E} = \text{mod}_e A$ and $\mathcal{C} = \text{CM}_e A$ are projective A -modules, and the equivalent conditions of [Theorem 4.8 \(a\)](#) are satisfied. Thus applying [Theorem 4.8\(d\)](#) (i) \Leftrightarrow (iii), B is Iwanaga–Gorenstein of dimension at most 1 if and only if $\text{CM}_e A$ is Frobenius. As A and D_1A are in $\text{CM}_e A$, we get that A is Gorenstein if and only if $\text{add } A = \text{add } D_1A$ if and only if $\text{CM}_e A$ is Frobenius, and the result follows.

(f) In this case, $(\text{CM}_e A)/[Ae] \cong \text{Sub } B$ is an equivalence of Frobenius categories. Thus, since $\underline{\text{CM}}_e A$ coincides with the stable category of $(\text{CM}_e A)/[Ae]$, we have a triangle equivalence $\underline{\text{CM}}_e A \cong \underline{\text{Sub}} B$. \square

5C. Proof of [Theorem 2.3](#). By construction, we have an exact sequence

$$0 \rightarrow P_W \rightarrow W \rightarrow B \rightarrow 0 \tag{5-2}$$

with $W = Ae \oplus \tilde{B} \in \text{CM } A$ and $P_W = Ae \oplus P \in \text{add } Ae$. Clearly we have $W \in \text{CM}_e^B A$ and $P_W = Ae \otimes_{eAe} eW$. We set $A' := \text{End}_A(W)$ and we identify e with the idempotent

of A' which is the projection on the summand Ae of W . Thus, we can identify eAe and $eA'e$. We shall prove (a) in [Proposition 5.11](#), (b) in [Proposition 5.15](#) and (d) in [Proposition 5.12](#). Then all hypotheses of [Theorem 2.2](#) are satisfied and the assertion (c) follows. Finally, (e) is an easy consequence of [Proposition 5.12](#).

Lemma 5.10. (a) *We have $We = Ae$ and $W(1 - e) = \widetilde{B}$ as A -modules.*

(b) *We have $WeA' = P_W$. Thus P_W and B have a structure of A'^{op} -modules such that (5-2) is an exact sequence of (A, A') -bimodules.*

(c) *We have $W/WeA' \cong B$ as (A, A') -bimodules.*

(d) *We have $eA' = eW$, and this is a projective (eAe) -module and a projective A'^{op} -module.*

(e) *We have $B \otimes_A W \cong B$ as (B, A') -bimodules.*

Proof. (a) This is clear from the definition.

(b) Since $We = Ae$, we have $WeA' = \sum_{f \in \text{End}_A(W)} f(Ae) = Ae \otimes_{eAe} eW = P_W$. The map $P_W \rightarrow W$ is clearly a morphism of (A, A') -bimodules.

(c) This is a clear consequence of (b).

(d) We have $eA' = \text{Hom}_A(Ae, W) = eW$. Clearly eA' is a projective A'^{op} -module. Moreover $eW = eP_W$ is a projective (eAe) -module since $P_W \in \text{add } Ae$.

(e) Applying $B \otimes_A -$ to the short exact sequence (5-2), we get the exact sequence of (B, A') -bimodules

$$B \otimes_A P_W \rightarrow B \otimes_A W \rightarrow B \otimes_A B \rightarrow 0.$$

Since $B \otimes_A P_W \in \text{add}(B \otimes_A Ae) = \text{add}(Be) = \{0\}$ and $B \otimes_A B \cong B$, we get the result. □

Proposition 5.11. *We have an isomorphism $A'/(e) \cong B$ of R -algebras and an isomorphism $W \otimes_{A'} B \cong B$ of (A, B) -bimodules.*

Proof. Applying $\text{Hom}_A(W, -)$ to (5-2), we have an exact sequence

$$0 \rightarrow \text{Hom}_A(W, P_W) \rightarrow A' \rightarrow \text{Hom}_A(W, B) \rightarrow \text{Ext}_A^1(W, P_W),$$

where $\text{Ext}_A^1(W, P_W) = 0$ by $P_W \in \text{add } Ae$, $W \in \text{CM}_e^B A$ and our assumption $\text{Ext}_A^1(\text{CM}_e^B A, Ae) = 0$. Since $\text{Hom}_A(Ae, B) = 0$, applying $\text{Hom}_A(-, B)$ to (5-2), we have $\text{Hom}_A(W, B) = \text{End}_A(B) = B$ and $(e) = \text{Hom}_A(W, P_W)$. Thus $A'/(e) = A'/\text{Hom}_A(W, P_W) = \text{Hom}_A(W, B) = B$.

We have $W \otimes_{A'} B = W/WeA' = B$ by [Lemma 5.10\(c\)](#). □

In particular, we can regard $\text{mod } B$ as full subcategory of both $\text{mod } A'$ and $\text{mod } A$. Now we consider the adjoint pair (G, H) given by

$$H := \text{Hom}_A(W, -) : \text{mod } A \rightarrow \text{mod } A' \quad \text{and} \quad G := W \otimes_{A'} - : \text{mod } A' \rightarrow \text{mod } A.$$

The main result about these functors is:

Proposition 5.12. *The class of short exact sequences of $\text{mod } A$ with three terms in $\text{mod}_e^B A$ gives the structure of an exact category on $\text{mod}_e^B A$. The same holds for $\text{CM}_e^B A$. For these structures, the adjoint pair (G, H) gives quasi-inverse equivalences of exact categories between $\text{mod}_e^B A$ and $\text{mod}_e A'$, which restrict to quasi-inverse equivalences of exact categories between $\text{CM}_e^B A$ and $\text{CM}_e A'$.*

The first step of the proof consists of the following lemma.

Lemma 5.13. (a) *H and G give quasi-inverse equivalences between $\text{add } Ae$ and $\text{add } A'e$.*

(b) *We have commutative diagrams*



Proof. (a) This is clear: $H(Ae) = \text{Hom}_A(W, Ae) = A'e$ and $G(A'e) \cong We = Ae$ by Lemma 5.10(a).

(b) Fix $X \in \text{mod } B$. Applying $\text{Hom}_A(-, X)$ to (5-2), we have an exact sequence

$$0 \rightarrow \text{Hom}_A(B, X) \rightarrow HX \rightarrow \text{Hom}_A(P_W, X),$$

where $\text{Hom}_A(P_W, X) = 0$ by $P_W \in \text{add } Ae$ and $X \in \text{mod } B$. Thus we have

$$HX \cong \text{Hom}_A(B, X) \cong X.$$

On the other hand, we have

$$G(X) = W \otimes_{A'} X = W \otimes_{A'} (B \otimes_{A'} X) \stackrel{\text{Proposition 5.11}}{=} B \otimes_{A'} X = X. \quad \square$$

Lemma 5.14. (a) *We have $\text{Tor}_1^{A'}(Y, X) = \text{Tor}_1^B(Y \otimes_{A'} B, X)$ for any $X \in \text{mod } B$ and $Y \in \text{CM } A'^{\text{op}}$.*

(b) *We have $\text{Tor}_1^{A'}(W, X) = 0$ for any $X \in \text{mod}_e A'$.*

Proof. For $Y \in \text{CM } A'^{\text{op}}$, take an exact sequence

$$0 \rightarrow \Omega Y \xrightarrow{i} P \rightarrow Y \rightarrow 0 \tag{5-3}$$

of A'^{op} -modules with $P \in \text{proj } A'^{\text{op}}$. We will show that

$$0 \rightarrow \Omega Y \otimes_{A'} B \xrightarrow{i \otimes 1_B} P \otimes_{A'} B \rightarrow Y \otimes_{A'} B \rightarrow 0 \tag{5-4}$$

is exact. Consider the exact sequence

$$A'e \otimes_{eA'e} eA' \xrightarrow{j} A' \rightarrow B \rightarrow 0$$

of (A', A') -bimodules. Applying $Y \otimes_{A'} -$, we have an exact sequence

$$0 \rightarrow K \rightarrow Ye \otimes_{eA'e} eA' \xrightarrow{1_Y \otimes j} Y \rightarrow Y \otimes_{A'} B \rightarrow 0.$$

Since $(1_Y \otimes j)e : (Ye \otimes_{eA'e} eA')e \rightarrow Ye$ is an isomorphism, we have $Ke = 0$. Thus K is a B^{op} -module. Since $eA' \in \text{proj}(eA'e)$ by Lemma 5.10(d), we get $Ye \otimes_{eA'e} eA' \in \text{CM } A'^{\text{op}}$. Therefore $K = 0$.

Applying the same argument to $P \in \text{CM } A'^{\text{op}}$ and $\Omega Y \in \text{CM } A'^{\text{op}}$, we have the following commutative diagram of exact sequences:

$$\begin{array}{ccccccc}
 & & & & 0 & & \\
 & & & & \downarrow & & \\
 0 & \longrightarrow & \Omega Ye \otimes_{eA'e} eA & \longrightarrow & \Omega Y & \longrightarrow & \Omega Y \otimes_{A'} B \longrightarrow 0 \\
 & & \downarrow & & \downarrow & & \downarrow i \otimes 1_B \\
 0 & \longrightarrow & Pe \otimes_{eA'e} eA & \longrightarrow & P & \longrightarrow & P \otimes_{A'} B \longrightarrow 0 \\
 & & \downarrow & & \downarrow & & \downarrow \\
 0 & \longrightarrow & Ye \otimes_{eA'e} eA & \longrightarrow & Y & \longrightarrow & Y \otimes_{A'} B \longrightarrow 0 \\
 & & \downarrow & & \downarrow & & \downarrow \\
 & & 0 & & 0 & & 0
 \end{array}$$

By the snake lemma, $i \otimes 1_B$ is injective. Thus (5-4) is exact.

(a) For $X \in \text{mod } B$, applying $-\otimes_{A'} X$ to (5-3) and $-\otimes_B X$ to (5-4) and comparing them, we have a commutative diagram of exact sequences:

$$\begin{array}{ccccccc}
 0 & \longrightarrow & \text{Tor}_1^{A'}(Y, X) & \longrightarrow & \Omega Y \otimes_{A'} X & \longrightarrow & P \otimes_{A'} X \\
 & & & & \parallel & & \parallel \\
 0 & \longrightarrow & \text{Tor}_1^B(Y \otimes_{A'} B, X) & \longrightarrow & (\Omega Y \otimes_{A'} B) \otimes_B X & \longrightarrow & (P \otimes_{A'} B) \otimes_B X
 \end{array}$$

Thus the assertion follows.

(b) First, we assume $X \in \text{mod } B$. Since $W \in \text{CM } A'^{\text{op}}$, by (a) and Proposition 5.11, we have

$$\text{Tor}_1^{A'}(W, X) \cong \text{Tor}_1^B(W \otimes_{A'} B, X) \cong \text{Tor}_1^B(B, X) = 0.$$

Now we assume $X \in \text{mod}_e A'$. Then there exists an exact sequence $0 \rightarrow P \rightarrow X \rightarrow Y \rightarrow 0$ with $P \in \text{add } A'e$ and $Y \in \text{mod } B$. Applying $W \otimes_{A'} -$, we have an exact sequence

$$0 = \text{Tor}_1^{A'}(W, P) \rightarrow \text{Tor}_1^{A'}(W, X) \rightarrow \text{Tor}_1^{A'}(W, Y) = 0.$$

Thus the assertion follows. □

Proof of Proposition 5.12. (i) First we show $H(\text{mod}_e A) \subset \text{mod}_e A'$.

For $X \in \text{mod}_e A$, we get, using Lemma 5.10(a),

$$eH(X) = \text{Hom}_A(We, X) = \text{Hom}_A(Ae, X) = eX \in \text{proj}(eAe) = \text{proj}(eA'e).$$

(ii) Next we show $G(\text{mod}_e A') \in \text{mod}_e^B A$.

For $X \in \text{mod}_e A'$, take an exact sequence

$$0 \rightarrow P \rightarrow X \rightarrow Y \rightarrow 0 \tag{5-5}$$

with $P \in \text{add } A'e$ and $Y \in \text{mod } B$. Applying G , we have a short exact sequence

$$0 \rightarrow GP \rightarrow GX \rightarrow GY \rightarrow 0 \tag{5-6}$$

by Lemma 5.14(b). Since $GP \in \text{add } Ae$ and $GY = Y \in \text{mod } B$ thanks to Lemma 5.13, we have $GX \in \text{mod}_e^B A'$.

(iii) We now show $HG \cong \text{id}_{\text{mod}_e A'}$ and $GH \cong \text{id}_{\text{mod}_e^B A}$.

Applying H to (5-6) and comparing with (5-5), we have a commutative diagram of exact sequences

$$\begin{array}{ccccccccc} 0 & \longrightarrow & P & \longrightarrow & X & \longrightarrow & Y & \longrightarrow & 0 \\ & & \downarrow & & \downarrow & & \downarrow & & \\ 0 & \longrightarrow & HGP & \longrightarrow & HGX & \longrightarrow & HGY & & \end{array}$$

where vertical arrows are of the form $x \mapsto (w \mapsto w \otimes x)$. Since the left and the right vertical maps are isomorphisms, so is the middle one.

By a similar argument, one can show $GH \cong \text{id}_{\text{mod}_e^B A}$.

(iv) Next we show that $H : \text{mod}_e^B A \rightarrow \text{mod}_e A'$ and $G : \text{mod}_e A' \rightarrow \text{mod}_e^B A$ preserve short exact sequences. In particular, $\text{mod}_e^B A$ has the desired exact structure.

The functor G is exact thanks to Lemma 5.14(b). Consider a short exact sequence $0 \rightarrow X \rightarrow Y \rightarrow Z \rightarrow 0$ in $\text{mod } A$ with three terms in $\text{mod}_e^B A$. We get an exact sequence $0 \rightarrow HX \rightarrow HY \rightarrow HZ \rightarrow C \rightarrow 0$ with $C \in \text{mod } A'$. As G is right exact and by (iii), we deduce $W \otimes_{A'} C = GC = 0$, so $eC = eW \otimes_{A'} C = 0$ by Lemma 5.10(d), so $C \in \text{mod } B$. Hence by Lemma 5.13(b), $C = 0$ so $0 \rightarrow HX \rightarrow HY \rightarrow HZ \rightarrow 0$ is exact in $\text{mod}_e A'$.

(v) We now show that the equivalences restrict to $\text{CM}_e^B A \cong \text{CM}_e A'$.

Clearly $H(\text{CM}_e^B A) \subset \text{CM}_e A'$ holds. It is enough to show that, if $X \in \text{mod}_e^B A$ satisfies $HX \in \text{CM}_e A'$, then $X \in \text{CM}_e A$. Let Y be a finite-length submodule of X . Then the inclusion $Y \subset X$ gives an injection $HY \subset HX$. Since HY has finite length and $HX \in \text{CM}_e A'$, we have $HY = 0$.

Let $0 \rightarrow P \xrightarrow{i} X \rightarrow Z \rightarrow 0$ be an exact sequence with $P \in \text{add } Ae$ and $Z \in \text{mod } B$. Since $Y \cap P = 0$, we have that Y is a submodule of Z . In particular $Y \in \text{mod } B$. Since $HY = 0$, we have $Y = 0$ by (iii). Thus $X \in \text{CM}_e A$. □

Proposition 5.15. *We have (E1), that is, $\text{Ext}_{A'}^1(\text{CM}_e A', A'e) = 0$, and (E2)⁺, that is, $\text{Ext}_{A'}^2(\text{mod}_e A', A'e) = 0$.*

Proof. (E1): Let $0 \rightarrow A'e \rightarrow X \rightarrow Y \rightarrow 0$ be an exact sequence with $Y \in \text{CM}_e A'$. Applying G and using Lemma 5.14(b), we have an exact sequence $0 \rightarrow G(A'e) \rightarrow$

$GX \rightarrow GY \rightarrow 0$. It splits since $\text{Ext}_A^1(GY, Ae) = 0$ by our assumption. Since $G : \text{CM}_e A' \rightarrow \text{CM}_e^B A$ is an equivalence, the original sequence splits. Thus the assertion follows.

(E2)⁺: Since we have $A' \in \text{CM}_e A'$ by Lemma 5.10(d), syzygies of modules in $\text{mod}_e A'$ belong to $\text{CM}_e A'$. Thus the assertion follows from (E1). □

We finish this subsection by proving Lemma 2.4.

Proof of Lemma 2.4. As $Ae \cong D_1(gA)$ is injective in $\text{CM } A$ and $\text{CM}_e^B A \subset \text{CM } A$, we get (C3).

To prove the second part of the statement, let us prove that if (C1) holds, then for a finite-length A -module M , we have $M \in \text{Sub}(Ae \otimes_R (K/R))$ if and only if $(1 - g) \text{soc } M = 0$. As Ae is injective in $\text{CM } A$ and syzygies of all modules are Cohen–Macaulay, we have $\text{Ext}_A^2(\text{mod } A, Ae) = 0$. By Lemma 5.1, we have $\text{Ext}_A^1(\text{f.l. } A, Ae \otimes_R K) = 0$. So applying $\text{Hom}_A(\text{f.l. } A, -)$ to the short exact sequence

$$0 \rightarrow Ae \rightarrow Ae \otimes_R K \rightarrow Ae \otimes_R (K/R) \rightarrow 0,$$

we get $\text{Ext}_A^1(\text{f.l. } A, Ae \otimes_R (K/R)) = 0$. Moreover, by Lemma 5.2(a), we get that $\text{soc}(Ae \otimes_R (K/R))$ is the semisimple module corresponding to g .

If $M \in \text{Sub}(Ae \otimes_R (K/R))$ then $\text{soc } M \in \text{add } \text{soc}(Ae \otimes_R (K/R))$ follows immediately, and thus the first implication is satisfied. Conversely, if $(1 - g) \text{soc } M = 0$, then there exists an injection $\text{soc } M \hookrightarrow (Ae \otimes_R (K/R))^{\oplus \ell}$. Then, by applying $\text{Hom}_A(-, (Ae \otimes_R (K/R))^{\oplus \ell})$ to the short exact sequence

$$0 \rightarrow \text{soc } M \rightarrow M \rightarrow M/\text{soc } M \rightarrow 0$$

and using $\text{Ext}_A^1(M/\text{soc } M, Ae \otimes_R (K/R)) = 0$, there is an injection $M \hookrightarrow (Ae \otimes_R (K/R))^{\oplus \ell}$, and so we have proved the converse implication. □

6. Cluster algebra structure on coordinate rings of partial flag varieties

The aim of this section is to apply results in previous sections to categorify the cluster algebra structure of the multihomogeneous coordinate rings $\mathbb{C}[\mathcal{F}]$ of the partial flag variety $\mathcal{F} = \mathcal{F}(\Delta, J)$ corresponding to a Dynkin diagram Δ and a set J of vertices of Δ by using the category of Cohen–Macaulay modules. To be more precise, recall that Geiss, Leclerc and Schröer [2008] introduced a cluster algebra $\tilde{\mathcal{A}} \subset \mathbb{C}[\mathcal{F}]$. They proved that $\tilde{\mathcal{A}} = \mathbb{C}[\mathcal{F}]$ in type A_n . In general, they conjecture that $\tilde{\mathcal{A}}[\Sigma_J^{-1}] = \mathbb{C}[\mathcal{F}][\Sigma_J^{-1}]$, where Σ_J is the set of principal generalized minors corresponding to nonminuscule weights (see Definition 6.3 of principal generalized minors), and they prove the conjecture in type D_4 .

The main result of this section (Theorem 6.12) consists of completing Geiss, Leclerc and Schröer’s partial categorification of $\tilde{\mathcal{A}}$. Their categorification, given in Theorem 6.6, uses the preprojective algebra $\Pi = \Pi(\Delta)$ over \mathbb{C} and the full

subcategory $\text{Sub } Q_J$ of $\text{mod } \Pi$, where Q_J is the direct sum of indecomposable injective Π -modules corresponding to vertices in J . Recall that a Frobenius category \mathcal{E} is said to be *stably 2-Calabi–Yau* if there is a bifunctorial isomorphism $\text{Ext}_{\mathcal{E}}^1(X, Y) \cong D \text{Ext}_{\mathcal{E}}^1(Y, X)$ and that $\text{Sub } Q_J$ is stably 2-Calabi–Yau. Moreover, an object X in \mathcal{E} is called *rigid* if $\text{Ext}_{\mathcal{E}}^1(X, X) = 0$ and it is called *cluster tilting* if $\text{add } X = \{Y \in \mathcal{E} \mid \text{Ext}_{\mathcal{E}}^1(Y, X) = 0\}$.

6A. The categorification of Geiss, Leclerc and Schröer. We recall briefly the results of [Geiss et al. 2008] concerning the categorification of cluster algebra structures on multihomogeneous coordinate rings of partial flag varieties. We start by fixing a simple simply connected complex algebraic group G with Dynkin diagram Δ . We fix a maximal torus $H \subset G$ and two opposite Borel subgroups $B, B^- \subset G$ satisfying $B \cap B^- = H$ (for more details about Lie theoretical background, see [Borel 1991; Lakshmibai and Gonciulea 2001]). For a vertex i of Δ , we fix

$$x_i(t) := \exp(te_i) \quad \text{and} \quad y_i(t) := \exp(tf_i),$$

the one-parameter subgroups of B and B^- corresponding to the Chevalley generators e_i and f_i of the Lie algebra of G . Following notations of [Geiss et al. 2008], we define K to be the complement of J . The *parabolic subgroup* B_K of G is the subgroup generated by B and y_i for $i \in K$, and the *opposite parabolic subgroup* $B_{\bar{K}}$ of G is the subgroup generated by B^- and x_i for $i \in K$. The partial flag variety \mathcal{F} can be realized as $\mathcal{F} = B_{\bar{K}} \backslash G$. Let N_K be the unipotent radical of B_K , that is, the subgroup of unipotent elements of the maximal solvable normal subgroup of B_K . Then, it is a classical result that $N_K \subset G$ induces an embedding $N_K \subset \mathcal{F}$ as a dense affine open subset.

Example 6.1. If $\Delta = A_4$ and $J = \{1, 3\}$, we have $K = \{2, 4\}$, $G = \text{SL}_5(\mathbb{C})$ and

$$B_{\bar{K}} = \begin{bmatrix} * & 0 & 0 & 0 & 0 \\ * & * & * & 0 & 0 \\ * & * & * & 0 & 0 \\ * & * & * & * & * \\ * & * & * & * & * \end{bmatrix} \subset G \quad \text{and} \quad N_K = \begin{bmatrix} 1 & * & * & * & * \\ 0 & 1 & 0 & * & * \\ 0 & 0 & 1 & * & * \\ 0 & 0 & 0 & 1 & 0 \\ 0 & 0 & 0 & 0 & 1 \end{bmatrix},$$

and it is immediate that $B_{\bar{K}} \backslash G$ parametrizes naturally flags of \mathbb{C}^5 of type $(1, 3)$.

Let $\mathbf{i} = (i_1, i_2, \dots, i_\ell)$ be a sequence of vertices of Δ , let $\mathbf{k} = (k_1, k_2, \dots, k_\ell)$ be a sequence of nonnegative integers and let $\mathbf{t} = (t_1, t_2, \dots, t_\ell)$ be a sequence of variables. We define

- $\mathbf{i}^{\mathbf{k}}$, the sequence of indices obtained from \mathbf{i} by repeating k_j times i_j ;
- $\mathbf{t}^{\mathbf{k}} := t_1^{k_1} t_2^{k_2} \cdots t_\ell^{k_\ell}$;
- $\mathbf{k}! := k_1! k_2! \cdots k_\ell!$;
- $x_{\mathbf{i}}(\mathbf{t}) := x_{i_1}(t_1) x_{i_2}(t_2) \cdots x_{i_\ell}(t_\ell)$.

For a vertex i of Δ , we denote by S_i the simple Π -module corresponding to i . Then, for $M \in \text{mod } \Pi$, we denote by $\Phi_{M,i}$ the variety of composition series of M of type i , that is,

$$\Phi_{M,i} := \{0 = M_0 \subset M_1 \subset \dots \subset M_\ell = M \mid \forall j, M_j/M_{j-1} \cong S_{i_j}\},$$

realized within the appropriate product of Grassmannians. Finally χ is the Euler characteristic.

Using Lusztig’s semicanonical basis [2000], Geiss, Leclerc and Schröer [Geiss et al. 2005] define functions in the coordinate ring $\mathbb{C}[N] = \mathbb{C}[N_\emptyset]$ by the following result:

Theorem 6.2 ([Lusztig 2000; Geiss et al. 2005]). *Let $M \in \text{mod } \Pi$. There exists a unique function φ_M in $\mathbb{C}[N]$ satisfying*

$$\varphi_M(x_i(t)) = \sum_{k \in \mathbb{N}^\ell} \chi(\Phi_{M,i^k}) \frac{t^k}{k!}$$

for any reduced word i of an element of the Weyl group of type Δ .

In [Geiss et al. 2005], they also prove that

- $\varphi_{Y \oplus Z} = \varphi_Y \varphi_Z$ for any $Y, Z \in \text{mod } \Pi$;
- if Y and Z are indecomposable such that $\dim \text{Ext}_\Pi^1(Y, Z) = 1$ and

$$0 \rightarrow Y \rightarrow U \rightarrow Z \rightarrow 0 \quad \text{and} \quad 0 \rightarrow Z \rightarrow U' \rightarrow Y \rightarrow 0$$

are two nonsplit short exact sequences, then $\varphi_Y \varphi_Z = \varphi_U + \varphi_{U'}$.

In other terms, φ is a so-called *cluster character*.

In [Geiss et al. 2008], the authors prove that $\text{Sub } Q_J$ categorifies via φ and the canonical projection $\mathbb{C}[N] \rightarrow \mathbb{C}[N_K]$ a cluster algebra $\mathcal{A} \subset \mathbb{C}[N_K]$. They prove in type A_n and D_4 that $\mathcal{A} = \mathbb{C}[N_K]$ and they conjecture it to be true in any case.

Let us introduced generalized principal minors (see [Fomin and Zelevinsky 1999]):

Definition 6.3. For a vertex i of Δ , the corresponding *principal generalized minor* is defined on G as the unique function Δ_i satisfying

$$\Delta_i(x^- x_0 x^+) = \Delta_i(x_0)$$

for $x^- \in B^-$, $x_0 \in H$ and $x^+ \in B$, and $\Delta_i|_H : H \rightarrow \mathbb{C}^*$ is the multiplicative character corresponding to the fundamental weight indexed by i .

It is known that $\mathcal{F} = B_K^- \backslash G$ is embedded in a product of projective spaces indexed by J (in type A_n , a product of usual Grassmannians). Thus, we can define the *multihomogeneous coordinate ring* $\mathbb{C}[\mathcal{F}]$, graded by \mathbb{N}^J . Each of the Δ_j is homogeneous of degree $(0, \dots, 0, 1, 0, \dots, 0)$, where 1 is at position j and N_K is

the open dense affine subset of \mathcal{F} defined by $N_K = \{x \in \mathcal{F} \mid \forall j \in J, \Delta_j(x) \neq 0\}$, so there is a dehomogenization map $\mathbb{C}[\mathcal{F}] \rightarrow \mathbb{C}[N_K]$ defined by mapping Δ_j to 1. For any $f \in \mathbb{C}[N_K]$, there is a unique homogeneous $\tilde{f} \in \mathbb{C}[\mathcal{F}]$ such that $\pi(\tilde{f}) = f$ and the multidegree of \tilde{f} is minimal for the order induced by fundamental weights [Geiss et al. 2008, Lemma 2.4].

Example 6.4. We continue Example 6.1. In this case, Δ_1 corresponds to the upper-left coefficient and Δ_3 corresponds to the determinant of the upper-left (3×3) -submatrix. Then $B_{\bar{K}} \setminus G$ is a closed subset of $\text{Gr}_1(\mathbb{C}^5) \times \text{Gr}_3(\mathbb{C}^5)$, by mapping $M \in B_{\bar{K}}$ to the subspaces generated by the first row on the one hand and the first three rows on the second hand. So, as usual, thanks to Plücker coordinates, we have

$$\mathcal{F} \subset \text{Gr}_1(\mathbb{C}^5) \times \text{Gr}_3(\mathbb{C}^5) \subset \mathbb{P}(\mathbb{C}^{\binom{5}{1}}) \times \mathbb{P}(\mathbb{C}^{\binom{5}{3}}).$$

Then, we have two affine subspaces $N_{\{1\}^c}$ of $\text{Gr}_1(\mathbb{C}^5)$ and $N_{\{3\}^c}$ of $\text{Gr}_3(\mathbb{C}^5)$ defined by the nonvanishing of the leftmost determinants, which are Plücker coordinates and correspond to Δ_1 and Δ_3 as functions over G . Moreover, $N_K = (N_{\{1\}^c} \times N_{\{3\}^c}) \cap \mathcal{F}$.

In order to extend the cluster algebra $\mathcal{A} \subset \mathbb{C}[N_K]$ to a cluster algebra $\tilde{\mathcal{A}} \subset \mathbb{C}[\mathcal{F}]$ by adding coefficients Δ_j corresponding to the multihomogenization, Geiss, Leclerc and Schröer prove the following theorem.

Theorem 6.5 [Geiss et al. 2008, 10.1]. *If $Y, Z \in \text{Sub } Q_J$, then $\tilde{\varphi}_{Y \oplus Z} = \tilde{\varphi}_Y \tilde{\varphi}_Z$. If $Y, Z \in \text{Sub } Q_J$ satisfy $\dim \text{Ext}_{\Pi}^1(Y, Z) = 1$, and*

$$0 \rightarrow Y \rightarrow U \rightarrow Z \rightarrow 0 \quad \text{and} \quad 0 \rightarrow Z \rightarrow U' \rightarrow Y \rightarrow 0$$

are nonsplit short exact sequences, then

$$\tilde{\varphi}_Y \tilde{\varphi}_Z = \tilde{\varphi}_U \prod_{j \in J} \Delta_j^{\alpha_j} + \tilde{\varphi}_{U'} \prod_{j \in J} \Delta_j^{\beta_j},$$

where

$$\begin{aligned} \alpha_j &= \max(0, \dim \text{Hom}_{\Pi}(S_j, U') - \dim \text{Hom}_{\Pi}(S_j, U)), \\ \beta_j &= \max(0, \dim \text{Hom}_{\Pi}(S_j, U) - \dim \text{Hom}_{\Pi}(S_j, U')). \end{aligned}$$

To construct $\tilde{\mathcal{A}}$ using Theorem 6.5, Geiss, Leclerc and Schröer constructed an explicit cluster tilting object in $\text{Sub } Q_J$ that they call *initial*. A cluster tilting object in $\text{Sub } Q_J$ is called *reachable* if it is obtained from the initial one by successive mutations. An indecomposable rigid object is called *reachable* if it is a direct summand of a reachable cluster tilting object. Their result can be stated as follows.

Theorem 6.6 [Geiss et al. 2008, Theorem 10.2]. (a) *There is a cluster algebra $\tilde{\mathcal{A}} \subset \mathbb{C}[\mathcal{F}]$ such that*

- *coefficients of $\tilde{\mathcal{A}}$ are \tilde{c} for each coefficient c of \mathcal{A} and Δ_j for each $j \in J$;*

- clusters of $\tilde{\mathcal{A}}$ are

$$\{\tilde{x}_1, \tilde{x}_2, \dots, \tilde{x}_\ell\} \sqcup \{\Delta_j \mid j \in J\}$$

for each cluster $\{x_1, x_2, \dots, x_\ell\}$ of \mathcal{A} .

(b) There is a bijection $X \mapsto \tilde{\varphi}_X$ between

- isomorphism classes of reachable indecomposable rigid objects of $\text{Sub } Q_J$;
- cluster variables and coefficients of $\tilde{\mathcal{A}}$ except Δ_j for $j \in J$.

(c) There is a bijection $\bigoplus_{k=1}^\ell T_k \mapsto \{\tilde{\varphi}_{T_1}, \tilde{\varphi}_{T_2}, \dots, \tilde{\varphi}_{T_\ell}\} \sqcup \{\Delta_j \mid j \in J\}$ between

- isomorphism classes of reachable basic cluster tilting objects of $\text{Sub } Q_J$;
- clusters of $\tilde{\mathcal{A}}$.

Moreover, it commutes with mutation of cluster tilting objects and mutation of clusters.

6B. Categorification of the cluster algebra structure of $\mathbb{C}[\mathcal{F}]$ using $\text{CM}_e A$. We

keep the setting of the beginning of this section, and we fix $R := \mathbb{C}[[t]]$. Our aim is to categorify $\mathbb{C}[\mathcal{F}(\Delta, J)]$ by a category $\text{CM}_e A$, where A is an R -order and $e \in A$ is an idempotent. We denote by $g = g_J$ the idempotent of Π corresponding to the set J . We also define $I_J := \text{Hom}_\Pi(\Pi/(g), \Pi)$, which is the biggest ideal of Π satisfying $gI_J = 0$. We observe that

- injective modules corresponding to $j \in J$ in $\text{mod } \Pi$ and $\text{mod } \Pi/I_J$ coincide;
- $\Pi/I_J \in \text{Sub } Q_J \subset \text{mod } \Pi/I_J \subset \text{mod } \Pi$.

We define pairs (A, e) permitting the categorification.

Definition 6.7. A pair (A, e) , where A is an R -order and $e \in A$ is an idempotent models (Δ, J) if

- $B := A/(e) \cong \Pi(\Delta)/I_J$ as \mathbb{C} -algebras;
- $\text{Ext}_A^1(\text{CM}_e A, Ae) = 0$, that is, (E1) holds, and $\text{Ext}_{\text{mod}_e A}^2(\text{mod}_e A, Ae) = 0$, that is, (E2) holds;
- B -cotop induces a bijection from $\text{ind } Ae$ to $\text{ind}(\text{soc } Q_J)$.

Using the last condition of Definition 6.7, if (A, e) models (Δ, J) , we can decompose e as sum of primitive orthogonal idempotents $e = \sum_{j \in J} e_j$ in such a way that for every $j \in J$,

$$B\text{-cotop } Ae_j \cong S_j, \tag{6-1}$$

where, as before, S_j is $\text{soc } Q_j$ (not $\text{top } Ae_j$).

In this context, we have the following equivalence of categories:

Lemma 6.8. If (A, e) models (Δ, J) , then $B \otimes_A -$ restricts to an exact bijective functor $F : \text{CM}_e A \rightarrow \text{Sub } Q_J$, which induces an equivalence of exact categories $(\text{CM}_e A)/[Ae] \rightarrow \text{Sub } Q_J$.

Proof. Thanks to [Theorem 2.2\(d\)](#) and [\(e\)](#), $F := B \otimes_A - : \text{CM}_e A \rightarrow \text{Sub } U$ induces an equivalence of exact categories $(\text{CM}_e A)/[Ae] \rightarrow \text{Sub } U$ for some injective B -module U , so F is exact bijective. By [Lemma 5.8\(d\)](#), we have $U \cong Q_J$; hence the statement holds. \square

We start by proving the following proposition by applying the method of change of orders given in [Theorem 2.3](#).

Proposition 6.9. *Assume that (A, e) models (Δ, J) . Then, for any subset J' of J , there exists an order A' , explicitly constructed from A , and an idempotent e' of A' such that (A', e') models (Δ, J') .*

Proof. First of all, using indices of [\(6-1\)](#), let $e' = \sum_{j \in J'} e_j$. Define $B := \Pi/I_J$ and $B' := \Pi/I_{J'}$. Then B' is a quotient of $A/(e')$. Let us check that (A, e') and B' satisfy the hypotheses of [Theorem 2.3](#). First of all, [\(C1\)](#) is clear. By [Lemma 6.8](#), $Q_{J'} \cong FX$ for some $X \in \text{CM}_e A$ without nonzero direct summands in $\text{add } Ae$. Moreover, according to [Proposition 5.9\(a\)](#), B -cotop $TX \cong \text{soc } Q_{J'}$ so $TX \cong Ae'$. Therefore, thanks to [Lemma 5.4](#), we get

$$B' \in \text{Sub } Q_{J'} \subset \text{Sub}(Ae' \otimes_R (K/R));$$

hence [\(C2\)](#) is satisfied. It is immediate that $\text{CM}_{e'}^{B'} A \subset \text{CM}_e A$ so, thanks to [\(E1\)](#), we get [\(C3\)](#) $\text{Ext}_A^1(\text{CM}_{e'}^{B'} A, Ae') = 0$.

We apply [Theorem 2.3](#) to the pair (A, e') and B' to get an explicit order A' . Let us show that (A', e') models (Δ, J') . We have $B' \cong A'/(e')$ by [Theorem 2.3\(a\)](#). Moreover, (A', e') satisfies [\(E1\)](#) and [\(E2\)⁺](#) by [Theorem 2.3\(b\)](#), so it also satisfies [\(E2\)](#). It remains to check for $j \in J'$ that B' -cotop $(A'e_j) \cong S_j$. Thanks to [Proposition 5.12](#) and [Lemma 5.13](#), applying H to $0 \rightarrow Ae_j \rightarrow B$ -corad $(Ae_j) \rightarrow S_j \rightarrow 0$ gives a short exact sequence $0 \rightarrow A'e_j \rightarrow H(B$ -corad $(Ae_j)) \rightarrow S_j \rightarrow 0$ which does not split. Moreover, $H(B$ -corad $(Ae_j)) \in \text{CM}_{e'} A'$ so S_j is a summand of B' -cotop $(A'e_j)$. So, thanks to [Lemma 5.8](#), B' -cotop $(A'e_j) \cong S_j$. \square

As a consequence, we obtain the following important result of this paper:

Theorem 6.10. *For any Dynkin diagram Δ and any set J of vertices of Δ , there exists a pair (A, e) which models (Δ, J) .*

Proof. As Π is self-injective, thanks to [Corollary C](#), there exist an order A and an idempotent e of A such that $A/(e) \cong \Pi$ as \mathbb{C} -algebras and $D_1(Ae) \cong (1 - e)A$ as right A -modules. So it is immediate that (A, e) models (Δ, Δ_0) , where Δ_0 is the set of vertices of Δ . Then, [Proposition 6.9](#) allows us to conclude immediately. \square

Notice that the pair (A, e) in [Theorem 6.10](#) is not unique. We will construct in [\[Demonet and Iyama \$\geq\$ 2016\]](#) other possibilities than the one considered in this paper.

We now fix a pair (Δ, J) and a pair (A, e) modeling it. We will prove that $\text{CM}_e A$ categorifies the cluster algebra structure of $\tilde{\mathcal{A}}$. From now on, we consider $F : \text{CM}_e A \rightarrow \text{Sub } Q_J$ as in [Lemma 6.8](#). Since the category $\text{Sub } Q_J$ is stably 2-Calabi–Yau, $\text{CM}_e A$ is also stably 2-Calabi–Yau. We now extend the character $\tilde{\varphi}$ to $\text{CM}_e A$:

Definition 6.11. For $Y \in \text{CM}_e A$, we define $\psi_Y \in \tilde{\mathcal{A}}$ as follows. If Y does not have nonzero direct summands in $\text{add } Ae$, then $\psi_Y := \tilde{\varphi}_{FY}$. For $j \in J$, we define $\psi_{Ae_j} := \Delta_j$, and we extend the definition to $\text{CM}_e A$ by the property $\psi_{Y \oplus Z} = \psi_Y \psi_Z$.

The following main result of this subsection improves [Theorem 6.6](#) of Geiss, Leclerc and Schröer:

Theorem 6.12. (a) ψ induces a bijection between

- isomorphism classes of reachable indecomposable rigid objects of $\text{CM}_e A$;
- cluster variables and coefficients of $\tilde{\mathcal{A}}$.

(b) ψ induces a bijection between

- isomorphism classes of reachable basic cluster tilting objects of $\text{CM}_e A$;
- clusters of $\tilde{\mathcal{A}}$.

Moreover, it commutes with mutation of cluster tilting objects and mutation of clusters.

We start by proving that ψ is a cluster character, extending [Theorem 6.5](#):

Proposition 6.13. (a) If $Y, Z \in \text{CM}_e A$, then $\psi_{Y \oplus Z} = \psi_Y \psi_Z$.

(b) If $Y, Z \in \text{CM}_e A$ are indecomposable and $\dim \text{Ext}_A^1(Y, Z) = 1$ (or equivalently $\dim \text{Ext}_A^1(Z, Y) = 1$), we have $\psi_Y \psi_Z = \psi_U + \psi_{U'}$, where

$$\xi_1 : 0 \rightarrow Y \rightarrow U \rightarrow Z \rightarrow 0 \quad \text{and} \quad \xi_2 : 0 \rightarrow Z \rightarrow U' \rightarrow Y \rightarrow 0$$

are two nonsplit short exact sequences.

We need the following lemma, stated without proof in [\[Geiss et al. 2008\]](#), which can also be seen as a corollary of the much more general [\[Geiss et al. 2011, Proposition 12.4\]](#). For the sake of convenience, we give a direct proof.

Lemma 6.14. For any $j \in J$, at least one of the following complexes is exact:

$$\text{Hom}_\Pi(S_j, F\xi_1) : 0 \rightarrow \text{Hom}_\Pi(S_j, FY) \rightarrow \text{Hom}_\Pi(S_j, FU) \rightarrow \text{Hom}_\Pi(S_j, FZ) \rightarrow 0,$$

$$\text{Hom}_\Pi(S_j, F\xi_2) : 0 \rightarrow \text{Hom}_\Pi(S_j, FZ) \rightarrow \text{Hom}_\Pi(S_j, FU') \rightarrow \text{Hom}_\Pi(S_j, FY) \rightarrow 0.$$

Proof. Applying F to ξ_1 and ξ_2 , we get short exact sequences $F\xi_1$ and $F\xi_2$. Applying $\text{Hom}_\Pi(S_j, -)$ to $F\xi_1$ and $F\xi_2$, it is enough to show that at least one of the induced morphisms

$$\text{Hom}_\Pi(S_j, FZ) \rightarrow \text{Ext}_\Pi^1(S_j, FY) \quad \text{and} \quad \text{Hom}_\Pi(S_j, FY) \rightarrow \text{Ext}_\Pi^1(S_j, FZ)$$

vanishes. Without loss of generality, suppose that there exists $f : S_j \hookrightarrow FZ$ such that the induced extension in $\text{Ext}_{\Pi}^1(S_j, FY)$ is nonzero. We deduce that

$$\text{Ext}_{\Pi}^1(f, FY) : \text{Ext}_{\Pi}^1(FZ, FY) \rightarrow \text{Ext}_{\Pi}^1(S_j, FY)$$

is nonzero, so injective as $\dim \text{Ext}_{\Pi}^1(FZ, FY) = 1$. As Π is stably 2-Calabi–Yau, we get that

$$\text{Ext}_{\Pi}^1(FY, f) : \text{Ext}_{\Pi}^1(FY, S_j) \rightarrow \text{Ext}_{\Pi}^1(FY, FZ)$$

is surjective, so there is a pushout diagram

$$\begin{array}{ccccccccc} 0 & \longrightarrow & S_j & \longrightarrow & M & \longrightarrow & FY & \longrightarrow & 0 \\ & & \downarrow f & & \downarrow & & \parallel & & \\ 0 & \longrightarrow & FZ & \longrightarrow & FU' & \longrightarrow & FY & \longrightarrow & 0 \end{array}$$

the second row of which is the image by F of the short exact sequence given in [Proposition 6.13\(b\)](#). So, as $\text{Ext}_{\Pi}^1(S_j, S_j) = 0$, any $g : S_j \rightarrow FY$ factors through M , and hence through FU' . Therefore, the map $\text{Hom}_{\Pi}(S_j, FY) \rightarrow \text{Ext}_{\Pi}^1(S_j, FZ)$ vanishes. \square

Proof of Proposition 6.13. (a) It is an obvious consequence of the property for $\tilde{\varphi}$ and our definition of ψ .

(b) Consider decompositions $U \cong U_0 \oplus U_1$ and $U' \cong U'_0 \oplus U'_1$, where U_1 and U'_1 are maximal direct summands contained in $\text{add } Ae$. Thanks to [Proposition 5.9\(b\)](#), we have

$$U_1 = \bigoplus_{j \in J} (Ae_j)^{a_j + b_j - c_j} \quad \text{and} \quad U'_1 = \bigoplus_{j \in J} (Ae_j)^{a_j + b_j - c'_j},$$

where, for $j \in J$,

- $a_j = \dim \text{Hom}_{\Pi/I_j}(S_j, FY) = \dim \text{Hom}_{\Pi}(S_j, FY)$;
- $b_j = \dim \text{Hom}_{\Pi/I_j}(S_j, FZ) = \dim \text{Hom}_{\Pi}(S_j, FZ)$;
- $c_i = \dim \text{Hom}_{\Pi/I_j}(S_j, FU) = \dim \text{Hom}_{\Pi}(S_j, FU)$;
- $c'_i = \dim \text{Hom}_{\Pi/I_j}(S_j, FU') = \dim \text{Hom}_{\Pi}(S_j, FU')$.

By [Lemma 6.14](#), using the α_j and β_j of [Theorem 6.5](#), we have $a_j + b_j - c_j = \max(0, c'_j - c_j) = \alpha_j$ and $a_j + b_j - c'_j = \beta_j$. Thus, [Theorem 6.5](#) implies

$$\begin{aligned} \psi_Y \psi_Z &= \tilde{\varphi}_{FY} \tilde{\varphi}_{FZ} = \tilde{\varphi}_{FU} \prod_{j \in J} \Delta_j^{\alpha_j} + \tilde{\varphi}_{FU'} \prod_{j \in J} \Delta_j^{\beta_j} \\ &= \psi_{U_0} \psi_{U_1} + \psi_{U'_0} \psi_{U'_1} = \psi_U + \psi_{U'}. \end{aligned} \quad \square$$

Now, we can deduce the proof of [Theorem 6.12](#):

Proof of Theorem 6.12. By Theorem 6.6, it is enough to note that $F: \text{CM}_e A \rightarrow \text{Sub } U$ induces a bijection between isomorphism classes of basic cluster tilting objects. This is immediate as F induces a triangle equivalence $\underline{\text{CM}}_e A \cong \underline{\text{Sub}} U$. More precisely, basic cluster tilting objects of $\text{CM}_e A$ are of the form $Ae \oplus T$, where T has no direct summand in $\text{add } Ae$, and the indecomposable direct summands of T correspond bijectively to the indecomposable direct summands of FT . \square

Acknowledgement

We would like to thank Alastair King and Bernard Leclerc for valuable discussion about this topic.

References

- [Amiot et al. 2015] C. Amiot, O. Iyama, and I. Reiten, “Stable categories of Cohen–Macaulay modules and cluster categories”, *Amer. J. Math.* **137**:3 (2015), 813–857. [MR 3357123](#) [Zbl 06458529](#)
- [Araya 1999] T. Araya, “Exceptional sequences over graded Cohen–Macaulay rings”, *Math. J. Okayama Univ.* **41** (1999), 81–102. [MR 1816620](#) [Zbl 0981.16016](#)
- [Auslander 1978] M. Auslander, “Functors and morphisms determined by objects”, pp. 1–244 in *Representation theory of algebras* (Philadelphia, PA, 1976), edited by R. Gordon, Lecture Notes in Pure Appl. Math. **37**, Dekker, New York, 1978. [MR 0480688](#) [Zbl 0383.16015](#)
- [Auslander and Reiten 1991] M. Auslander and I. Reiten, “Applications of contravariantly finite subcategories”, *Adv. Math.* **86**:1 (1991), 111–152. [MR 1097029](#) [Zbl 0774.16006](#)
- [Baur et al. 2016] K. Baur, A. King, and R. J. Marsh, “Dimer models and cluster categories of Grassmannians”, *Proc. London Math. Soc.* **113**:2 (2016), 213–260.
- [Berenstein et al. 2005] A. Berenstein, S. Fomin, and A. Zelevinsky, “Cluster algebras, III: Upper bounds and double Bruhat cells”, *Duke Math. J.* **126**:1 (2005), 1–52. [MR 2110627](#) [Zbl 1135.16013](#)
- [Borel 1991] A. Borel, *Linear algebraic groups*, 2nd ed., Graduate Texts in Mathematics **126**, Springer, New York, 1991. [MR 1102012](#) [Zbl 0726.20030](#)
- [Chen 2012] X.-W. Chen, “Three results on Frobenius categories”, *Math. Z.* **270**:1–2 (2012), 43–58. [MR 2875822](#) [Zbl 1244.18004](#)
- [Curtis and Reiner 1981] C. W. Curtis and I. Reiner, *Methods of representation theory, I: With applications to finite groups and orders*, Wiley, New York, 1981. [MR 632548](#) [Zbl 0469.20001](#)
- [Demonet and Iyama \geq 2016] L. Demonet and O. Iyama, “Idempotent-projective Cohen–Macaulay modules and their Auslander–Reiten quiver”, work in progress.
- [Demonet and Luo 2016a] L. Demonet and X. Luo, “Ice quivers with potential arising from once-punctured polygons and Cohen–Macaulay modules”, *Publ. Res. Inst. Math. Sci.* **52**:2 (2016), 141–205. [MR 3490479](#) [Zbl 06588940](#)
- [Demonet and Luo 2016b] L. Demonet and X. Luo, “Ice quivers with potential associated with triangulations and Cohen–Macaulay modules over orders”, *Trans. Amer. Math. Soc.* **368**:6 (2016), 4257–4293. [MR 3453371](#) [Zbl 06551092](#)
- [Fomin and Zelevinsky 1999] S. Fomin and A. Zelevinsky, “Double Bruhat cells and total positivity”, *J. Amer. Math. Soc.* **12**:2 (1999), 335–380. [MR 1652878](#) [Zbl 0913.22011](#)
- [Fomin and Zelevinsky 2003] S. Fomin and A. Zelevinsky, “Cluster algebras, II: Finite type classification”, *Invent. Math.* **154**:1 (2003), 63–121. [MR 2004457](#) [Zbl 1054.17024](#)

- [Geiss et al. 2005] C. Geiss, B. Leclerc, and J. Schröer, “Semicanonical bases and preprojective algebras”, *Ann. Sci. École Norm. Sup. (4)* **38**:2 (2005), 193–253. [MR 2144987](#) [Zbl 1131.17006](#)
- [Geiss et al. 2008] C. Geiss, B. Leclerc, and J. Schröer, “Partial flag varieties and preprojective algebras”, *Ann. Inst. Fourier (Grenoble)* **58**:3 (2008), 825–876. [MR 2427512](#) [Zbl 1151.16009](#)
- [Geiss et al. 2011] C. Geiss, B. Leclerc, and J. Schröer, “Kac–Moody groups and cluster algebras”, *Adv. Math.* **228**:1 (2011), 329–433. [MR 2822235](#) [Zbl 1232.17035](#)
- [Herschend et al. 2014] M. Herschend, O. Iyama, H. Minamoto, and S. Oppermann, “Representation theory of Geigle–Lenzing complete intersections”, preprint, 2014. [arXiv 1409.0668](#)
- [Iyama and Takahashi 2013] O. Iyama and R. Takahashi, “Tilting and cluster tilting for quotient singularities”, *Math. Ann.* **356**:3 (2013), 1065–1105. [MR 3063907](#) [Zbl 06181402](#)
- [Jensen et al. 2016] B. T. Jensen, A. King, and X. Su, “A categorification of Grassmannian cluster algebras”, *Proc. London Soc.* **113**:2 (2016), 185–212.
- [Kajiura et al. 2007] H. Kajiura, K. Saito, and A. Takahashi, “Matrix factorizations and representations of quivers, II: Type ADE case”, *Adv. Math.* **211**:1 (2007), 327–362. [MR 2313537](#) [Zbl 1167.16011](#)
- [Kajiura et al. 2009] H. Kajiura, K. Saito, and A. Takahashi, “Triangulated categories of matrix factorizations for regular systems of weights with $\epsilon = -1$ ”, *Adv. Math.* **220**:5 (2009), 1602–1654. [MR 2493621](#) [Zbl 1172.18002](#)
- [Keller 1990] B. Keller, “Chain complexes and stable categories”, *Manuscripta Math.* **67**:4 (1990), 379–417. [MR 1052551](#) [Zbl 0753.18005](#)
- [Keller and Reiten 2008] B. Keller and I. Reiten, “Acyclic Calabi–Yau categories”, *Compos. Math.* **144**:5 (2008), 1332–1348. [MR 2457529](#) [Zbl 1171.18008](#)
- [Lakshmibai and Gonciulea 2001] V. Lakshmibai and N. Gonciulea, *Flag varieties*, Travaux en Cours **63**, Hermann, Paris, 2001. [Zbl 1136.14306](#)
- [Leuschke and Wiegand 2012] G. J. Leuschke and R. Wiegand, *Cohen–Macaulay representations*, Mathematical Surveys and Monographs **181**, American Mathematical Society, Providence, RI, 2012. [MR 2919145](#) [Zbl 1252.13001](#)
- [Lusztig 2000] G. Lusztig, “Semicanonical bases arising from enveloping algebras”, *Adv. Math.* **151**:2 (2000), 129–139. [MR 1758244](#) [Zbl 0983.17009](#)
- [Quillen 1973] D. Quillen, “Higher algebraic K -theory, I”, pp. 85–147 in *Algebraic K-theory, I: Higher K-theories* (Seattle, WA, 1972), Lecture Notes in Math. **341**, Springer, Berlin, 1973. [MR 0338129](#) [Zbl 0292.18004](#)
- [Scott 2006] J. S. Scott, “Grassmannians and cluster algebras”, *Proc. London Math. Soc. (3)* **92**:2 (2006), 345–380. [MR 2205721](#) [Zbl 1088.22009](#)
- [Simson 1992] D. Simson, *Linear representations of partially ordered sets and vector space categories*, Algebra, Logic and Applications **4**, Gordon and Breach Science Publishers, Montreux, 1992. [MR 1241646](#) [Zbl 0818.16009](#)
- [de Thanhoffer de Völcsey and Van den Bergh 2010] L. de Thanhoffer de Völcsey and M. Van den Bergh, “Explicit models for some stable categories of maximal Cohen–Macaulay modules”, preprint, 2010. To appear in *Math. Res. Lett.* [arXiv 1006.2021](#)
- [Yoshino 1990] Y. Yoshino, *Cohen–Macaulay modules over Cohen–Macaulay rings*, London Mathematical Society Lecture Note Series **146**, Cambridge University Press, 1990. [MR 1079937](#) [Zbl 0745.13003](#)

Communicated by Sergey Fomin

Received 2015-09-25

Revised 2016-04-26

Accepted 2016-06-13

laurent.demonet@normalesup.org *Graduate School of Mathematics, Nagoya University,
Furocho, Chikusaku, Nagoya 464-8602, Japan*

iyama@math.nagoya-u.ac.jp *Graduate School of Mathematics, Nagoya University,
Furocho, Chikusaku, Nagoya 464-8602, Japan*

A fibered power theorem for pairs of log general type

Kenneth Ascher and Amos Turchet

Let $f : (X, D) \rightarrow B$ be a stable family with log canonical general fiber. We prove that, after a birational modification of the base $\tilde{B} \rightarrow B$, there is a morphism from a high fibered power of the family to a pair of log general type. If in addition the general fiber is openly canonical, then there is a morphism from a high fibered power of the original family to a pair openly of log general type.

1. Introduction

We work over an algebraically closed field of characteristic 0.

Analyzing the geometry of fibered powers of families of varieties has been pivotal in showing that well known conjectures in Diophantine geometry imply uniform boundedness of rational points on algebraic varieties of general type. Caporaso, Harris, and Mazur showed in a celebrated paper [Caporaso et al. 1997] that various versions of Lang’s conjecture imply uniform boundedness of rational points on curves of general type. More precisely, they show that, assuming Lang’s conjecture, for every number field K and integer $g \geq 2$, there exists an integer $B(K, g)$ such that no smooth curve of genus $g \geq 2$ defined over K has more than $B(K, g)$ rational points. Similar statements were proven for the case of surfaces of general type in [Hassett 1996], and eventually all positive-dimensional varieties of general type in [Abramovich 1997a] and [Abramovich and Voloch 1996]. The essence of these papers is a purely algebro-geometric statement: the proof of a “fibered power theorem”, which analyzes the behavior of families of varieties of general type.

The goal of our current research program is to apply birational geometry and moduli theory to show that the *Vojta–Lang conjecture* (see [Conjecture 1.3](#)) implies uniform boundedness of *stably integral points* (see [Abramovich 1997b]) on varieties of *log general type*. In short, our objective is to generalize the uniformity results mentioned above from varieties of general type to pairs of log general type. The first step is a generalization of the fibered power theorem alluded to above to the

Research of Ascher supported in part by funds from NSF grant DMS-1162367.

MSC2010: primary 14J10; secondary 14J29, 14E99, 14G05.

Keywords: log general type, moduli of stable pairs, Lang–Vojta.

context of pairs, and we take the goal of this paper to be the proof of the following theorem:

Theorem 1.1. *Let $(X, D) \rightarrow B$ be a stable family with integral and log canonical general fiber over a smooth projective variety B . Then after a birational modification of the base $\tilde{B} \rightarrow B$, there exists an integer $n > 0$, a positive-dimensional pair $(\tilde{W}, \tilde{\Delta})$ of log general type, and a morphism $(\tilde{X}_B^n, \tilde{D}_n) \rightarrow (\tilde{W}, \tilde{\Delta})$.*

Moreover, with an additional assumption on the singularities of the general fiber, we can avoid a modification of the base:

Theorem 1.2. *Let $(X, D) \rightarrow B$ be a stable family with integral, openly canonical, and log canonical general fiber (see [Definition 1.6](#)) over a smooth projective variety B . Then there exists an integer $n > 0$, a positive-dimensional pair (W, Δ) openly of log general type, and a morphism $(X_B^n, D_n) \rightarrow (W, \Delta)$.*

We state two theorems to satisfy the two competing definitions of *log general type*, one which often appears in birational geometry, and one which is useful for arithmetic applications. To remove any ambiguity, we refer to the former as a pair of log general type, and the latter as a pair openly of log general type. See [Definitions 1.4](#) and [1.5](#) for precise definitions.

Next, we wish to briefly outline how the previous theorem can be used for arithmetic applications. The analogue of Lang’s conjecture in the setting of pairs is the following conjecture, due to Vojta and reformulated using ideas of Lang.

Conjecture 1.3 (Vojta–Lang). *Let K be a number field and let S be a finite set of places of K . Let (X, D) be a pair openly of log general type defined over K . Then the set of S -integral points of $X \setminus D$ is not Zariski dense.*

Given a stable family, [Theorem 1.2](#) gives a morphism from a high fibered power of this family to a pair (W, Δ) openly of log general type. [Conjecture 1.3](#) then predicts that the integral points of $W \setminus \Delta$ are not Zariski dense. This allows us to prove in a forthcoming article uniformity results for integral points on higher-dimensional pairs of log general type assuming that the Vojta–Lang conjecture holds.

Definition 1.4. A pair (X, D) of a proper variety X and an effective \mathbb{Q} -divisor D is of *log general type* if

- (X, D) has log canonical singularities, and
- $\omega_X(D)$ is big.

For applications to arithmetic (in forthcoming work) it will be useful to consider the following.

Definition 1.5. Let X be a quasiprojective variety and let $\tilde{X} \rightarrow X$ be a desingularization. Let $\tilde{X} \subset Y$ by a projective embedding and suppose $D = Y \setminus \tilde{X}$ is a divisor of normal crossings. Then X is *openly of log general type* if $\omega_Y(D)$ is big.

This second definition is independent of both the choice of the desingularization as well as the embedding; it is also a birational invariant. Definitions 1.4 and 1.5 are equivalent if the pair (X, D) has log canonical singularities and one considers the variety $X \setminus (D \cup \text{Sing}(X))$.

Just to reiterate, we will refer to Definition 1.4 by saying (X, D) is a *pair of log general type*. We will refer to Definition 1.5 by stating that the pair is *openly of log general type*, as the definition is motivated by considering the complement $X \setminus D$. Throughout the course of this paper, we will take care to specify which definition we are using.

Definition 1.6. By *openly canonical*, we mean that the variety $X \setminus D$ has canonical singularities.

For definitions of canonical, log canonical singularities, and stable pairs, see Definitions 2.2 and 2.6.

Ideas of proof. To prove Theorem 1.1, we show that it suffices to prove this:

Theorem 4.12. *Let $(X, D) \rightarrow B$ be a stable family with integral and log canonical general fiber over a smooth projective variety B . Suppose that the variation of the family f is maximal (see Definition 2.9). Let G be a finite group such that $(X, D) \rightarrow B$ is G -equivariant. Then there exists an integer $n > 0$ such that the quotient $(X_B^n/G, D_n/G)$ of the pair by a finite group of automorphisms is of log general type.*

Similarly, to prove Theorem 1.2, it suffices to prove the following:

Theorem 4.9. *Let $f : (X, D) \rightarrow B$ be a stable family with integral, openly canonical, and log canonical general fiber over a smooth projective variety B . Suppose that the variation of the family f is maximal. Let G be a finite group such that $(X, D) \rightarrow B$ is G -equivariant. Then there exists an integer $n > 0$ such that the quotient $(X_B^n/G, D_n/G)$ is openly of log general type.*

For a definition of maximal variation, see Definition 2.9.

We then obtain Theorem 1.2 by means of Theorem 1.1 and Theorem 4.12. More specifically, we show that there is a birational transformation $(\tilde{W}, \tilde{\Delta}) \rightarrow (W, \Delta)$ such that $(\tilde{W}, \tilde{\Delta})$ manifests (W, Δ) as a pair openly of log general type.

The main tool of this paper is a recent result of Kovács–Patakfalvi which says that given a stable family with maximal variation $f : (X, D_\epsilon) \rightarrow B$ where the general fiber is Kawamata log terminal (klt), then for large m the sheaf $f_*(\omega_f(D_\epsilon))^m$ is big [Kovács and Patakfalvi 2015, Theorem 7.1]. Here, the divisor D_ϵ denotes the divisor with lowered coefficients $(1 - \epsilon)D$ for a small rational number ϵ . Unfortunately their result does *not* hold for log canonical pairs; see Example 7.5 of [Kovács and Patakfalvi 2015]. As a result, since D is not assumed to be \mathbb{Q} -Cartier, one obstacle

of this paper is showing that bigness of $\omega_{X_B^n}(D_{\epsilon,n})$ for some n large enough allows you to conclude bigness of $\omega_{X_B^n}(D_n)$. To do so, one must first take a \mathbb{Q} -factorial dlt modification, followed by a relative log canonical model. The ideas here are present in Propositions 2.9 and 2.15 of [Patakfalvi and Xu 2015]. See Remark 3.5 for a more detailed discussion.

Finally, we must guarantee that the fibered powers are not too singular. A priori, it is unclear if taking high fibered powers to ensure the positivity of $\omega_{X_B^n}(D_n)$ leads to a pair with good singularities. This is ensured by the following statement.

Proposition 4.4. *Let $f : (X, D) \rightarrow B$ be a stable family with integral and log canonical general fiber over a smooth projective variety B . Then for all $n > 0$, the fibered powers (X_B^n, D_n) have log canonical singularities.*

This also works after taking quotients by finite groups of automorphisms:

Corollary 4.10. *Let $f : (X, D) \rightarrow B$ be an slc family with integral and log canonical general fiber over a smooth projective variety B . Then for n large enough, the quotient pair $(X_B^n/G, D_n/G)$ also has log canonical singularities.*

In fact, although we do not use it in this paper, we prove:

Proposition 4.6. *The total space of the fiber product of stable families over a stable base is stable.*

The main result we seek then follows via the above methods after applying standard tools from moduli theory.

Previous work. The general ideas present in this paper originated in the work of Caporaso, Harris, and Mazur, who showed in [Caporaso et al. 1997] that the fibered power theorem is true for families of curves of general type, i.e., families with general fiber smooth curves of genus $g \geq 2$. More precisely, they proved the following theorem.

Theorem 1.7 [Caporaso et al. 1997, Theorem 1.3]. *Let $f : X \rightarrow B$ be a proper morphism of integral varieties whose general fiber is a smooth curve of genus $g \geq 2$. Then for n sufficiently large, X_B^n admits a dominant rational map $h : X_B^n \rightarrow W$ to a positive-dimensional variety of general type W .*

In this same paper, the authors conjectured that this result is actually true for families of varieties of general type of arbitrary dimension. However, they focused only on the case of curves, as their results relied upon the nice description of a compact moduli space parametrizing mildly singular objects: the moduli space of genus g stable curves, $\overline{\mathcal{M}}_g$. After Alexeev, Kollár, and Shepherd-Barron constructed a moduli space parametrizing stable surfaces analogous to that of stable curves, Hassett [1996] showed that the correlation theorem was also true for families of surfaces of general type. Abramovich [1997a] later proved the fibered power

theorem for varieties of general type of arbitrary dimension, using an analogue of semistable reduction.

Abramovich and Matsuki [2001] proved a fibered power theorem for principally polarized abelian varieties, using Alexeev's compact moduli space. This was a generalization of some prior results which considered pairs of elliptic curves and their origins; see [Pacelli 1997; 1999; Abramovich 1997b]. Furthermore, Abramovich and Matsuki remark that the result should in fact be true for stable pairs (X, D) , and so we take this as the goal of this paper.

Finally, although we hope that this result will be of interest in its own right from the viewpoint of geometry, there are numerous applications to arithmetic, namely to the study of integral points on pairs of log general type, assuming the Lang–Vojta conjecture. This approach was taken in all the papers mentioned above and we obtain similar results in this direction (to appear).

Outline.

- **Section 2:** Preliminary definitions and notation.
- **Section 3:** We prove that $\omega_{X_B^n}(D_n)$ is big for a stable family of maximal variation with log canonical general fiber, and that the fibered power theorem holds for max variation families when the general fiber is both openly canonical and log canonical.
- **Section 4:** Some results on singularities, namely we analyze the singularities of fibered powers and study the affect of group quotients, and we prove the fibered power theorem for log canonical general fiber in the case of max variation.
- **Section 5:** We prove the full fibered power theorems by reducing to families of maximal variation.

2. Preliminaries and notation

Birational geometry.

Definition 2.1. A line bundle \mathcal{L} on a proper variety X is called *big* if the global sections of \mathcal{L}^m define a birational map for $m > 0$. A Cartier divisor D is called big if $\mathcal{O}_X(D)$ is big.

From the point of view of birational geometry and the minimal model program, it has become convenient and standard to work with pairs. We define a pair (X, D) to be a variety X along with an effective \mathbb{R} -divisor $D = \sum d_i D_i$ which is a linear combination of distinct prime divisors.

Definition 2.2. Let (X, D) be a pair where X is a normal variety and $K_X + D$ is \mathbb{Q} -Cartier. Suppose that there is a log resolution $f : Y \rightarrow X$ such that

$$K_Y + \sum a_E E = f^*(K_X + D),$$

where the sum goes over all irreducible divisors on Y . We say that (X, D) is

- *canonical* if all $a_E \leq 0$,
- *log canonical* (lc) if all $a_E \leq 1$, and
- *Kawamata log terminal* (klt) if all $a_E < 1$.

Remark 2.3. In particular, for a klt pair, the coefficients d_i in the decomposition $D = \sum d_i D_i$ are all *strictly* < 1 . Similarly, for a lc pair, the coefficients are ≤ 1 .

Definition 2.4. A pair $(X, D = \sum d_i D_i)$ is *semilog canonical* (slc) if X is reduced, $K_X + D$ is \mathbb{Q} -Cartier, and

- (1) the variety X satisfies Serre’s condition S2,
- (2) X is Gorenstein in codimension one, and
- (3) if $\nu : X^\nu \rightarrow X$ is the normalization, then the pair $(X^\nu, \sum d_i \nu^{-1}(D_i) + D^\vee)$ is log canonical, where D^\vee denotes the preimage of the double locus on X^ν .

Remark 2.5. Semilog canonical singularities can be thought of as the extension of log canonical singularities to nonnormal varieties. The only difference is that a log resolution is replaced by a *good semiresolution*.

Definition 2.6. A pair (X, D) of a proper variety X and an effective \mathbb{Q} -divisor D , is a *stable pair* if

- the line bundle $\omega_X(D)$ is ample and
- the pair (X, D) has semilog canonical singularities.

We assume that all of our families of pairs satisfy *Kollár’s condition*. To be precise, we define a stable family as follows. Let X be a variety and \mathcal{F} an \mathcal{O}_X -module. The dual of \mathcal{F} is denoted $\mathcal{F}^* := \text{Hom}_X(\mathcal{F}, \mathcal{O}_X)$ and we define the m -th reflexive power of \mathcal{F} to be the double dual (or reflexive hull) of the m -th tensor power of \mathcal{F} :

$$\mathcal{F}^{[m]} := (\mathcal{F}^{\otimes m})^{**}.$$

Definition 2.7. An *slc family* is a flat morphism $f : (X, D) \rightarrow B$ such that

- each fiber (X_b, D_b) is an slc pair,
- $\omega_f(D)^{[m]}$ is flat, and
- (Kollár’s condition) for every base change $\tau : B' \rightarrow B$, given the induced morphism $\rho : (X_{B'}, D_{B'}) \rightarrow (X, D)$ we have that the natural homomorphism

$$\rho^*(\omega_f(D)^{[m]}) \rightarrow \omega_{f'}(D)^{[m]}$$

is an isomorphism.

We say that $f : (X, D) \rightarrow B$ is a *stable family* if in addition to the above, each (X_b, D_b) is a stable pair. Equivalently, $K_{X_b} + D_b$ is ample for every $b \in B$.

Moduli space of stable pairs. Constructing the moduli space of stable pairs, denoted below by \overline{M}_h , has been a difficult task. A discussion of the construction of the moduli space \overline{M}_h is not necessary for this paper, but for sake of completeness we note that there exists a finite set of constants, which we denote by h , that allows for a compact moduli space. As long as the coefficients d_i appearing in the divisor decomposition are all $> \frac{1}{2}$, there are no issues and we do in fact have a well defined moduli space. There is no harm in assuming this outright, which leads to the following:

Assumption 2.8. The coefficients of the divisors considered are always $> \frac{1}{2}$.

We refer the reader to [Kollár 2010] or to the introduction of [Kovács and Patakfalvi 2015] for more details.

Variation of moduli. Given a stable family $f : (X, D) \rightarrow B$, we obtain a *canonical morphism*

$$\phi : B \rightarrow \overline{M}_h$$

sending a point $b \in B$ to the point of the moduli space \overline{M}_h of stable pairs, classifying the fiber (X_b, D_b) . This motivates the following definition.

Definition 2.9. A family has *maximal variation* of moduli if the corresponding canonical morphism is generically finite.

Equivalently, the above definition means that the family is a truly varying family, diametrically opposed to one which is *isotrivial*, where the fibers do not vary at all.

Notation. Given a morphism of pairs $f : (X, D) \rightarrow B$, we denote by (X_B^n, D_n) the unique irreducible component of the n -th fiber product of (X, D) over B dominating B . We define D_n to be the divisor $D_n := \sum_{i=1}^n \pi_i^*(D)$ where the maps $\pi_i : (X_B^n, D_n) \rightarrow B$ denote the projections onto the i -th factors. We denote by f_n the maps $f_n : (X_B^n, D_n) \rightarrow B$. Finally, we denote by D_ϵ the divisor $(1 - \epsilon)D$ and by $D_{\epsilon,n}$ the sum $D_{\epsilon,n} := \sum_{i=1}^n \pi_i^*(D_\epsilon)$.

3. Positivity of the relative anticanonical sheaf

Recall that to prove that the pair (X_B^n, D_n) is a *pair of log general type*, we must show that

- (a) $\omega_{X_B^n}(D_n)$ is big, and
- (b) the pair (X_B^n, D_n) has log canonical singularities.

We also remind the reader that we will demonstrate in Section 4 that Theorem 4.12 implies Theorem 1.1. Therefore, in this section we assume that the variation of our family is maximal. More precisely, the goal of this section is to prove the following proposition, tackling property (a).

Proposition 3.1. *Let $f : (X, D) \rightarrow B$ be a stable family with maximal variation over a smooth, projective variety B with integral and log canonical general fiber. Then for n sufficiently large, the sheaf $\omega_{X_B^n}(D_n)$ is big.*

As mentioned in the introduction, we will prove this by means of a slightly weaker statement:

Proposition 3.2. *Let $f : (X, D_\epsilon) \rightarrow B$ be a stable family with maximal variation over a smooth, projective variety B with klt general fiber. Then for n sufficiently large, the sheaf $\omega_{X_B^n}(D_{\epsilon,n})$ is big.*

Our proof of [Proposition 3.2](#) requires a recent theorem of Kovács and Patakfalvi:

Theorem 3.3 [[Kovács and Patakfalvi 2015](#), Theorem 7.1 and Corollary 7.3]. *If $f : (X, D_\epsilon) \rightarrow B$ is a stable family with maximal variation over a normal, projective variety B with klt general fiber, then $f_*(\omega_f(D_\epsilon)^m)$ is big for m large enough. Moreover, $\omega_f(D_\epsilon)$ is big.*

Let $S^{[n]}$ denote the reflexive hull of the n -th symmetric power of a sheaf. Then the above theorem is equivalent to saying that, under the hypotheses, for any ample line bundle H on B there exists an integer n_0 such that

$$S^{[n_0]}(f_*(\omega_f(D_\epsilon)^m)) \otimes H^{-1} \tag{1}$$

is generically globally generated. We desire to show that this implies [Proposition 3.2](#); this essentially follows from Proposition 5.1 of [[Hassett 1996](#)], but we include the proof for completeness to show how it extends to the case of pairs. We begin with a lemma.

Lemma 3.4. *Let $f : (X, D) \rightarrow B$ be a stable family over a smooth projective variety B such that the general fiber has log canonical singularities. Then for all $n > 0$, the following formula holds:*

$$\omega_{X_B^n}(D_n)^{[m]} = \pi_1^* \omega_f(D)^{[m]} \otimes \dots \otimes \pi_n^* \omega_f(D)^{[m]} \otimes f_n^* \omega_B^m.$$

Proof. Recall that the relative dualizing sheaf satisfies the equation

$$\omega_{f_n}(D_n) = \pi_1^* \omega_f(D) \otimes \dots \otimes \pi_n^* \omega_f(D),$$

where π_j denotes the projection $\pi_j : X^n \rightarrow X$ to the j -th factor. Since B is smooth we obtain

$$\omega_{X_B^n}(D_n)^{[m]} = \omega_{f_n}(D_n)^{[m]} \otimes f_n^* \omega_B^m.$$

Since $f : (X, D) \rightarrow B$ is a stable family, there exists an integer m such that for all $b \in B$, the sheaf $\omega_f(D)^{[m]}|_{X_b}$ is locally free. Moreover, since this sheaf is locally free on each fiber, $\omega_f(D)^{[m]}$ is also locally free for this m . We claim that

$$\omega_{X_B^n}(D_n)^{[m]} = \pi_1^* \omega_f(D)^{[m]} \otimes \dots \otimes \pi_n^* \omega_f(D)^{[m]} \otimes f_n^* \omega_B^m.$$

Both sides of the equation are reflexive — the left-hand side by construction, and the right-hand side because it is the tensor product of locally free sheaves. Therefore, to prove the equivalence, we must show the two sides agree on an open set whose complement has codimension at least two. Consider the locus consisting of both the general fibers, which are log canonical and hence \mathbb{Q} -Gorenstein, as well as the nonsingular parts of the special fibers. Note that the complement of this locus is of codimension at least two, because the singular parts of the special fiber are of codimension one, thus of at least codimension two in the total space. \square

Proof of Proposition 3.2. Let $m \in \mathbb{Z}$ be such that both $\omega_f(D_\epsilon)^{[m]}$ is locally free and $f_*(\omega_f(D_\epsilon)^m)$ is big. First note that for n large enough, the sheaf

$$(f_*(\omega_f(D_\epsilon)^m))^{[n]} \otimes H^{-1}$$

is generically globally generated. This follows since by Proposition 5.2 of [Hassett 1996], for an r -dimensional vector space V , each irreducible component of the reflexive hull of the m -th tensor power of V is a quotient of a representation $S^{[q_1]}(V) \otimes \dots \otimes S^{[q_k]}(V)$, where $k = r!$. Using this, we prove that $\omega_{X_B^n}(D_{\epsilon,n})$ is big for large n . To do so, it suffices to show that there are on the order of $m^{n \dim X_\eta + b}$ sections of $\omega_{X_B^n}(D_\epsilon)^{[m]}$, where $b = \dim B$ and X_η denotes the general fiber.

By Lemma 3.4,

$$\omega_{X_B^n}(D_{\epsilon,n})^{[m]} = \pi_1^* \omega_f(D_\epsilon)^{[m]} \otimes \dots \otimes \pi_n^* \omega_f(D_\epsilon)^{[m]} \otimes f_n^* \omega_B^m.$$

The sheaf $\omega_f(D_\epsilon)$ has good positivity properties — it is big by Corollary 7.3 of [Kovács and Patakfalvi 2015], but the sheaf ω_B is somewhat arbitrary and could easily prevent $\omega_{X_B^n}(D_{\epsilon,n})$ from being big. However, taking high enough powers of X allows the positivity of $\omega_f(D_\epsilon)$ to overcome the possible negativity of ω_B .

Applying $(f_n)_*$ gives, via the projection formula,

$$(f_n)_*(\omega_{X_B^n}(D_{\epsilon,n})^{[m]}) = (f_*(\omega_f(D_\epsilon)^{[m]}))^n \otimes \omega_B^m,$$

which is also a reflexive sheaf by Corollary 1.7 of [Hartshorne 1980]. More specifically, it is the pushforward of a reflexive sheaf under a proper dominant morphism. Then the inclusion map $\omega_f(D_\epsilon)^m \rightarrow \omega_f(D_\epsilon)^{[m]}$ induces a map of reflexive sheaves:

$$(f_* \omega_f(D_\epsilon)^m)^{[n]} \rightarrow (f_* \omega_f(D_\epsilon)^{[m]})^n = (f_n)_*(\omega_{X_B^n}(D_{\epsilon,n})^{[m]}) \otimes \omega_B^{-m},$$

which is an isomorphism at the generic point of B .

Let H be an invertible sheaf on B such that $H \otimes \omega_B$ is very ample. Then we can choose n so that $(f_* \omega_f(D_\epsilon)^m)^{[n]} \otimes H^{-m}$ is generically globally generated for all admissible values of m . But then

$$(f_* \omega_f(D_\epsilon)^m)^{[n]} \otimes H^{-m} = (f_n)_*(\omega_{X_B^n}(D_{\epsilon,n})^{[m]}) \otimes (H \otimes \omega_B)^{-m}$$

is also generically globally generated for the same m .

This sheaf has rank on the order of $m^{n \dim X_\eta}$, so there are at least this many global sections. By our assumption on H , we have that $(H \otimes \omega_B)^m$ has on the order of m^b sections varying horizontally along the base B . By tensoring, we obtain that the sheaf

$$(f_n)_*(\omega_{X_B^n}(D_{\epsilon,n}))^{[m]}$$

has on the order of $m^{n \dim X_\eta + b}$ global sections, and therefore $\omega_{X_B^n}(D_{\epsilon,n})$ is big. \square

Remark 3.5. Proposition 3.2 assumed that the general fiber (X_b, D_b) had klt singularities, but to prove Theorem 1.1 as stated, we must allow the general fiber to have log canonical singularities. Unfortunately, we cannot just raise the coefficients of D so that the pair has log canonical singularities, via twisting by ϵD to conclude that $\omega_{X_B^n}(D_n)$ is also big. This is because we do *not* know that the divisor D is \mathbb{Q} -Cartier. We remedy this situation with a \mathbb{Q} -factorial divisorial log terminal (dlt) modification (see Section 1.4 of [Kollár 2013] for an overview of dlt models), as explained below.

First, the definition of a dlt pair:

Definition 3.6. Let (X, D) be a log canonical pair such that X is normal and $D = \sum d_i D_i$ is the sum of distinct prime divisors. Then (X, D) is *divisorial log terminal* (dlt) if there exists a closed subset $Z \subset X$ such that

- (1) $X \setminus Z$ is smooth and $D|_{X \setminus Z}$ is an snc divisor;
- (2) if $f : Y \rightarrow X$ is birational and $E \subset Y$ is an irreducible divisor such that $\text{center}_X E \subset Z$, then the discrepancy $a(E, X, D) < 1$.

See Definition 2.25 in [Kollár and Mori 1998] for a definition of the discrepancy of a divisor E with respect to a pair (X, D) .

Roughly speaking, a pair (X, D) is dlt if it is log canonical, and it is simple normal crossings at the places where it is not klt. The following theorem of Hacon guarantees the existence of dlt modifications.

Theorem 3.7 [Kollár and Kovács 2010, Theorem 3.1]. *Let (X, D) be a pair of a projective variety X and a divisor $D = \sum d_i D_i$ with coefficients $0 \leq d_i \leq 1$, such that $K_X + D$ is \mathbb{Q} -Cartier. Then (X, D) admits a \mathbb{Q} -factorial mini dlt model $f^{\min} : (X^{\min}, D^{\min}) \rightarrow (X, D)$.*

The upshot here is that, starting with a log canonical pair (X, D) we can obtain a model which is dlt and \mathbb{Q} -factorial.

The statement that we will actually apply follows from [Patakfalvi and Xu 2015, Proposition 2.9]:

Proposition 3.8. *Let $f : (X, D) \rightarrow B$ be a stable family over a smooth variety B . Assume that the general fiber (X_b, D_b) has log canonical singularities and that the*

variation of the family is maximal. Then for each $0 < \epsilon \ll 1$ there exists a pair (Z, Δ_ϵ) , an effective divisor Δ on Z , and a morphism $p : Z \rightarrow X$ such that

- (a) $K_Z + \Delta = p^*(K_X + D)$,
- (b) (Z, Δ_ϵ) is klt,
- (c) $g : (Z, \Delta_\epsilon) \rightarrow B$ is a stable family,
- (d) the variation of g is maximal, and
- (e) $\Delta - \Delta_\epsilon$ is an effective divisor such that $\text{Supp}(\epsilon \Delta) \subset \text{Ex}(p) \cap \text{Supp}(p_*^{-1} \Delta)$.

Sketch of proof. The rough idea is to take a \mathbb{Q} -factorial dlt modification of X , and then shrink the resulting divisor so that the new pair $(\tilde{Z}, \tilde{\Delta}_\epsilon)$ is klt. Finally, taking the relative log canonical model of $(\tilde{Z}, \tilde{\Delta}_\epsilon) \rightarrow X$ yields a stable family with klt general fiber and maximal variation. □

We are now in position to prove the main statement of this section, [Proposition 3.1](#), whose proof is inspired by Proposition 2.15 of [\[Patakfalvi and Xu 2015\]](#).

Proof of Proposition 3.1. We begin with a stable family with maximal variation $f : (X, D) \rightarrow B$ such that the generic fiber is log canonical. The goal is to show that $\omega_{X_B^n}(D_n)$ is big for n sufficiently large.

First take $\tilde{p} : \tilde{Z} \rightarrow X$ to be a \mathbb{Q} -factorial dlt modification of X , and let $\tilde{\Delta}$ be a divisor on \tilde{Z} such that $\tilde{p}^*(K_X + D) = K_{\tilde{Z}} + \tilde{\Delta}$. Since \tilde{Z} is \mathbb{Q} -factorial by construction, we can lower the coefficients of the divisor $\tilde{\Delta}$ by $0 < \epsilon \ll 1$, a rational number, to obtain a klt pair $(\tilde{Z}, \tilde{\Delta}_\epsilon)$.

Define $p : Z \rightarrow X$ to be the relative log canonical model of $(\tilde{Z}, \tilde{\Delta}_\epsilon) \rightarrow X$. Denoting the induced morphism by $q : \tilde{Z} \dashrightarrow Z$, we define Δ to be the pushforward $\Delta = q_*(\tilde{\Delta})$. By [Proposition 3.8](#), the new family $g : (Z, \Delta_\epsilon) \rightarrow B$ is a stable family with maximal variation such that the generic fiber is klt. Thus, by [Proposition 3.2](#), for n large enough, $\omega_{Z_B^n}(\Delta_{\epsilon,n})$ is big.

Moreover, since $(Z, \Delta_\epsilon) \rightarrow X$ is the relative log canonical model of $(\tilde{Z}, \tilde{\Delta}_\epsilon) \rightarrow X$, pluri-log canonical forms on \tilde{Z} are the pullbacks of pluri-log canonical forms on Z . From this we conclude that $\omega_{\tilde{Z}_B^n}(\tilde{\Delta}_{\epsilon,n})$ is also big. Now since \tilde{Z} is \mathbb{Q} -factorial, we know that $\epsilon \Delta$ is a \mathbb{Q} -Cartier divisor. This property allows us to enlarge the coefficients of $\tilde{\Delta}$. Recall that $\epsilon \Delta$ is effective by [Proposition 3.8\(e\)](#), and thus $\omega_{\tilde{Z}_B^n}(\tilde{\Delta}_n)$ is big as well.

Since $\tilde{p} : \tilde{Z} \rightarrow X$ is a birational morphism and $\tilde{p}^*(K_X + D) = K_{\tilde{Z}} + \tilde{\Delta}$, pulling back pluri-log canonical forms through \tilde{p} preserves the number of sections. Thus, we finally conclude that $\omega_{X_B^n}(D_n)$ is big. □

Finally, we prove the following theorem for pairs openly of log general type.

Theorem 3.9. *Let $f : (X, D) \rightarrow B$ be a stable family with integral, openly canonical, and log canonical general fiber over a smooth projective variety B . Suppose that*

the variation of the family f is maximal. Then $\omega_{X_{ss}^n}(D_n^{ss})$ is big, where (X_{ss}^n, D_n^{ss}) denotes the n -th fibered power of the weak semistable model of the pair (X, D) .

Proof. Consider the diagram

$$\begin{array}{ccccc}
 (X_{ss}, D^{ss}) & \xrightarrow{\phi} & (\tilde{X}, \tilde{D}) = X \times_{B_1} B & \xrightarrow{\sigma} & (X, D) \\
 \downarrow \pi_{ss} & & \downarrow g & & \downarrow f \\
 \Delta \subset B_1 & \longrightarrow & B_1 & \longrightarrow & B
 \end{array}$$

where $(X_{ss}, D^{ss}) \rightarrow B_1$ denotes the weak semistable model (see Definition 0.4 of [Karu 1999]) of the family $(X, D) \rightarrow B$, and $\Delta \subset B_1$ denotes the discriminant divisor over which the exceptional lies. Such a model exists by [Karu 1999]. Since taking the weak semistable model gives a pair which is at worst openly canonical and log canonical, we are not required to take a resolution of singularities. This is because, by definition of both openly canonical and log canonical singularities, sections of $\omega_{X_{ss}}(D^{ss})$ give regular sections of logarithmic pluricanonical sheaves of any desingularization.

More precisely, we have

$$\phi^*(\omega_g(\tilde{D})) = \omega_{\pi_{ss}}(D^{ss} + E) \subset \omega_{\pi_{ss}}(D^{ss} + \pi_{ss}^*(\Delta)).$$

Let $\pi_{ss}^*\Delta = \Delta^{ss}$. Then since $\omega_g(\tilde{D})$ is big by Theorem 3.3, so is $\omega_g(\tilde{D} - \frac{1}{n}\Delta^{ss})$. Taking fibered powers, as in Proposition 3.1, shows that $\omega_{\tilde{X}_{B_1}^n}(\tilde{D}_n(-\Delta_n^{ss}))$ is also big. Moreover,

$$\phi_n^*(\omega_{\tilde{X}_{B_1}^n}(\tilde{D}_n(-\Delta_n^{ss}))) \subset \omega_{X_{ss}^n}(D_n^{ss})(\Delta_n^{ss} - \Delta_n^{ss}) = \omega_{X_{ss}^n}(D_n^{ss})$$

is big. □

The definition of openly of log general type then implies that we have actually shown the following.

Theorem 3.10. *Let $f : (X, D) \rightarrow B$ be a stable family with integral, openly canonical, and log canonical general fiber over a smooth projective variety B . Suppose that the variation of the family f is maximal. Then there exists an integer $n > 0$ such that (X_B^n, D_n) is openly of log general type.*

4. Singularities

The purpose of this section is to prove that if we begin with a pair (X, D) with log canonical singularities, then fibered powers (X_B^n, D_n) also have log canonical singularities for all $n > 0$. As the following example shows, it is necessary to restrict the singularities, as there exist varieties Y such that ω_Y is big, but Y is not of general type!

Example 4.1. Let Y be the projective cone over a quintic plane curve C . Then ω_Y is big (even ample), but Y is birational to $\mathbb{P}^1 \times C$, which has Kodaira dimension $\kappa(\mathbb{P}^1 \times C) = -\infty$. So although ω_Y is big, Y is *not* openly of log general type.

The following proposition is a version of log inversion of adjunction.

Proposition 4.2 [Patakfalvi 2016, Lemma 2.12]. *The total space of an slc family over an slc base has slc singularities.*

This result immediately extends to products of slc families.

Corollary 4.3. *The total space of the product of slc families over an slc base also has slc singularities.*

Proof. Let $f : (X_1, D_1) \rightarrow B$ and $g : (X_2, D_2) \rightarrow B$ be two slc families over an slc base B . Then the product family $g : (X, \Delta) \rightarrow B$ is the total space of an slc family over either of the factors. Therefore both the product family as well as its total space have slc singularities by [Proposition 4.2](#). \square

Inductively, this shows that the fibered powers (X_B^n, D_n) have semilog canonical singularities. The statement that we will actually use to prove our result is the following:

Proposition 4.4. *Let $f : (X, D) \rightarrow B$ be a stable family with integral and log canonical general fiber over a smooth projective variety B . Then for all $n > 0$, the fibered powers (X_B^n, D_n) have log canonical singularities.*

Proof. By [Proposition 4.2](#), the total space of the family (X, D) is slc. In fact, we will show that it is actually log canonical, which is equivalent to showing that (X, D) is normal. Recall that to show that the pair (X, D) is normal, it suffices to show that it is regular in codimension one (abbreviated R1) and satisfies Serre's condition S2. Since the general fiber has log canonical singularities, the fibers (X_b, D_b) are R1 over the general point of the base B . Over the special fibers, the singularities are of at least codimension one in the fiber, and are thus at least codimension two in the total space. Therefore, it follows that the total space (X, D) is R1. Finally, the pair (X, D) is S2 by definition, since it has semilog canonical singularities.

Therefore, by [Corollary 4.3](#), for all $n > 0$ the fibered powers (X_B^n, D_n) also have log canonical singularities. \square

In fact, the following stronger statements are also true. Although we do not use them in this paper, we hope that they may be of interest to readers.

Proposition 4.5. *The fiber product of two stable families is a stable family.*

Proof. This result essentially follows from Proposition 2.12 in [\[Bhatt et al. 2013\]](#). We reproduce the argument for the convenience of the reader.

Let $f : (X, D) \rightarrow B$ and $g : (Y, E) \rightarrow B$ be two stable families, and denote the fiber product family by $h : (Z, F) \rightarrow B$. Since both families f and g are flat of finite

type with S_2 fibers by assumption, and since we are assuming Kollár’s condition, by Proposition 5.1.4 of [Abramovich and Hassett 2011] we have that $\omega_{X/B}^{[k]}(D)$ is flat over B . Moreover, by Lemma 2.11 of [Bhatt et al. 2013] we have that

$$p_X^* \omega_{X/B}^{[k]}(D) \otimes p_Y^* \omega_{Y/B}^{[k]}(E)$$

is a reflexive sheaf on the product. By Lemma 2.6 of [Hassett and Kovács 2004], the above sheaf is isomorphic to $\omega_{Z/B}^{[k]}(F)$ on an open subset whose complement has codimension at least two, and therefore we conclude that

$$\omega_{Z/B}^{[k]}(F) = p_X^* \omega_{X/B}^{[k]}(D) \otimes p_Y^* \omega_{Y/B}^{[k]}(E).$$

Moreover, Kollár’s condition holds, as by assumption both components of this fiber product commute with arbitrary base change. Choosing a sufficient index k , namely the least common multiple of the index of the factors, we see that $\omega_{Z/B}(F)$ is a relatively ample \mathbb{Q} -line bundle, and thus we conclude that $h : (Z, F) \rightarrow B$ is also a stable family. □

Proposition 4.6. *The total space of the fiber product of stable families over a stable base is stable.*

Proof. By Proposition 2.15 in [Patakfalvi and Xu 2015] (see also [Fujino 2012, Theorem 1.13]), if $f : (X, D) \rightarrow (B, E)$ is a stable family whose variation is maximal over a normal base, then $\omega_f(D)$ is nef. First we note that it suffices to prove the statement over a normal base, since nef is a property which is decided on curves. Since normalization is a finite birational morphism, nonnegative intersection with a curve is preserved. Thus, we wish to show that this statement is true without the assumption that the variation of f is maximal. Let $B' \rightarrow B$ be a finite cover of the base so that the pullback family $f' : (X', D') \rightarrow B'$ maps to $g : (\mathcal{U}, \mathcal{D}) \rightarrow T$, a family of maximal variation. In this case $\omega_{f'}(D')$ is nef, as it is the pullback of $\omega_g(\mathcal{D})$ which is nef. Since $\omega_{f'}(D')$ is the pullback of $\omega_f(D)$ by the finite morphism $X' \rightarrow X$, the projection formula implies that $\omega_f(D)$ is nef as well. This shows that the sheaf $\omega_f(D)$ is nef, regardless of whether the variation of f is maximal or not. Then since $\omega_f(D)$ is nef and f -ample, and since the base is stable, $\omega_B(E)$ is ample. Therefore, we can conclude that $\omega_X(D + f^*E) = \omega_f(D) \otimes f^*\omega_B(E)$ is ample. □

The next theorem, which we actually need, follows from Propositions 3.1 and 4.4.

Theorem 4.7. *Let $(X, D) \rightarrow B$ be a stable family with integral and log canonical general fiber and maximal variation over a smooth projective variety B . Then there exists an integer $n > 0$ such that the pair (X_B^n, D_n) is of log general type.*

Proof. By Proposition 3.1, we have that $\omega_{X_B^n}(D_n)$ is big, and by Proposition 4.4, the fibered powers (X_B^n, D_n) have log canonical singularities. □

To prove the stronger [Theorem 4.12](#), we must show that what we have proven also works after taking the quotient by a group of automorphisms. This is precisely the content of [Proposition 4.8](#) and [Corollary 4.11](#) below.

This claim essentially follows from the work of various authors in previous papers in the subject. The approach is present in, for example, Lemma 3.2.4 of [[Abramovich and Matsuki 2001](#)] as well as Lemma 2.4 of [[Pacelli 1999](#)]. We reproduce the statement in our case below.

Proposition 4.8. *Let (X, D) be openly of log general type. There exists a positive integer n such that the pair $(X_B^n, D_n)/G$ is also openly of log general type.*

Proof. Let $H \subset X$ be the locus of fixed points of the action of $G \subseteq \text{Aut}(X, D)$. Let \mathcal{I}_H denote the corresponding sheaf of ideals. We have seen before that $\omega_f(D)$ is big. Then, for sufficiently large k , we have that the sheaf

$$\omega_f(D)^{\otimes k} \otimes f^* \omega_B^{\otimes k} \otimes \mathcal{I}_H^{|G|}$$

is big. If we pass to the k -th fibered power, we have that

$$(\omega_{X_B^k}(D_k))^{\otimes k} \otimes f_k^* \omega_B^{\otimes k} \otimes \prod_{i=1}^k \pi_i^{-1} \mathcal{I}_H^{|G|}$$

is also big.

Regarding the above product, we have $\prod_{i=1}^k \pi_i^{-1} \mathcal{I}_H^{|G|} \subset (\sum_{i=1}^k \pi_i^{-1} \mathcal{I}_H^{|G|})^k$, and the latter ideal vanishes to order at least $k|G|$ on the fixed points of the action of G . Moreover, we have that

$$(\omega_{f_k}(D_k))^{\otimes k} \otimes \pi_k^* \omega_B^{\otimes k} = (\omega_{X_B^k}(D_k))^{\otimes k}.$$

This allows us to conclude that for $n \gg 0$, there are enough invariant sections of $\omega_{X_B^k}(D_k)^{\otimes n}$ vanishing on the fixed point locus to order at least $n|G|$.

Now let

$$r : (\mathcal{X}, \mathcal{D}) \rightarrow (X_B^k, D_k)$$

be an equivariant good resolution of singularities such that $r^{-1}(D_k) = \mathcal{D}$. Note that such a resolution is guaranteed by Hironaka [[1977](#)]. Since $X \setminus D$ does not necessarily have canonical singularities away from the general fiber, we have introduced exceptional divisors in the resolution that will alter sections of $\omega_X(D)$. To fix this, we simply apply the methods used in the proof of [Theorem 3.9](#) — namely, twist by some small negative multiple of the divisor Δ containing the exceptional.

To conclude the result, it suffices to show that invariant sections of $(\omega_{X_B^k}(D_k))^{\otimes n}$ vanishing on the fixed point locus to order at least $n|G|$ descend to sections of the pluri-log canonical divisors of a good resolution of the quotient pair $(X_B^n/G, D_n/G)$.

Denote by $q : (\mathcal{X}, \mathcal{D}) \rightarrow (\mathcal{X}/G, \mathcal{D}/G)$ the morphism to the quotient, and let

$$\phi : (\tilde{\mathcal{X}}/G, \tilde{\mathcal{D}}/G) \rightarrow (\mathcal{X}/G, \mathcal{D}/G)$$

denote a good resolution. Then Lemma 4 from [Abramovich 1997b] tells us that the invariant sections of $\omega_{\mathcal{X}}(D)^{\otimes n}$ vanishing on the fixed point locus to order $\geq n|G|$ come from sections of the pluri-log canonical divisors of a desingularization, i.e., sections of $\omega_{\tilde{\mathcal{X}}}(\tilde{D})^{\otimes n}$. Therefore, for n sufficiently large, the quotient pair $(X_B^n, D_n)/G$ is openly of log general type. \square

This also proves the following theorem:

Theorem 4.9. *Let $f : (X, D) \rightarrow B$ be a stable family with integral, openly canonical, and log canonical general fiber over a smooth projective variety B . Suppose that the variation of the family f is maximal. Let G be a finite group such that $(X, D) \rightarrow B$ is G -equivariant. Then there exists an integer $n > 0$ such that the quotient $(X_B^n/G, D_n/G)$ is openly of log general type.*

Furthermore, combining Proposition 4.8 with Proposition 4.4 yields:

Corollary 4.10. *Let $f : (X, D) \rightarrow B$ be an slc family with integral and log canonical general fiber over a smooth projective variety B . Then for n large enough, the quotient pair $(X_B^n/G, D_n/G)$ also has log canonical singularities.*

This then gives an analogue to Proposition 4.8 for pairs of log general type.

Corollary 4.11. *Let (X, D) be a pair of log general type. There exists a positive integer n such that the pair $(X_B^n, D_n)/G$ is also a pair of log general type.*

Thus we have completed the proof of the following theorem.

Theorem 4.12. *Let $(X, D) \rightarrow B$ be a stable family with integral and log canonical general fiber over a smooth projective variety B . Suppose that the variation of the family f is maximal (see Definition 2.9). Let G be a finite group such that $(X, D) \rightarrow B$ is G -equivariant. Then there exists an integer $n > 0$ such that the quotient $(X_B^n/G, D_n/G)$ of the pair by a finite group of automorphisms is of log general type.*

Proof. This follows from Theorem 4.7 and Corollary 4.11. \square

The next and final section shows how to reduce the proof of the Theorem 1.1 to Theorem 4.12. Then, we show that Theorem 1.2 follows from Theorem 1.1.

5. Proof of Theorems 1.1 and 1.2 — reduction to the case of max variation

The final section of this paper is devoted to reducing the proofs of our two main theorems to the case of maximal variation. We will use the existence of a tautological family over a finite cover of our moduli space to show that, after a birational modification of the base, the pullback of a stable family with integral and log canonical general fiber has a morphism to the quotient of a family of maximal

variation by a finite group. Then using the fact that our result holds for families of maximal variation, we will conclude that, after a modification of the base, a high fibered power of the pullback of a stable family with integral and log canonical general fiber has a morphism to a pair of log general type.

Finally, we show that if we add the assumption that the general fiber of our family is openly canonical and log canonical, we can avoid taking a modification of the base to prove [Theorem 1.2](#).

Remark 5.1. As we will be using the moduli space of stable pairs \overline{M}_h , we remind the reader that we are in the situation of [Assumption 2.8](#).

Unfortunately the moduli space \overline{M}_h that we are working with does *not* carry a universal family. The following lemma gives a *tautological family*, which can be thought of as an approximation of a universal family.

Lemma 5.2 [[Kovács and Patakfalvi 2015](#), Corollary 5.19]. *There exists a tautological family $(\mathcal{T}, \mathcal{D})$ over a finite cover Ω of the moduli space \overline{M}_h of stable log pairs. That is, there exists a variety Ω , a finite surjective map $\phi : \Omega \rightarrow \overline{M}_h$, and a stable family $\mathcal{T} \rightarrow \Omega$ such that $\phi(x) = [(\mathcal{T}_x, \mathcal{D}_x)]$.*

Proposition 5.3. *Let $f : (X, D) \rightarrow B$ be a stable family such that the general fiber is integral and has log canonical singularities. Then there exists a birational modification of the base $\tilde{B} \rightarrow B$, and a morphism $(\tilde{X}, \tilde{D}) \rightarrow \tilde{B}$ to $(\mathcal{T}_{\tilde{\Sigma}}, \tilde{\mathcal{D}})/G$, the quotient of a family of maximal variation by a finite group G*

Proof. Let $f : (X, D) \rightarrow B$ be a stable family such that the general fiber is integral and has log canonical singularities. In particular, we do *not* assume that the variation of f is maximal. There is a well defined canonical morphism $B \rightarrow \overline{M}_h$. Call the image of this morphism Σ . Over this Σ lies the universal family $(\mathcal{T}_{\Sigma}, \mathcal{D})$. Since \overline{M}_h is a stack, the maps $(X, D) \rightarrow (\mathcal{T}_{\Sigma}, \mathcal{D})$ and $B \rightarrow \Sigma$ factor through the coarse spaces $\underline{\Sigma}$ and $(\underline{\mathcal{T}}_{\Sigma}, \underline{\mathcal{D}})$. The general fiber of $(\underline{\mathcal{T}}_{\Sigma}, \underline{\mathcal{D}}) \rightarrow \underline{\Sigma}$ is simply $(S, D_S)/K$, where (S, D_S) is a pair of log general type and K is the finite automorphism group.

Unfortunately there is no control on the singularities of Σ — if the singularities are not too mild, the fibered powers $(\mathcal{T}_{\Sigma}^n, \mathcal{D}_n)$ have no chance of having log canonical singularities. To remedy this we take a resolution of singularities. Using [Lemma 5.2](#), we take a Galois cover followed by an equivariant resolution of singularities to obtain $\tilde{\Sigma} \rightarrow \underline{\Sigma}$. Call the Galois group of this cover H . Then over $\tilde{\Sigma}$, we have a tautological family $(\mathcal{T}_{\tilde{\Sigma}}, \tilde{\mathcal{D}})$. Here the general fiber is simply (S, D_S) , a pair of log general type.

Consider the quotient map $\tilde{\Sigma} \rightarrow \tilde{\Sigma}/H$. Taking the pullback of $(\mathcal{T}_{\Sigma}, \underline{\mathcal{D}})$ through $\tilde{\Sigma}/H$ yields $(\mathcal{T}_{\tilde{\Sigma}/H}, \tilde{\mathcal{D}}')$. Letting G be the group $G = H \times K$, we can construct the following diagram:

$$\begin{array}{ccccccccc}
 (\mathcal{T}_{\tilde{\Sigma}}, \tilde{\mathcal{D}}) & \longrightarrow & (\mathcal{T}_{\tilde{\Sigma}}, \tilde{\mathcal{D}})/G & \xrightarrow{\nu} & (\mathcal{T}_{\tilde{\Sigma}/H}, \tilde{\mathcal{D}}') & \longrightarrow & (\mathcal{T}_{\Sigma}, \underline{\mathcal{D}}) & \longrightarrow & \mathcal{T} \\
 \downarrow & & \downarrow & & \downarrow & & \downarrow & & \downarrow \\
 \tilde{\Sigma} & \longrightarrow & \tilde{\Sigma}/H & \longrightarrow & \tilde{\Sigma}/H & \longrightarrow & \underline{\Sigma} & \longrightarrow & \overline{M}_h
 \end{array}$$

We claim that the map $\nu : (\mathcal{T}_{\tilde{\Sigma}}, \tilde{\mathcal{D}})/G \rightarrow (\mathcal{T}_{\tilde{\Sigma}/H}, \tilde{\mathcal{D}}')$ is actually the normalization of $(\mathcal{T}_{\tilde{\Sigma}/H}, \tilde{\mathcal{D}}')$. First note that $(\mathcal{T}_{\tilde{\Sigma}}, \tilde{\mathcal{D}})/G$ is normal, and that the morphism ν is finite as the morphism $(\mathcal{T}_{\tilde{\Sigma}}, \tilde{\mathcal{D}}) \rightarrow (\mathcal{T}_{\Sigma}, \underline{\mathcal{D}})$ is. Therefore, to prove ν is the normalization of $(\mathcal{T}_{\tilde{\Sigma}/H}, \tilde{\mathcal{D}}')$, it suffices to prove that ν is birational. To do so, consider the following diagram:

$$\begin{array}{ccccccc}
 (\mathcal{T}_{\tilde{\Sigma}}, \tilde{\mathcal{D}}) & \longrightarrow & (\mathcal{T}_{\tilde{\Sigma}}, \tilde{\mathcal{D}})/H & \longrightarrow & ((\mathcal{T}_{\tilde{\Sigma}}, \tilde{\mathcal{D}})/H)/K = (\mathcal{T}_{\tilde{\Sigma}}, \tilde{\mathcal{D}})/G \\
 \downarrow & & \downarrow & & \downarrow \\
 \tilde{\Sigma} & \longrightarrow & \tilde{\Sigma}/H & \longrightarrow & \tilde{\Sigma}/H
 \end{array}$$

From this diagram it is clear that the general fiber of $(\mathcal{T}_{\tilde{\Sigma}}, \tilde{\mathcal{D}})/G \rightarrow \tilde{\Sigma}/H$ is precisely $(S, D_S)/K$ — the quotient by H identifies fibers and the quotient by K removes the automorphisms. Since the map ν is an isomorphism over the generic fibers, ν is a birational map and thus is the normalization of $(\mathcal{T}_{\tilde{\Sigma}/H}, \tilde{\mathcal{D}}')$.

The pair (X, D) does *not* map to $(\mathcal{T}_{\tilde{\Sigma}/H}, \tilde{\mathcal{D}}')$. Instead, take a modification of the base $\tilde{B} \rightarrow B$, where $\tilde{B} = B \times_{\Sigma} \tilde{\Sigma}/H$. Then the pullback (\tilde{X}, \tilde{D}) maps to $(\mathcal{T}_{\tilde{\Sigma}/H}, \tilde{\mathcal{D}}')$. Since (\tilde{X}, \tilde{D}) is normal and ν is the normalization, we see that (\tilde{X}, \tilde{D}) also maps to $(\mathcal{T}_{\tilde{\Sigma}}, \tilde{\mathcal{D}})/G$. Finally, because the family $(\mathcal{T}_{\tilde{\Sigma}}, \tilde{\mathcal{D}})/G \rightarrow \tilde{\Sigma}/H$ is the quotient of a family of maximal variation by a finite group, we have completed the proof of the proposition. \square

Proof of Theorem 1.1. Let $(\mathcal{T}_{\tilde{\Sigma}}, \tilde{\mathcal{D}})$ denote the tautological family of maximal variation obtained in the proof of Proposition 5.3. Passing to n -th fibered powers, Theorem 4.12 guarantees that $(\mathcal{T}_{\tilde{\Sigma}}^n, \tilde{\mathcal{D}}_n)$ is of log general type. By Corollary 4.11, $(\mathcal{T}_{\tilde{\Sigma}}^n, \tilde{\mathcal{D}}_n)/G$ is also of log general type for n sufficiently large. Thus the proof of Theorem 1.1 follows from Proposition 5.3, as we have shown that after modifying the base, we obtain a morphism from a high fibered power of our family to a pair of log general type. \square

Finally, we prove Theorem 1.2, the fibered power theorem for pairs openly of log general type.

Proof of Theorem 1.2. The proof essentially follows from the proof of Proposition 5.3. Assuming that the general fiber is openly canonical and log canonical, Theorem 4.9 shows that, for n sufficiently large, the pair $(\mathcal{T}_{\tilde{\Sigma}}^n, \tilde{\mathcal{D}}_n)/G$ is openly of log general type. As there is a birational morphism $(\mathcal{T}_{\tilde{\Sigma}}^n, \tilde{\mathcal{D}}_n)/G \rightarrow (\mathcal{I}_{\Sigma}^n, \underline{\mathcal{D}}_n)$, it follows that $(\mathcal{I}_{\Sigma}^n, \underline{\mathcal{D}}_n)$

is also openly of log general type. Therefore, we have constructed a morphism from a high fibered power of our family to a pair openly of log general type, and have thus completed the proof of the theorem. The upshot here is that we do not have to modify the base of our starting family. \square

Acknowledgements

We thank Brendan Hassett for suggesting this problem. We thank Dan Abramovich for his constant support and many useful conversations. K. Ascher thanks Dori Bejleri and Patricio Gallardo for many helpful conversations, as well as Sándor Kovács and Zsolt Patakfalvi for discussing their results with him at length. We also thank them for providing us with an early draft of [Kovács and Patakfalvi 2015]. Ascher thanks the Mathematics department at Chalmers University for providing an excellent working environment. Finally, we thank the referee for their helpful suggestions which improved the exposition of this paper.

References

- [Abramovich 1997a] D. Abramovich, “A high fibered power of a family of varieties of general type dominates a variety of general type”, *Invent. Math.* **128**:3 (1997), 481–494. [MR](#) [Zbl](#)
- [Abramovich 1997b] D. Abramovich, “Uniformity of stably integral points on elliptic curves”, *Invent. Math.* **127**:2 (1997), 307–317. [MR](#) [Zbl](#)
- [Abramovich and Hassett 2011] D. Abramovich and B. Hassett, “Stable varieties with a twist”, pp. 1–38 in *Classification of algebraic varieties*, European Mathematical Society, Zürich, 2011. [MR](#) [Zbl](#)
- [Abramovich and Matsuki 2001] D. Abramovich and K. Matsuki, “Uniformity of stably integral points on principally polarized abelian varieties of dimension ≤ 2 ”, *Israel J. Math.* **121** (2001), 351–380. [MR](#) [Zbl](#)
- [Abramovich and Voloch 1996] D. Abramovich and J. F. Voloch, “Lang’s conjectures, fibered powers, and uniformity”, *New York J. Math.* **2** (1996), 20–34, electronic. [MR](#) [Zbl](#)
- [Bhatt et al. 2013] B. Bhatt, W. Ho, Z. Patakfalvi, and C. Schnell, “Moduli of products of stable varieties”, *Compos. Math.* **149**:12 (2013), 2036–2070. [MR](#) [Zbl](#)
- [Caporaso et al. 1997] L. Caporaso, J. Harris, and B. Mazur, “Uniformity of rational points”, *J. Amer. Math. Soc.* **10**:1 (1997), 1–35. [MR](#) [Zbl](#)
- [Fujino 2012] O. Fujino, “Semipositivity theorems for moduli problems”, preprint, 2012. [arXiv](#)
- [Hartshorne 1980] R. Hartshorne, “Stable reflexive sheaves”, *Math. Ann.* **254**:2 (1980), 121–176. [MR](#) [Zbl](#)
- [Hassett 1996] B. Hassett, “Correlation for surfaces of general type”, *Duke Math. J.* **85**:1 (1996), 95–107. [MR](#) [Zbl](#)
- [Hassett and Kovács 2004] B. Hassett and S. J. Kovács, “Reflexive pull-backs and base extension”, *J. Algebraic Geom.* **13**:2 (2004), 233–247. [MR](#) [Zbl](#)
- [Hironaka 1977] H. Hironaka, “Idealistic exponents of singularity”, pp. 52–125 in *Algebraic geometry* (J. J. Sylvester Symposium (1976)), edited by J.-I. Igusa, Johns Hopkins University Press, Baltimore, MD, 1977. [MR](#) [Zbl](#)

- [Karu 1999] K. Karu, *Semistable reduction in characteristic 0*, Ph.D. thesis, Boston University, 1999, available at <http://search.proquest.com/docview/304512245/>.
- [Kollár 2010] J. Kollár, “[Book on moduli of surfaces](#)”, book in progress, 2010, available at <https://web.math.princeton.edu/~kollar/>.
- [Kollár 2013] J. Kollár, *Singularities of the minimal model program*, Cambridge Tracts in Mathematics **200**, Cambridge University Press, 2013. [MR](#) [Zbl](#)
- [Kollár and Kovács 2010] J. Kollár and S. J. Kovács, “[Log canonical singularities are Du Bois](#)”, *J. Amer. Math. Soc.* **23**:3 (2010), 791–813. [MR](#) [Zbl](#)
- [Kollár and Mori 1998] J. Kollár and S. Mori, *Birational geometry of algebraic varieties*, Cambridge Tracts in Mathematics **134**, Cambridge University Press, 1998. [MR](#) [Zbl](#)
- [Kovács and Patakfalvi 2015] S. J. Kovács and Z. Patakfalvi, “[Projectivity of the moduli space of stable log-varieties and subadditivity of log-Kodaira dimension](#)”, preprint, 2015. [arXiv](#)
- [Pacelli 1997] P. L. Pacelli, “[Uniform boundedness for rational points](#)”, *Duke Math. J.* **88**:1 (1997), 77–102. [MR](#) [Zbl](#)
- [Pacelli 1999] P. L. Pacelli, “[Uniform bounds for stably integral points on elliptic curves](#)”, *Proc. Amer. Math. Soc.* **127**:9 (1999), 2535–2546. [MR](#) [Zbl](#)
- [Patakfalvi 2016] Z. Patakfalvi, “[Fibered stable varieties](#)”, *Trans. Amer. Math. Soc.* **368**:3 (2016), 1837–1869. [MR](#) [Zbl](#)
- [Patakfalvi and Xu 2015] Z. Patakfalvi and C. Xu, “[Ampleness of the CM line bundle on the moduli space of canonically polarized varieties](#)”, preprint, 2015. [arXiv](#)

Communicated by János Kollár

Received 2016-03-01

Revised 2016-06-30

Accepted 2016-07-31

kenascher@math.brown.edu

*Mathematics Department, Brown University,
151 Thayer Street, Providence, RI 02912, United States*

tamos@chalmers.se

*Mathematical Sciences, Chalmers University of Technology,
Chalmers Tvärgata 3, SE-412 96 Gothenburg, Sweden*

Guidelines for Authors

Authors may submit manuscripts in PDF format on-line at the Submission page at the [ANT website](#).

Originality. Submission of a manuscript acknowledges that the manuscript is original and is not, in whole or in part, published or under consideration for publication elsewhere. It is understood also that the manuscript will not be submitted elsewhere while under consideration for publication in this journal.

Language. Articles in *ANT* are usually in English, but articles written in other languages are welcome.

Length There is no a priori limit on the length of an *ANT* article, but *ANT* considers long articles only if the significance-to-length ratio is appropriate. Very long manuscripts might be more suitable elsewhere as a memoir instead of a journal article.

Required items. A brief abstract of about 150 words or less must be included. It should be self-contained and not make any reference to the bibliography. If the article is not in English, two versions of the abstract must be included, one in the language of the article and one in English. Also required are keywords and subject classifications for the article, and, for each author, postal address, affiliation (if appropriate), and email address.

Format. Authors are encouraged to use \LaTeX but submissions in other varieties of \TeX , and exceptionally in other formats, are acceptable. Initial uploads should be in PDF format; after the refereeing process we will ask you to submit all source material.

References. Bibliographical references should be complete, including article titles and page ranges. All references in the bibliography should be cited in the text. The use of Bib \TeX is preferred but not required. Tags will be converted to the house format, however, for submission you may use the format of your choice. Links will be provided to all literature with known web locations and authors are encouraged to provide their own links in addition to those supplied in the editorial process.

Figures. Figures must be of publication quality. After acceptance, you will need to submit the original source files in vector graphics format for all diagrams in your manuscript: vector EPS or vector PDF files are the most useful.

Most drawing and graphing packages (Mathematica, Adobe Illustrator, Corel Draw, MATLAB, etc.) allow the user to save files in one of these formats. Make sure that what you are saving is vector graphics and not a bitmap. If you need help, please write to graphics@msp.org with details about how your graphics were generated.

White space. Forced line breaks or page breaks should not be inserted in the document. There is no point in your trying to optimize line and page breaks in the original manuscript. The manuscript will be reformatted to use the journal's preferred fonts and layout.

Proofs. Page proofs will be made available to authors (or to the designated corresponding author) at a Web site in PDF format. Failure to acknowledge the receipt of proofs or to return corrections within the requested deadline may cause publication to be postponed.

Algebra & Number Theory

Volume 10 No. 7 2016

Arithmetic invariant theory and 2-descent for plane quartic curves	1373
JACK A. THORNE	
Furstenberg sets and Furstenberg schemes over finite fields	1415
JORDAN S. ELLENBERG and DANIEL ERMAN	
Local deformation rings for GL_2 and a Breuil–Mézard conjecture when $l \neq p$	1437
JACK SHOTTON	
Generalized Kuga–Satake theory and rigid local systems, II: rigid Hecke eigensheaves	1477
STEFAN PATRIKIS	
Lifting preprojective algebras to orders and categorifying partial flag varieties	1527
LAURENT DEMONET and OSAMU IYAMA	
A fibered power theorem for pairs of log general type	1581
KENNETH ASCHER and AMOS TURCHET	