

*Pacific  
Journal of  
Mathematics*

Volume 324 No. 1

May 2023

# PACIFIC JOURNAL OF MATHEMATICS

Founded in 1951 by E. F. Beckenbach (1906–1982) and F. Wolf (1904–1989)

[msp.org/pjm](http://msp.org/pjm)

## EDITORS

Don Blasius (Managing Editor)  
Department of Mathematics  
University of California  
Los Angeles, CA 90095-1555  
[blasius@math.ucla.edu](mailto:blasius@math.ucla.edu)

Matthias Aschenbrenner  
Fakultät für Mathematik  
Universität Wien  
Vienna, Austria  
[matthias.aschenbrenner@univie.ac.at](mailto:matthias.aschenbrenner@univie.ac.at)

Paul Balmer  
Department of Mathematics  
University of California  
Los Angeles, CA 90095-1555  
[balmer@math.ucla.edu](mailto:balmer@math.ucla.edu)

Vyjayanthi Chari  
Department of Mathematics  
University of California  
Riverside, CA 92521-0135  
[chari@math.ucr.edu](mailto:chari@math.ucr.edu)

Robert Lipshitz  
Department of Mathematics  
University of Oregon  
Eugene, OR 97403  
[lipshitz@uoregon.edu](mailto:lipshitz@uoregon.edu)

Kefeng Liu  
Department of Mathematics  
University of California  
Los Angeles, CA 90095-1555  
[liu@math.ucla.edu](mailto:liu@math.ucla.edu)

Sorin Popa  
Department of Mathematics  
University of California  
Los Angeles, CA 90095-1555  
[popa@math.ucla.edu](mailto:popa@math.ucla.edu)

Paul Yang  
Department of Mathematics  
Princeton University  
Princeton NJ 08544-1000  
[yang@math.princeton.edu](mailto:yang@math.princeton.edu)

## PRODUCTION

Silvio Levy, Scientific Editor, [production@msp.org](mailto:production@msp.org)

---

See inside back cover or [msp.org/pjm](http://msp.org/pjm) for submission instructions.

---

The subscription price for 2023 is US \$605/year for the electronic version, and \$820/year for print and electronic. Subscriptions, requests for back issues and changes of subscriber address should be sent to Pacific Journal of Mathematics, P.O. Box 4163, Berkeley, CA 94704-0163, U.S.A. The Pacific Journal of Mathematics is indexed by [Mathematical Reviews](#), [Zentralblatt MATH](#), [PASCAL CNRS Index](#), [Referativnyi Zhurnal](#), [Current Mathematical Publications](#) and [Web of Knowledge \(Science Citation Index\)](#).

---

The Pacific Journal of Mathematics (ISSN 1945-5844 electronic, 0030-8730 printed) at the University of California, c/o Department of Mathematics, 798 Evans Hall #3840, Berkeley, CA 94720-3840, is published twelve times a year. Periodical rate postage paid at Berkeley, CA 94704, and additional mailing offices. POSTMASTER: send address changes to Pacific Journal of Mathematics, P.O. Box 4163, Berkeley, CA 94704-0163.

---

PJM peer review and production are managed by EditFLOW<sup>®</sup> from Mathematical Sciences Publishers.

PUBLISHED BY

 **mathematical sciences publishers**  
nonprofit scientific publishing

<http://msp.org/>

© 2023 Mathematical Sciences Publishers

# SPIKE SOLUTIONS FOR A FRACTIONAL ELLIPTIC EQUATION IN A COMPACT RIEMANNIAN MANIFOLD

IMENE BENDAHOU, ZIED KHEMIRI AND FETHI MAHMOUDI

Given an  $n$ -dimensional compact Riemannian manifold  $(M, g)$  without boundary, we consider the nonlocal equation

$$\varepsilon^{2s} P_g^s u + u = u^p \quad \text{in } (M, g),$$

where  $P_g^s$  stands for the fractional Paneitz operator with principal symbol  $(-\Delta_g)^s$ ,  $s \in (0, 1)$ ,  $p \in (1, 2_s^* - 1)$  with  $2_s^* := \frac{2n}{n-2s}$ ,  $n > 2s$ , represents the critical Sobolev exponent and  $\varepsilon > 0$  is a small real parameter. We construct a family of positive solutions  $u_\varepsilon$  that concentrate, as  $\varepsilon \rightarrow 0$  goes to zero, near critical points of the mean curvature  $H$  for  $0 < s < \frac{1}{2}$  and near critical points of a reduced function involving the scalar curvature of the manifold  $M$  for  $\frac{1}{2} \leq s < 1$ .

1. Introduction and preliminary results	1
2. Setting-up of the problem	8
3. The finite-dimensional reduction	14
4. Asymptotic expansion of the finite-dimensional functional	20
Appendix: Proof of Lemma 2.7	41
References	45

## 1. Introduction and preliminary results

Let  $s \in (0, 1)$  and let  $(M, g)$  be an  $n$ -dimensional smooth compact Riemannian manifold without boundary with  $n > 2s$ . We consider the nonlocal problem

$$(1-1) \quad \varepsilon^{2s} P_g^s u + u = u^p, \quad u > 0 \text{ in } (M, g),$$

where  $P_g^s$  is the fractional Paneitz operator whose principal symbol is exactly  $(-\Delta_g)^s$ ,  $p \in (1, 2_s^* - 1)$  with  $2_s^* := \frac{2n}{n-2s}$  is the critical Sobolev exponent and  $\varepsilon > 0$  is a small real parameter. In this paper we study concentration phenomena of solutions to problem (1-1) as the parameter  $\varepsilon$  goes to zero. We prove that such solutions exist

*MSC2020:* primary 35R11; secondary 35B33, 35B44, 58J05.

*Keywords:* fractional Laplacian, fractional nonlinear Schrödinger equation, Lyapunov–Schmidt reduction, concentration phenomena.

and concentration occur near critical points of the mean curvature  $H$  for  $0 < s < \frac{1}{2}$  and near critical points of a reduced function involving the scalar curvature of the manifold  $M$  for  $\frac{1}{2} \leq s < 1$ .

In the local setting (i.e.,  $s = 1$ ), an analogue-type result has been obtained by Micheletti and Pistoia [32]. They considered the following problem:

$$(1-2) \quad -\varepsilon^2 \Delta_g u + u = u^p, \quad u > 0 \text{ in } (M, g),$$

where  $(M, g)$  is a smooth compact Riemannian manifold of dimension  $n \geq 2$ ,  $\Delta_g$  is the Laplace–Beltrami operator on  $M$ ,  $p > 1$  for  $n = 2$  and

$$1 < p < 2^* - 1 = \frac{n+2}{n-2} \quad \text{for } n \geq 3.$$

They constructed a family of positive solutions which concentrate, for sufficiently small values of  $\varepsilon$ , near stable critical points of the scalar curvature  $S_g$  of the metric  $g$ . Precisely, if  $J_\varepsilon$  is the energy functional defined by

$$J_\varepsilon(u) = \frac{1}{\varepsilon^n} \int_M \left[ |\nabla_g u|^2 + \frac{1}{2} u^2 - \frac{1}{p+1} u^{p+1} \right] d\mu_g,$$

they proved that the following asymptotic expansion holds:

$$(1-3) \quad J_\varepsilon(u_\varepsilon) = c_0 - c_1 \varepsilon^2 S_g(\xi) + o(\varepsilon^2),$$

where  $c_0$  and  $c_1$  are explicit constants. Since any critical point of  $J_\varepsilon$  is a solution to problem (1-2), it turns out that is the scalar curvature function which is relevant for point concentration in  $M$  for problem (1-2). On the other hand, consider the following local singular perturbed Neumann problem:

$$(1-4) \quad -\varepsilon^2 \Delta u + u = u^p, \quad u > 0 \text{ in } \Omega, \quad \frac{\partial u}{\partial \nu} = 0 \text{ on } \partial\Omega,$$

on a smooth bounded domain  $\Omega$  in  $\mathbb{R}^n$ , where  $\varepsilon$  is a small parameter,  $\nu$  denotes the outward normal to  $\partial\Omega$ , and the exponent  $p > 1$ . Lin, Ni and Takagi [30; 33; 34] proved that equation (1-4) possesses a least-energy solution  $u_\varepsilon$  which concentrate near maximum points of the mean curvature  $H$  of  $\partial\Omega$  for  $\varepsilon$  sufficiently small. As above, the proof is based on an asymptotic expansion of the associated energy functional. They showed that

$$(1-5) \quad J_\varepsilon(u_\varepsilon) = \frac{1}{2} I(w) - c\varepsilon H(\xi) + o(\varepsilon),$$

where  $c > 0$  is an explicit constant,  $w$  is the unique ground state solution of

$$\begin{cases} \Delta w - w + w^p = 0, & w > 0 \text{ in } \mathbb{R}^n, \\ w(0) = \max_{y \in \mathbb{R}^n} w(y), \\ \lim_{|y| \rightarrow +\infty} w(y) = 0, \end{cases}$$

and  $I[w]$  is the ground-state energy

$$I[w] = \frac{1}{2} \int_{\mathbb{R}^n} |\nabla w|^2 dy + \frac{1}{2} \int_{\mathbb{R}^n} w^2 dy - \frac{1}{p+1} \int_{\mathbb{R}^n} w^{p+1} dy.$$

This time it turns out that the mean curvature of the boundary of  $\Omega$  is relevant for point concentration of problem (1-4).

The main objective of this paper is to extend the previous results to the nonlocal setting. Before stating our main results we introduce some preliminary notations and definitions, we refer to [5; 6; 8; 20; 26] for more precise details.

Given an  $n$ -dimensional smooth compact Riemannian manifold  $M = M^n$  without boundary, with  $n \geq 2$  and let  $X = X^{n+1}$  be a smooth  $(n+1)$ -dimensional manifold whose boundary is  $M^n$ . A function  $\rho$  is said to be a defining function of the boundary  $M^n$  in  $X^{n+1}$  if

$$(1-6) \quad \rho > 0 \text{ in } X^{n+1}, \quad \rho = 0 \text{ on } M^n \quad \text{and} \quad d\rho \neq 0 \text{ on } M^n.$$

We say that  $g^+$  is conformally compact if, there exists a defining function  $\rho$ , such that the setting  $\bar{g} = \rho^2 g^+$ , the closure  $(\bar{X}^{n+1}, \bar{g})$  is compact. This induces a conformal class of metrics  $g = \bar{g}|_{TM^n}$  on  $M^n$  as defining functions vary. The conformal manifold  $(M^n, [g])$  is called the conformal infinity of  $(X^{n+1}, g^+)$ .

A metric  $g^+$  is said to be asymptotically hyperbolic if it is conformally compact and the sectional curvature approaches  $-1$  at infinity.

Given a conformally compact, asymptotically hyperbolic manifold  $(X^{n+1}, g^+)$  and a representative  $g$  in  $[g]$  on the conformal infinity  $M$ , there is a uniquely defining function  $\rho$  such that, on  $M \times (0, \delta)$  in  $(X, g^+)$ , has the normal form

$$g^+ = \rho^{-2}(d\rho^2 + g_\rho),$$

where  $g_\rho$  is a one-parameter family of metrics on  $M$  satisfying  $g_{\rho_M} = g$ . Moreover,  $g_\rho$  has an asymptotic expansion which contains only even powers of  $\rho$ , at least up to degree  $n$ . It is well known (see Mazzeo and Melrose [31], Graham and Zworski [27]) that, given  $f \in C^\infty(M)$  and  $z \in \mathbb{C}$ , the eigenvalue problem

$$(1-7) \quad -\Delta_{g^+} v - z(n-z)v = 0 \quad \text{in } X$$

has a solution of the form

$$(1-8) \quad v = F\rho^{n-z} + G\rho^z, \quad F, G \in C^\infty(X) \quad \text{and} \quad F|_{\rho=0} = f$$

for all  $z \in \mathbb{C}$  unless  $z(n-z)$  belongs to the pure point spectrum of  $-\Delta_{g^+}$ . Now, the scattering operator on  $M$  is defined by

$$(1-9) \quad S(z)f := G|_M,$$

which is a meromorphic family of pseudodifferential operator in  $\{z \in \mathbb{C}; \operatorname{Re}(z) > \frac{n}{2}\}$ .

We define the conformally covariant fractional powers of the Laplacian by

$$(1-10) \quad P_g^s = P^s[g^+, g] := \begin{cases} \frac{-2^{2s}\Gamma(s)}{\Gamma(1-s)} S\left(\frac{n}{2} + s\right) & \text{if } s \notin \mathbb{N}, \\ (-1)^s 2^{2s} s! (s-1) \operatorname{Res}_{z=\frac{n}{2}+s} S(z) & \text{for } s \in \mathbb{N}, \end{cases}$$

whose principal symbol is exactly  $(-\Delta_g)^s$ . Here  $\operatorname{Res}_{z=s_0} S(z)$  is the residue at  $s_0$  of  $S$ .

Notice that if  $(X, g^+)$  is Poincaré–Einstein, we have for  $s = 1$

$$P_g^1 u = -\Delta_g u + \frac{n-2}{4(n-1)} R_g(u),$$

which is nothing but the usual conformal Laplacian, and for  $s = 2$  we have

$$P_g^2 u = (-\Delta_g)^2 u - \operatorname{div}_g((c_1 R_g - c_2 \operatorname{Ric}_g) du) + \frac{n-4}{2} Q_g u,$$

which is nothing but the Paneitz operator.

The operator  $P_g^s = P^s[g^+, g]$  satisfy an important conformal covariance property (see [8] and [27]). Indeed, for a conformal change of metric

$$g_v := v^{4/(n-2s)} g, \quad v > 0,$$

we have that

$$P^s[g^+, g_v] \phi = v^{-(n+2s)/(n-2s)} P^s[g^+, g](v\phi)$$

for all smooth functions  $\phi$  defined on  $M$ .

Finally, we define the fractional scalar curvature  $Q_g^s$  associated to the conformal fractional Laplacian  $P_g^s$  by

$$(1-11) \quad Q_g^s := P_g^s(1).$$

According to [8], it is natural to consider the following degenerate equation with the weighted Neumann boundary condition:

$$(1-12) \quad \begin{cases} -\operatorname{div}(\rho^{1-2s} \nabla U) + E(\rho) U = 0 & \text{in } (X, \bar{g}), \\ \partial_\nu^s U = 0 & \text{on } (M, g), \end{cases}$$

where  $\bar{g} := \rho^2 g^+$  is a compact metric on the closure  $\bar{X}$  of  $X$ ,  $g$  its restriction onto  $M$  ( $g = \bar{g}|_M$ ) and

$$E(\rho) := \rho^{-1-z} (-\Delta_{g^+} - z(n-z)) \rho^{n-z},$$

with  $2z := n + 2s$  and

$$(1-13) \quad \partial_\nu^s U := -\kappa_s \lim_{\rho \rightarrow 0} \rho^{1-2s} \frac{\partial U}{\partial \rho},$$

where  $\nu$  is the outward normal vector to  $M = \partial X$  and

$$(1-14) \quad \kappa_s := \frac{\Gamma(s)}{2^{1-2s}\Gamma(1-s)}.$$

Let  $\text{Ext}^s(u)$  be the  $s$ -harmonic extension of  $u$  and denote it by  $U$ . Chang and González [8] proved that the generalized eigenvalue problem (1-7) on a noncompact manifold  $(X^{n+1}, g^+)$  is equivalent to a linear degenerate elliptic problem on the compact manifold  $(\bar{X}^{n+1}, \bar{g})$  for  $\bar{g} = \rho^2 g^+$ . Moreover, they identify the fractional Laplacian defined above with the normalized scattering operators and the one given in the spirit of the Dirichlet-to-Neumann operator by Caffarelli and Silvestre in [6]. Precisely, they proved the following result, which will play a crucial role in this paper and provides an alternative way to study problem (1-1).

**Proposition 1.1** [8, Theorems 4.3 and 5.1]. *Let  $(X^{n+1}, g^+)$  be a asymptotically hyperbolic manifold with the conformal infinity  $(M^n, [g])$  and  $\rho$  the geodesic defining function of  $g$ . Assume also that the trace  $H$  of the second fundamental form  $\pi_{ij} = -\langle \nabla_{\partial_\rho} \partial_i, \partial_j \rangle_g$  on  $M = \partial X$  vanishes if  $s \in (\frac{1}{2}, 1)$ . For a smooth function  $u$  on  $M$ , if  $v$  is a solution of (1-7) and satisfies (1-8), then the function  $U := \rho^{z-n} v$  solves*

$$(1-15) \quad -\text{div}(\rho^{1-2s} \nabla U) + E(\rho)U = 0 \quad \text{in } (X, \bar{g}) \quad \text{and} \quad U = u \quad \text{on } (M, g),$$

where  $\bar{g} := \rho^2 g^+$ ,  $E(\rho) := \rho^{-1-z}(-\Delta_{g^+} - z(n-z))\rho^{n-z}$ , and  $2z := n + 2s$ . Moreover,

$$(1-16) \quad P_g^s(u) = \begin{cases} \partial_\nu^s U & \text{for } s \in (0, 1) \setminus \{\frac{1}{2}\}, \\ \partial_\nu^s U + \frac{n-1}{2n} H u & \text{for } s = \frac{1}{2}. \end{cases}$$

Here the operator  $\partial_\nu^s U$  denotes the weighted normal derivative defined in (1-13).

For  $r_0 > 0$  sufficiently small, it also holds that

$$(1-17) \quad E(\rho) = \frac{n-2s}{4n} [R_{\bar{g}} \rho^{1-2s} - (R_{g^+} + n(n+1))\rho^{-1-2s}] \quad \text{on } M \times (0, r_0).$$

Notice that the transformation law of the scalar curvature (see (1.1) in [20] and (2.3) in [28]) implies that

$$(1-18) \quad R_{g^+} = -n(n+1) + n\rho \partial_\rho \log(\det g(\rho)) + \rho^2 R_{\bar{g}} \quad \text{on } M \times (0, r_0),$$

then, using the fact that

$$(1-19) \quad \partial_\rho \log(\det g(\rho))|_{\rho=0} = \text{Tr}(g(\rho)^{-1} \partial_\rho g(\rho))|_{\rho=0} = -2H,$$

the term  $E(\rho)$  in (1-17) becomes

$$\begin{aligned}
 (1-20) \quad E(\rho)(z) &= -\left(\frac{n-2s}{4}\right) \partial_\rho \log(\det g(\rho))(\sigma) \rho^{-2s} \\
 &= -\left(\frac{n-2s}{4}\right) \partial_\rho \log(\det g(\rho))|_{\rho=0}(\sigma) \rho^{-2s} + \mathcal{O}(\rho^{1-2s}) \\
 &= \left(\frac{n-2s}{2}\right) H(\sigma) \rho^{-2s} + \mathcal{O}(\rho^{1-2s})
 \end{aligned}$$

for all  $z = (\sigma, \rho) \in M \times (0, r_0)$ .

Observe that (1-18) yields

$$R_{g^+} + n(n+1) = o(1)$$

near  $M$  for all asymptotically hyperbolic manifolds, where  $o(1)$  is a quantity which goes to 0 uniformly as  $\rho \rightarrow 0$ . We assume that for  $\frac{1}{2} \leq s < 1$ , the scalar curvature  $R_{g^+}$  in  $X$  satisfies the following decay assumption

$$(1-21) \quad R_{g^+} + n(n+1) = o(\rho^2) \quad \text{as } \rho \rightarrow 0 \text{ uniformly on } M.$$

Assumption (1-21) naturally appears to control extrinsic quantities such as the mean curvature  $H$  or the second fundamental form  $\pi$  on  $M$ , on the other hand, it is an intrinsic curvature condition of an asymptotically hyperbolic manifold, which is independent of the choice of a representative of the class  $[g]$ . Consequently, we have immediately from (1-21) (see, for instance, [11, Lemma 3.2]) that

$$(1-22) \quad H = 0 \quad \text{and} \quad R_{\rho\rho}[\bar{g}] = \frac{1-2n}{2(n-1)} \|\pi\|_g^2 + \frac{1}{2(n-1)} R[g].$$

Before stating our main result, we define on  $M$

$$(1-23) \quad \Xi(\xi) := \frac{1}{6}(\tilde{d} + \tilde{d}_1 \tilde{C}_{n,s}^2) R_g(\xi) + \frac{1}{6} \tilde{d}_1 \tilde{C}_{n,s}^3 \|\pi\|^2(\xi),$$

where the constants  $\tilde{d}$ ,  $\tilde{d}_1$ ,  $\tilde{C}_{n,s}^2$  and  $\tilde{C}_{n,s}^3$  will be defined later in (4-7), (4-8) and (4-19) respectively. Our main theorem reads as:

**Theorem 1.2.** *Let  $(X^{n+1}, g^+)$  be an asymptotically hyperbolic manifold with the conformal infinity  $(M^n, [g])$  such that  $M = \partial X$ . Assume that  $n > 2s + 2$  and let  $H$  be the trace of the second fundamental form of  $(M, g)$ . Then there exists  $\varepsilon_0 > 0$  such that for any  $\varepsilon \in (0, \varepsilon_0)$ , problem (1-1) has a solution  $u_\varepsilon$  which concentrates at a point  $\xi \in M$  as  $\varepsilon$  goes to zero, where  $\xi$  is a critical point of  $H$  for  $0 < s < \frac{1}{2}$ , and is a critical point of the function  $\Xi$  defined in (1-23), for  $\frac{1}{2} \leq s < 1$  provided that (1-21) holds.*



Observe that, solving our main equation (1-1) is equivalent to finding a positive solution  $U$  to the problem

$$(1-24) \quad \begin{cases} -\operatorname{div}(\rho^{1-2s}\nabla U) + E(\rho)U = 0 & \text{in } (X, \bar{g}), \\ \varepsilon^{2s}\partial_\nu^s U = u^p - u & \text{on } (M, g), \\ U|_M = u. \end{cases}$$

Up to a scaling in the second equation in the above problem (1-24), we are led to study the following nonlocal equation

$$(1-25) \quad (-\Delta_{g_\varepsilon})^s v + v = v^p, \quad v > 0 \text{ in } (M_\varepsilon, g_\varepsilon),$$

where  $M_\varepsilon = \frac{1}{\varepsilon}M$  endowed with the scaled metric  $g_\varepsilon = \frac{1}{\varepsilon^2}g$ . For  $\varepsilon > 0$  sufficiently small, we will construct an approximate solution to our problem whose leading term is a solution of the limit equation

$$(1-26) \quad (-\Delta)^s u + u = u^p, \quad u > 0 \text{ in } H^s(\mathbb{R}^n).$$

Precisely, we will look for a solution  $u_\varepsilon$  to problem (1-1) that concentrate at interior points  $\xi$  of the manifold  $M$  which, at main order, looks like

$$(1-27) \quad u_\varepsilon(x) \approx \omega\left(\frac{x-\xi}{\varepsilon}\right),$$

where  $\omega$  is the solution of the limit problem (1-26).

We recall that, for  $s \in (0, 1)$ , the fractional Laplacian operator  $(-\Delta)^s$  is defined at any point  $x \in \mathbb{R}^n$  by

$$(1-28) \quad (-\Delta)^s u(x) = c_{n,s} \int_{\mathbb{R}^n} \frac{2u(x) - u(x+y) - u(x-y)}{|y|^{n+2s}} dy,$$

where  $c_{n,s}$  is an explicit positive normalizing constant and  $H^s(\mathbb{R}^n)$  is the fractional Sobolev space of order  $s$  on  $\mathbb{R}^n$ , defined by

$$(1-29) \quad H^s(\mathbb{R}^n) := \left\{ u \in L^2(\mathbb{R}^n) : \int_{\mathbb{R}^n} \int_{\mathbb{R}^n} \frac{|u(x) - u(y)|^2}{|x - y|^{n+2s}} dx dy < \infty \right\},$$

endowed with the norm

$$(1-30) \quad \|u\|_{H^s(\mathbb{R}^n)} := \left( \int_{\mathbb{R}^n} |u(x)|^2 dx + \int_{\mathbb{R}^n} \int_{\mathbb{R}^n} \frac{|u(x) - u(y)|^2}{|x - y|^{n+2s}} dx dy \right)^{1/2}.$$

We refer to [18; 29; 40] for an introduction to the fractional Laplacian operator.

Concentration phenomenon for related nonlocal PDEs in the euclidean space have attracted lot of attention. For example, if we consider the fractional Schrödinger equation

$$(1-31) \quad (-\Delta)^s u + V(x)u = f(x, u) \quad \text{in } \mathbb{R}^n$$

under suitable conditions on the potential  $V$  and the nonlinearity  $f$ , existence and multiplicity results of spike layer solutions have been obtained (see, for instance, Alves and Miyagaki [1], Alves, de Lima and Nóbrega [2], Autuori and Pucci [3], Felmer, Quaas and Tan [22], Cheng [12], Secchi [35], Dávila, del Pino and Wei [16], Dipierro, Palatucci and Valdinoci [19], Fall, Mahmoudi and Valdinoci [21], Bisci and Rădulescu [4], Servadei and Valdinoci [36; 37], Shang and Zhang [38; 39], Caponi and Pucci [7], Fiscella, Pucci and Saldi [23]). See also [9; 10; 36].

Some results have also been obtained for the fractional nonlinear Schrödinger (NLS) equation in bounded domains under Dirichlet and Neumann boundary conditions. We mention the result of Dávila et al. [17] who built a family of solutions that concentrate at an interior point of the domain for a fractional NLS with zero Dirichlet datum. The Neumann fractional NLS have been considered in [41]. See also [13] where concentration phenomena for a perturbed fractional Yamabe problem has been considered.

The rest of the paper is organized as follows. In [Section 2](#), we first give some properties of the limit profile and the linearized operator around it. Then, we give the asymptotic expansion of the metric and we prove some preliminary results. Finally, we construct the first ansatz of the approximate solution and its decay properties. [Section 3](#) is devoted to the finite dimensional reduction procedure. In [Section 4](#), we prove our main result using the asymptotic expansions of the finite dimensional problem obtained in [Sections 4A](#) and [4B](#). Finally, in [Appendix](#), we prove [Lemma 2.7](#).

## 2. Setting-up of the problem

**2A. Uniqueness and nondegeneracy for the limit equation.** In this subsection, we recall some known results for the limit equation (1-26). Frank, Lenzmann and Silvestre [25] proved uniqueness and nondegeneracy of ground state solutions for (1-26) in arbitrary dimension  $n \geq 1$  and any admissible exponent  $1 < p < \frac{n+2s}{n-2s}$ . We summarize the results of [24] and [25] in the following lemmas.

**Lemma 2.1.** *Let  $n \geq 1$ ,  $s \in (0, 1)$  and  $p \in (1, \frac{n+2s}{n-2s})$ . Then there exists a unique solution (up to translation)  $\omega \in H^s(\mathbb{R}^n)$  of (1-26). Moreover,  $\omega$  is radial, positive, strictly decreasing in  $|x|$  and satisfies*

$$(2-1) \quad \frac{C_1}{1 + |x|^{n+2s}} \leq \omega(x) \leq \frac{C_2}{1 + |x|^{n+2s}} \quad \text{for } x \in \mathbb{R}^n,$$

with some constants  $C_2 \geq C_1 > 0$ .

**Lemma 2.2.** *Let  $n \geq 1$ ,  $s \in (0, 1)$  and  $p \in (1, \frac{n+2s}{n-2s})$ . Suppose that  $\omega$  is the solution of the limit problem (1-26). Then the linearized operator*

$$L_0(\phi) := (-\Delta)^s \phi + \phi - p\omega^{p-1}\phi$$

is nondegenerate. That is, its kernel is given by

$$(2-2) \quad \ker L_0 = \text{Span}\{\partial_{x_1}\omega, \dots, \partial_{x_n}\omega\}.$$

The nondegeneracy implies that 0 is an isolated spectral point of  $L_0$ . More precisely, for all  $\phi \in (\ker L_0)^\perp$ , one has

$$(2-3) \quad \|L_0(\phi)\|_{L^2(\mathbb{R}^n)} \geq c\|\phi\|_{H^{2s}(\mathbb{R}^n)}$$

for some positive constant  $c$ . By Lemma C.2 of [25], it holds that, for  $j = 1, \dots, n$ ,  $\partial_{x_j}\omega$  has the decay estimate

$$(2-4) \quad |\partial_{x_j}\omega| \leq \frac{C}{1 + |x|^{n+2s}}.$$

It is well known that when  $s = 1$ , the ground state solution of (1-26) decays exponentially at infinity. However, when  $s \in (0, 1)$ , the corresponding ground bound state solution decays polynomially like  $\frac{1}{|x|^{n+2s}}$  when  $|x| \rightarrow \infty$ .

Let  $W$  denote the  $s$ -harmonic extension of  $\omega$  to  $\mathbb{R}_+^{n+1}$ , that is,  $W$  satisfies

$$(2-5) \quad \begin{cases} \operatorname{div}(t^{1-2s}\nabla W) = 0 & \text{in } \mathbb{R}_+^{n+1}, \\ \partial_\nu^s W = \omega^p - \omega & \text{on } \mathbb{R}^n, \\ W = \omega & \text{on } \mathbb{R}^n. \end{cases}$$

Next, we define for all  $i = 1, \dots, n$

$$(2-6) \quad z_i(x) := \partial_{x_i}\omega(x), \quad x \in \mathbb{R}^n$$

and we set  $Z_i(x, t) = \text{Ext}^s(z_i(x))$ , the  $s$ -harmonic extension of  $z_i$ . It has been proven in [15] that any bounded solution on  $\mathbb{R}^n \times \{0\}$  of the linearized equation

$$(2-7) \quad \begin{cases} \operatorname{div}(t^{1-2s}\nabla\Phi) = 0 & \text{in } \mathbb{R}_+^{n+1}, \\ \partial_\nu^s\Phi = p\omega^{p-1}\Phi - \Phi & \text{on } \mathbb{R}^n \end{cases}$$

is a linear combination of  $Z_i$ .

**2B. Preliminary results.** We first give the asymptotic expansion of the metric of an asymptotically hyperbolic manifold  $X$  near its boundary  $M$ . Next, we introduce the functional setting and we give the first ansatz of the approximate solution and its decay properties.

*Asymptotic expansion of the metric  $\bar{g}$  near the boundary.* Let  $(X, g^+)$  be an asymptotically hyperbolic manifold with boundary  $(M, g)$  and let  $\rho$  be the geodesic defining function, so that  $(\bar{X}, \bar{g})$  is a compact manifold where  $\bar{g} = \rho^2 g^+$ . Assume  $0 \in M$  and let  $x = (x_1, \dots, x_n) \in \mathbb{R}^n$  be normal coordinates on  $M$  at 0 and

$$(x, x_{n+1}) \in \mathbb{R}^n \times (0, +\infty)$$

be the Fermi coordinates on  $X$  at 0. We set  $N = n + 1$  and

$$(2-8) \quad \bar{g} = dx_N^2 + g_{ij}(x, x_N) dx_i dx_j,$$

so that  $\bar{g}|_M = g$ . Here the indices  $i, j$  run from 1 to  $n$  and summations over repeated indices is understood. We have the following asymptotic expansion of the metric  $\bar{g}$  near 0, see Lemmas 3.1 and 3.2 in [20] and Lemma 2.2 in [28]. Precisely, we have:

**Lemma 2.3.** *For  $(x_1, \dots, x_n) \in \mathbb{R}^n$  and  $x_N = x_{n+1} > 0$  small, it holds that*

$$(2-9) \quad g^{ij} = \bar{g}^{ij} = \delta_{ij} + 2\pi_{ij}x_N + \frac{1}{3}R_{ikjl}x_k x_l + 2\pi_{ij,k}x_k x_N \\ + (3\pi_{ih}\pi_{hj}R_{iNjN})x_N^2 + \mathcal{O}(|(x, x_N)|^3)$$

and

$$(2-10) \quad \det \bar{g} = \det g = 1 - 2Hx_N + (H^2 - \|\pi\|^2 - R_{NN})x_N^2 - 2H_{,k}x_k x_N \\ - \frac{1}{3}R_{kl}x_k x_l + \mathcal{O}(|(x, x_N)|^3),$$

$$(2-11) \quad \sqrt{\det \bar{g}} = \sqrt{\det g} = 1 - Hx_N + \frac{1}{2}(H^2 - \|\pi\|^2 - R_{NN})x_N^2 - H_{,k}x_k x_N \\ - \frac{1}{6}R_{kl}x_k x_l + \mathcal{O}(|(x, x_N)|^3).$$

Here  $\pi$  stands for the second fundamental form of  $M = \partial X$ ,  $H$  is its trace,  $R_{ij}$  are the components of the Ricci tensor,  $R_{ijkl}$  are the components of the Riemannian tensor and  $R_{NN} = \bar{g}^{ij}R_{iNjN}$ . The indices  $i, j, k$ , and  $l$  run from 1 to  $n$ , summations over repeated indices is understood and every tensors are computed at 0.

*The functional setting.* We define the space  $H(X, \rho^{1-2s})$  to be the weighted Sobolev space endowed with the inner product

$$(2-12) \quad \langle U, V \rangle_\varepsilon := \frac{1}{\varepsilon^{n-2s}} \int_X \rho^{1-2s} [(\nabla U, \nabla V)_{\bar{g}} + UV] d\text{vol}_{\bar{g}}$$

and the corresponding norm

$$(2-13) \quad \|U\|_\varepsilon = \left( \frac{1}{\varepsilon^{n-2s}} \int_X \rho^{1-2s} [|\nabla U|_{\bar{g}}^2 + U^2] d\text{vol}_{\bar{g}} \right)^{1/2}.$$

Let  $L_\varepsilon^q$  be the Banach space  $L^q(M)$  equipped the norm

$$(2-14) \quad |U|_{q,\varepsilon} := \left( \frac{1}{\varepsilon^n} \int_M |U|^q d\text{vol}_g \right)^{1/q}.$$

It is clear that for any  $1 \leq q < \frac{2n}{n-2s}$ , the embedding of  $H^1(X, \rho^{1-2s})$  in  $L^q(M)$  is continuous and compact. Particularly, there exists a constant  $c = c(s, n, X)$  such that

$$(2-15) \quad |U|_{q,\varepsilon} \leq c \|U\|_\varepsilon.$$

The next lemmas provide equivalent norms to the  $\|\cdot\|_\varepsilon$ -norm.

**Lemma 2.4.** *The norm*

$$(2-16) \quad \|U\|_{\varepsilon,*} := \left( \frac{1}{\varepsilon^{n-2s}} \int_X \rho^{1-2s} |\nabla U|_{\bar{g}}^2 d\text{vol}_{\bar{g}} + \frac{1}{\varepsilon^n} \int_M U^2 d\text{vol}_g \right)^{1/2}$$

is equivalent to the norm  $\|\cdot\|_\varepsilon$  defined in (2-13).

**Lemma 2.5.** *Assume that the mean curvature  $H$  on  $M = \partial X$  vanishes for  $s \in [\frac{1}{2}, 1)$  (which is the case when (1-21) holds) and there exists a constant  $C > 0$  such that the coercivity assumption*

$$(2-17) \quad \frac{1}{\varepsilon^{n-2s}} \left( \int_X \rho^{1-2s} |\nabla U|_{\bar{g}}^2 + E(\rho) U^2 \right) d\text{vol}_{\bar{g}} + \frac{1}{\varepsilon^n} \int_M U^2 d\text{vol}_g \geq \frac{C}{\varepsilon^{n-2s}} \int_X \rho^{1-2s} U^2 d\text{vol}_{\bar{g}}$$

holds for arbitrary function  $U \in H^1(X, \rho^{1-2s})$ . Then the norm

$$\|U\|_{\varepsilon,**} := \left( \frac{1}{\varepsilon^{n-2s}} \kappa_s \int_X (\rho^{1-2s} |\nabla U|_{\bar{g}}^2 + E(\rho) U^2) d\text{vol}_{\bar{g}} + \frac{1}{\varepsilon^n} \int_M U^2 d\text{vol}_g \right)^{1/2}$$

is an equivalent norm to  $\|\cdot\|_\varepsilon$ .

*Proof.* For the proof of the previous lemmas, we refer the reader to Lemmas 3.1 and 3.2 in [13].  $\square$

We next define the trace operator

$$(2-18) \quad i : H^1(X, \rho^{1-2s}) \rightarrow L^p(M)$$

by  $i(U) = U|_M := u$ . The operator  $i$  is well defined, continuous and, compact for  $1 \leq p < \frac{2n}{n-2s}$ . The adjoint operator  $i^* : L^{p'} \rightarrow H^1(X, \rho^{1-2s})$ , where  $\frac{1}{p'} = \frac{1}{p} + \frac{2s}{n}$ , is a continuous map defined by the equation

$$(2-19) \quad \begin{cases} -\text{div}(t^{1-2s} \nabla U) + E(\rho) U = 0 & \text{in } (X, \bar{g}), \\ \varepsilon^{2s} \partial_\nu^s U = v - u & \text{on } (M, g), \\ U = u & \text{on } (M, g), \end{cases}$$

where  $U = i^*(v)$  is bounded thanks to Lemma 2.5. The above properties are proved in [13]. We summarize them in the next lemma.

**Lemma 2.6** [13, Lemma 3.3 and Corollary 3.4]. *Assume  $n > 2s$  and  $p \in (1, \frac{n+2s}{n-2s})$ . Then the embedding  $i : H^1(X, \rho^{1-2s}) \hookrightarrow L^p(M)$  is compact continuous map. The adjoint operator  $i^* : L^{p'} \rightarrow H^1(X, \rho^{1-2s})$ , where  $p'$  satisfying  $\frac{1}{p'} = \frac{1}{p} - \frac{2s}{n}$ , is a continuous map. In other words, if  $v \in L^{p'}(M)$  such that  $U = i^*(v)$  and  $u = i(U)$ , then there exists  $C = C(p) > 0$  such that*

$$(2-20) \quad \|u\|_{L^p(M)} \leq C \|v\|_{L^{p'}(M)}.$$

Furthermore, for  $n > 2s$  and for any fixed  $q \in (1, \frac{n+2s}{n-2s})$ , the adjoint map  $i^* : L^q(M) \rightarrow H^1(X, \rho^{1-2s})$  is compact.

By Lemma 2.6, we can rewrite problem (1-24) in the equivalent way

$$(2-21) \quad U = i^*(f(u)) \text{ and } U = u > 0 \text{ on } M$$

for  $U \in H^1(X, \rho^{1-2s})$  and  $f(u) := u^p$ .

*Decay properties of approximate solutions.* Recall that we want to find a solution  $U$  to the problem

$$(2-22) \quad \begin{cases} -\operatorname{div}(\rho^{1-2s} \nabla U) + E(\rho)U = 0 & \text{in } (X, \bar{g}), \\ \varepsilon^{2s} \partial_\nu^s U = u^p - u & \text{on } (M, g). \end{cases}$$

Let  $r_0$  be a small positive real number be as in (1-17), we choose  $r < r_0$  a positive number less than quarter of the injectivity radius of  $(M, g)$ . We define  $\chi_r$  to be a smooth cut-off function such that  $\chi_r = 1$  in  $(0, r)$  and 0 in  $(2r, \infty)$ . Observe that, any point  $z \in X$  near the boundary  $M$  can be described as  $z = (\hat{\xi}, \rho)$  for some  $\hat{\xi} \in M$  and  $\rho \in (0, \infty)$ .

Let  $W(\cdot, \cdot)$  be the  $s$ -harmonic extension of  $\omega$ , solution of the limit problem (1-26) and define the scaled function  $W_\varepsilon$  ( $\varepsilon > 0$ ) by

$$(2-23) \quad W_\varepsilon(x, x_N) := W\left(\frac{x}{\varepsilon}, \frac{x_N}{\varepsilon}\right), \quad x \in \mathbb{R}^n, \quad x_N > 0.$$

Fix a point  $\xi \in M$ , we define the functions  $\mathcal{W}_{\varepsilon, \xi}$  on  $X$  by

$$(2-24) \quad \mathcal{W}_{\varepsilon, \xi}(z) = \mathcal{W}_{\varepsilon, \xi}(\hat{\xi}, \rho) = \begin{cases} \chi_r(d(z, \xi)) W_\varepsilon(\exp_\xi^{-1}(\hat{\xi}), \rho) & \text{if } d(z, \xi) < 2r, \\ 0, & \text{otherwise,} \end{cases}$$

where  $\exp$  is the exponential map on  $(M, g)$  and  $d(\cdot, \xi)$  is the function defined near the boundary of  $(X, \bar{g})$  by

$$d(z, \xi)^2 = d((\hat{\xi}, \rho), \xi)^2 = d_M(\hat{\xi}, \xi)^2 + \rho^2,$$

where  $d_M(\cdot, \xi)$  is the geodesic distance from  $\xi$  on  $(M, g)$ .

We look for a solution of problem (1-24) of the form

$$(2-25) \quad U = \mathcal{W}_{\varepsilon, \xi} + \Phi,$$

where  $\Phi$  is a function defined on  $X$  whose  $H^1(X, \rho^{1-2s})$ -norm is sufficiently small and  $\mathcal{W}_{\varepsilon, \xi}$  is the global approximation given in (2-24). Now, for  $\xi \in M$ ,  $\varepsilon > 0$  and  $i = 1, \dots, n$ , we introduce the functions

$$(2-26) \quad \mathcal{Z}_{\varepsilon, \xi}^i(z) = \mathcal{Z}_{\varepsilon, \xi}^i(\hat{\xi}, \rho) = \begin{cases} \chi_r(d(z, \xi)) Z_\varepsilon^i(\exp_\xi^{-1}(\hat{\xi}), \rho) & \text{if } d(z, \xi) < 2r, \\ 0, & \text{otherwise,} \end{cases}$$

where  $Z_\varepsilon^i$ ,  $i = 1, \dots, n$ , are defined by

$$(2-27) \quad Z_\varepsilon^i(x, x_N) := Z_i\left(\frac{x}{\varepsilon}, \frac{x_N}{\varepsilon}\right),$$

with  $Z_i = \text{Ext}^s(z_i)$ , the  $s$ -harmonic extension of the functions  $z_i$  defined in (2-6).

Next, we introduce the subspace

$$(2-28) \quad K_{\varepsilon, \xi} := \text{Span}\{Z_{\varepsilon, \xi}^1, \dots, Z_{\varepsilon, \xi}^n\}$$

and we let  $K_{\varepsilon, \xi}^\perp$  be its orthogonal complement with respect to the inner product  $\langle \cdot, \cdot \rangle_{\varepsilon, **}$ , that is,

$$(2-29) \quad K_{\varepsilon, \xi}^\perp := \{U \in H^1(X, \rho^{1-2s}) : \langle Z_{\varepsilon, \xi}^i, U \rangle_{\varepsilon, **} = 0 \text{ for all } i = 1, \dots, n\}.$$

Furthermore, denote by

$$(2-30) \quad \Pi_{\varepsilon, \xi} : H^1(X, \rho^{1-2s}) \rightarrow K_{\varepsilon, \xi} \quad \text{and} \quad \Pi_{\varepsilon, \xi}^\perp : H^1(X, \rho^{1-2s}) \rightarrow K_{\varepsilon, \xi}^\perp$$

the orthogonal projections onto  $K_{\varepsilon, \xi}$  and  $K_{\varepsilon, \xi}^\perp$  respectively.

The function  $U = \mathcal{W}_{\varepsilon, \xi} + \Phi$  is a solution of (1-24) if and only if  $\Phi$  solves

$$(2-31) \quad \Pi_{\varepsilon, \xi}^\perp \{ \mathcal{W}_{\varepsilon, \xi} + \Phi - i^*(i(f(\mathcal{W}_{\varepsilon, \xi} + \Phi))) \} = 0,$$

$$(2-32) \quad \Pi_{\varepsilon, \xi} \{ \mathcal{W}_{\varepsilon, \xi} + \Phi - i^*(i(f(\mathcal{W}_{\varepsilon, \xi} + \Phi))) \} = 0.$$

We end this section by the following result which concerns the decay property of  $W_\varepsilon$  and the functions  $Z_\varepsilon^i$  defined in (2-26). We postpone its proof to [Appendix](#).

**Lemma 2.7.** *Assume that  $n \geq 2$ , fix any  $0 < R_1 < R_2$  and set  $A_{(R_1, R_2)}^+ := B_{R_2}^+ \setminus B_{R_1}^+$ . Then as  $\varepsilon \rightarrow 0$  the following estimates hold true:*

$$(2-33) \quad \int_{\mathbb{R}_+^{n+1} \setminus B_{R_1}^+} x_N^{1-2s} |\nabla W_\varepsilon|^2 dx dx_N = \mathcal{O}(\varepsilon^{2n-4s}),$$

$$(2-34) \quad \int_{B_{R_1}^+} x_N^{1-2s} |\nabla W_\varepsilon|^2 dx dx_N = \begin{cases} \mathcal{O}(\varepsilon^{n+1-2s}) & \text{for } n > 2s + 1, \\ \mathcal{O}(\varepsilon^2 |\ln \varepsilon|) & \text{for } n = 2s + 1, \\ \mathcal{O}(\varepsilon^{2n-4s}) & \text{for } n < 2s + 1, \end{cases}$$

$$(2-35) \quad \int_{A_{(R_1, R_2)}^+} x_N^{1-2s} W_\varepsilon^2 dx dx_N = \begin{cases} \mathcal{O}(\varepsilon^{2n-4s}) & \text{for } n \neq 2s + 2, \\ \mathcal{O}(\varepsilon^4 |\ln \varepsilon|) & \text{for } n = 2s + 2. \end{cases}$$

Moreover, we have

$$(2-36) \quad \int_{\mathbb{R}_+^{n+1} \setminus B_{R_1}^+} x_N^{1-2s} |\nabla Z_\varepsilon^i|^2 dx dx_N = \mathcal{O}(\varepsilon^{2n-4s}) \quad \text{for } i = 1, \dots, n.$$

$$(2-37) \quad \int_{A_{(R_1, R_2)}^+} x_N^{1-2s} (Z_\varepsilon^i)^2 dx dx_N = \mathcal{O}(\varepsilon^{2n-4s}) \quad \text{for } i = 1, \dots, n,$$

and

$$(2-38) \quad \int_{B_{R_1}^+} x_N^{1-2s} \mathcal{O}(|(x, x_N)|^2) |\nabla W_\varepsilon|^2 dx dx_N = \begin{cases} \mathcal{O}(\varepsilon^{n+2-2s}) & \text{for } n > 2s + 2, \\ \mathcal{O}(\varepsilon^4 |\ln \varepsilon|) & \text{for } n = 2s + 2, \\ \mathcal{O}(\varepsilon^{2n-4s}) & \text{for } n < 2s + 2. \end{cases}$$

### 3. The finite-dimensional reduction

In this section we will solve (2-31). Let us introduce the linear operator

$$L_{\varepsilon, \xi} : (K_{\varepsilon, \xi})^\perp \rightarrow (K_{\varepsilon, \xi})^\perp$$

defined by

$$(3-1) \quad L_{\varepsilon, \xi}(\Phi) := \Pi_{\varepsilon, \xi}^\perp (\Phi - i^*(i(f'(\mathcal{W}_{\varepsilon, \xi})\Phi))), \quad \Phi \in (K_{\varepsilon, \xi})^\perp.$$

Clearly, equation (2-31) is equivalent to

$$(3-2) \quad L_{\varepsilon, \xi}(\Phi) = N_{\varepsilon, \xi}(\Phi) + R_{\varepsilon, \xi},$$

where

$$(3-3) \quad R_{\varepsilon, \xi} := \Pi_{\varepsilon, \xi}^\perp [i^*(i(f(\mathcal{W}_{\varepsilon, \xi}))) - \mathcal{W}_{\varepsilon, \xi}],$$

$$(3-4) \quad N_{\varepsilon, \xi}(\Phi) := \Pi_{\varepsilon, \xi}^\perp [i^*(i(f(\mathcal{W}_{\varepsilon, \xi} + \Phi) - f(\mathcal{W}_{\varepsilon, \xi}) - f'(\mathcal{W}_{\varepsilon, \xi})\Phi))].$$

Our first task is to study the invertibility of  $L_{\varepsilon, \xi}$ . This is given by the next lemma.

**Lemma 3.1.** *Suppose that  $n > 2s$ . Then, there exists  $\varepsilon_0 > 0$  and  $c > 0$  such that for any  $\xi \in M$  and for any  $\varepsilon \in (0, \varepsilon_0)$*

$$(3-5) \quad \|L_{\varepsilon, \xi}(\Phi)\|_{\varepsilon, **} \geq c \|\Phi\|_{\varepsilon, **}$$

for all  $\Phi \in (K_{\varepsilon, \xi})^\perp$ .

*Proof.* The proof is based on classical blow up argument. We argue by contradiction, assuming that there exist sequences  $\varepsilon_m \rightarrow 0$ ,  $\xi_m \in M$  such that  $\xi_m \rightarrow \xi$ ,  $\Phi_m \in K_{\varepsilon_m, \xi_m}^\perp$ , with  $\|\Phi_m\|_{\varepsilon_m, **} = 1$  such that

$$(3-6) \quad L_{\varepsilon_m, \xi_m}(\Phi_m) = \psi_m \quad \text{and} \quad \|\psi_m\|_{\varepsilon_m, **} \rightarrow 0.$$

We can write, by the above decomposition, that

$$(3-7) \quad \Phi_m - i^*(i(f'(\mathcal{W}_{\varepsilon_m, \xi_m})\Phi_m)) = \psi_m + \zeta_m,$$

with  $\zeta_m = \sum_{k=1}^n (c_k)_m \mathcal{Z}_{\varepsilon_m, \xi_m}^k \in K_{\varepsilon_m, \xi_m}$ . We claim that

$$(3-8) \quad \|\zeta_m\|_{\varepsilon_m, **} \rightarrow 0.$$



Indeed, multiplying (3-7) by  $Z_{\varepsilon_m, \xi_m}^l$  for  $l = 1, \dots, n$  and integrating, taking into account that  $\Phi_m, \psi_m \in K_{\varepsilon_m, \xi_m}^\perp$ , we get

$$(3-9) \quad \sum_{k=1}^n (c_k)_m \langle Z_{\varepsilon_m, \xi_m}^k, Z_{\varepsilon_m, \xi_m}^l \rangle_{\varepsilon_m, **} = -\frac{1}{\varepsilon_m^n} \int_M f'(\mathcal{W}_{\varepsilon_m, \xi_m}) \Phi_m Z_{\varepsilon_m, \xi_m}^l d\text{vol}_g.$$

A straightforward computations yield

$$(3-10) \quad \begin{aligned} & \langle Z_{\varepsilon_m, \xi_m}^k, Z_{\varepsilon_m, \xi_m}^l \rangle_{\varepsilon_m, **} \\ &= \frac{1}{\varepsilon_m^{n-2s}} \kappa_s \left[ \int_X \rho^{1-2s} \nabla_{\bar{g}} Z_{\varepsilon_m, \xi_m}^k \nabla_{\bar{g}} Z_{\varepsilon_m, \xi_m}^l + E(\rho) Z_{\varepsilon_m, \xi_m}^k Z_{\varepsilon_m, \xi_m}^l \right] d\text{vol}_{\bar{g}} \\ & \quad + \frac{1}{\varepsilon_m^n} \int_M Z_{\varepsilon_m, \xi_m}^k Z_{\varepsilon_m, \xi_m}^l d\text{vol}_g \\ &= \kappa_s \int_{B_{r/\varepsilon_m}^+} x_N^{1-2s} |\bar{g}(\varepsilon_m x, \varepsilon_m x_N)|^{\frac{1}{2}} \\ & \quad \left[ g^{ij}(\varepsilon_m x, \varepsilon_m x_N) \partial_i (Z_k(x, x_N) \chi(\varepsilon_m x, \varepsilon_m x_N)) \right. \\ & \quad \cdot \partial_j (Z_l(x, x_N) \chi(\varepsilon_m x, \varepsilon_m x_N)) \\ & \quad \left. + \partial_N (Z_k(x, x_N) \chi(\varepsilon_m x, \varepsilon_m x_N)) \partial_N (Z_l(x, x_N) \chi(\varepsilon_m x, \varepsilon_m x_N)) \right] dx dx_N \\ & \quad + \varepsilon_m^{1+2s} \kappa_s \int_{B_{r/\varepsilon_m}^+} E(t) |\bar{g}(\varepsilon_m x, \varepsilon_m x_N)|^{\frac{1}{2}} \\ & \quad (Z_k(x, x_N) \chi(\varepsilon_m x, \varepsilon_m x_N)) (Z_l(x, x_N) \chi(\varepsilon_m x, \varepsilon_m x_N)) dx dx_N \\ & \quad + \int_{B_{r/\varepsilon_m}^+} |\bar{g}(\varepsilon x, \varepsilon x_N)|^{\frac{1}{2}} \\ & \quad (Z_k(x, x_N) \chi(\varepsilon_m x, \varepsilon_m x_N)) (Z_l(x, x_N) \chi(\varepsilon_m x, \varepsilon_m x_N)) \\ &= c \delta_{kl} + o(1), \end{aligned}$$

where  $c$  is a positive constant. Then, setting

$$\tilde{\Phi}_m(y) = \begin{cases} \chi_r(\varepsilon_m y) \Phi_m(\exp_{\xi_m}(\varepsilon_m y)) & \text{if } y \in B(0, r/\varepsilon_m), \\ 0, & \text{otherwise,} \end{cases}$$

it is easy to check that

$$\|\tilde{\Phi}_m\|_{H^1(\mathbb{R}_+^{n+1}, x_N^{1-2s})} \leq C$$

for some positive constant  $C$ . Hence,

$$\tilde{\Phi}_m \rightharpoonup \tilde{\Phi} \quad \text{in } H^1(\mathbb{R}_+^{n+1}, x_N^{1-2s}),$$

and by the compactness of the trace operator we deduce that

$$\tilde{\Phi}_m \rightarrow \tilde{\Phi} \quad \text{in } L_{\text{loc}}^q(\mathbb{R}^n) \quad \text{for any } 1 \leq q < \frac{2n}{n-2s}.$$

Using this, together with the fact that  $\Phi_m \in K_{\varepsilon_m, \xi_m}^\perp$ , we get

$$\begin{aligned}
 (3-11) \quad & -\frac{1}{\varepsilon_m^n} \int_M f'(\mathcal{W}_{\varepsilon_m, \xi_m}) \Phi_m \mathcal{Z}_{\varepsilon_m, \xi_m}^l d\text{vol}_g \\
 & = \frac{1}{\varepsilon_m^{n-2s}} \kappa_s \int_X (\rho^{1-2s} \nabla_{\bar{g}} \mathcal{Z}_{\varepsilon_m, \xi_m}^l \nabla_{\bar{g}} \Phi_m + E(\rho) \mathcal{Z}_{\varepsilon_m, \xi_m}^l \Phi_m) d\text{vol}_{\bar{g}} \\
 & \quad + \frac{1}{\varepsilon_m^n} \int_M (1 - f'(\mathcal{W}_{\varepsilon_m, \xi_m})) \Phi_m \mathcal{Z}_{\varepsilon_m, \xi_m}^l d\text{vol}_g \\
 & = \kappa_s \int_{\mathbb{R}_+^{n+1}} x_N^{1-2s} \nabla \tilde{\Phi} \nabla \tilde{\Phi} dx dx_N + \int_M (1 - f'(W)) \tilde{\Phi} \mathcal{Z}_i dx + o(1) = o(1).
 \end{aligned}$$

Combining (3-9)–(3-11), we deduce that  $(c_k)_m \rightarrow 0$  for any  $k = 1, \dots, n$ , and the claim (3-8) is proved.

Now, we consider the functions  $\varphi_m$  defined by

$$\varphi_m(y) = \begin{cases} \chi_r(\varepsilon_m y) \varphi(\exp_{\xi_m}(\varepsilon_m y)) & \text{if } y \in B(0, r/\varepsilon_m), \\ 0, & \text{otherwise} \end{cases}$$

for any function  $\varphi \in C_0^\infty(\mathbb{R}^{n+1})$ . We multiply (3-7) by  $\varphi_m$ , we get

$$\langle \Phi_m, \varphi_m \rangle_{\varepsilon_m, **} = \langle i^*(i(f'(\mathcal{W}_{\varepsilon_m, \xi_m}) \Phi_m), \varphi_m) \rangle_{\varepsilon_m, **} + \left\langle \Psi_m + \sum_{k=1}^n c_k \mathcal{Z}_{\varepsilon_m, \xi_m}^k, \varphi_m \right\rangle_{\varepsilon_m, **}.$$

Since

$$\left\langle \Psi_m + \sum_{k=1}^n c_k \mathcal{Z}_{\varepsilon_m, \xi_m}^k, \varphi_m \right\rangle_{\varepsilon_m, **} = o(1),$$

then, taking  $\varepsilon_m \rightarrow 0$ , we obtain

$$\int_{\mathbb{R}_+^{n+1}} x_N^{1-2s} \nabla \tilde{\Phi} \nabla \varphi dx dx_N = p \int_{\mathbb{R}^n} \omega^{p-1} \tilde{\Phi} \varphi dx - \int_{\mathbb{R}^n} \tilde{\Phi} \varphi dx$$

for any function  $\varphi \in C_0^\infty(\mathbb{R}^{n+1})$ . This clearly implies that  $\tilde{\Phi}$  is a weak solution of (2-7).

Moreover,

$$\|\tilde{\Phi}\|_{H^1(\mathbb{R}_+^{n+1}, x_N^{1-2s})} < \infty,$$

so the Moser iteration argument works and it reveals that  $\tilde{\Phi}$  is  $L^\infty(\mathbb{R}^n)$ -bounded (see the proof of Lemma 5.1 in [14]). This with (3-6), implies  $\tilde{\Phi} = 0$  in  $\mathbb{R}^n$ .

On the other hand, using the fact that

$$-\frac{1}{\varepsilon_m^n} \int_M f'(\mathcal{W}_{\varepsilon_m, \xi_m}) \Phi_m^2 d\text{vol}_g = -p \int_{B_{r/\varepsilon_m}^+} \mathcal{W}_{\varepsilon_m, \xi_m}^{p-1} \Phi_m^2 |\bar{g}(\varepsilon x, \varepsilon x_N)|^{\frac{1}{2}} dx = o(1),$$

together with (3-7), one deduces that

$$\|\Phi_m\|_{\varepsilon_m, **}^2 = \frac{1}{\varepsilon_m^n} \int_M f'(\mathcal{W}_{\varepsilon_m, \xi_m}) \Phi_m^2 d\text{vol}_g + \left\langle \Psi_m + \sum_{k=1}^n c_k \mathcal{Z}_{\varepsilon_m, \xi_m}^k, \Phi_m \right\rangle_{\varepsilon_m, **} = o(1),$$

which gives a contradiction with the fact that  $\|\Phi_m\|_{\varepsilon_m, **} = 1$ . This concludes the proof of the desired result.  $\square$

We next prove the following estimate on  $R_{\varepsilon, \xi}$ .

**Lemma 3.2.** *Assume that  $n > 2s + 2$ , there exists  $\varepsilon_0 > 0$  and  $c > 0$  such that for any  $\xi \in M$  and for any  $\varepsilon \in (0, \varepsilon_0)$ , we have*

$$(3-12) \quad \|R_{\varepsilon, \xi}\|_{\varepsilon, **} \leq c\varepsilon^\gamma,$$

where  $\gamma$  is given by

$$(3-13) \quad \gamma = \begin{cases} \frac{1}{2} + \zeta & \text{if } 0 < s < \frac{1}{2}, \\ 1 + \zeta & \text{if } \frac{1}{2} \leq s < 1, \end{cases}$$

where  $\zeta$  can be taken sufficiently small.

*Proof.* We first introduce some notations. Given  $R > 0$ , we denote by  $B_g^+(\xi, R)$  and  $B_g(\xi, R)$  the balls defined respectively by

$$(3-14) \quad B_g^+(\xi, R) := \{z \in X : d(z, \xi) < R\} \quad \text{and} \quad B_g(\xi, R) := \{\hat{\xi} \in M : d_M(\hat{\xi}, \xi) < R\}.$$

Next, we define by duality, the norm

$$\|U\| = \sup\{\langle U, \Phi \rangle : \|\Phi\|_{\varepsilon, **} \leq 1\}$$

for  $U \in H^1(X; \rho^{1-2s})$ . Given  $\Phi \in H^1(X; \rho^{1-2s})$  with  $\|\Phi\|_{\varepsilon, **} \leq 1$  and set  $\phi = i(\Phi)$ , we clearly have

$$(3-15) \quad \begin{aligned} & \langle \mathcal{W}_{\varepsilon, \xi}, \Phi \rangle_{\varepsilon, **} - \langle i(\mathcal{W}_{\varepsilon, \xi}^p), \phi \rangle \\ &= \frac{1}{\varepsilon^{n-2s}} \kappa_s \int_{B_g^+(\xi, 2r_0)} \rho^{1-2s} (\nabla \mathcal{W}_{\varepsilon, \xi}, \nabla \Phi)_{\bar{g}} d\text{vol}_{\bar{g}} \\ & \quad + \frac{1}{\varepsilon^n} \int_{B_g(\xi, 2r_0)} (\mathcal{W}_{\varepsilon, \xi} - \mathcal{W}_{\varepsilon, \xi}^p) \phi d\text{vol}_g \\ & \quad + \frac{1}{\varepsilon^{n-2s}} \kappa_s \int_{B_g^+(\xi, 2r_0)} E(\rho) \mathcal{W}_{\varepsilon, \xi} \Phi d\text{vol}_{\bar{g}} \\ &= -\frac{1}{\varepsilon^{n-2s}} \kappa_s \int_{B_g^+(\xi, 2r_0)} \text{div}_{\bar{g}}(\rho^{1-2s} \nabla \mathcal{W}_{\varepsilon, \xi}) \Phi d\text{vol}_{\bar{g}} \\ & \quad + \frac{1}{\varepsilon^{n-2s}} \kappa_s \int_{B_g^+(\xi, 2r_0)} E(\rho) \mathcal{W}_{\varepsilon, \xi} \Phi d\text{vol}_{\bar{g}}. \end{aligned}$$

We set

$$(3-16) \quad \mathcal{I}_1 := -\frac{1}{\varepsilon^{n-2s}} \kappa_s \int_{B_{\bar{g}}^+(\xi, 2r_0)} \operatorname{div}_{\bar{g}}(\rho^{1-2s} \nabla \mathcal{W}_{\varepsilon, \xi}) \Phi \, d\operatorname{vol}_{\bar{g}},$$

$$(3-17) \quad \mathcal{I}_2 := \frac{1}{\varepsilon^{n-2s}} \kappa_s \int_{B_{\bar{g}}^+(\xi, 2r_0)} E(\rho) \mathcal{W}_{\varepsilon, \xi} \Phi \, d\operatorname{vol}_{\bar{g}}.$$

We first estimate  $\mathcal{I}_1$ . Recalling the definition of  $\mathcal{W}_{\varepsilon, \xi}$  given in (2-24) we can write

$$\begin{aligned} \mathcal{I}_1 &= -\frac{1}{\varepsilon^{n-2s}} \kappa_s \int_{B_{\bar{g}}^+(\xi, 2r_0)} \chi_r \operatorname{div}_{\bar{g}}(\rho^{1-2s} \nabla W_\varepsilon) \Phi \, d\operatorname{vol}_{\bar{g}} \\ &\quad - \frac{1}{\varepsilon^{n-2s}} \kappa_s \int_{B_{\bar{g}}^+(\xi, 2r_0)} \operatorname{div}_{\bar{g}}(\rho^{1-2s} \nabla \chi_r) W_\varepsilon \Phi \, d\operatorname{vol}_{\bar{g}} \\ &\quad - \frac{2}{\varepsilon^{n-2s}} \kappa_s \int_{B_{\bar{g}}^+(\xi, 2r_0)} \rho^{1-2s} \nabla \chi_r \cdot \nabla W_\varepsilon \Phi \, d\operatorname{vol}_{\bar{g}}. \end{aligned}$$

Using the Taylor expansions of the metric given in Lemma 2.3, we get

$$\begin{aligned} \mathcal{I}_1 &= -\frac{1}{\varepsilon^{n-2s}} \kappa_s \int_{\mathbb{R}_+^{n+1}} \operatorname{div}(t^{1-2s} \nabla W_\varepsilon) \Phi \, dx \, dt \\ &\quad + \frac{1}{\varepsilon^{n-2s}} \int t^{1-2s} \mathcal{O}(t + |(x, t)|^2) |\nabla W_\varepsilon| |\nabla \Phi| \, dx \, dt \\ &\quad + \frac{1}{\varepsilon^{n-2s}} \mathcal{O}\left(\varepsilon^2 \int_{B_{\bar{g}}^+(\xi, 2r_0)} \rho^{1-2s} |W_\varepsilon| |\Phi| \, d\operatorname{vol}_{\bar{g}}\right) \\ &\quad + \frac{1}{\varepsilon^{n-2s}} \mathcal{O}\left(\varepsilon \int_{B_{\bar{g}}^+(\xi, 2r_0)} \rho^{-2s} |W_\varepsilon| |\Phi| \, d\operatorname{vol}_{\bar{g}}\right) \\ &\quad + \frac{1}{\varepsilon^{n-2s}} \mathcal{O}\left(\varepsilon^2 \int_{B_{\bar{g}}^+(\xi, 2r_0)} \rho^{1-2s} |\nabla W_\varepsilon| |\Phi| \, d\operatorname{vol}_{\bar{g}}\right). \end{aligned}$$

Using the fact that  $W_\varepsilon$  solves (2-5), the estimates of Lemma 2.7 and Cauchy-Schwarz inequality, we can easily deduce that

$$|\mathcal{I}_1| = \mathcal{O}(\varepsilon^{1+\zeta})$$

for some  $\zeta > 0$  which can be chosen small enough.

Now, to estimate the second term  $\mathcal{I}_2$  we argue as in the proof of Lemma 4.1 in [13].

• For  $0 < s < \frac{1}{2}$ , we can choose  $\zeta_1 > 0$  small enough so that  $s + \zeta_1 < \frac{1}{2}$ . We obtain

$$\begin{aligned} |\mathcal{I}_2| &= \left| \kappa_s \frac{1}{\varepsilon^{n-2s}} \int_{B_{\bar{g}}^+} E(\rho) \mathcal{W}_{\varepsilon, \xi} \Phi \, d\operatorname{vol}_{\bar{g}} \right| \\ &\leq \frac{C}{\varepsilon^{n-2s}} \int_{B_{\bar{g}}^+} \rho^{-2s} |\mathcal{W}_{\varepsilon, \xi}| |\Phi| \, d\operatorname{vol}_{\bar{g}} \end{aligned}$$

$$\begin{aligned}
&\leq C \left( \frac{1}{\varepsilon^{n-2s}} \int_{B_{\bar{g}}^+} \rho^{1-2s-2(s+\xi_1)} \mathcal{W}_{\varepsilon, \xi}^2 d\text{vol}_{\bar{g}} \right)^{1/2} \left( \frac{1}{\varepsilon^{n-2s}} \int_{B_{\bar{g}}^+} \rho^{-1+2\xi_1} \Phi^2 d\text{vol}_{\bar{g}} \right)^{1/2} \\
&\leq C \left( \frac{1}{\varepsilon^{n-2s}} \int_{B_{2r_0}^+} t^{1-2s-2(s+\xi_1)} W_{\varepsilon}^2(z) dz \right)^{1/2} = \mathcal{O}(\varepsilon^{1-(s+\xi_1)}) = \mathcal{O}(\varepsilon^{\frac{1}{2}+\xi_3}),
\end{aligned}$$

with  $\xi_3 = \frac{1}{2} - (s + \xi_1) > 0$ .

• For  $\frac{1}{2} < s < 1$  and  $H = 0$ , we can choose  $\zeta_2 > 0$  small enough so that  $s + \zeta_2 < 1$ . Arguing as above, we get by (1-20) that

$$\begin{aligned}
(3-18) \quad &\left| \kappa_s \frac{1}{\varepsilon^{n-2s}} \int_{B_{\bar{g}}^+} E(\rho) \mathcal{W}_{\varepsilon, \xi} \Phi dv_{\bar{g}} \right| \\
&\leq \frac{C}{\varepsilon^{n-2s}} \int_{B_{\bar{g}}^+} \rho^{1-2s} |\mathcal{W}_{\varepsilon, \xi}| |\Phi| dv_{\bar{g}} \\
&\leq C \left( \frac{1}{\varepsilon^{n-2s}} \int_{B_{\bar{g}}^+} \rho^{1-2s+2\xi_2} \mathcal{W}_{\varepsilon, \xi}^2 dv_{\bar{g}} \right)^{1/2} \left( \frac{1}{\varepsilon^{n-2s}} \int_{B_{\bar{g}}^+} \rho^{1-2s-2\xi_2} \Phi^2 dv_{\bar{g}} \right)^{1/2} \\
&\leq C \left( \frac{1}{\varepsilon^{n-2s}} \int_{B_{2r_0}^+} t^{1-2s+2\xi_2} W_{\varepsilon}^2(z) dz \right)^{1/2} = \mathcal{O}(\varepsilon^{1+\xi_2}).
\end{aligned}$$

Combining the above estimates, the desired result follows at once.  $\square$

Finally and in order to solve (2-31), it is important to study the linear operator  $L_{\varepsilon, \xi}$  defined in (3-1). To this aim, we let  $\Psi = L_{\varepsilon, \xi}(\Phi)$ , we have that

$$(3-19) \quad \begin{cases} \Phi - i^*(i(f'(\mathcal{W}_{\varepsilon, \xi})\Phi)) = \Psi + \sum_{k=1}^n c_{\varepsilon}^k \mathcal{Z}_{\varepsilon, \xi}^k & \text{in } X \\ \langle \Phi, \mathcal{Z}_{\varepsilon, \xi}^k \rangle = 0 & \text{for all } k = 1, \dots, n \end{cases}$$

for some constants  $c_{\varepsilon}^1, \dots, c_{\varepsilon}^n \in \mathbb{R}$ . In the next proposition, we prove that for a fixed  $\Psi \in (K_{\varepsilon, \xi})^{\perp}$  there are a unique function  $\Phi \in (K_{\varepsilon, \xi})^{\perp}$  and an  $(n)$ -tuple  $(c_{\varepsilon}^1, \dots, c_{\varepsilon}^n) \in \mathbb{R}^n$  satisfying the linear problem (3-19). Precisely, we prove the following result.

**Proposition 3.3.** *Given  $n > 2s$ ,  $\xi \in M$  and  $\varepsilon > 0$  a small parameter. Then, for any  $\Psi \in (K_{\varepsilon, \xi})^{\perp}$ , there exists a unique solution  $(\Phi, (c_{\varepsilon}^1, \dots, c_{\varepsilon}^n))$  to the equation (3-19) such that the estimate (3-5) holds.*

*Proof.* The existence of a unique solution follows directly from Lemma 2.6 and the Fredholm alternative for compact operator.  $\square$

A consequence of the above proposition is the following result.

**Proposition 3.4.** *Under the assumption of Proposition 3.3, equation (2-31) possesses a unique solution  $\Phi = \Phi_{\varepsilon, \xi} \in (K_{\varepsilon, \xi})^{\perp}$  such that*

$$(3-20) \quad \|\Phi_{\varepsilon, \xi}\|_{\varepsilon, **} \leq c\varepsilon^{\gamma},$$

with a positive constant  $c$  and where  $\gamma$  is defined in (3-13).

*Proof.* The proof is based on a contraction mapping theorem. Indeed, let us define the operator  $T_{\varepsilon,\xi} : (K_{\varepsilon,\xi})^\perp \rightarrow (K_{\varepsilon,\xi})^\perp$  by

$$(3-21) \quad T_{\varepsilon,\xi}(\Phi) := (L_{\varepsilon,\xi})^{-1}(N_{\varepsilon,\xi}(\Phi) + R_{\varepsilon,\xi}).$$

Using Lemma 3.2, a straightforward computations show that  $T_{\varepsilon,\xi}$  is a contraction map from the ball

$$(3-22) \quad \mathcal{B} := \{\Phi \in (K_{\varepsilon,\xi})^\perp : \|\Phi\|_{\varepsilon,**} \leq C\varepsilon^\gamma\}$$

into itself, for some large constant  $C > 0$ . Hence,  $T_{\varepsilon,\xi}$  possesses a unique fixed point  $\Phi_{\varepsilon,\xi} \in \mathcal{B}$ , which is a solution to (3-2), or equivalently to (2-31).  $\square$

#### 4. Asymptotic expansion of the finite-dimensional functional

The goal is to solve (2-32). Let  $J_\varepsilon : H^1(X, \rho^{1-2s}) \rightarrow \mathbb{R}$  be defined by

$$J_\varepsilon(U) := \frac{1}{2\varepsilon^{n-2s}} \kappa_s \int_X (\rho^{1-2s} |\nabla U|_{\bar{g}}^2 + E(\rho) U^2) d\text{vol}_{\bar{g}} + \frac{1}{\varepsilon^n} \int_M \frac{1}{2} U^2 - F(U) d\text{vol}_g,$$

where  $u_+ = \max(u, 0)$  and  $F(u) := \frac{1}{p+1} u_+^{p+1}$  so that  $F'(u) = f(u)$ . It is well known that any critical point of  $J_\varepsilon$  is solution to problem (1-1).

Next, we introduce the reduced functional  $\tilde{J}_\varepsilon : M \rightarrow \mathbb{R}$  defined by

$$(4-1) \quad \tilde{J}_\varepsilon(\xi) := J_\varepsilon(\mathcal{W}_{\varepsilon,\xi} + \Phi_{\varepsilon,\xi}), \quad \xi \in M,$$

where  $\mathcal{W}_{\varepsilon,\xi}$  is the global approximate solution given in (2-24) and  $\Phi_{\varepsilon,\xi}$  is a small perturbation defined in (2-25). Applying a finite dimensional reduction procedure, we prove the following result

**Lemma 4.1.** *The reduced energy functional  $\tilde{J}_\varepsilon$  is continuously differentiable. Moreover, if  $\xi_0$  is a critical point of  $\tilde{J}_\varepsilon$ , then  $\mathcal{W}_{\varepsilon,\xi_0} + \Phi_{\varepsilon,\xi_0}$  is a positive solution to problem (1-1) or equivalently to problem (2-32).*

*Proof.* Given  $\xi \in M$ , we define the linear operator,  $\mathcal{H}(\xi, \cdot) : H^1(X, \rho^{1-2s}) \rightarrow \mathbb{R}$  by

$$(4-2) \quad \mathcal{H}(\xi, U) := U + \Pi_{\varepsilon,\xi}^\perp [\mathcal{W}_{\varepsilon,\xi} - i_\varepsilon^*(i(f(\mathcal{W}_{\varepsilon,\xi} + U)))]$$

for  $U \in H^1(X, \rho^{1-2s})$ . We clearly have

$$\mathcal{H}(\xi, \Phi_{\varepsilon,\xi}) = 0 \quad \text{and} \quad \frac{\partial \mathcal{H}}{\partial U}(\xi, \Phi_{\varepsilon,\xi})U = U - \Pi_{\varepsilon,\xi}^\perp [i_\varepsilon^*(i(f'(\mathcal{W}_{\varepsilon,\xi} + \Phi_{\varepsilon,\xi})U))].$$

On the other hand, using Lemma 2.6, we deduce that

$$i(f'(\mathcal{W}_{\varepsilon,\xi} + \Phi_{\varepsilon,\xi})U) \in L^q(M)$$

for some  $q \in (1, \frac{n+2s}{n-2s})$  with

$$U \in H^1(X, \rho^{1-2s}) \quad \text{and} \quad \frac{\partial \mathcal{H}}{\partial U}(\xi, \Phi_{\varepsilon, \xi}) : H^1(X, \rho^{1-2s}) \rightarrow H^1(X, \rho^{1-2s})$$

is a Fredholm operator of index 0. Moreover, using (3-12) one can easily check that it is also injective. Therefore  $\frac{\partial \mathcal{H}}{\partial U}(\xi, \Phi_{\varepsilon, \xi})$  is invertible and by the implicit function theorem, we deduce that the mapping

$$\xi \in M \mapsto \Phi_{\varepsilon, \xi} \in H^1(X, \rho^{1-2s})$$

is  $C^1$ . This proves that  $\tilde{J}_\varepsilon$  is of class  $C^1$ . It then remains to prove that  $\tilde{J}'_\varepsilon(\xi) = 0$  implies that

$$J'_\varepsilon(\mathcal{W}_{\varepsilon, \xi} + \Phi_{\varepsilon, \xi}) = 0.$$

Let  $\xi_0 \in M$  and define

$$\xi = \xi(y) = \exp_{\xi_0}(y), \quad y \in B(0, r) \subset T_{\xi_0}M$$

with  $r > 0$ . A straightforward computations yield

$$\begin{aligned} & \frac{\partial}{\partial y_k} \tilde{J}_\varepsilon(\exp_{\xi_0}(y)) \\ &= J'_\varepsilon(\mathcal{W}_{\varepsilon, \xi(y)} + \Phi_{\varepsilon, \xi(y)}) \left[ \frac{\partial}{\partial y_k} \mathcal{W}_{\varepsilon, \xi(y)} + \frac{\partial}{\partial y_k} \Phi_{\varepsilon, \xi(y)} \right] \\ &= \left\langle \mathcal{W}_{\varepsilon, \xi(y)} + \Phi_{\varepsilon, \xi(y)} - i^*(i(f(\mathcal{W}_{\varepsilon, \xi(y)} + \Phi_{\varepsilon, \xi(y)}))), \left( \frac{\partial}{\partial y_k} \mathcal{W}_{\varepsilon, \xi(y)} + \frac{\partial}{\partial y_k} \Phi_{\varepsilon, \xi(y)} \right) \right\rangle_{\varepsilon, **}. \end{aligned}$$

On the other hand, by (3-19), there exist some constants  $c_\varepsilon^l$ ,  $1 \leq l \leq n$ , such that

$$\mathcal{W}_{\varepsilon, \xi(y)} + \Phi_{\varepsilon, \xi(y)} - i^*(i(f(\mathcal{W}_{\varepsilon, \xi(y)} + \Phi_{\varepsilon, \xi(y)}))) = \sum_{l=1}^n c_\varepsilon^l \mathcal{Z}_{\varepsilon, \xi(y)}^l.$$

Therefore

$$(4-3) \quad \frac{\partial}{\partial y_k} \tilde{J}_\varepsilon(\exp_{\xi_0}(y)) = \sum_{l=1}^n c_\varepsilon^l \left\langle \mathcal{Z}_{\varepsilon, \xi(y)}^l, \frac{\partial}{\partial y_k} \mathcal{W}_{\varepsilon, \xi(y)} + \frac{\partial}{\partial y_k} \Phi_{\varepsilon, \xi(y)} \right\rangle_{\varepsilon, **}.$$

Assuming now that  $\xi_0$  is a critical point of  $\tilde{J}_\varepsilon$ . That is,

$$(4-4) \quad \left( \frac{\partial}{\partial y_k} \tilde{J}_\varepsilon(\exp_{\xi_0}(y)) \right) \Big|_{y=0} = 0 \quad \text{for all } k = 1, \dots, n.$$

Evaluating (4-3) at  $y = 0$  and assuming  $\varepsilon$  sufficiently small, we immediately get from Lemma 4.8 that  $c_\varepsilon^l = 0$  for all  $l = 1, \dots, n$ .

To prove that  $\mathcal{W}_{\varepsilon, \xi(y)} + \Phi_{\varepsilon, \xi(y)}$  is positive, we argue as in [13, Proof of Proposition 5.1]. In fact, given any  $\Psi \in H^1(X, \rho^{1-2s})$  we have

$$\begin{aligned} & \frac{1}{\varepsilon^{n-2s}} \int_X (\rho^{1-2s} (\nabla(\mathcal{W}_{\varepsilon, \xi(y)} + \Phi_{\varepsilon, \xi(y)}), \nabla\Psi)_{\bar{g}} + E(\rho)(\mathcal{W}_{\varepsilon, \xi(y)} + \Phi_{\varepsilon, \xi(y)}) \Psi) d\text{vol}_{\bar{g}} \\ & \quad + \frac{1}{\varepsilon^n} \int_M (\mathcal{W}_{\varepsilon, \xi(y)} + \Phi_{\varepsilon, \xi(y)}) \Psi d\text{vol}_g \\ & = \frac{p}{\varepsilon^n} \int_M (\mathcal{W}_{\varepsilon, \xi(y)} + \Phi_{\varepsilon, \xi(y)})_+^{p-1} \Psi d\text{vol}_g. \end{aligned}$$

Then, choosing  $\Psi = (\mathcal{W}_{\varepsilon, \xi(y)} + \Phi_{\varepsilon, \xi(y)})_-$  into the above identity and using (2-17) we immediately get that  $\mathcal{W}_{\varepsilon, \xi(y)} + \Phi_{\varepsilon, \xi(y)}$  is nonnegative in  $\bar{X}$ . The fact that it is positive follows from the inequality

$$\|\mathcal{W}_{\varepsilon, \xi(y)} + \Phi_{\varepsilon, \xi(y)}\|_{\varepsilon, **} \geq \|\mathcal{W}_{\varepsilon, \xi(y)}\|_{\varepsilon, **} - \|\Phi_{\varepsilon, \xi(y)}\|_{\varepsilon, **} \geq C + O(\varepsilon^\gamma) > 0$$

and that (2-22) is a uniformly elliptic equation in divergence form away from the boundary  $M$ .  $\square$

**4A.  $C^0$ -estimates of the energy.** This section is devoted to the expansion of the energy functional  $\tilde{J}_\varepsilon$  in powers of  $\varepsilon$ . The first important result is the following one.

**Lemma 4.2.** *Assume that  $n > 2s + 2$ , for  $\varepsilon > 0$  sufficiently small, we suppose that  $H = 0$  if  $s \in [\frac{1}{2}, 1)$  (which is the case when (1-21) holds). We have the validity of the following expansion for the function  $J_\varepsilon$*

$$(4-5) \quad \begin{aligned} J_\varepsilon(\mathcal{W}_{\varepsilon, \xi}) - \tilde{C} \\ = \begin{cases} -\varepsilon \tilde{d}_2 H(\xi) + o(\varepsilon) & \text{if } 0 < s < \frac{1}{2}, \\ -\frac{1}{6} \varepsilon^2 [(\tilde{d} + \tilde{d}_1 \tilde{C}_{n,s}^2) R_g(\xi) + \tilde{d}_1 \tilde{C}_{n,s}^3 \|\pi\|^2(\xi)] + o(\varepsilon^2) & \text{if } \frac{1}{2} \leq s < 1, \end{cases} \end{aligned}$$

uniformly with respect to  $\xi$  as  $\varepsilon$  goes to zero. Here  $R_g$  is the scalar curvature of  $(M, g)$ ,  $\pi$  is the second fundamental form on  $M$ , the constants  $\tilde{C}$ ,  $\tilde{d}$ ,  $\tilde{d}_1$  and  $\tilde{d}_2$  are defined respectively by

$$(4-6) \quad \tilde{C} := \left( \frac{1}{2} \kappa_s \int_{\mathbb{R}^{n+1}_+} x_N^{1-2s} |\nabla W|^2 dx dx_N + \frac{1}{2} \int_{\mathbb{R}^n} \omega^2 dx - \frac{1}{p+1} \int_{\mathbb{R}^n} \omega^{p+1} dx \right),$$

$$(4-7) \quad \tilde{d} := \left( \frac{1}{2} \kappa_s \int_{\mathbb{R}^{n+1}_+} x_N^{1-2s} x_1^2 |\nabla W|^2 dx dx_N + \frac{1}{2} \int_{\mathbb{R}^n} x_1^2 \omega^2 dx - \frac{1}{p+1} \int_{\mathbb{R}^n} x_1^2 \omega^{p+1} dx \right),$$

$$(4-8) \quad \tilde{d}_1 := \kappa_s \int_{\mathbb{R}^{n+1}_+} x_N^{1-2s} W^2 dx dx_N,$$

$$(4-9) \quad \tilde{d}_2 := C_{n,s}^2 \kappa_s \int_{\mathbb{R}^{n+1}_+} x_N^{2-2s} |\nabla W|^2 dx dx_N.$$



Here  $W = \text{Ext}^s(w)$  is the  $s$ -harmonic extension of  $\omega$  to  $\mathbb{R}_+^{n+1}$  harmonic of  $w$  defined in Section 2.

*Proof.* We recall that

$$J_\varepsilon(\mathcal{W}_{\varepsilon,\xi}) := \frac{1}{2\varepsilon^{n-2s}} \kappa_s \int_X (\rho^{1-2s} |\nabla \mathcal{W}_{\varepsilon,\xi}|_{\bar{g}}^2 + E(\rho) \mathcal{W}_{\varepsilon,\xi}^2) d\text{vol}_{\bar{g}} \\ + \frac{1}{\varepsilon^n} \int_M \frac{1}{2} \mathcal{W}_{\varepsilon,\xi}^2 - F(\mathcal{W}_{\varepsilon,\xi}) d\text{vol}_g.$$

According to Lemma 2.3 and 4.4 and for  $0 < s < \frac{1}{2}$ , we obtain that

$$(4-10) \quad \frac{1}{2\varepsilon^{n-2s}} \kappa_s \int_X \rho^{1-2s} |\nabla \mathcal{W}_{\varepsilon,\xi}|_{\bar{g}}^2 d\text{vol}_{\bar{g}} \\ = \frac{1}{2} \kappa_s \int_{B_{2r_0/\varepsilon}^+} x_N^{1-2s} [\bar{g}^{ij}(\varepsilon x, \varepsilon x_N) \partial_i W \partial_j W + (\partial_N W)^2] |\bar{g}(\varepsilon x, \varepsilon x_N)|^{\frac{1}{2}} dx dx_N \\ = \frac{1}{2} \kappa_s \int_{\mathbb{R}_+^{n+1}} x_N^{1-2s} |\nabla W|^2 dx dx_N \\ - \varepsilon \kappa_s \left[ \frac{1}{2} H \int_{\mathbb{R}_+^{n+1}} x_N^{2-2s} |\nabla W|^2 dx dx_N - \pi_{ij} \int_{\mathbb{R}_+^{n+1}} x_N^{2-2s} \partial_i W \partial_j W dx dx_N \right] \\ = \frac{1}{2} \kappa_s \int_{\mathbb{R}_+^{n+1}} x_N^{1-2s} |\nabla W|^2 dx dx_N - C_{n,s}^0 \varepsilon H \kappa_s \int_{\mathbb{R}_+^{n+1}} x_N^{2-2s} |\nabla W|^2 dx dx_N \\ + o(\varepsilon).$$

Also, in view of (1-20) and for  $0 < s < \frac{1}{2}$ , we get

$$(4-11) \quad E(x_N) = \left( \frac{n-2s}{2} \right) H \rho^{-2s}$$

for  $x_N \geq 0$  small. So

$$(4-12) \quad \frac{1}{2\varepsilon^{n-2s}} \kappa_s \int_X (E(\rho) \mathcal{W}_{\varepsilon,\xi}^2) d\text{vol}_{\bar{g}} \\ = \frac{\varepsilon^{1+2s}}{2} \kappa_s \int_{B_{2r_0/\varepsilon}^+} (E(\varepsilon x_N) W^2) |\bar{g}(\varepsilon x, \varepsilon x_N)|^{\frac{1}{2}} dx dx_N \\ = \varepsilon H \kappa_s \left( \frac{n-2s}{4} \right) \int_{\mathbb{R}_+^{n+1}} x_N^{-2s} W^2 dx dx_N + o(\varepsilon^2) \\ = C_{n,s}^1 \varepsilon H \kappa_s \int_{\mathbb{R}_+^{n+1}} x_N^{2-2s} |\nabla W|^2 dx dx_N + o(\varepsilon).$$

Using the fact that  $x_N = 0$  on  $M$ , we get

$$(4-13) \quad \frac{1}{2\varepsilon^n} \int_M \mathcal{W}_{\varepsilon,\xi}^2 d\text{vol}_g = \frac{1}{2} \int_{B_{2r_0/\varepsilon}} \omega^2 |\bar{g}(\varepsilon x, \varepsilon x_N)|^{\frac{1}{2}} dx = \frac{1}{2} \int_{\mathbb{R}^n} \omega^2 dx + o(\varepsilon),$$

and

$$(4-14) \quad -\frac{1}{(p+1)\varepsilon^n} \int_M \mathcal{W}_{\varepsilon, \xi}^{p+1} d\text{vol}_g = -\frac{1}{p+1} \int_{B_{2r_0/\varepsilon}} W^{p+1} |\bar{g}(\varepsilon x, \varepsilon x_N)|^{\frac{1}{2}} dx \\ = -\frac{1}{p+1} \int_{\mathbb{R}^n} W^{p+1} dx + o(\varepsilon).$$

According to (4-10), (4-12), (4-13) and (4-14), then for  $0 < s < \frac{1}{2}$ , we get

$$J_\varepsilon(\mathcal{W}_{\varepsilon, \xi}) - \left( \frac{1}{2} \kappa_s \int_{\mathbb{R}_+^{n+1}} x_N^{1-2s} |\nabla W|^2 dx dx_N + \frac{1}{2} \int_{\mathbb{R}^n} \omega^2 dx - \frac{1}{p+1} \int_{\mathbb{R}^n} \omega^{p+1} dx \right) \\ = -C_{n,s}^2 \varepsilon H \kappa_s \int_{\mathbb{R}_+^{n+1}} x_N^{2-2s} |\nabla W|^2 dx dx_N + o(\varepsilon).$$

In the above estimates, the constants  $C_{n,s}^i$ ,  $i = 0, 1, 2$ , are defined by

$$C_{n,s}^0 := \frac{2(n-s)-1}{4n}, \quad C_{n,s}^1 := \frac{n-2s}{2-4s} \quad \text{and} \quad C_{n,s}^2 := C_{n,s}^0 - C_{n,s}^1.$$

Now, we deal with the case where  $\frac{1}{2} \leq s < 1$ . By Lemmas 2.3 and 2.5, using the result of Lemma 7.2 in [26], we get

$$(4-15) \quad \frac{1}{2\varepsilon^{n-2s}} \kappa_s \int_X \rho^{1-2s} |\nabla \mathcal{W}_{\varepsilon, \xi}|_{\bar{g}}^2 d\text{vol}_{\bar{g}} \\ = \frac{1}{2} \kappa_s \int_{B_{2r_0/\varepsilon}} x_N^{1-2s} [\bar{g}^{ij}(\varepsilon x, \varepsilon x_N) \partial_i W \partial_j W + (\partial_N W)^2] |\bar{g}(\varepsilon x, \varepsilon x_N)|^{\frac{1}{2}} dx dx_N \\ = \frac{1}{2} \kappa_s \int_{\mathbb{R}_+^{n+1}} x_N^{1-2s} |\nabla W|^2 dx dx_N + \varepsilon \kappa_s \pi_{ij} \int_{\mathbb{R}_+^{n+1}} x_N^{2-2s} \partial_i W \partial_j W dx dx_N \\ + \varepsilon^2 \kappa_s \pi_{ij,k} \int_{\mathbb{R}_+^{n+1}} x_N^{2-2s} x_k \partial_i W \partial_j W dx dx_N \\ - \frac{1}{6} \varepsilon^2 \kappa_s \left[ \frac{1}{2} R_{kl} \int_{\mathbb{R}_+^{n+1}} x_N^{1-2s} x_k x_l |\nabla W|^2 dx dx_N \right. \\ \left. - R_{ijkl} \int_{\mathbb{R}_+^{n+1}} x_N^{1-2s} x_k x_l \partial_i W \partial_j W dx dx_N \right] \\ + \frac{1}{2} \varepsilon^2 \kappa_s (3\pi_{ih} \pi_{hj} + R_{iNjN}) \int_{\mathbb{R}_+^{n+1}} x_N^{3-2s} \partial_i W \partial_j W dx dx_N \\ - \frac{1}{4} \varepsilon^2 \kappa_s (\|\pi\|^2 + R_{NN}) \int_{\mathbb{R}_+^{n+1}} x_N^{3-2s} |\nabla W|^2 dx dx_N \\ + o(\varepsilon^2) \\ = \frac{1}{2} \kappa_s \int_{\mathbb{R}_+^{n+1}} x_N^{1-2s} |\nabla W|^2 dx dx_N - \frac{1}{12} \varepsilon^2 \kappa_s R_{kk} \int_{\mathbb{R}_+^{n+1}} x_N^{1-2s} x_1^2 |\nabla W|^2 dx dx_N \\ - \frac{1}{6} \varepsilon^2 \kappa_s [\tilde{C}_{n,s}^0 (\|\pi\|^2 + R_{NN}) + \tilde{C}_{n,s}^1 \|\pi\|^2] \int_{\mathbb{R}_+^{n+1}} x_N^{1-2s} W^2 dx dx_N \\ + o(\varepsilon^2).$$

Using the fact that  $x_N = 0$  on  $M$ , we get

$$(4-16) \quad \begin{aligned} \frac{1}{2\varepsilon^n} \int_M \mathcal{W}_{\varepsilon, \xi}^2 d\text{vol}_g &= \frac{1}{2} \int_{B_{2r_0/\varepsilon}} \omega^2 |\bar{g}(\varepsilon x, \varepsilon x_N)|^{\frac{1}{2}} dx \\ &= \frac{1}{2} \int_{\mathbb{R}^n} \omega^2 dx - \frac{1}{12} \varepsilon^2 R_{kk} \int_{\mathbb{R}^n} x_1^2 \omega^2 dx + o(\varepsilon^2), \end{aligned}$$

and

$$(4-17) \quad \begin{aligned} -\frac{1}{(p+1)\varepsilon^n} \int_M \mathcal{W}_{\varepsilon, \xi}^{p+1} d\text{vol}_g &= -\frac{1}{p+1} \int_{B_{2r_0/\varepsilon}} \omega^{p+1} |\bar{g}(\varepsilon x, \varepsilon x_N)|^{\frac{1}{2}} dx \\ &= -\frac{1}{p+1} \int_{\mathbb{R}^n} \omega^{p+1} dx + \frac{1}{p+1} \varepsilon^2 R_{kk} \int_{\mathbb{R}^n} x_1^2 \omega^{p+1} dx + o(\varepsilon^2). \end{aligned}$$

Here  $\tilde{C}_{n,s}^0$  and  $\tilde{C}_{n,s}^1$  are the constants defined by

$$(4-18) \quad \tilde{C}_{n,s}^0 := \left( \frac{3n-2(1+s)}{n} \right) (1-s), \quad \tilde{C}_{n,s}^1 := \frac{4}{n} (1-s^2).$$

Then according to (4-15), (4-16) and (4-17), we get

$$\begin{aligned} J_\varepsilon(\mathcal{W}_{\varepsilon, \xi}) &- \left( \frac{1}{2} \kappa_s \int_{\mathbb{R}_+^{n+1}} x_N^{1-2s} |\nabla W|^2 dx dx_N + \frac{1}{2} \int_{\mathbb{R}^n} \omega^2 dx - \frac{1}{p+1} \int_{\mathbb{R}^n} \omega^{p+1} dx \right) \\ &= -\frac{1}{6} \varepsilon^2 R_{kk}(\xi) \left[ \frac{1}{2} \kappa_s \int_{\mathbb{R}_+^{n+1}} x_N^{1-2s} x_1^2 |\nabla W|^2 dx dx_N \right. \\ &\quad \left. + \frac{1}{2} \int_{\mathbb{R}^n} x_1^2 \omega^2 dx - \frac{1}{p+1} \int_{\mathbb{R}^n} x_1^2 \omega^{p+1} dx \right] \\ &- \frac{1}{6} \varepsilon^2 \kappa_s [\tilde{C}_{n,s}^0 (\|\pi\|^2 + R_{NN}) + \tilde{C}_{n,s}^1 \|\pi\|^2] (\xi) \int_{\mathbb{R}_+^{n+1}} x_N^{1-2s} W^2 dx dx_N \\ &+ o(\varepsilon^2). \end{aligned}$$

Substituting the second identity in (1-22) into the above, we obtain

$$\begin{aligned} J_\varepsilon(\mathcal{W}_{\varepsilon, \xi}) &- \left( \frac{1}{2} \kappa_s \int_{\mathbb{R}_+^{n+1}} x_N^{1-2s} |\nabla W|^2 dx dx_N + \frac{1}{2} \int_{\mathbb{R}^n} \omega^2 dx - \frac{1}{p+1} \int_{\mathbb{R}^n} \omega^{p+1} dx \right) \\ &= -\frac{1}{6} \varepsilon^2 R_{kk}(\xi) \left[ \frac{1}{2} \kappa_s \int_{\mathbb{R}_+^{n+1}} x_N^{1-2s} x_1^2 |\nabla W|^2 dx dx_N \right. \\ &\quad \left. + \frac{1}{2} \int_{\mathbb{R}^n} x_1^2 \omega^2 dx - \frac{1}{p+1} \int_{\mathbb{R}^n} x_1^2 \omega^{p+1} dx \right] \\ &- \frac{1}{6} \varepsilon^2 \kappa_s [\tilde{C}_{n,s}^3 \|\pi\|^2 + \tilde{C}_{n,s}^2 R_{kk}] (\xi) \int_{\mathbb{R}_+^{n+1}} x_N^{1-2s} W^2 dx dx_N \\ &+ o(\varepsilon^2), \end{aligned}$$

where

$$(4-19) \quad \tilde{C}_{n,s}^2 := \frac{\tilde{C}_{n,s}^0}{2(n-1)} \quad \text{and} \quad \tilde{C}_{n,s}^3 := \tilde{C}_{n,s}^1 - \tilde{C}_{n,s}^2.$$

Recalling the definitions of the constants  $\tilde{C}$ ,  $\tilde{d}$ ,  $\tilde{d}_1$  and  $\tilde{d}_2$  given respectively in (4-6), (4-7), (4-8) and (4-9), the proof follows at once.  $\square$

**Lemma 4.3.** *Given  $\varepsilon > 0$  sufficiently small, we have*

$$(4-20) \quad \tilde{J}_\varepsilon(\xi) := J_\varepsilon(\mathcal{W}_{\varepsilon,\xi} + \Phi_{\varepsilon,\xi}) = J_\varepsilon(\mathcal{W}_{\varepsilon,\xi}) + \mathcal{O}(\varepsilon^{2\gamma}),$$

uniformly with respect to  $\xi \in M$  as  $\varepsilon$  goes to zero, where  $J_\varepsilon(\mathcal{W}_{\varepsilon,\xi})$  is defined in (4-5) and  $\gamma$  is defined in (3-13).

*Proof.* The proof is based on a Taylor expansion in the neighborhood of  $\mathcal{W}_{\varepsilon,\xi}$  and the fact that  $\Phi_{\varepsilon,\xi}$  is orthogonal to the space  $K_{\varepsilon,\xi}$ . Then a straightforward computations yield

$$\begin{aligned} \tilde{J}_\varepsilon(\xi) - J_\varepsilon(\mathcal{W}_{\varepsilon,\xi}) &= \langle \mathcal{W}_{\varepsilon,\xi} + \Phi_{\varepsilon,\xi}, \Phi_{\varepsilon,\xi} \rangle_{\varepsilon, **} - \frac{1}{\varepsilon^n} \int_M (F(\mathcal{W}_{\varepsilon,\xi} + \Phi_{\varepsilon,\xi}) - F(\mathcal{W}_{\varepsilon,\xi})) \\ &= \frac{1}{\varepsilon^n} \int_M (f(\mathcal{W}_{\varepsilon,\xi} + \Phi_{\varepsilon,\xi}) - f(\mathcal{W}_{\varepsilon,\xi})) \Phi_{\varepsilon,\xi} \\ &\quad - \frac{1}{\varepsilon^n} \int_M (F(\mathcal{W}_{\varepsilon,\xi} + \Phi_{\varepsilon,\xi}) - F(\mathcal{W}_{\varepsilon,\xi}) - f(\mathcal{W}_{\varepsilon,\xi}) \Phi_{\varepsilon,\xi}) \\ &= \mathcal{O}(\|\Phi_{\varepsilon,\xi}\|_{\varepsilon, **}^2), \end{aligned}$$

where

$$F(u) := \frac{1}{p+1} (u^+)^{p+1}.$$

Then, using Proposition 3.4 we immediately get the desired result.  $\square$

**Lemma 4.4.** *Suppose that  $s \in (0, \frac{1}{2})$ ,  $n > 2s + 1$  and  $W$  the  $s$ -harmonic extension defined in (2-5). Then,*

$$(4-21) \quad \int_{\mathbb{R}_+^{n+1}} x_N^{2-2s} |\nabla W|^2 dx dx_N = \frac{4}{1+2s} \int_{\mathbb{R}_+^{n+1}} x_N^{2-2s} |\nabla_x W|^2 dx dx_N,$$

$$(4-22) \quad = \frac{1-2s}{2} \int_{\mathbb{R}_+^{n+1}} x_N^{-2s} W^2 dx dx_N < \infty.$$

*Proof.* We refer to Lemma 6.3 in [11] and Lemma 7.2 in [27] for the proof.  $\square$

As a consequence of the above lemmas, we have the validity of the following  $C^0$ -estimate.

**Proposition 4.5.** *We suppose that  $H = 0$  if  $s \in [\frac{1}{2}, 1)$  for  $\varepsilon > 0$  sufficiently small (which is the case when (1-21) holds). We have the validity of the following expansion for  $\tilde{J}_\varepsilon$ :*

$$(4-23) \quad \tilde{J}_\varepsilon(\xi) = \begin{cases} \tilde{C} - \varepsilon \tilde{d}_2 H(\xi) + o(\varepsilon) & \text{if } 0 < s < \frac{1}{2}, \\ \tilde{C} - \frac{1}{6} \varepsilon^2 [(\tilde{d} + \tilde{d}_1 \tilde{C}_{n,s}^2) R_g(\xi) + \tilde{d}_1 \tilde{C}_{n,s}^3 \|\pi\|^2(\xi)] + o(\varepsilon^2) & \text{if } \frac{1}{2} \leq s < 1, \end{cases}$$

uniformly for  $\xi \in M$  as  $\varepsilon$  goes to zero.

*Proof.* It follows directly from Lemmas 4.2, 4.3 and 4.4.  $\square$

**4B.  $C^1$ -estimates of the energy.** The aim is to improve Proposition 4.5 by showing that the  $o(1)$ -terms go to 0 in  $C^1$ -sense.

**Proposition 4.6.** *Estimate (4-23) is valid  $C^1$ -uniformly for  $\xi_0 \in M$ . Precisely, the following holds for each fixed point  $\xi_0 \in M$ . Suppose that  $y \in \mathbb{R}^n$  is a point near the origin. Under the assumption in Proposition 4.5, we have*

$$(4-24) \quad \begin{aligned} \frac{\partial}{\partial y_k} \tilde{J}_\varepsilon(\xi)(\exp_{\xi_0}(y))|_{y=0} &= \frac{\partial}{\partial y_k} (J_\varepsilon(\mathcal{W}_{\varepsilon,\xi} + \Phi_{\varepsilon,\xi}))|_{y=0} \\ &= \frac{\partial}{\partial y_k} (J_\varepsilon(\mathcal{W}_{\varepsilon,\xi}))|_{y=0} + o(\varepsilon^\nu) \end{aligned}$$

for each  $1 \leq k \leq n$ .

For the proof of Proposition 4.6, we first need to establish several preliminary lemmas. We fix  $\xi_0 \in M$  and set

$$\xi(y) = \exp_{\xi_0}(y) \quad \text{for } y \in B^n(0, 4r_0)$$

(recall that  $4r_0 > 0$  is chosen to be smaller than the injectivity radius of  $M$ ). Recall the definition of the cutoff function  $\chi_r$  in (2-24) and observe that any point  $z \in X$  located sufficiently close to  $\xi_0 \in M$  can be written as  $z = (\xi(x), x_N)$  for some  $x \in B^n(0, 2r_0)$  and  $x_N \in (0, r_0)$ , The first key result in the proof of Proposition 4.6 is:

**Lemma 4.7.** *For any  $1 \leq k \leq n$ , we have*

$$(4-25) \quad \begin{aligned} \frac{\partial}{\partial y_k} \mathcal{W}_{\varepsilon,\xi(y)} \Big|_{y=0} (\exp_{\xi_0}(x), x_N) \\ = \frac{1}{\varepsilon} \chi_r(\varepsilon x, \varepsilon x_N) \sum_{j=1}^N \left[ \partial_j W(x, x_N) \frac{\partial \mathcal{K}_j}{\partial y_k}(0, \varepsilon x) \right] \\ + \mathcal{O} \left( \varepsilon^{n-2s} \frac{|\nabla \chi_r|(|(x-y, x_N)|)}{|(x-y, x_N)|^{N-2s}} \right). \end{aligned}$$

Moreover, for any  $z$  near the point  $\xi_0$  and  $1 \leq i \leq n$ , it holds

$$(4-26) \quad \frac{\partial}{\partial y_k} \mathcal{Z}_{\varepsilon, \xi(y)} \Big|_{y=0} (\exp_{\xi_0}(x), x_N) \\ = \frac{1}{\varepsilon} \chi_r(\varepsilon x, \varepsilon x_N) \sum_{j=1}^N \left[ \partial_j Z_i(x, x_N) \frac{\partial \mathcal{K}_j}{\partial y_k}(0, \varepsilon x) \right] \\ + \mathcal{O} \left( \varepsilon^{n-2s} \frac{|\nabla \chi_r|(|(x-y, x_N)|)}{|(x-y, x_N)|^{N-2s}} \right),$$

uniformly with respect to  $\xi$  as  $\varepsilon$  goes to zero.

*Proof.* Let  $\xi_0 \in M$  be fixed, define

$$\xi = \xi(y) = \exp_{\xi_0}(y), \quad y \in B^n(0, 4r_0),$$

and set

$$\mathcal{K}(y, x) = \exp_{\xi(y)}^{-1}(\xi(x)) = (\mathcal{K}_1(y, x), \dots, \mathcal{K}_n(y, x)) \in \mathbb{R}^n.$$

Using the chain rule and [Lemma A.2](#), a straightforward computations yield

$$(4-27) \quad \frac{\partial}{\partial y_k} \mathcal{W}_{\varepsilon, \xi(y)}(z) = \chi_r(d((\exp_{\xi(y)}(x), x_N), \xi(y))) \\ \sum_{j=1}^N \left[ \partial_j W_\varepsilon(\mathcal{K}(y, x), x_N) \frac{\partial \mathcal{K}_j}{\partial y_k}(y, \xi^{-1}(\exp_{\xi(y)}(x))) \right] \\ + \mathcal{O} \left( \varepsilon^{n-2s} \frac{|\nabla \chi_r|(|(x, x_N)|)}{|(x, x_N)|^{N-2s}} \right) \\ = \frac{1}{\varepsilon} \chi_r(d((\exp_{\xi(y)}(\varepsilon x), \varepsilon x_N), \xi(y))) \\ \sum_{j=1}^N \left[ \partial_j W(\mathcal{K}(y, x), x_N) \frac{\partial \mathcal{K}_j}{\partial y_k}(y, \xi^{-1}(\exp_{\xi(y)}(\varepsilon x))) \right] \\ + \mathcal{O} \left( \varepsilon^{n-2s} \frac{|\nabla \chi_r|(|(x, x_N)|)}{|(x, x_N)|^{N-2s}} \right).$$

Taking  $y = 0$  on the both sides of (4-27), we get

$$\frac{\partial}{\partial y_k} \mathcal{W}_{\varepsilon, \xi(y)} \Big|_{y=0} (\exp_{\xi_0}(x), x_N) \\ = \frac{1}{\varepsilon} \chi_r(\varepsilon x, \varepsilon x_N) \sum_{j=1}^N \left[ \partial_j W(x, x_N) \frac{\partial \mathcal{K}_j}{\partial y_k}(0, \varepsilon x) \right] + \mathcal{O} \left( \varepsilon^{n-2s} \frac{|\nabla \chi_r|(|(x, x_N)|)}{|(x, x_N)|^{N-2s}} \right).$$

This proves the first identity (4-25). Reasoning similarly, we prove the second identity (4-26).  $\square$

Let  $\Phi_{\varepsilon,\xi}$  be the solution of (2-31) given by Proposition 3.4. Then for some constants  $c_\varepsilon^l \in \mathbb{R}$ ,  $1 \leq l \leq n$ , we have

$$(4-28) \quad \Phi_{\varepsilon,\xi} = -\mathcal{W}_{\varepsilon,\xi} + i^*(i(f(\mathcal{W}_{\varepsilon,\xi} + \Phi_{\varepsilon,\xi}))) + \sum_{l=1}^n c_\varepsilon^l \mathcal{Z}_{\varepsilon,\xi}^l.$$

We next have the following result which will be crucial in the proofs of Lemma 4.1 and Proposition 4.6.

**Lemma 4.8.** *The constants  $c_\varepsilon^l$ ,  $1 \leq l \leq n$ , defined in (4-28) satisfy*

$$(4-29) \quad c_\varepsilon^l = \mathcal{O}(\varepsilon^\gamma) \quad \text{for all } 1 \leq l \leq n.$$

*Proof.* Let  $\Phi_{\varepsilon,\xi(y)} \in K_{\varepsilon,\xi(y)}^\perp$  be given by (4-28) and let  $l \in \{1, \dots, n\}$ , we clearly have that

$$(4-30) \quad \begin{aligned} J'_\varepsilon(\mathcal{W}_{\varepsilon,\xi(y)} + \Phi_{\varepsilon,\xi(y)}) \mathcal{Z}_{\varepsilon,\xi(y)}^l &= \langle \mathcal{W}_{\varepsilon,\xi}, \mathcal{Z}_{\varepsilon,\xi}^l \rangle_{\varepsilon,**} - \frac{1}{\varepsilon^n} \int_M f(\mathcal{W}_{\varepsilon,\xi} + \Phi_{\varepsilon,\xi}) \mathcal{Z}_{\varepsilon,\xi}^l \\ &= \left( \langle \mathcal{Z}_{\varepsilon,\xi}^l, \mathcal{W}_{\varepsilon,\xi} \rangle_{\varepsilon,**} - \frac{1}{\varepsilon^n} \int_M f(\mathcal{W}_{\varepsilon,\xi}) \mathcal{Z}_{\varepsilon,\xi}^l \right) \\ &\quad + \left( \frac{1}{\varepsilon^n} \int_M (f(\mathcal{W}_{\varepsilon,\xi}) - f(\mathcal{W}_{\varepsilon,\xi} + \Phi_{\varepsilon,\xi})) \mathcal{Z}_{\varepsilon,\xi}^l \right) \\ &= I_1 + I_2. \end{aligned}$$

We first estimate  $I_1$  in (4-30). Replacing  $\Phi$  by  $\mathcal{Z}_{\varepsilon,\xi}^l$  in the proof of Lemma 3.2 and using the fact that  $\|\mathcal{Z}_{\varepsilon,\xi}^l\|_{\varepsilon,**} = \mathcal{O}(1)$ , we get

$$\langle \mathcal{Z}_{\varepsilon,\xi}^l, \mathcal{W}_{\varepsilon,\xi} \rangle_{\varepsilon,**} - \frac{1}{\varepsilon^n} \int_M (f(\mathcal{W}_{\varepsilon,\xi})) \mathcal{Z}_{\varepsilon,\xi}^l = \mathcal{O}(\varepsilon^\gamma).$$

Now, to estimate  $I_2$  we use the mean value theorem. We get, for some  $\tau \in [0, 1]$ , that

$$\begin{aligned} &\left| \frac{1}{\varepsilon^n} \int_M (f(\mathcal{W}_{\varepsilon,\xi}) - f(\mathcal{W}_{\varepsilon,\xi} + \Phi_{\varepsilon,\xi})) \mathcal{Z}_{\varepsilon,\xi}^l \right| \\ &= \left| \frac{1}{\varepsilon^n} \int_M f'(\mathcal{W}_{\varepsilon,\xi} + \tau \Phi_{\varepsilon,\xi}) \Phi_{\varepsilon,\xi} \mathcal{Z}_{\varepsilon,\xi}^l \right| \\ &\leq c \frac{1}{\varepsilon^n} \int_M |\mathcal{W}_{\varepsilon,\xi}|^{p-1} |\Phi_{\varepsilon,\xi}| |\mathcal{Z}_{\varepsilon,\xi}^l| + c \frac{1}{\varepsilon^n} \int_M |\Phi_{\varepsilon,\xi}|^p |\mathcal{Z}_{\varepsilon,\xi}^l| \\ &\leq c \|\Phi_{\varepsilon,\xi}\|_{\varepsilon,**} \|\mathcal{Z}_{\varepsilon,\xi}^l\|_{\varepsilon,**} + \|\Phi_{\varepsilon,\xi}\|_{\varepsilon,**}^p \|\mathcal{Z}_{\varepsilon,\xi}^l\|_{\varepsilon,**} = \mathcal{O}(\varepsilon^\gamma). \end{aligned}$$

Combining the two above estimates, it follows that

$$(4-31) \quad J'_\varepsilon(\mathcal{W}_{\varepsilon,\xi(y)} + \Phi_{\varepsilon,\xi(y)}) \mathcal{Z}_{\varepsilon,\xi(y)}^k = \mathcal{O}(\varepsilon^\gamma).$$

On the other hand, using (3-10) and (2-31), we conclude that

$$\begin{aligned}
 (4-32) \quad J'_\varepsilon(\mathcal{W}_{\varepsilon,\xi}(y) + \Phi_{\varepsilon,\xi}(y))\mathcal{Z}_{\varepsilon,\xi}^k &= \sum_{l=1}^n c_\varepsilon^l \langle \mathcal{Z}_{\varepsilon_m, \xi_m}^l, \mathcal{Z}_{\varepsilon_m, \xi_m}^k \rangle_\varepsilon \\
 &= \sum_{l=1}^n c_\varepsilon^l (\delta_{kl} + o(1)) \\
 &= c_\varepsilon^l \langle \mathcal{Z}_{\varepsilon,\xi}^l, \mathcal{Z}_{\varepsilon,\xi}^l \rangle_{\varepsilon, **} + \sum_{l \neq k} c_\varepsilon^k \langle \mathcal{Z}_{\varepsilon,\xi}^k, \mathcal{Z}_{\varepsilon,\xi}^l \rangle_{\varepsilon, **} \\
 &= \mathcal{O}(\varepsilon^\gamma).
 \end{aligned}$$

Using (4-31) and (4-32), the result follows at once.  $\square$

**Lemma 4.9.** *There exist  $\varepsilon_0 > 0$  and  $c > 0$  such that for any  $\xi \in M$  and for any  $\varepsilon \in (0, \varepsilon_0)$ , we have*

$$\|\mathcal{Z}_{\varepsilon,\xi}^l - i^*(i(f'(\mathcal{W}_{\varepsilon,\xi}(y))\mathcal{Z}_{\varepsilon,\xi}^l(y)))\|_{\varepsilon, **} \leq c\varepsilon^\gamma, \quad \left\| \frac{1}{\varepsilon} \mathcal{Z}_{\varepsilon,\xi}^l + \left( \frac{\partial}{\partial y_l} \mathcal{W}_{\varepsilon,\xi}(y) \right) \Big|_{y=0} \right\|_{\varepsilon, **} \leq c\varepsilon.$$

*Proof.* The proof of the first estimate follows the same arguments as the proof of Lemma 3.2. To prove the second estimate, it is convenient to write

$$\begin{aligned}
 &\left\| \frac{1}{\varepsilon} \mathcal{Z}_{\varepsilon,\xi}^l + \left( \frac{\partial}{\partial y_l} \mathcal{W}_{\varepsilon,\xi}(y) \right) \Big|_{y=0} \right\|_{\varepsilon, **}^2 \\
 &= \frac{1}{\varepsilon^{n-2s}} \kappa_s \int_X \left( \rho^{1-2s} \left| \nabla \left( \frac{1}{\varepsilon} \mathcal{Z}_{\varepsilon,\xi}^l + \left( \frac{\partial}{\partial y_l} \mathcal{W}_{\varepsilon,\xi}(y) \right) \Big|_{y=0} \right) \right|_{\bar{g}}^2 \right. \\
 &\quad \left. + E(\rho) \left( \frac{1}{\varepsilon} \mathcal{Z}_{\varepsilon,\xi}^l + \left( \frac{\partial}{\partial y_l} \mathcal{W}_{\varepsilon,\xi}(y) \right) \Big|_{y=0} \right)^2 \right) d\text{vol}_{\bar{g}} \\
 &\quad + \frac{1}{\varepsilon^n} \int_M \left( \frac{1}{\varepsilon} \mathcal{Z}_{\varepsilon,\xi}^l + \left( \frac{\partial}{\partial y_l} \mathcal{W}_{\varepsilon,\xi}(y) \right) \Big|_{y=0} \right)^2 d\text{vol}_g \\
 &= \Theta_1 + \Theta_2 + \Theta_3 \quad \text{for any } l = 1, \dots, n,
 \end{aligned}$$

where we have denoted by  $\Theta_1$ ,  $\Theta_2$  and  $\Theta_3$  respectively the first, second and third term in the right hand side of the above equality. To estimate  $\Theta_1$ , we write

$$\begin{aligned}
 (4-33) \quad \Theta_1 &= \kappa_s \int_{B(0,r/\varepsilon)} x_N^{1-2s} |\bar{g}_{\xi(y)}(\varepsilon x, \varepsilon x_N)|^{\frac{1}{2}} \\
 &\quad \left[ \bar{g}_{\xi(y)}^{-ij}(\varepsilon x, \varepsilon x_N) \partial_i \left( \frac{1}{\varepsilon} \mathcal{Z}_{\varepsilon,\xi}^l + \left( \frac{\partial}{\partial y_l} \mathcal{W}_{\varepsilon,\xi}(y) \right) \Big|_{y=0} \right) \right. \\
 &\quad \cdot \partial_j \left( \frac{1}{\varepsilon} \mathcal{Z}_{\varepsilon,\xi}^l + \left( \frac{\partial}{\partial y_l} \mathcal{W}_{\varepsilon,\xi}(y) \right) \Big|_{y=0} \right) \\
 &\quad \left. + \left( \partial_N \left( \frac{1}{\varepsilon} \mathcal{Z}_{\varepsilon,\xi}^l + \left( \frac{\partial}{\partial y_l} \mathcal{W}_{\varepsilon,\xi}(y) \right) \Big|_{y=0} \right) \right)^2 \right] dx dx_N,
 \end{aligned}$$



where summation over repeated indices is understood. Using [Lemma 4.7](#) we obtain

$$\begin{aligned}
& \frac{1}{\varepsilon} \mathcal{Z}_{\varepsilon, \xi}^l + \frac{1}{\varepsilon} \left( \frac{\partial}{\partial y_l} \mathcal{W}_{\varepsilon, \xi}(y) \right) \Big|_{y=0} \\
&= \frac{1}{\varepsilon} \chi_r(\varepsilon x, \varepsilon x_N) \sum_{k=1}^n \left[ \partial_k W(x, x_N) \frac{\partial \mathcal{K}_k}{\partial y_l}(0, \varepsilon x) \right] \\
&\quad + \frac{1}{\varepsilon} \chi_r(\varepsilon x, \varepsilon x_N) Z_l(x, x_N) + \mathcal{O} \left( \varepsilon^{n-2s} \frac{|\nabla \chi_r|(|(x-y, x_N)|)}{|(x-y, x_N)|^{N-2s}} \right) \\
&= \frac{1}{\varepsilon} \chi_r(\varepsilon x, \varepsilon x_N) Z_l(x, x_N) \left[ \frac{\partial \mathcal{K}_l}{\partial y_l}(0, \varepsilon x) + 1 \right] \\
&\quad + \frac{1}{\varepsilon} \sum_{k=1, k \neq l}^n \chi_r(\varepsilon x, \varepsilon x_N) Z_k(x, x_N) \frac{\partial \mathcal{K}_k}{\partial y_l}(0, \varepsilon x) + \mathcal{O} \left( \varepsilon^{n-2s} \frac{|\nabla \chi_r|(|(x-y, x_N)|)}{|(x-y, x_N)|^{N-2s}} \right).
\end{aligned}$$

This implies that

$$\begin{aligned}
& \partial_i \left( \frac{1}{\varepsilon} \mathcal{Z}_{\varepsilon, \xi}^l + \left( \frac{\partial}{\partial y_l} \mathcal{W}_{\varepsilon, \xi}(y) \right) \Big|_{y=0} \right) \\
&= \frac{1}{\varepsilon} \chi_r(\varepsilon x, \varepsilon x_N) \partial_i Z_l(x, x_N) \left[ \frac{\partial \mathcal{K}_l}{\partial y_l}(0, \varepsilon x) + 1 \right] \\
&\quad + \partial_i \chi_r(\varepsilon x, \varepsilon x_N) Z_l(x, x_N) \left[ \frac{\partial \mathcal{K}_l}{\partial y_l}(0, \varepsilon x) + 1 \right] \\
&\quad + \frac{1}{\varepsilon} \chi_r(\varepsilon x, \varepsilon x_N) Z_l(x, x_N) \partial_i \left( \frac{\partial \mathcal{K}_l}{\partial y_l}(0, \varepsilon x) \right) \\
&\quad + \frac{1}{\varepsilon} \sum_{k=1, k \neq l}^n \chi_r(\varepsilon x, \varepsilon x_N) \partial_i Z_k(x, x_N) \frac{\partial \mathcal{K}_k}{\partial y_l}(0, \varepsilon x) \\
&\quad + \sum_{k=1, k \neq l}^n \partial_i \chi_r(\varepsilon x, \varepsilon x_N) Z_k(x, x_N) \frac{\partial \mathcal{K}_k}{\partial y_l}(0, \varepsilon x) \\
&\quad + \frac{1}{\varepsilon} \sum_{k=1, k \neq l}^n \chi_r(\varepsilon x, \varepsilon x_N) Z_k(x, x_N) \partial_i \left( \frac{\partial \mathcal{K}_k}{\partial y_l}(0, \varepsilon x) \right) \\
&\quad + \mathcal{O} \left( \varepsilon^{n-2s} \partial_i \frac{|\nabla \chi_r|(|(x-y, x_N)|)}{|(x-y, x_N)|^{N-2s}} \right).
\end{aligned}$$

Recalling the definition of the cutoff function  $\chi_r$  defined above, we obtain

$$(4-34) \quad \Theta_1 \leq c \sum_{h=1}^7 \Theta_{1h},$$

where the quantities  $\Theta_{1h}$ 's are given by

$$\Theta_{11} = \frac{1}{\varepsilon^2} \kappa_s \int_{B_{2r_0/\varepsilon}^+} x_N^{1-2s} \left\{ |\partial_i Z_l(x, x_N)|^2 + |\partial_N Z_l(x, x_N)|^2 \right\} \left| \frac{\partial \mathcal{K}_l}{\partial y_l}(0, \varepsilon x) + 1 \right|^2,$$

$$\Theta_{12} = \kappa_s \int_{B_{2r_0/\varepsilon}^+} x_N^{1-2s} \left\{ |\partial_i \chi_r(\varepsilon x, \varepsilon x_N) Z_l(x, x_N)|^2 + |\partial_N \chi_r(\varepsilon x, \varepsilon x_N) Z_l(x, x_N)|^2 \right\} \cdot \left| \frac{\partial \mathcal{K}_l}{\partial y_l}(0, \varepsilon x) + 1 \right|^2,$$

$$\Theta_{13} = \frac{1}{\varepsilon^2} \kappa_s \int_{B_{2r_0/\varepsilon}^+} x_N^{1-2s} \left\{ \left| \partial_i \left( \frac{\partial \mathcal{K}_l}{\partial y_l}(0, \varepsilon x) \right) \right|^2 + \left| \partial_N \left( \frac{\partial \mathcal{K}_l}{\partial y_l}(0, \varepsilon x) \right) \right|^2 \right\} \cdot |\chi_r(\varepsilon x, \varepsilon x_N) Z_l(x, x_N)|^2,$$

$$\Theta_{14} = \frac{1}{\varepsilon^2} \sum_{k=1, k \neq l}^n \kappa_s \int_{B_{2r_0/\varepsilon}^+} x_N^{1-2s} \left\{ |\partial_i Z_k(x, x_N)|^2 + |\partial_N Z_k(x, x_N)|^2 \right\} \left| \frac{\partial \mathcal{K}_k}{\partial y_l}(0, \varepsilon x) \right|^2,$$

$$\Theta_{15} = \sum_{k=1, k \neq l}^n \kappa_s \int_{B_{2r_0/\varepsilon}^+} x_N^{1-2s} \left\{ |\partial_i \chi_r(\varepsilon x, \varepsilon x_N) Z_k(x, x_N)|^2 + |\partial_N \chi_r(\varepsilon x, \varepsilon x_N) Z_k(x, x_N)|^2 \right\} \left| \frac{\partial \mathcal{K}_k}{\partial y_l}(0, \varepsilon x) \right|^2,$$

$$\Theta_{16} = \frac{1}{\varepsilon^2} \sum_{k=1, k \neq l}^n \kappa_s \int_{B_{2r_0/\varepsilon}^+} x_N^{1-2s} \left\{ \left| \partial_i \left( \frac{\partial \mathcal{K}_k}{\partial y_l}(0, \varepsilon x) \right) \right|^2 + \left| \partial_N \left( \frac{\partial \mathcal{K}_k}{\partial y_l}(0, \varepsilon x) \right) \right|^2 \right\} \cdot |\chi_r(\varepsilon x, \varepsilon x_N) Z_k(x, x_N)|^2,$$

$$\Theta_{17} = \kappa_s \int_{B_{2r_0/\varepsilon}^+} x_N^{1-2s} \left\{ \left( \varepsilon^{n-2s} \partial_i \frac{|\nabla \chi_r(|(x-y, x_N)|)|}{|(x-y, x_N)|^{N-2s}} \right)^2 + \left( \varepsilon^{n-2s} \partial_N \frac{|\nabla \chi_r(|(x-y, x_N)|)|}{|(x-y, x_N)|^{N-2s}} \right)^2 \right\}.$$

On the other hand, using (6.12) of [32] (see also [13]), we have that

$$(4-35) \quad \frac{\partial \mathcal{K}_k}{\partial y_l}(y, \xi^{-1}(\exp_{\xi(y)})(\varepsilon x)) \Big|_{y=0} = \frac{\partial \mathcal{K}_k}{\partial y_l}(0, \varepsilon x) = -\delta_{kl} + \mathcal{O}(\varepsilon^2 |x|^2).$$

Then by (4-34) we get

$$\Theta_1 \leq c\varepsilon^2.$$

Arguing similarly, we easily obtain

$$\begin{aligned}
(4-36) \quad \Theta_2 &= \varepsilon^{1+2s} \kappa_s \int_{B_{2r_0/\varepsilon}^+} E(\varepsilon x_N) \left\{ \frac{1}{\varepsilon} \chi_r(\varepsilon x, \varepsilon x_N) Z_l(x, x_N) \left[ \frac{\partial \mathcal{K}_l}{\partial y_l}(0, \varepsilon x) + 1 \right] \right. \\
&\quad + \sum_{k=1, k \neq l}^n \chi_r(\varepsilon x, \varepsilon x_N) Z_k(x, x_N) \frac{\partial \mathcal{K}_k}{\partial y_l}(0, \varepsilon x) \\
&\quad \left. + \mathcal{O} \left( \varepsilon^{n-2s} \frac{|\nabla \chi_r|(|(x-y, x_N)|)}{|(x-y, x_N)|^{N-2s}} \right) \right\}^2 \\
&\quad \cdot |\bar{g}_{\xi(y)}(\varepsilon x, \varepsilon x_N)|^{\frac{1}{2}} dx dx_N \\
&\leq c\varepsilon^2
\end{aligned}$$

and

$$\begin{aligned}
(4-37) \quad \Theta_3 &= \int_{B_{2r_0/\varepsilon}} \left( \frac{1}{\varepsilon} Z_{\varepsilon, \xi}^l + \left( \frac{\partial}{\partial y_l} \mathcal{W}_{\varepsilon, \xi(y)} \right) \Big|_{y=0} \right)^2 |g_{\xi(y)}(\varepsilon x, \varepsilon x_N)|^{\frac{1}{2}} dx \\
&= \int_{B_{2r_0/\varepsilon}} \left[ \frac{1}{\varepsilon} \chi_r(\varepsilon x, \varepsilon x_N) Z_l(x, x_N) \left[ \frac{\partial \mathcal{K}_l}{\partial y_l}(0, \varepsilon x) + 1 \right] \right. \\
&\quad + \sum_{k=1, k \neq l}^n \chi_r(\varepsilon x, \varepsilon x_N) Z_k(x, x_N) \frac{\partial \mathcal{K}_k}{\partial y_l}(0, \varepsilon x) \\
&\quad \left. + \mathcal{O} \left( \varepsilon^{n-2s} \frac{|\nabla \chi_r|(|(x-y, x_N)|)}{|(x-y, x_N)|^{N-2s}} \right) \right]^2 |g_{\xi(y)}(\varepsilon x, \varepsilon x_N)|^{\frac{1}{2}} dx \\
&\leq c\varepsilon^2.
\end{aligned}$$

This prove the desired estimate.  $\square$

We go back now to the proof of [Proposition 4.6](#). For simplicity, we will use the notation

$$(\chi_r \partial_k W_\varepsilon)(z) = \chi_r(|(x, x_N)|) W_\varepsilon(x, x_N)$$

for  $z = (\xi(x), x_N) \in X$  near  $\xi_0 \in M$ . We may assume that the domain of these functions is the Euclidean space  $\mathbb{R}_+^{n+1}$ .

By the previous lemma, we have

$$\begin{aligned}
&\frac{\partial}{\partial y_k} J_\varepsilon(\mathcal{W}_{\varepsilon, \xi(y)} + \Phi_{\varepsilon, \xi(y)}) - \frac{\partial}{\partial y_k} J_\varepsilon(\mathcal{W}_{\varepsilon, \xi(y)}) \\
&= J'_\varepsilon(\mathcal{W}_{\varepsilon, \xi(y)} + \Phi_{\varepsilon, \xi(y)})(\partial_{y_k} \mathcal{W}_{\varepsilon, \xi(y)} + \partial_{y_k} \Phi_{\varepsilon, \xi(y)}) - J'_\varepsilon(\mathcal{W}_{\varepsilon, \xi(y)})(\partial_k \mathcal{W}_{\varepsilon, \xi(y)}) \\
&= J'_\varepsilon(\mathcal{W}_{\varepsilon, \xi(y)} + \Phi_{\varepsilon, \xi(y)})[\partial_{y_k} \Phi_{\varepsilon, \xi(y)}] + [J'_\varepsilon(\mathcal{W}_{\varepsilon, \xi(y)} + \Phi_{\varepsilon, \xi(y)}) - J'_\varepsilon(\mathcal{W}_{\varepsilon, \xi(y)})][\partial_k \mathcal{W}_{\varepsilon, \xi(y)}] \\
&= J_1 + J_2,
\end{aligned}$$

where we have set

$$\begin{aligned}
J_1 &:= J'_\varepsilon(\mathcal{W}_{\varepsilon, \xi(y)} + \Phi_{\varepsilon, \xi(y)})[\partial_{y_k} \Phi_{\varepsilon, \xi(y)}], \\
J_2 &:= [J'_\varepsilon(\mathcal{W}_{\varepsilon, \xi(y)} + \Phi_{\varepsilon, \xi(y)}) - J'_\varepsilon(\mathcal{W}_{\varepsilon, \xi(y)})][\partial_k \mathcal{W}_{\varepsilon, \xi(y)}].
\end{aligned}$$

We first estimate the term  $J_1$ . Using [Lemma 4.8](#), [Proposition 3.4](#) and the fact that  $\|\partial_{y_k} \mathcal{Z}_{\varepsilon, \xi}^l\|_{\varepsilon, **} = \mathcal{O}(1)$ , we get

$$\begin{aligned}
(4-38) \quad J_1 &= J'_\varepsilon(\mathcal{W}_{\varepsilon, \xi(y)} + \Phi_{\varepsilon \xi(y)})[\partial_{y_k} \Phi_{\varepsilon, \xi(y)}] \\
&= \sum_{l=1}^n c_\varepsilon^l \langle \mathcal{Z}_{\varepsilon, \xi}^l, \partial_{y_k} \Phi_{\varepsilon, \xi(y)} \rangle_{\varepsilon, *} \\
&= - \sum_{l=1}^n c_\varepsilon^l \langle \partial_{y_k} \mathcal{Z}_{\varepsilon, \xi}^l, \Phi_{\varepsilon, \xi(y)} \rangle_{\varepsilon, *} \\
&\leq \sum_{l=1}^n |c_\varepsilon^l| |\langle \partial_{y_k} \mathcal{Z}_{\varepsilon, \xi}^l, \Phi_{\varepsilon, \xi(y)} \rangle_{\varepsilon, *}| \\
&\leq c \sum_{l=1}^n |c_\varepsilon^l| \|\partial_{y_k} \mathcal{Z}_{\varepsilon, \xi}^l\|_{\varepsilon, *} \|\Phi_{\varepsilon, \xi(y)}\|_{\varepsilon, *} = \mathcal{O}(\varepsilon^{2\gamma}).
\end{aligned}$$

Concerning the term  $J_2$ , we write

$$\begin{aligned}
J_2 &= [J'_\varepsilon(\mathcal{W}_{\varepsilon, \xi(y)} + \Phi_{\varepsilon, \xi(y)}) - J'_\varepsilon(\mathcal{W}_{\varepsilon, \xi(y)})][\partial_k \mathcal{W}_{\varepsilon, \xi(y)}] \\
&= \langle \Phi_{\varepsilon, \xi(y)}, \partial_k \mathcal{W}_{\varepsilon, \xi(y)} \rangle_{\varepsilon, *} - \frac{1}{\varepsilon^n} \int_M [f(\mathcal{W}_{\varepsilon, \xi(y)} + \Phi_{\varepsilon, \xi(y)}) - f(\mathcal{W}_{\varepsilon, \xi(y)})] \partial_k \mathcal{W}_{\varepsilon, \xi(y)} \\
&= \left\langle \Phi_{\varepsilon, \xi(y)} - i^*(i(f'(\mathcal{W}_{\varepsilon, \xi(y)}) \Phi_{\varepsilon, \xi(y)})), \partial_k \mathcal{W}_{\varepsilon, \xi(y)} + \frac{1}{\varepsilon} \mathcal{Z}_{\varepsilon, \xi(y)}^l \right\rangle_{\varepsilon, *} \\
&\quad - \frac{1}{\varepsilon^n} \int_M [f(\mathcal{W}_{\varepsilon, \xi(y)} + \Phi_{\varepsilon, \xi(y)}) - f(\mathcal{W}_{\varepsilon, \xi(y)}) - f'(\mathcal{W}_{\varepsilon, \xi(y)}) \Phi_{\varepsilon, \xi(y)}] \partial_k \mathcal{W}_{\varepsilon, \xi(y)} \\
&\quad - \frac{1}{\varepsilon^n} \langle \Phi_{\varepsilon, \xi(y)}, \mathcal{Z}_{\varepsilon, \xi(y)}^l - i^*(i(f'(\mathcal{W}_{\varepsilon, \xi(y)}) \mathcal{Z}_{\varepsilon, \xi(y)}^l)) \rangle_{\varepsilon, *} \\
&= J_{21} + J_{22} + J_{23}.
\end{aligned}$$

To estimate  $J_{21}$ , we use [\(3-20\)](#), [\(2-15\)](#) and [Lemma 4.9](#). We get

$$\begin{aligned}
(4-39) \quad |J_{21}| &\leq \|\Phi_{\varepsilon, \xi(y)} - i^*(i(f'(\mathcal{W}_{\varepsilon, \xi(y)}) \Phi_{\varepsilon, \xi(y)}))\|_{\varepsilon, *} \|\partial_k \mathcal{W}_{\varepsilon, \xi(y)} + \frac{1}{\varepsilon} \mathcal{Z}_{\varepsilon, \xi(y)}^l\|_{\varepsilon, *} \\
&\leq c\varepsilon \|\Phi_{\varepsilon, \xi(y)}\|_{\varepsilon, *} = \mathcal{O}(\varepsilon^{\gamma+1}).
\end{aligned}$$

Next, we compute the second term  $J_{22}$ , by [\(3-20\)](#), we obtain

$$(4-40) \quad |J_{22}| \leq c(\|\Phi_{\varepsilon, \xi(y)}\|_{\varepsilon, **}^2 + \|\Phi_{\varepsilon, \xi(y)}\|_{\varepsilon, *}^{p+1}) \|\partial_k \mathcal{W}_{\varepsilon, \xi(y)}\|_{\varepsilon, *} = \mathcal{O}(\varepsilon^{2\gamma})$$

We now estimate the second term  $J_{22}$ . For  $p \geq 2$ , we have that

$$(4-41) \quad |J_{22}| \leq c\|\Phi_{\varepsilon, \xi(y)}\|_{\varepsilon, **}^2 \|\partial_k \mathcal{W}_{\varepsilon, \xi(y)}\|_{\varepsilon, *} + \|\Phi_{\varepsilon, \xi(y)}\|_{\varepsilon, *}^p \|\partial_k \mathcal{W}_{\varepsilon, \xi(y)}\|_{\varepsilon, *}.$$

While, for  $1 < p < 2$ , we have that

$$(4-42) \quad \begin{aligned} |J_{22}| &\leq c \frac{1}{\varepsilon^n} \int_M \mathcal{W}_{\varepsilon, \xi(y)}^{p-2} \Phi_{\varepsilon, \xi(y)}^2 |\partial_k \mathcal{W}_{\varepsilon, \xi(y)}| \\ &\leq c \|\Phi_{\varepsilon, \xi(y)}\|_{\varepsilon, **}^2 \|\partial_k \mathcal{W}_{\varepsilon, \xi(y)}\|_{\varepsilon, *} \|\mathcal{W}_{\varepsilon, \xi(y)}\|_{\varepsilon, *}^{p-2}. \end{aligned}$$

Then, using (4-28), we conclude, for every  $p \in (1, 2_s^* - 1)$

$$|J_{22}| = \mathcal{O}(\varepsilon^{2\gamma}).$$

Finally, using (3-20) and Lemma 4.9, the last term  $J_{23}$  can be estimated as

$$|J_{23}| \leq \|\Phi_{\varepsilon, \xi(y)}\|_{\varepsilon, *} \|\mathcal{Z}_{\varepsilon, \xi(y)}^l - i^*(i(f'(\mathcal{W}_{\varepsilon, \xi(y)}))\mathcal{Z}_{\varepsilon, \xi(y)}^l)\|_{\varepsilon, *} = \mathcal{O}(\varepsilon^{2\gamma}).$$

Collecting the previous estimates, we deduce that

$$(4-43) \quad J_2 = \mathcal{O}(\varepsilon^{2\gamma}) + \mathcal{O}(\varepsilon^{\gamma+1}).$$

Combining (4-38) and (4-43), the result follows at once.

**Proposition 4.10.** *Define  $\xi(y) = \exp_\xi(y)$ ,  $y \in B^n(0, 4r_0)$ . It holds the following.*

- For  $0 < s < \frac{1}{2}$

$$(4-44) \quad \begin{aligned} \left( \frac{\partial}{\partial y_h} J_\varepsilon(\mathcal{W}_{\varepsilon, \xi}) \right)_{|y=0} \\ = -\varepsilon d_1 \left( \frac{\partial}{\partial y_k} H(\xi(y)) \right)_{|y=0} + \varepsilon d_2 \left( \frac{\partial}{\partial y_k} \pi_{ij}(\xi(y)) \right)_{|y=0} + o(\varepsilon). \end{aligned}$$

- For  $\frac{1}{2} \leq s < 1$

$$(4-45) \quad \begin{aligned} \left( \frac{\partial}{\partial y_h} J_\varepsilon(\mathcal{W}_{\varepsilon, \xi}) \right)_{|y=0} \\ = \frac{\varepsilon^2}{12} b_1 \left( \frac{\partial}{\partial y_m} R_{kl}(\xi(y)) \right)_{|y=0} - \frac{\varepsilon^2}{6} b_2 \left( \frac{\partial}{\partial y_m} R_{ikjl}(\xi(y)) \right)_{|y=0} \\ - \frac{\varepsilon^2}{2} b_3 \left( - \left( \frac{\partial}{\partial y_k} R_{NN}(\xi(y)) \right) + \left( \frac{\partial}{\partial y_k} \pi_{is}(\xi(y)) \right) \pi_{si} \right)_{|y=0} \\ + \varepsilon^2 b_4 \left( \left( \frac{\partial}{\partial y_k} R_{iNjN}(\xi(y)) \right) + 7 \left( \frac{\partial}{\partial y_k} \pi_{jh}(\xi(y)) \right) \pi_{hi}(\xi(y)) \right)_{|y=0} + o(\varepsilon^2) \end{aligned}$$

uniformly in  $\xi$  as  $\varepsilon$  goes to zero. Here the constants  $b_1, b_2, b_3, b_4, d_1$  and  $d_2$  are explicit constants given below.

*Proof.* We have

$$\begin{aligned}
& \frac{\partial}{\partial y_h} J_\varepsilon(\mathcal{W}_{\varepsilon,\xi}) \\
&= J'_\varepsilon(\mathcal{W}_{\varepsilon,\xi}) \left[ \frac{\partial}{\partial y_h} \mathcal{W}_{\varepsilon,\xi} \right] \\
&= \frac{1}{\varepsilon^{n-2s}} \kappa_s \int_X \left( \rho^{1-2s} \left( \nabla \mathcal{W}_{\varepsilon,\xi(y)}, \nabla \frac{\partial}{\partial y_h} \mathcal{W}_{\varepsilon,\xi(y)} \right)_{\bar{g}} + E(\rho) \mathcal{W}_{\varepsilon,\xi(y)} \frac{\partial}{\partial y_h} \mathcal{W}_{\varepsilon,\xi(y)} \right) d\text{vol}_{\bar{g}} \\
&\quad + \frac{1}{\varepsilon^n} \int_M \mathcal{W}_{\varepsilon,\xi(y)} \frac{\partial}{\partial y_h} \mathcal{W}_{\varepsilon,\xi(y)} - f(\mathcal{W}_{\varepsilon,\xi(y)}) \frac{\partial}{\partial y_h} \mathcal{W}_{\varepsilon,\xi(y)} d\text{vol}_g \\
&= \kappa_s \int_{B_{2r_0/\varepsilon}^+} x_N^{1-2s} \left\{ \bar{g}_{\xi(y)}^{-ij} (\varepsilon x, \varepsilon x_N) \partial_i \mathcal{W}_{\varepsilon,\xi(y)} \partial_j \left( \frac{\partial}{\partial y_h} \mathcal{W}_{\varepsilon,\xi(y)} \right) \right. \\
&\quad \left. + \partial_N \mathcal{W}_{\varepsilon,\xi(y)} \partial_N \left( \frac{\partial}{\partial y_h} \mathcal{W}_{\varepsilon,\xi(y)} \right) \right\} |\bar{g}_{\xi(y)}(\varepsilon x, \varepsilon x_N)|^{\frac{1}{2}} dx dx_N \\
&\quad + \varepsilon^{1+2s} \kappa_s \int_{B_{2r_0/\varepsilon}^+} E(\varepsilon \rho) \mathcal{W}_{\varepsilon,\xi(y)} \frac{\partial}{\partial y_h} \mathcal{W}_{\varepsilon,\xi(y)} |\bar{g}_{\xi(y)}(\varepsilon x, \varepsilon x_N)|^{\frac{1}{2}} dx dx_N \\
&\quad + \int_{B_{2r_0/\varepsilon}} \mathcal{W}_{\varepsilon,\xi(y)} \frac{\partial}{\partial y_h} \mathcal{W}_{\varepsilon,\xi(y)} |g_{\xi(y)}(\varepsilon x)|^{\frac{1}{2}} dx dx_N \\
&\quad - \int_{B_{2r_0/\varepsilon}} f(\mathcal{W}_{\varepsilon,\xi(y)}) \frac{\partial}{\partial y_h} \mathcal{W}_{\varepsilon,\xi(y)} |g_{\xi(y)}(\varepsilon x)|^{\frac{1}{2}} dx dx_N \\
&= \mathcal{J}_1 + \mathcal{J}_2 + \mathcal{J}_3 - \mathcal{J}_4.
\end{aligned}$$

Using Taylor's expansions, we get

$$\begin{aligned}
\sqrt{\det \bar{g}} &= \sqrt{\det g} \\
&= 1 - H x_N + \frac{1}{2} (H^2 - \|\pi\|^2 - R_{NN}) x_N^2 - H_{,k} x_k x_N - \frac{1}{6} R_{kl} x_k x_l - \frac{1}{12} R_{kl,m} x_k x_l x_m \\
&\quad + \frac{1}{2} (-H_{,kl} + \frac{1}{3} R_{iksl} \pi_{si}) x_k x_l x_N + \frac{1}{2} (-R_{NN,k} + \pi_{is,k} \pi_{si}) x_k x_N^2 \\
&\quad + \frac{1}{6} (-R_{NN,N} + 2(\pi_{is} R_{sNiN}) - 4H^3 + 12H(\pi_{is})^2 - 8\pi_{is} \pi_{sr} \pi_{ri}) x_N^3 \\
&\quad + \mathcal{O}(|(x, x_N)|^4),
\end{aligned}$$

and

$$\begin{aligned}
g_\xi^{ij} &= \bar{g}_\xi^{ij} \\
&= \delta_{ij} + 2\pi_{ij} x_N + \frac{1}{3} R_{ikjl} x_k x_l + 2\pi_{ij,k} x_k x_N + (3\pi_{ih} \pi_{hj} + R_{iNjN}) x_N^2 \\
&\quad + \frac{1}{6} R_{ikjl,m} x_k x_l x_m + (\pi_{ij,kl} + R_{jkhl} \pi_{hi}) x_k x_l x_N + (R_{iNjN,k} + 7\pi_{jh,k} \pi_{hi}) x_k x_N^2 \\
&\quad + \frac{1}{3} (R_{iNjN,N} + 10(\pi_{ih} R_{hNjN}) + 12\pi_{ih} \pi_{hr} \pi_{rj}) x_N^3 + \mathcal{O}(|(x, x_N)|^4).
\end{aligned}$$

• For  $0 < s < \frac{1}{2}$ , we first compute the term  $\mathcal{J}_1$ . Using [Lemma 4.7](#), we have

$$\begin{aligned}
(4-46) \quad \mathcal{J}_1 &= \kappa_s \int_{B_{2r_0/\varepsilon}^+} x_N^{1-2s} |\bar{g}_{\xi(y)}(\varepsilon x, \varepsilon x_N)|^{\frac{1}{2}} \\
&\quad \left\{ \bar{g}_{\xi(y)}^{-ij}(\varepsilon x, \varepsilon x_N) \partial_i \mathcal{W}_{\varepsilon, \xi(y)} \partial_j \left( \frac{\partial}{\partial y_h} \mathcal{W}_{\varepsilon, \xi(y)} \right) \right. \\
&\quad \left. + \partial_N \mathcal{W}_{\varepsilon, \xi(y)} \partial_N \left( \frac{\partial}{\partial y_h} \mathcal{W}_{\varepsilon, \xi(y)} \right) \right\} dx dx_N \\
&= -\varepsilon H_{,k} \kappa_s \sum_{e=1}^n \frac{\partial \mathcal{K}_e}{\partial y_h}(y, \xi(y)) \\
&\quad \int_{\mathbb{R}_+^{n+1}} x_N^{2-2s} x_k (\partial_i W \partial_{ie}^2 W + \partial_N W \partial_{Ne}^2 W) dx dx_N \\
&\quad + 2\varepsilon \pi_{ij,k} \kappa_s \sum_{e=1}^n \frac{\partial \mathcal{K}_e}{\partial y_h}(y, \xi(y)) \int_{\mathbb{R}_+^{n+1}} x_N^{2-2s} x_k \partial_i W \partial_{je}^2 W dx dx_N \\
&\quad + o(\varepsilon).
\end{aligned}$$

Similarly, we can estimate the second term  $\mathcal{J}_2$  as

$$\begin{aligned}
(4-47) \quad \mathcal{J}_2 &= \varepsilon^{1+2s} \kappa_s \int_{B_{2r_0/\varepsilon}^+} E(\varepsilon x_N) \mathcal{W}_{\varepsilon, \xi(y)} \frac{\partial}{\partial y_h} \mathcal{W}_{\varepsilon, \xi(y)} |\bar{g}_{\xi(y)}(\varepsilon x, \varepsilon x_N)|^{\frac{1}{2}} dx dx_N \\
&= \varepsilon^{1+2s} \kappa_s \int_{B_{2r_0/\varepsilon}^+} E(\varepsilon x_N) W \chi(\varepsilon x, \varepsilon x_N) \\
&\quad \cdot \left( \frac{1}{\varepsilon} \chi_r(\varepsilon x, \varepsilon x_N) \sum_{e=1}^n \left[ \partial_e W(x, x_N) \frac{\partial \mathcal{K}_e}{\partial y_h}(y, \xi^{-1}(\exp_{\xi(y)})(\varepsilon x)) \right] \right. \\
&\quad \left. + \mathcal{O} \left( \frac{\varepsilon^{n-2s} |\nabla \chi_r| (|(x-y, x_N)|)}{|(x-y, x_N)|^{N-2s}} \right) \right) \\
&\quad \cdot |\bar{g}_{\xi(y)}(\varepsilon x, \varepsilon x_N)|^{\frac{1}{2}} dx dx_N \\
&= o(\varepsilon).
\end{aligned}$$

On the other hand, similar arguments yield

$$\begin{aligned}
(4-48) \quad \mathcal{J}_3 &= \int_{B_{2r_0/\varepsilon}} \mathcal{W}_{\varepsilon, \xi(y)} \frac{\partial}{\partial y_h} \mathcal{W}_{\varepsilon, \xi(y)} |g_{\xi(y)}(\varepsilon x, \varepsilon x_N)|^{\frac{1}{2}} dx \\
&= \int_{B_{2r_0/\varepsilon}} \omega \chi_{r/\varepsilon} \left( \frac{1}{\varepsilon} \chi_{r/\varepsilon} \sum_{e=1}^n \left[ \partial_e \omega \frac{\partial \mathcal{K}_e}{\partial y_h}(y, \xi^{-1}(\exp_{\xi(y)})(\varepsilon x)) \right] \right. \\
&\quad \left. + \mathcal{O} \left( \frac{\varepsilon^{n-2s} |\nabla \chi_r| (|(x-y)|)}{|(x-y)|^{N-2s}} \right) \right) |g_{\xi(y)}(\varepsilon x)|^{\frac{1}{2}} dx \\
&= o(\varepsilon).
\end{aligned}$$

Finally

$$\begin{aligned}
(4-49) \quad \mathcal{J}_4 &= \int_{B_{2r_0/\varepsilon}} f(\mathcal{W}_{\varepsilon, \xi(y)}) \frac{\partial}{\partial y_h} \mathcal{W}_{\varepsilon, \xi(y)} |g_{\xi(y)}(\varepsilon x)|^{\frac{1}{2}} dx \\
&= \int_{B_{2r_0/\varepsilon}} f(\omega \chi_{r/\varepsilon}) \left( \frac{1}{\varepsilon} \chi_{r/\varepsilon} \sum_{e=1}^n \left[ \partial_e \omega \frac{\partial \mathcal{K}_e}{\partial y_h} (y, \xi^{-1}(\exp_{\xi(y)})(\varepsilon x)) \right] \right. \\
&\quad \left. + \mathcal{O} \left( \varepsilon^{n-2s} \frac{|\nabla \chi_r|(|(x-y)|)}{|(x-y)|^{N-2s}} \right) \right) |g_{\xi(y)}(\varepsilon x)|^{\frac{1}{2}} dx \\
&= o(\varepsilon).
\end{aligned}$$

Using (4-46)–(4-49), we deduce that

$$\begin{aligned}
&\frac{\partial}{\partial y_h} J_\varepsilon(\mathcal{W}_{\varepsilon, \xi}) \\
&= -\varepsilon H_{,k} \kappa_s \sum_{e=1}^n \frac{\partial \mathcal{K}_e}{\partial y_h} (y, \xi(y)) \int_{\mathbb{R}_+^{n+1}} x_N^{2-2s} x_k (\partial_i W \partial_{i_e}^2 W + \partial_N W \partial_{N_e}^2 W) dx dx_N \\
&\quad + 2\varepsilon \pi_{ij,k} \kappa_s \sum_{e=1}^n \frac{\partial \mathcal{K}_e}{\partial y_h} (y, \xi(y)) \int_{\mathbb{R}_+^{n+1}} x_N^{2-2s} x_k \partial_i W \partial_{j_e}^2 W dx dx_N \\
&\quad + o(\varepsilon).
\end{aligned}$$

Then

$$\begin{aligned}
(4-50) \quad &\left( \frac{\partial}{\partial y_h} J_\varepsilon(\mathcal{W}_{\varepsilon, \xi}) \right)_{|y=0} \\
&= -\varepsilon d_1 \left( \frac{\partial}{\partial y_k} H(\xi(y)) \right)_{|y=0} + \varepsilon d_2 \left( \frac{\partial}{\partial y_k} \pi_{ij}(\xi(y)) \right)_{|y=0} + o(\varepsilon),
\end{aligned}$$

where

$$d_1 := \kappa_s \int_{\mathbb{R}_+^{n+1}} x_N^{2-2s} x_k \nabla W \nabla \partial_h W dx dx_N$$

and

$$d_2 := 2\kappa_s \int_{\mathbb{R}_+^{n+1}} x_N^{2-2s} x_k \partial_i W \partial_{j_e}^2 W dx dx_N.$$

• For  $\frac{1}{2} \leq s < 1$ , using again [Lemma 4.7](#), we get

$$\begin{aligned}
(4-51) \quad \mathcal{J}_1 &= \kappa_s \int_{B_{2r_0/\varepsilon}^+} x_N^{1-2s} |\bar{g}_{\xi(y)}(\varepsilon x, \varepsilon x_N)|^{\frac{1}{2}} \\
&\quad \left\{ \bar{g}_{\xi(y)}^{ij}(\varepsilon x, \varepsilon x_N) \partial_i \mathcal{W}_{\varepsilon, \xi(y)} \partial_j \frac{\partial \mathcal{W}_{\varepsilon, \xi(y)}}{\partial y_h} \right. \\
&\quad \left. + \partial_N \mathcal{W}_{\varepsilon, \xi(y)} \partial_N \frac{\partial \mathcal{W}_{\varepsilon, \xi(y)}}{\partial y_h} \right\} dx dx_N
\end{aligned}$$



$$\begin{aligned}
&= -\frac{\varepsilon^2}{12} R_{kl,m} \kappa_s \sum_{e=1}^n \frac{\partial \mathcal{K}_e}{\partial y_h}(y, \xi(y)) \int_{\mathbb{R}_+^{n+1}} x_N^{1-2s} x_k x_l x_m \nabla W \nabla \partial_e W \, dx \, dx_N \\
&\quad + \frac{\varepsilon^2}{6} R_{ijkl,m} \kappa_s \sum_{e=1}^n \frac{\partial \mathcal{K}_e}{\partial y_h}(y, \xi(y)) \\
&\quad \quad \cdot \int_{\mathbb{R}_+^{n+1}} x_N^{1-2s} x_k x_l x_m \partial_i W \partial_{j_e}^2 W(x, x_N) \, dx \, dx_N \\
&\quad - \frac{\varepsilon^2}{2} (-R_{NN,k} + \pi_{is,k} \pi_{si}) \kappa_s \sum_{e=1}^n \frac{\partial \mathcal{K}_e}{\partial y_h}(y, \xi(y)) \\
&\quad \quad \cdot \int_{\mathbb{R}_+^{n+1}} x_N^{3-2s} x_k \nabla W \nabla \partial_e W \, dx \, dx_N \\
&\quad + (R_{iNjN,k} + 7\pi_{jh,k} \pi_{hi}) \kappa_s \sum_{e=1}^n \frac{\partial \mathcal{K}_e}{\partial y_h}(y, \xi(y)) \\
&\quad \quad \cdot \int_{\mathbb{R}_+^{n+1}} x_N^{3-2s} x_k \partial_i W \partial_{j_e}^2 W \, dx \, dx_N \\
&\quad + o(\varepsilon^2).
\end{aligned}$$

The second term  $\mathcal{J}_2$  can be estimated as

$$\begin{aligned}
(4-52) \quad \mathcal{J}_2 &= \varepsilon^{1+2s} \kappa_s \int_{B_{2r_0/\varepsilon}^+} E(\varepsilon x_N) \mathcal{W}_{\varepsilon, \xi(y)} \frac{\partial}{\partial y_h} \mathcal{W}_{\varepsilon, \xi(y)} |\bar{g}_{\xi(y)}(\varepsilon x, \varepsilon x_N)|^{\frac{1}{2}} \, dx \, dx_N \\
&= \varepsilon^{1+2s} \kappa_s \int_{B_{2r_0/\varepsilon}^+} E(\varepsilon x_N) W \chi(\varepsilon x, \varepsilon x_N) \\
&\quad \cdot \left( \frac{1}{\varepsilon} \chi_r(\varepsilon x, \varepsilon x_N) \sum_{e=1}^n \left[ \partial_e W(x, x_N) \frac{\partial \mathcal{K}_e}{\partial y_h}(y, \xi^{-1}(\exp_{\xi(y)})(\varepsilon x)) \right] \right. \\
&\quad \quad \left. + \mathcal{O} \left( \varepsilon^{n-2s} \frac{|\nabla \chi_r|(|(x-y, x_N)|)}{|(x-y, x_N)|^{N-2s}} \right) \right) |\bar{g}_{\xi(y)}(\varepsilon x, \varepsilon x_N)|^{\frac{1}{2}} \, dx \, dx_N \\
&= o(\varepsilon^2).
\end{aligned}$$

Similarly,

$$\begin{aligned}
(4-53) \quad \mathcal{J}_3 &= \int_{B_{2r_0/\varepsilon}} \mathcal{W}_{\varepsilon, \xi(y)} \frac{\partial}{\partial y_h} \mathcal{W}_{\varepsilon, \xi(y)} |g_{\xi(y)}(\varepsilon x, \varepsilon x_N)|^{\frac{1}{2}} \, dx \\
&= \int_{B_{2r_0/\varepsilon}} \omega \chi_{r/\varepsilon} \left( \frac{1}{\varepsilon} \chi_{r/\varepsilon} \sum_{e=1}^n \left[ \partial_e \omega \frac{\partial \mathcal{K}_e}{\partial y_h}(y, \xi^{-1}(\exp_{\xi(y)})(\varepsilon x)) \right] \right. \\
&\quad \quad \left. + \mathcal{O} \left( \varepsilon^{n-2s} \frac{|\nabla \chi_r|(|(x-y)|)}{|(x-y)|^{N-2s}} \right) \right) |g_{\xi(y)}(\varepsilon x)|^{\frac{1}{2}} \, dx \\
&= -\frac{\varepsilon^2}{12} R_{kl,m} \sum_{e=1}^n \frac{\partial \mathcal{K}_e}{\partial y_h}(y, \xi(y)) \int_{\mathbb{R}^n} x_k x_l x_m \omega \partial_e \omega \, dx + o(\varepsilon^2)
\end{aligned}$$

and

$$\begin{aligned}
(4-54) \quad \mathcal{J}_4 &= \int_{B_{2r_0/\varepsilon}} f(\mathcal{W}_{\varepsilon, \xi(y)}) \frac{\partial}{\partial y_h} \mathcal{W}_{\varepsilon, \xi(y)} |g_{\xi(y)}(\varepsilon x)|^{\frac{1}{2}} dx \\
&= \int_{B_{2r_0/\varepsilon}} f(\omega \chi_{r/\varepsilon}) \left( \frac{1}{\varepsilon} \chi_{r/\varepsilon} \sum_{e=1}^n \left[ \partial_e \omega \frac{\partial \mathcal{K}_e}{\partial y_h} (y, \xi^{-1}(\exp_{\xi(y)})(\varepsilon x)) \right] \right. \\
&\quad \left. + \mathcal{O} \left( \varepsilon^{n-2s} \frac{|\nabla \chi_r|(|(x-y)|)}{|(x-y)|^{N-2s}} \right) \right) |g_{\xi(y)}(\varepsilon x)|^{\frac{1}{2}} dx \\
&= -\frac{\varepsilon^2}{12} R_{kl,m} \sum_{e=1}^n \frac{\partial \mathcal{K}_e}{\partial y_h} (y, \xi(y)) \int_{\mathbb{R}^n} x_k x_l x_m f(\omega) \partial_e \omega dx + o(\varepsilon^2).
\end{aligned}$$

Arguing as in the first case and using (4-51)–(4-54), we deduce that

$$\begin{aligned}
&\frac{\partial}{\partial y_h} J_{\varepsilon}(\mathcal{W}_{\varepsilon, \xi}) \\
&= -\frac{\varepsilon^2}{12} R_{kl,m} \sum_{e=1}^n \frac{\partial \mathcal{K}_e}{\partial y_h} (y, \xi(y)) \\
&\quad \cdot \left[ \kappa_s \int_{\mathbb{R}_+^{n+1}} x_N^{1-2s} x_k x_l x_m \nabla W \nabla \partial_e W dx dx_N + \int_{\mathbb{R}^n} x_k x_l x_m (\omega - f(\omega)) \partial_e \omega dx \right] \\
&\quad + \frac{\varepsilon^2}{6} R_{ikjl,m} \kappa_s \sum_{e=1}^n \frac{\partial \mathcal{K}_e}{\partial y_h} (y, \xi(y)) \int_{\mathbb{R}_+^{n+1}} x_N^{1-2s} x_k x_l x_m \partial_i W \partial_{j_e}^2 W(x, x_N) dx dx_N \\
&\quad - \frac{\varepsilon^2}{2} (-R_{NN,k} + \pi_{is,k} \pi_{si}) \kappa_s \sum_{e=1}^n \frac{\partial \mathcal{K}_e}{\partial y_h} (y, \xi(y)) \int_{\mathbb{R}_+^{n+1}} x_N^{3-2s} x_k \nabla W \nabla \partial_e W dx dx_N \\
&\quad + (R_{iNjN,k} + 7\pi_{jh,k} \pi_{hi}) \kappa_s \sum_{e=1}^n \frac{\partial \mathcal{K}_e}{\partial y_h} (y, \xi(y)) \int_{\mathbb{R}_+^{n+1}} x_N^{3-2s} x_k \partial_i W \partial_{j_e}^2 W dx dx_N \\
&\quad + o(\varepsilon^2).
\end{aligned}$$

Therefore

$$\begin{aligned}
&\left( \frac{\partial}{\partial y_h} J_{\varepsilon}(\mathcal{W}_{\varepsilon, \xi}) \right)_{|y=0} \\
&= \frac{\varepsilon^2}{12} b_1 \left( \frac{\partial}{\partial y_m} R_{kl}(\xi(y)) \right)_{|y=0} - \frac{\varepsilon^2}{6} b_2 \left( \frac{\partial}{\partial y_m} R_{ikjl}(\xi(y)) \right)_{|y=0} \\
&\quad - \frac{\varepsilon^2}{2} b_3 \left( - \left( \frac{\partial}{\partial y_k} R_{NN}(\xi(y)) \right) + \left( \frac{\partial}{\partial y_k} \pi_{is}(\xi(y)) \right) \pi_{si}(\xi(y)) \right)_{|y=0} \\
&\quad + \varepsilon^2 b_4 \left( \left( \frac{\partial}{\partial y_k} R_{iNjN}(\xi(y)) \right) + 7 \left( \frac{\partial}{\partial y_k} \pi_{jh}(\xi(y)) \right) \pi_{hi}(\xi(y)) \right)_{|y=0} \\
&\quad + o(\varepsilon^2),
\end{aligned}$$

where we have set

$$\begin{aligned}
b_1 &:= \kappa_s \int_{\mathbb{R}_+^{n+1}} x_N^{1-2s} x_k x_l x_m \nabla W \nabla \partial_h W \, dx \, dx_N + \int_{\mathbb{R}^n} x_k x_l x_m (\omega - f(\omega)) \partial_h \omega \, dx, \\
b_2 &:= \kappa_s \int_{\mathbb{R}_+^{n+1}} x_N^{1-2s} x_k x_l x_m \partial_i W \partial_{jh}^2 W \, dx \, dx_N, \\
b_3 &:= \kappa_s \int_{\mathbb{R}_+^{n+1}} x_N^{3-2s} x_k \nabla W \nabla \partial_e W \, dx \, dx_N, \\
b_4 &:= \kappa_s \int_{\mathbb{R}_+^{n+1}} x_N^{3-2s} x_k \partial_i W \partial_{je}^2 W \, dx \, dx_N.
\end{aligned}$$

This prove the desired result.  $\square$

### Appendix: Proof of Lemma 2.7

The proof of Lemma 2.7 is based on the following preliminary results.

**Lemma A.1.** *Let  $0 < s < 1$ ,  $a \in \mathbb{R}$  and  $0 < R_1 < R_2$ . We denote*

$$A_{\varepsilon^{-1}}^+ = B_{R_2 \varepsilon^{-1}}^+ \setminus B_{R_1 \varepsilon^{-1}}^+.$$

Then, as  $\varepsilon \rightarrow 0$ , we have the

$$(A-1) \quad \int_{A_{\varepsilon^{-1}}^+} \frac{x_N^{1-2s}}{|(x, x_N)|^{n-2s+2+a}} \, dx \, dx_N = \begin{cases} \mathcal{O}(\varepsilon^a) & \text{for } a \neq 0, \\ \mathcal{O}(|\log \varepsilon|) & \text{for } a = 0, \end{cases}$$

$$(A-2) \quad \int_{A_{\varepsilon^{-1}}^+} \frac{x_N^{2s-1}}{|(x, x_N)|^{n+2s+a}} \, dx \, dx_N = \begin{cases} \mathcal{O}(\varepsilon^a) & \text{for } a \neq 0, \\ \mathcal{O}(|\log \varepsilon|) & \text{for } a = 0. \end{cases}$$

*Proof.* To prove the first inequality, we decompose the domain of integration

$$A_{\varepsilon^{-1}}^+ = (A_{\varepsilon^{-1}}^+ \cup \{|x_N| \geq |x|\}) \cup (A_{\varepsilon^{-1}}^+ \cup \{|x_N| \leq |x|\})$$

and estimate each part separately. If  $|x_N| \geq |x|$ , then it holds that

$$|x_N| \leq |(x, x_N)| \leq \sqrt{2}|x_N|.$$

Hence we get

$$\begin{aligned}
(A-3) \quad & \int_{A_{\varepsilon^{-1}}^+ \cup \{|x_N| \geq |x|\}} \frac{x_N^{1-2s}}{|(x, x_N)|^{n-2s+2+a}} \, dx \, dx_N \\
& \leq \max\{1, \sqrt{2}^{2s-1}\} \int_{A_{\varepsilon^{-1}}^+ \cup \{|x_N| \geq |x|\}} \frac{1}{|(x, x_N)|^{n+a+1}} \, dx \, dx_N \\
& \leq C \int_{A_{\varepsilon^{-1}}^+} \frac{1}{|(x, x_N)|^{n+a+1}} \, dx \, dx_N = \begin{cases} \mathcal{O}(\varepsilon^a) & \text{for } a \neq 0, \\ \mathcal{O}(|\log \varepsilon|) & \text{for } a = 0. \end{cases}
\end{aligned}$$

Now, if  $|x_N| \leq |x|$ , we have that

$$\frac{1}{\sqrt{2\varepsilon}} \leq \frac{1}{\sqrt{2}} |(x, x_N)| \leq |x| \leq |(x, x_N)| \leq \frac{2}{\varepsilon}$$

for  $(x, x_N) \in A_{\varepsilon^{-1}}^+$ . Therefore,

$$\begin{aligned} \text{(A-4)} \quad & \int_{A_{\varepsilon^{-1}}^+ \cup \{|x_N| \leq |x|\}} \frac{x_N^{1-2s}}{|(x, x_N)|^{n-2s+2+a}} dx dx_N \\ & \leq \int_{\{\frac{1}{\sqrt{2\varepsilon}} \leq |x| \leq \frac{2}{\varepsilon}\}} \int_{\{|x_N| \leq |x|\}} \frac{x_N^{1-2s}}{|x|^{n-2s+2+a}} dx dx_N \\ & = \frac{1}{1-s} \int_{\{\frac{1}{\sqrt{2\varepsilon}} \leq |x| \leq \frac{2}{\varepsilon}\}} \frac{|x|^{2-2s}}{|x|^{n-2s+2+a}} dx \\ & = \frac{1}{1-s} \int_{\{\frac{1}{\sqrt{2\varepsilon}} \leq |x| \leq \frac{2}{\varepsilon}\}} \frac{1}{|x|^{n+a}} dx = \begin{cases} \mathcal{O}(\varepsilon^a) & \text{for } a \neq 0, \\ \mathcal{O}(|\log \varepsilon|) & \text{for } a = 0. \end{cases} \end{aligned}$$

Combining the above two estimates, we achieve the proof of the lemma.  $\square$

The second preliminary result is:

**Lemma A.2.** *Assume that  $|(x, x_N)| \geq R_0$  for some fixed  $R_0 > 0$  sufficiently large. Then:*

- (i)  $|W(x, x_N)| \leq \frac{C}{|(x, x_N)|^{n-2s}}$ .
- (ii)  $|\nabla_x W(x, x_N)| \leq \frac{C}{|(x, x_N)|^{n-2s+1}}$  and  $|\partial_{x_N} W(x, x_N)| \leq \left( \frac{C}{|(x, x_N)|^{n-2s+1}} + \frac{Cx_N^{2s-1}}{|(x, x_N)|^{n+2s}} \right)$ .
- (iii) For  $i = 1, \dots, n$

$$|\nabla \partial_i W(x, x_N)| \leq \left( \frac{C}{|(x, x_N)|^{n-2s+2}} + \frac{Cx_N^{2s-1}}{|(x, x_N)|^{n+2s+1}} \right)$$

for some positive constant  $C = C(s, n, R_0)$ .

*Proof.* Using Green's representation formula for (2-5) we have that

$$\text{(A-5)} \quad W(x, x_N) = a_{n,s} \int_{\mathbb{R}^n} \frac{\omega^p - \omega}{|(x-y, x_N)|^{n-2s}} dy,$$

where  $1 < p < \frac{n+2s}{n-2s}$  and  $a_{n,s}$  is a positive constant depending only on  $n$  and  $s$  (see [13; 14]).

To estimate  $W(x, x_N)$  we discuss two cases. In the range  $|x| \leq |x_N|$ , we have  $|(x, x_N)| \leq \sqrt{2}|x_N|$ . Then, by using the fact that the function  $\omega = W(x, 0)$  satisfies (2-1), we obtain

$$\begin{aligned}
 \text{(A-6)} \quad |W(x, x_N)| &= a_{n,s} \left| \int_{\mathbb{R}^n} \frac{\omega^p}{|(x-y, x_N)|^{n-2s}} - \frac{\omega}{|(x-y, x_N)|^{n-2s}} dy \right| \\
 &\leq C \int_{\mathbb{R}^n} \left( \frac{1}{1+|y|^{n+2s}} \right) \frac{1}{|(x-y, x_N)|^{n-2s}} dy \\
 &\leq C \int_{\mathbb{R}^n} \frac{1}{1+|y|^{n+2s}} \frac{1}{|x_N|^{n-2s}} dy \leq \frac{C}{|x_N|^{n-2s}} \leq \frac{C}{|(x, x_N)|^{n-2s}}
 \end{aligned}$$

for  $|(x, x_N)| \geq R_0$  large and  $|x_N| \geq |x|$  where here and below  $C$  is a positive constant, depending only on  $n$  and  $s$ , which is allowed to vary from one formula to another. Now, in the range  $|x| \geq |x_N|$  we have that  $|(x, x_N)| \leq \sqrt{2}|x|$ . Then arguing as before we get

$$\begin{aligned}
 \text{(A-7)} \quad |W(x, x_N)| &\leq C \int_{\mathbb{R}^n} \left( \frac{1}{1+|y|^{n+2s}} \right) \frac{1}{|(x-y, x_N)|^{n-2s}} dy \\
 &\leq C \int_{\mathbb{R}^n} \frac{1}{1+|y|^{n+2s}} \frac{1}{|x-y|^{n-2s}} dy \\
 &= C \left\{ \int_{|y-x| > \frac{1}{2}|x|} \frac{1}{1+|y|^{n+2s}} \frac{1}{|x-y|^{n-2s}} dy \right. \\
 &\quad \left. + \int_{|y-x| < \frac{1}{2}|x|} \frac{1}{1+|y|^{n+2s}} \frac{1}{|x-y|^{n-2s}} dy \right\} \\
 &\leq \frac{C}{|x|^{n-2s}} + \frac{C}{|x|^n} \leq \frac{C}{|(x, x_N)|^{n-2s}}
 \end{aligned}$$

for  $|(x, x_N)| \geq R_0$  large and  $|x| \geq |x_N|$ . Combining the above two estimates, we get the first estimate (i).

To estimate  $|\nabla W|$  we can argue similarly. First, for  $|x| \leq |x_N|$ , we have  $|(x, x_N)| \leq \sqrt{2}|x_N|$  and from (2-1), one deduces that

$$\begin{aligned}
 \text{(A-8)} \quad |\nabla_{(x, x_N)} W(x, x_N)| &\leq \left| a_{n,s} \int_{\mathbb{R}^n} \nabla_{(x, x_N)} \frac{\omega^p - \omega}{|(x-y, x_N)|^{n-2s}} dy \right| \\
 &\leq C \int_{\mathbb{R}^n} \frac{1}{1+|y|^{n+2s}} \left| \nabla_{(x, x_N)} \frac{1}{|(x-y, x_N)|^{n-2s}} \right| dy \\
 &\leq C \int_{\mathbb{R}^n} \frac{1}{1+|y|^{n+2s}} \frac{1}{|(x-y, x_N)|^{n-2s+1}} dy \\
 &\leq C \int_{\mathbb{R}^n} \frac{1}{1+|y|^{n+2s}} \frac{1}{|x_N|^{n-2s+1}} dy \\
 &= \frac{C}{|x_N|^{n-2s+1}} \leq \frac{C}{|(x, x_N)|^{n-2s+1}}.
 \end{aligned}$$

Now, for  $|x| \geq |x_N|$ , we have that  $|(x, x_N)| \leq \sqrt{2}|x|$ . Then, integrating by parts one gets

$$\begin{aligned} \nabla_x W(x, x_N) &= -a_{n,s} \int_{\mathbb{R}^n} (\omega^p - \omega) \nabla_y \left( \frac{1}{|(x-y, x_N)|^{n-2s}} \right) dy \\ &= - \int_{|y-x| \geq \frac{1}{2}|x|} (\omega^p - \omega) \nabla_y \left( \frac{1}{|(x-y, x_N)|^{n-2s}} \right) dy \\ &\quad + \int_{|y-x| \leq \frac{1}{2}|x|} \nabla_y (\omega^p - \omega) \left( \frac{dy}{|(x-y, x_N)|^{n-2s}} \right) \\ &\quad - \int_{|y-x| = \frac{1}{2}|x|} (\omega^p - \omega) \left( \frac{\sigma_y dS_y}{|(x-y, x_N)|^{n-2s}} \right), \end{aligned}$$

where  $\sigma_y$  and  $dS_y$  are respectively the outward unit normal vector and the surface measure on the sphere  $|y-x| = \frac{1}{2}|x|$  respectively. Notice that if  $|y-x| \leq \frac{1}{2}|x|$  then  $|y| \geq \frac{1}{2}|x|$  and we derive from the above that

$$\begin{aligned} \text{(A-9)} \quad |\nabla_x W(x, x_N)| &\leq \frac{C}{|x|^{n-2s+1}} \int_{|y-x| \geq \frac{1}{2}|x|} \frac{dy}{1+|y|^{n+2s}} \\ &\quad + \frac{C}{|x|^{n+2s+1}} \int_{|y-x| \leq \frac{1}{2}|x|} \frac{dy}{|(x-y, x_N)|^{n-2s}} + \mathcal{O}\left(\frac{|x|^{n-1}}{|x|^{(n+2s)+(n-2s)}}\right) \\ &= \mathcal{O}\left(\frac{1}{|x|^{n-2s+1}}\right) + \mathcal{O}\left(\frac{1}{|x|^{n+2s+1}} \cdot |x|^{2s}\right) + \mathcal{O}\left(\frac{1}{|x|^{n+1}}\right) \\ &\leq \frac{C}{|x|^{n-2s+1}} \\ &\leq \frac{C}{|(x, x_N)|^{n-2s+1}}. \end{aligned}$$

This together with (A-8) implies the first inequality of (ii).

Now, in the range  $|x| \geq |x_N|$  and  $|y-x| \geq \frac{1}{2}|x|$ , we have that

$$\begin{aligned} \text{(A-10)} \quad &\int_{|y-x| \geq \frac{1}{2}|x|} \frac{1}{1+|x-y|^{n+2s}} \frac{x_N}{|(y, x_N)|^{n-2s+2}} dy \\ &\leq \frac{1}{|x|^{n+2s}} \int_{\mathbb{R}^n} \frac{x_N}{|(y, x_N)|^{n-2s+2}} dy = \frac{1}{|x|^{n+2s}} \int_{\mathbb{R}^n} \frac{x_N \cdot x_N^n}{x_N^{n-2s+2} |(y, 1)|^{n-2s+2}} dy \\ &= \frac{C x_N^{2s-1}}{|x|^{n+2s}} \\ &\leq \frac{C x_N^{2s-1}}{|(x, x_N)|^{n+2s}}. \end{aligned}$$

On the other hand, for  $|x| \geq |x_N|$  and  $|y - x| \leq \frac{1}{2}|x|$ , we have that  $|y| \geq \frac{1}{2}|x|$ . Hence

$$\begin{aligned}
 \text{(A-11)} \quad & \int_{|y-x| \geq \frac{1}{2}|x|} \frac{1}{1 + |x - y|^{n+2s}} \frac{x_N}{|(y, x_N)|^{n-2s+2}} dy \\
 & \leq \frac{x_N}{|x|^{n-2s+2}} \int_{\mathbb{R}^n} \frac{1}{1 + |x - y|^{n+2s}} dy \\
 & = \frac{Cx_N}{|x|^{n-2s+2}} \leq \frac{Cx_N}{|(x, x_N)|^{n-2s+2}} \leq \frac{C}{|(x, x_N)|^{n-2s+1}}.
 \end{aligned}$$

Combining the above two estimates (A-10) and (A-11), we get that

$$\begin{aligned}
 \text{(A-12)} \quad & |\partial_{x_N} W(x, x_N)| \leq C \int_{\mathbb{R}^n} \frac{1}{1 + |x - y|^{n+2s}} \frac{x_N}{|(y, x_N)|^{n-2s+2}} dy \\
 & \leq C \left( \frac{x_N^{2s-1}}{|(x, x_N)|^{n+2s}} + \frac{1}{|(x, x_N)|^{n-2s+1}} \right).
 \end{aligned}$$

Now thanks to (A-8), (A-9) and (A-12), we get the second estimate of (i).

The last estimate (iii) for  $|\nabla \partial_i W|$  can be obtained adapting the same procedure with obvious modifications. This concludes the proof of Lemma A.2.  $\square$

## References

- [1] C. O. Alves and O. H. Miyagaki, “Existence and concentration of solution for a class of fractional elliptic equation in  $\mathbb{R}^N$  via penalization method”, *Calc. Var. Partial Differential Equations* **55**:3 (2016), art. id. 47. MR Zbl
- [2] C. O. Alves, R. N. de Lima, and A. B. Nóbrega, “Bifurcation properties for a class of fractional Laplacian equations in  $\mathbb{R}^N$ ”, *Math. Nachr.* **291**:14-15 (2018), 2125–2144. MR
- [3] G. Autuori and P. Pucci, “Elliptic problems involving the fractional Laplacian in  $\mathbb{R}^N$ ”, *J. Differential Equations* **255**:8 (2013), 2340–2362. MR Zbl
- [4] G. M. Bisci and V. D. Rădulescu, “Ground state solutions of scalar field fractional Schrödinger equations”, *Calc. Var. Partial Differential Equations* **54**:3 (2015), 2985–3008. MR Zbl
- [5] X. Cabré and Y. Sire, “Nonlinear equations for fractional Laplacians, I: regularity, maximum principles, and Hamiltonian estimates”, *Ann. Inst. H. Poincaré C Anal. Non Linéaire* **31**:1 (2014), 23–53. MR Zbl
- [6] L. Caffarelli and L. Silvestre, “An extension problem related to the fractional Laplacian”, *Comm. Partial Differential Equations* **32**:7-9 (2007), 1245–1260. MR Zbl
- [7] M. Caponi and P. Pucci, “Existence theorems for entire solutions of stationary Kirchhoff fractional  $p$ -Laplacian equations”, *Ann. Mat. Pura Appl.* (4) **195**:6 (2016), 2099–2129. MR Zbl
- [8] S.-Y. A. Chang and M. d. M. González, “Fractional Laplacian in conformal geometry”, *Adv. Math.* **226**:2 (2011), 1410–1432. MR Zbl
- [9] G. Chen, “Multiple semiclassical standing waves for fractional nonlinear Schrödinger equations”, *Nonlinearity* **28**:4 (2015), 927–949. MR Zbl
- [10] G. Chen and Y. Zheng, “Concentration phenomenon for fractional nonlinear Schrödinger equations”, *Commun. Pure Appl. Anal.* **13**:6 (2014), 2359–2376. MR Zbl

- [11] W. Chen, S. Deng, and S. Kim, “Clustered solutions to low-order perturbations of fractional Yamabe equations”, *Calc. Var. Partial Differential Equations* **56**:6 (2017), art. id. 160. [MR](#) [Zbl](#)
- [12] M. Cheng, “Bound state for the fractional Schrödinger equation with unbounded potential”, *J. Math. Phys.* **53**:4 (2012), art. id. 043507. [MR](#) [Zbl](#)
- [13] W. Choi and S. Kim, “On perturbations of the fractional Yamabe problem”, *Calc. Var. Partial Differential Equations* **56**:1 (2017), art. id. 14. [MR](#) [Zbl](#)
- [14] W. Choi, S. Kim, and K.-A. Lee, “Asymptotic behavior of solutions for nonlinear elliptic problems with the fractional Laplacian”, *J. Funct. Anal.* **266**:11 (2014), 6531–6598. [MR](#) [Zbl](#)
- [15] J. Dávila, M. del Pino, and Y. Sire, “Nondegeneracy of the bubble in the critical case for nonlocal equations”, *Proc. Amer. Math. Soc.* **141**:11 (2013), 3865–3870. [MR](#) [Zbl](#)
- [16] J. Dávila, M. del Pino, and J. Wei, “Concentrating standing waves for the fractional nonlinear Schrödinger equation”, *J. Differential Equations* **256**:2 (2014), 858–892. [MR](#) [Zbl](#)
- [17] J. Dávila, M. del Pino, S. Dipierro, and E. Valdinoci, “Concentration phenomena for the nonlocal Schrödinger equation with Dirichlet datum”, *Anal. PDE* **8**:5 (2015), 1165–1235. [MR](#) [Zbl](#)
- [18] E. Di Nezza, G. Palatucci, and E. Valdinoci, “Hitchhiker’s guide to the fractional Sobolev spaces”, *Bull. Sci. Math.* **136**:5 (2012), 521–573. [MR](#) [Zbl](#)
- [19] S. Dipierro, G. Palatucci, and E. Valdinoci, “Existence and symmetry results for a Schrödinger type problem involving the fractional Laplacian”, *Matematiche* **68**:1 (2013), 201–216. [MR](#) [Zbl](#)
- [20] J. F. Escobar, “Conformal deformation of a Riemannian metric to a scalar flat metric with constant mean curvature on the boundary”, *Ann. of Math. (2)* **136**:1 (1992), 1–50. [MR](#) [Zbl](#)
- [21] M. M. Fall, F. Mahmoudi, and E. Valdinoci, “Ground states and concentration phenomena for the fractional Schrödinger equation”, *Nonlinearity* **28**:6 (2015), 1937–1961. [MR](#) [Zbl](#)
- [22] P. Felmer, A. Quaas, and J. Tan, “Positive solutions of the nonlinear Schrödinger equation with the fractional Laplacian”, *Proc. Roy. Soc. Edinburgh Sect. A* **142**:6 (2012), 1237–1262. [MR](#) [Zbl](#)
- [23] A. Fiscella, P. Pucci, and S. Saldi, “Existence of entire solutions for Schrödinger–Hardy systems involving two fractional operators”, *Nonlinear Anal.* **158** (2017), 109–131. [MR](#) [Zbl](#)
- [24] R. L. Frank and E. Lenzmann, “Uniqueness of non-linear ground states for fractional Laplacians in  $\mathbb{R}^n$ ”, *Acta Math.* **210**:2 (2013), 261–318. [MR](#) [Zbl](#)
- [25] R. L. Frank, E. Lenzmann, and L. Silvestre, “Uniqueness of radial solutions for the fractional Laplacian”, *Comm. Pure and Appl. Math.* **69**:9 (2016), 1671–1726. [Zbl](#)
- [26] M. d. M. González and J. Qing, “Fractional conformal Laplacians and fractional Yamabe problems”, *Anal. PDE* **6**:7 (2013), 1535–1576. [MR](#) [Zbl](#)
- [27] C. R. Graham and M. Zworski, “Scattering matrix in conformal geometry”, *Invent. Math.* **152**:1 (2003), 89–118. [MR](#) [Zbl](#)
- [28] S. Kim, M. Musso, and J. Wei, “Existence theorems of the fractional Yamabe problem”, *Anal. PDE* **11**:1 (2018), 75–113. [MR](#) [Zbl](#)
- [29] N. S. Landkof, *Foundations of modern potential theory*, Grundle. Math. Wissen. **180**, Springer, Heidelberg, 1972. [MR](#)
- [30] C.-S. Lin, W.-M. Ni, and I. Takagi, “Large amplitude stationary solutions to a chemotaxis system”, *J. Differential Equations* **72**:1 (1988), 1–27. [MR](#) [Zbl](#)
- [31] R. R. Mazzeo and R. B. Melrose, “Meromorphic extension of the resolvent on complete spaces with asymptotically constant negative curvature”, *J. Funct. Anal.* **75**:2 (1987), 260–310. [MR](#) [Zbl](#)



- [32] A. M. Micheletti and A. Pistoia, “The role of the scalar curvature in a nonlinear elliptic problem on Riemannian manifolds”, *Calc. Var. Partial Differential Equations* **34**:2 (2009), 233–265. [MR](#) [Zbl](#)
- [33] W.-M. Ni and I. Takagi, “On the shape of least-energy solutions to a semilinear Neumann problem”, *Comm. Pure Appl. Math.* **44**:7 (1991), 819–851. [MR](#) [Zbl](#)
- [34] W.-M. Ni and I. Takagi, “Locating the peaks of least-energy solutions to a semilinear Neumann problem”, *Duke Math. J.* **70**:2 (1993), 247–281. [MR](#) [Zbl](#)
- [35] S. Secchi, “Ground state solutions for nonlinear fractional Schrödinger equations in  $\mathbb{R}^N$ ”, *J. Math. Phys.* **54**:3 (2013), art. id. 031501. [MR](#) [Zbl](#)
- [36] R. Servadei and E. Valdinoci, “Mountain pass solutions for non-local elliptic operators”, *J. Math. Anal. Appl.* **389**:2 (2012), 887–898. [MR](#) [Zbl](#)
- [37] R. Servadei and E. Valdinoci, “Variational methods for non-local operators of elliptic type”, *Discrete Contin. Dyn. Syst.* **33**:5 (2013), 2105–2137. [MR](#) [Zbl](#)
- [38] X. Shang and J. Zhang, “Concentrating solutions of nonlinear fractional Schrödinger equation with potentials”, *J. Differential Equations* **258**:4 (2015), 1106–1128. [MR](#) [Zbl](#)
- [39] X. Shang, J. Zhang, and Y. Yang, “On fractional Schrödinger equation in  $\mathbb{R}^N$  with critical growth”, *J. Math. Phys.* **54**:12 (2013), art. id. 121502. [MR](#) [Zbl](#)
- [40] L. E. Silvestre, *Regularity of the obstacle problem for a fractional power of the Laplace operator*, Ph.D. thesis, The University of Texas at Austin, 2005, available at <https://www.proquest.com/docview/305384256>. [MR](#)
- [41] P. R. Stinga and B. Volzone, “Fractional semilinear Neumann problems arising from a fractional Keller–Segel model”, *Calc. Var. Partial Differential Equations* **54**:1 (2015), 1009–1042. [MR](#) [Zbl](#)

Received May 13, 2021. Revised April 21, 2022.

IMENE BENDAHOU  
UNIVERSITY MUSTAPHA STAMBOULI OF MASCARA  
MASCARA  
ALGERIA  
[imene.bendahou@univ-mascara.dz](mailto:imene.bendahou@univ-mascara.dz)

ZIED KHEMIRI  
ESPRIT SCHOOL OF ENGINEERING  
TUNIS  
TUNISIA  
[zied.khemiri@esprit.tn](mailto:zied.khemiri@esprit.tn)

FETHI MAHMOUDI  
DEPARTMENT OF MATHEMATICS  
FACULTY OF SCIENCES OF TUNIS  
UNIVERSITY TUNIS EL MANAR  
TUNIS  
TUNISIA  
[fethi.mahmoudi@fst.utm.tn](mailto:fethi.mahmoudi@fst.utm.tn)



# ON SLICE ALTERNATING 3-BRAID CLOSURES

VITALIJS BREJEVS

**We construct ribbon surfaces of Euler characteristic one for several infinite families of alternating 3-braid closures. We also use a twisted Alexander polynomial obstruction to conclude the classification of smoothly slice knots which are closures of alternating 3-braids with up to 20 crossings.**

## 1. Introduction

By an *alternating braid* we mean a braid such that along any strand, over- and undercrossings alternate. Let  $\sigma_1$  and  $\sigma_2$  be the standard generators of the braid group on three strands  $B_3$ . If the closure of an alternating 3-braid has nonzero determinant, then it is isotopic to the closure of a braid

$$(\star) \quad \sigma_1^{a_1} \sigma_2^{-b_1} \sigma_1^{a_2} \sigma_2^{-b_2} \dots \sigma_1^{a_n} \sigma_2^{-b_n},$$

with  $n \geq 1$  for some  $a_i, b_i \geq 1$  for all  $i$ . Every 3-braid of the form  $(\star)$  can be equivalently described by its *associated string*  $\mathbf{a} = (2^{[a_1-1]}, b_1 + 2, \dots, 2^{[a_n-1]}, b_n + 2)$ , where  $2^{[a_i-1]}$  represents the substring consisting of the number 2 repeated  $a_i - 1$  times. Cyclic rotations and reversals of  $\mathbf{a}$  do not change the isotopy class of respective braid closures in  $S^3$ , so we consider associated strings up to those two operations. The *linear dual* of a string  $\mathbf{b} = (b_1, \dots, b_k)$  with all  $b_i \geq 2$  is defined as follows: if  $b_j \geq 3$  for some  $j$ , write  $\mathbf{b}$  in the form  $\mathbf{b} = (2^{[m_1]}, 3 + n_1, 2^{[m_2]}, 3 + n_2, \dots, 2^{[m_l]}, 2 + n_l)$  with  $m_i, n_i \geq 0$  for all  $i$ . Then its linear dual is  $\mathbf{c} = (2 + m_1, 2^{[n_1]}, 3 + m_2, 2^{[n_2]}, 3 + m_3, \dots, 3 + m_l, 2^{[n_l]})$ . If  $\mathbf{b}$  is  $(2^{[k]})$  or  $(1)$ , define its linear dual as  $(k + 1)$  or the empty string, respectively.

Given a link  $L \subset S^3$ , by a *ribbon surface* we mean a surface  $F$  bounded by  $L$  that is properly smoothly embedded in  $D^4$ , has no closed components, and may be isotoped rel boundary so that the radial distance function  $D^4 \rightarrow [0, 1]$  induces a handle decomposition on  $F$  with only 0- and 1-handles. By a *slice surface* we mean a surface  $S$  bounded by  $L$  that is properly smoothly embedded in  $D^4$  and has no closed components; neither  $F$  nor  $S$  are required to be connected or orientable. Following [5], we say that  $L$  which bounds a ribbon (or slice) surface of Euler characteristic one is  $\chi$ -*ribbon* (or  $\chi$ -*slice*); these definitions coincide with the usual

MSC2020: 57K10, 57K14.

Keywords: 3-braids, slice-ribbon conjecture, twisted Alexander polynomials.

definitions of ribbon and slice in the case of knots. Clearly, if  $L$  is  $\chi$ -ribbon, then it is also  $\chi$ -slice.

Simone [20] has classified associated strings of all alternating 3-braid closures  $L$  with nonzero determinant such that  $\Sigma_2(S^3, L)$ , the double branched cover of  $S^3$  over  $L$ , is unobstructed by Donaldson's theorem from bounding a rational ball, into five families:

$$\mathcal{S}_{2a} = \{(b_1 + 3, b_2, \dots, b_k, 2, c_l, \dots, c_1)\},$$

$$\mathcal{S}_{2b} = \{(3+x, b_1, \dots, b_{k-1}, b_k+1, 2^{[x]}, c_l+1, c_{l-1}, \dots, c_1) \mid x \geq 0 \text{ and } k+l \geq 2\},$$

$$\mathcal{S}_{2c} = \{(3+x_1, 2^{[x_2]}, 3+x_3, 2^{[x_4]}, \dots, 3+x_{2k+1}, 2^{[x_1]}, 3+x_2, 2^{[x_3]}, \\ \dots, 3+x_{2k}, 2^{[x_{2k+1}]}) \mid k \geq 0 \text{ and } x_i \geq 0 \text{ for all } i\},$$

$$\mathcal{S}_{2d} = \{(2, 2+x, 2, 3, 2^{[x-1]}, 3, 4) \mid x \geq 1\} \cup \{(2, 2, 2, 4, 4)\},$$

$$\mathcal{S}_{2e} = \{(2, b_1+1, b_2, \dots, b_k, 2, c_l, \dots, c_2, c_1+1, 2) \mid k+l \geq 3\} \cup \{(2, 2, 2, 3)\}.$$

Here strings  $(b_1, \dots, b_k)$  and  $(c_1, \dots, c_l)$  are linear duals of each other. Since  $\Sigma_2(S^3, L)$  of a  $\chi$ -slice link  $L$  bounds a rational ball [5, Proposition 2.6], every  $\chi$ -slice alternating 3-braid closure with nonzero determinant has its associated string in one of these families. Moreover, Simone has explicitly constructed rational balls for all such alternating 3-braid closures.

We show that alternating 3-braid closures whose associated strings lie in  $\mathcal{S}_{2a} \cup \mathcal{S}_{2b} \cup \mathcal{S}_{2d} \cup \mathcal{S}_{2e}$  are  $\chi$ -ribbon by exhibiting band moves, defined in Section 2, which make their link diagrams isotopic to the two- or three-component unlink. In Section 3, we consider the set  $\mathcal{S}_{2c} \setminus (\mathcal{S}_{2a} \cup \mathcal{S}_{2b} \cup \mathcal{S}_{2d} \cup \mathcal{S}_{2e})$  that includes strings associated to known non- $\chi$ -slice alternating 3-braid closures, such as certain Turk's head knots, and list more examples of potentially non- $\chi$ -slice knots and links. In Section 4 we follow [11] and [1] in applying a twisted Alexander polynomial obstruction to show that among these examples, three knots are indeed not slice; this concludes the classification of smoothly slice knots which are closures of alternating 3-braids with up to 20 crossings.

## 2. Ribbon surfaces for $\mathcal{S}_{2a} \cup \mathcal{S}_{2b} \cup \mathcal{S}_{2d} \cup \mathcal{S}_{2e}$

One may exhibit a ribbon surface for a link  $L$  as follows. By a *band move* on  $L$  we mean choosing an embedding  $\varphi : D^1 \times D^1 \hookrightarrow S^3$  of a *band* so that the image of  $\varphi$  is disjoint from  $L$  except for  $\varphi(\partial D^1 \times D^1)$  coincident with two segments of  $L$ , removing those segments, joining corresponding ends along  $\varphi(D^1 \times \partial D^1)$  and smoothing the corners. This operation amounts to removing a 1-handle in the putative ribbon surface  $F$ . If after  $n$  band moves, the resulting link is isotopic to the  $(n+1)$ -component unlink, one has indeed obtained a ribbon surface  $F$  of Euler characteristic one bounded by  $L$ , since each component of the unlink bounds a 0-handle

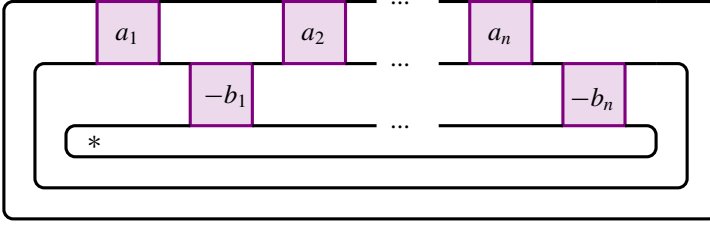

**Figure 1.** A generic alternating 3-braid closure. We denote sequences of positive (negative) crossings by blocks annotated by positive (negative) coefficients.

of  $F$ . Each band may be represented on a link diagram by an arc with endpoints on  $L$  that crosses the strands of  $L$  transversally, has no self-crossings, and is annotated by the number of half-twists in the band relative to the blackboard framing.

Given a 3-braid  $\beta = \sigma_1^{a_1} \sigma_2^{-b_1} \dots \sigma_1^{a_n} \sigma_2^{-b_n}$ , we draw it from left to right, as shown in Figure 1, and orient all strings in the closure  $\hat{\beta}$  clockwise. Choose the chessboard colouring of the diagram for  $\hat{\beta}$  where the unbounded region is white. Then there are  $m = (\sum_{i=1}^n a_i) + 1$  black regions. We can index the black regions, excluding the one not adjacent to the unbounded region (marked by  $*$  in Figure 1), by  $\{1, \dots, m-1\}$  such that the number of crossings along the boundary of the region indexed by  $i$  is given by the  $i$ -th entry of the associated string  $\mathbf{a} = (2^{\lfloor a_1 - 1 \rfloor}, b_1 + 2, \dots, 2^{\lfloor a_n - 1 \rfloor}, b_n + 2)$ , and the region indexed by  $i$  shares one crossing with each of the regions indexed by  $i-1$  and  $i+1 \pmod{m-1}$ .

**Proposition 2.1.** *Let  $\mathbf{a}$  be the associated string of an alternating 3-braid closure  $\hat{\beta}$ . If  $\mathbf{a} \in \mathcal{S}_{2a} \cup \mathcal{S}_{2d} \cup \mathcal{S}_{2e}$ , then  $\hat{\beta}$  bounds a ribbon surface with a single 1-handle. If  $\mathbf{a} \in \mathcal{S}_{2b}$ , then  $\hat{\beta}$  bounds a ribbon surface with at most two 1-handles.*

Our main observation, previously used by Lisca [14] and Lecuona [13], is that if  $\mathbf{a}$  contains two disjoint linearly dual substrings (possibly perturbed on the ends), then the link diagram of  $\hat{\beta}$  contains sub-braids which, if connected to each other by a half-twist  $(\sigma_2 \sigma_1 \sigma_2)^{-1}$ , may be cancelled out via successive isotopies. More precisely, suppose that  $(b_1, \dots, b_k)$  and  $(c_1, \dots, c_l)$  are linear duals. Let  $\mathbf{b}' = (b_1 + x_l, b_2, \dots, b_k + x_r)$  and  $\mathbf{c}' = (c_l + y_l, c_{l-1}, \dots, c_1 + y_r)$  with  $x_i, y_i \geq 0$  for  $i \in \{l, r\}$  and suppose that  $\mathbf{a} = \mathbf{b}' | \mathbf{t} | \mathbf{c}' | \mathbf{s}$ , where  $\mathbf{t}$  and  $\mathbf{s}$  are arbitrary strings, the length of  $\mathbf{t}$  is  $t \geq 0$ , and  $|$  denotes string concatenation. Consider the sub-braid  $\mathbf{B}$  in the link diagram of  $\hat{\beta}$  that exactly contains all crossings along the boundary of black regions  $2, \dots, k-1$ , all but  $x_l + 1$  leftmost crossings along the boundary of region 1, and all but  $x_r + 1$  rightmost crossings along the boundary of region  $k$ . Consider also the sub-braid  $\mathbf{C}$  that exactly contains all crossings along the boundary of regions  $k+t+2, \dots, k+t+l-1$ , all but  $y_l + 1$  leftmost crossings along the boundary of region  $k+t+1$ , and all but  $y_r + 1$  rightmost crossings along the boundary of

region  $k + t + l$ . Then  $B(\sigma_2\sigma_1\sigma_2)^{-1}C = (\sigma_2\sigma_1\sigma_2)^{-1}$ . Hence, if after applying a band move to  $\hat{\beta}$  away from  $B$  and  $C$ , they are connected by a half-twist of the three strands, one may remove all crossings in  $B$  and  $C$  via isotopies illustrated in Figure 2. We call  $B$  and  $C$  *dual sub-braids* and enclose them in all following figures in blue and chartreuse rectangles, respectively.

*Proof of Proposition 2.1.* See Figures 4–7. □

In searching for the band moves in Figures 4–7, we have used the algorithm of Owens and Swenton implemented in the KLO program [16]. The band moves we exhibit for these four families of alternating 3-braid closures are *algorithmic* in the sense of [16].

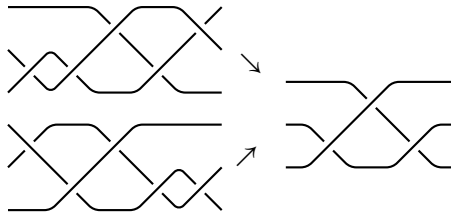

**Figure 2.** Undoing flyped tongues [22] to cancel dual sub-braids.

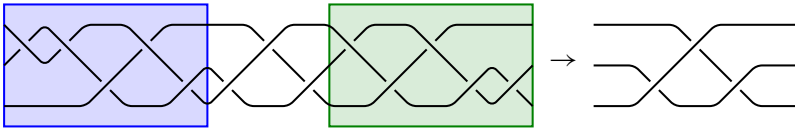

**Figure 3.** Cancellation of dual sub-braids for  $(b_1, \dots, b_k) = (2, 2, 3, 3)$  and  $(c_1, \dots, c_l) = (2, 3, 4)$  with  $x_l = x_r = y_l = y_r = 0$ . Fixing the ends on the braid shown, one may remove all crossings in  $B$  and  $C$  via moves illustrated in Figure 2.

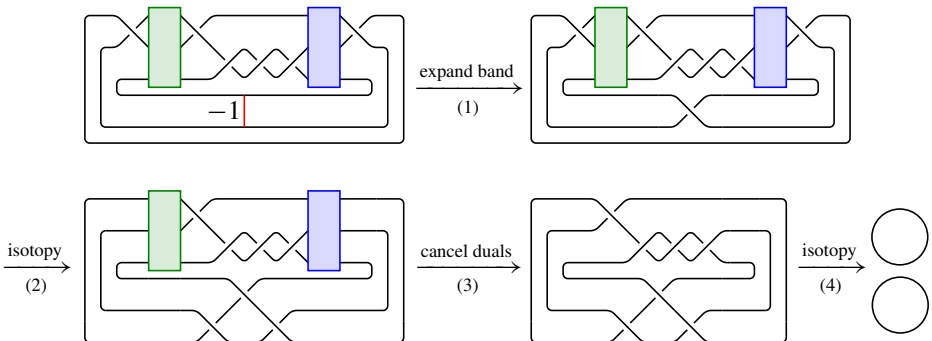

**Figure 4.** Band move for the  $S_{2a}$  case.

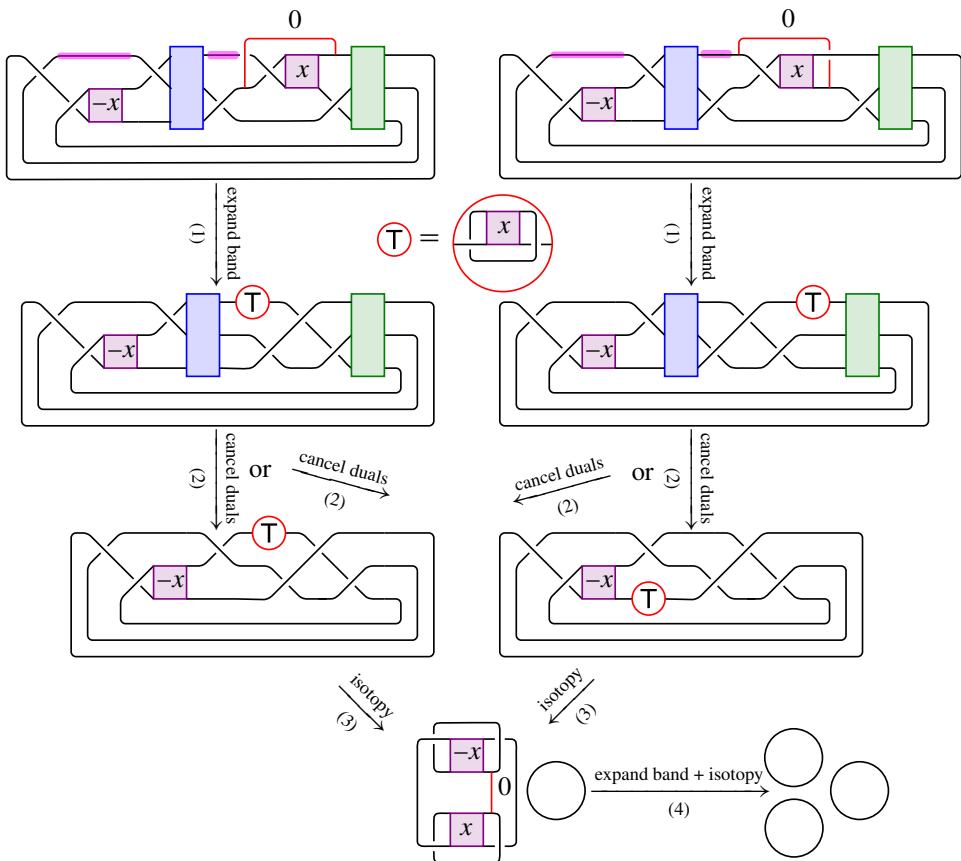
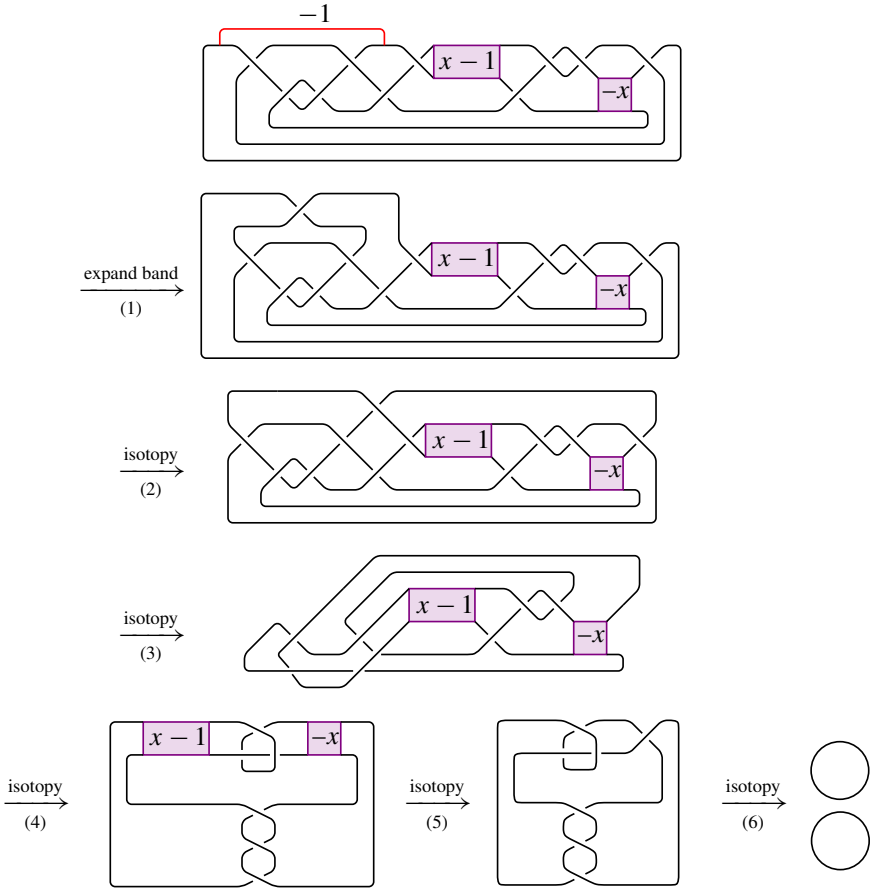

**Figure 5.** Band moves for the  $\mathcal{S}_{2b}$  case. Start with the top left diagram if the two segments highlighted in purple do not lie on the same strand, otherwise start with the top right; this ensures that after step (2), the tangle  $T$  does not lie on the otherwise unknotted split component. The nontrivial component of the link obtained after step (3) is the connected sum  $T(2, x+2) \# T(2, -(x+2))$  of two torus links.

### 3. The case of $\mathcal{S}_{2c} \setminus (\mathcal{S}_{2a} \cup \mathcal{S}_{2b} \cup \mathcal{S}_{2d} \cup \mathcal{S}_{2e})$

The remaining  $\mathcal{S}_{2c}$  family is of special interest because it contains strings associated to known examples of nonslice, nonzero determinant alternating 3-braid closures, specifically Turk’s head knots  $K_7$  [19],  $K_{11}$ ,  $K_{17}$  and  $K_{23}$  [1]; the associated string of  $K_i$  for  $i \in \{7, 11, 17, 23\}$  is  $(3^{|i|})$ . Thus, we should not expect to find a set of band moves for all links with strings in  $\mathcal{S}_{2c}$ . We also note that knots of finite concordance order belonging to Family (3) in [15] have associated strings in  $\mathcal{S}_{2c}$ .

We have that  $\mathcal{S}_{2c} \cap \mathcal{S}_{2d} = \mathcal{S}_{2c} \cap \mathcal{S}_{2e} = \emptyset$ : this can be seen by computing the  $I(\mathbf{a}) = \sum_{a \in \mathbf{a}} 3 - a$  invariant [14] which is 0 for strings in  $\mathcal{S}_{2c}$ , but 1 or 3 for strings



**Figure 6.** Band moves for the  $S_{2d}$  case with  $x \geq 1$ . In step (5), we undo  $x - 1$  crossings in both blocks by flyping the tangle on the bottom of the diagram and performing Reidemeister II moves. A similar band gives the two-component unlink for the alternating 3-braid closure with associated string  $(2, 2, 2, 4, 4)$ .

in  $S_{2d}$  or  $S_{2e}$ , respectively.<sup>1</sup> However,  $S_{2c}$  has nonzero intersection with  $S_{2a}$  and  $S_{2b}$ : if one defines a *palindrome* to be a string  $(a_1, \dots, a_n)$  such that  $a_i = a_{n-(i-1)}$  for all  $1 \leq i \leq n$ , then the following lemma holds.

**Lemma 3.1** [20, Lemma 3.6]. *Let  $\mathbf{a} = (b_1 + 3, b_2, \dots, b_k, 2, c_1, \dots, c_l) \in S_{2a}$  and  $\mathbf{b} = (3 + x, b_1, \dots, b_{k-1}, b_k + 1, 2^{\lfloor x \rfloor}, c_l + 1, c_{l-1}, \dots, c_1) \in S_{2b}$ . Then  $\mathbf{a} \in S_{2c}$  if and only if  $(b_1 + 1, b_2, \dots, b_k)$  is a palindrome and  $\mathbf{b} \in S_{2c}$  if and only if  $(b_1, \dots, b_k)$  is a palindrome.*

<sup>1</sup>Observe that if  $\mathbf{b} = (b_1, \dots, b_k)$  and  $\mathbf{c} = (c_1, \dots, c_l)$  are linearly dual to each other and  $k + l \geq 2$ , then  $I(\mathbf{b} \mid \mathbf{c}) = 2$ .



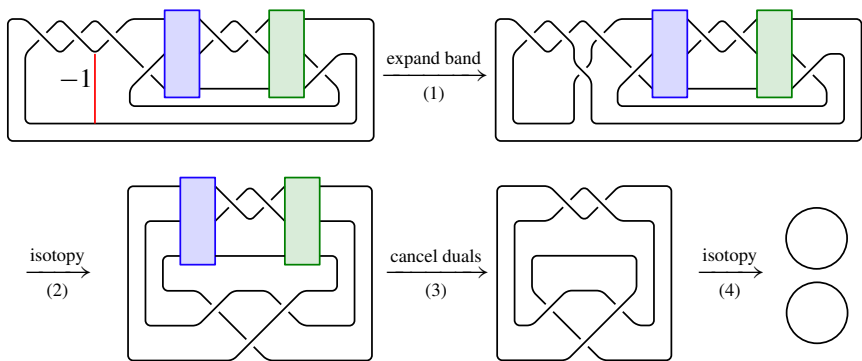

**Figure 7.** Band move for the  $S_{2e}$  case. A similar band move gives the two-component unlink for the alternating 3-braid closure with associated string  $(2, 2, 2, 3)$ .

We seek to find an easier description of the complement  $S_{2c}^\dagger := S_{2c} \setminus (S_{2a} \cup S_{2b} \cup S_{2d} \cup S_{2e})$ . Let

$$(*) \quad \mathbf{c} = (3 + x_1, 2^{[x_2]}, 3 + x_3, 2^{[x_4]}, \dots, 3 + x_{2k+1}, 2^{[x_1]}, 3 + x_2, 2^{[x_3]}, \dots, 3 + x_{2k}, 2^{[x_{2k+1}]}) \in S_{2c},$$

where  $k \geq 0$  and  $x_i \geq 0$  for all  $i$ . One can more compactly describe  $\mathbf{c}$  by its  $\mathbf{x}$ -string  $\mathbf{x}(\mathbf{c}) = [x_1, \dots, x_{2k+1}]$  (we use square brackets to denote  $\mathbf{x}$ -strings and, as with associated strings, consider them up to cyclic rotations and reversals). For example, the  $\mathbf{x}$ -string of  $(3^{[i]})$  associated with  $K_i$  is  $[0^{[i]}]$ . Also, when writing  $\mathbf{c}$  in the form  $(*)$  with the first element being at least 3, call every maximal substrings of the form  $(2^{[x]})$  or  $(3 + x)$  for  $x \geq 0$  an *entry*; the total number of entries  $e(\mathbf{c})$  in  $\mathbf{c}$  is congruent to 2 mod 4.

**Lemma 3.2.** *Let  $\mathbf{a} = (b_1 + 3, b_2, \dots, b_k, 2, c_l, \dots, c_1) \in S_{2a} \cap S_{2c}$  and  $\mathbf{b} = (3 + y, b_1, \dots, b_{k-1}, b_k + 1, 2^{[y]}, c_l + 1, c_{l-1}, \dots, c_1) \in S_{2b} \cap S_{2c}$ . Then:*

- $\mathbf{x}(\mathbf{a}) = [z_1]$  with  $z_1 \geq 1$  or  $\mathbf{x}(\mathbf{a}) = [z_1, \dots, z_{\lfloor \frac{n}{2} \rfloor}, z_{\lfloor \frac{n}{2} \rfloor + 1}, z_{\lfloor \frac{n}{2} \rfloor}, \dots, z_2, z_1 - 2]$  with  $z_1 \geq 2$  and  $n \geq 3$  odd.
- $\mathbf{x}(\mathbf{b}) = [y, 0, z_2]$  or  $\mathbf{x}(\mathbf{b}) = [y, 0, z_2, z_3, \dots, z_{\frac{n}{2}}, z_{\frac{n}{2} + 1}, z_{\frac{n}{2}}, \dots, z_3, z_2 + 1]$  with  $n \geq 4$  even.

*Proof.* Consider  $\mathbf{a}$  and define  $\mathbf{a}_c = (2, c_l, \dots, c_1)$ . Notice that  $\mathbf{a}_c$  is the linear dual of the string

$$\mathbf{a}_c^* = (b_k + 1, b_{k-1}, \dots, b_1),$$

which by Lemma 3.1 must be a palindrome, and that  $\mathbf{a} = (b_1 + 3, b_2, \dots, b_k \mid \mathbf{a}_c)$ . If  $(b_1, \dots, b_k)$  is the empty string, then  $\mathbf{a} = (2, 1) \notin S_{2c}$ . Otherwise, write

$$\mathbf{a}_c = (2^{[z_1]}, 3 + z_2, \dots, 2^{[z_n]})$$

for  $n \geq 1$  odd and  $z_1 \geq 1$ . If  $n = 1$ , then  $\mathbf{a}_c = (2^{\lfloor z_1 \rfloor})$  and  $\mathbf{a} = (3 + z_1, 2^{\lfloor z_1 \rfloor})$ , so  $\mathbf{x}(\mathbf{a}) = \lfloor z_1 \rfloor$ . If  $n > 1$ , then

$$(**) \quad \mathbf{a}_c^* = (2 + z_1, 2^{\lfloor z_2 \rfloor}, 3 + z_3, \dots, 2^{\lfloor z_{n-1} \rfloor}, 2 + z_n).$$

Thus,

$$\mathbf{a} = (3 + (z_n + 2), 2^{\lfloor z_{n-1} \rfloor}, \dots, 2^{\lfloor z_2 \rfloor}, 1 + z_1, 2^{\lfloor z_1 \rfloor}, 3 + z_2, \dots, 2^{\lfloor z_n \rfloor}).$$

If  $z_1 = 1$ , then

$$\mathbf{a} = (3 + (z_n + 2), 2^{\lfloor z_{n-1} \rfloor}, \dots, 3 + z_3, 2^{\lfloor z_1 + z_2 + 1 \rfloor}, 3 + z_2, \dots, 2^{\lfloor z_n \rfloor})$$

does not belong to  $\mathcal{S}_{2c}$  because  $e(\mathbf{a}) \equiv 0 \pmod{4}$ . If  $z_1 > 1$ , then

$$\mathbf{a} = (3 + (z_n + 2), 2^{\lfloor z_{n-1} \rfloor}, \dots, 2^{\lfloor z_2 \rfloor}, 3 + (z_1 - 2), 2^{\lfloor z_1 \rfloor}, 3 + z_2, \dots, 2^{\lfloor z_n \rfloor}).$$

Now, by considering  $(**)$  we see that  $\mathbf{a}_c^*$  is a palindrome if and only if

$$z_1 = z_n + 2, \quad z_2 = z_{n-1}, \quad \dots, \quad z_{\lfloor \frac{n}{2} \rfloor} = z_{\lfloor \frac{n}{2} \rfloor + 2},$$

so we conclude that  $\mathbf{a} \in \mathcal{S}_{2a} \cap \mathcal{S}_{2c}$  if and only if  $\mathbf{x}(\mathbf{a}) = \lfloor z_1 \rfloor$  for  $z_1 \geq 1$  or

$$\mathbf{x}(\mathbf{a}) = \lfloor z_1 \rfloor, \lfloor z_2 \rfloor, \dots, \lfloor z_{\lfloor \frac{n}{2} \rfloor} \rfloor, \lfloor z_{\lfloor \frac{n}{2} \rfloor + 1} \rfloor, \lfloor z_{\lfloor \frac{n}{2} \rfloor} \rfloor, \dots, \lfloor z_2 \rfloor, \lfloor z_1 - 2 \rfloor \quad \text{for } z_1 \geq 2 \text{ and } n \geq 3 \text{ odd.}$$

Similarly, if  $(b_1, \dots, b_k)$  is empty, then  $\mathbf{b} = (3 + y, 2^{\lfloor y \rfloor}, 2) = (3 + y, 2^{\lfloor y + 1 \rfloor}) \notin \mathcal{S}_{2c}$ . If  $k = 1$ , then the linear dual of  $(b_1)$  with  $b_1 \geq 2$  is  $(2^{\lfloor b_1 - 1 \rfloor})$ , so

$$\begin{aligned} \mathbf{b} &= (3 + y, 2^{\lfloor 0 \rfloor}, b_1 + 1, 2^{\lfloor y \rfloor}, 3 + 0, 2^{\lfloor b_1 - 2 \rfloor}) \\ &= (3 + y, 2^{\lfloor 0 \rfloor}, 3 + (b_1 - 2), 2^{\lfloor y \rfloor}, 3 + 0, 2^{\lfloor b_1 - 2 \rfloor}) \end{aligned}$$

is indeed in  $\mathcal{S}_{2c}$  and  $\mathbf{x}(\mathbf{b}) = \lfloor y \rfloor, 0, b_1 - 2$ . If  $k > 1$ , write

$$(b_1, \dots, b_k) = (2^{\lfloor z_1 \rfloor}, 3 + z_2, \dots, 2^{\lfloor z_{n-1} \rfloor}, 2 + z_n)$$

for  $n \geq 2$  even and  $z_n \geq 1$ ; its linear dual is

$$(c_1, \dots, c_l) = (2 + z_1, 2^{\lfloor z_2 \rfloor}, 3 + z_3, \dots, 2^{\lfloor z_{n-2} \rfloor}, 3 + z_{n-1}, 2^{\lfloor z_n \rfloor}).$$

When  $n = 2$ , we recover the  $k = 1$  case above, so suppose  $n > 2$ . Then we have

$$\begin{aligned} \mathbf{b} &= (3 + y, 2^{\lfloor z_1 \rfloor}, \dots, 2^{\lfloor z_{n-1} \rfloor}, 3 + z_n, 2^{\lfloor y \rfloor}, 3 + 0, 2^{\lfloor z_{n-1} \rfloor}, \\ &\quad 3 + z_{n-1}, 2^{\lfloor z_{n-2} \rfloor}, \dots, 3 + z_3, 2^{\lfloor z_2 + 1 \rfloor}). \end{aligned}$$

By comparing this with  $(*)$ , we see that  $z_1$  (which corresponds to  $x_2$ ) must be zero, and

$$(b_1, \dots, b_k) = (3 + z_2, 2^{\lfloor z_3 \rfloor}, \dots, 2^{\lfloor z_{n-1} \rfloor}, 3 + (z_n - 1)).$$

The string  $(b_1, \dots, b_k)$  is thus a palindrome precisely when

$$z_2 = z_n - 1, \quad z_3 = z_{n-1}, \quad \dots, \quad z_{\frac{n}{2}} = z_{\frac{n}{2} + 2},$$

i.e.,  $\mathbf{x}(\mathbf{b}) = \lfloor y \rfloor, 0, z_2, z_3, \dots, z_{\frac{n}{2}}, z_{\frac{n}{2} + 1}, z_{\frac{n}{2}}, \dots, z_3, z_2 + 1$ .  $\square$

In particular, we can draw the easy conclusion that if  $\mathbf{x}(\mathbf{c})$  contains neither two adjacent elements differing by 2 nor a 0, then  $\mathbf{c} \in \mathcal{S}_{2c}^\dagger$ . We now show that infinitely many  $\chi$ -ribbon links have their associated strings in  $\mathcal{S}_{2c}^\dagger$ .

**Lemma 3.3.** *Let  $\hat{\beta}$  be the closure of  $\beta = \sigma_1^{m+1}(\sigma_2^{-1}\sigma_1)^2\sigma_2^{-(m+1)}(\sigma_1\sigma_2^{-1})^2$  with the associated string  $\mathbf{c} = (3+m, 3, 3, 2^{\lfloor m \rfloor}, 3, 3)$  and  $m \geq 3$ . Then  $\mathbf{c} \in \mathcal{S}_{2c}^\dagger$  and  $\hat{\beta}$  admits a ribbon surface with a single 1-handle.*

*Proof.* We have  $\mathbf{x}(\mathbf{c}) = [m, 0, 0, 0, 0]$ , so by Lemma 3.2,  $\mathbf{c} \in \mathcal{S}_{2c}^\dagger$ . For the band move, see Figure 8.  $\square$

Using KLO, we have found that 22 out of 33 closures of alternating 3-braids with up to 20 crossings whose associated strings belong to  $\mathcal{S}_{2c}^\dagger$  are algorithmically ribbon, in each instance via at most two band moves. It is known that the Turk’s head knot  $K_7$  with the associated string in  $\mathcal{S}_{2c}^\dagger$  and 14 crossings is not slice [19]. The remaining 10 examples for which we were unable to find band moves exhibiting a  $\chi$ -ribbon surface are listed in Table 1. By a straightforward application of the Gordon–Litherland signature formula [10, Theorems 6 and 6’], the signature of the closure of a braid  $\beta = \sigma_1^{a_1}\sigma_2^{-b_1} \dots \sigma_1^{a_n}\sigma_2^{-b_n}$  with  $\sum_i a_i$  and  $\sum_i b_i$  both greater than one is

$$\sigma(\hat{\beta}) = \sum_{i=1}^n b_i - a_i.$$

Thus, for all links with associated strings in  $\mathcal{S}_{2a} \cup \mathcal{S}_{2b} \cup \mathcal{S}_{2c}$  satisfying this condition (in particular, for those in Table 1), the signature vanishes, which means that for knots, so do the Ozsváth and Szabó’s  $\tau$  and Rasmussen’s  $s$  invariants [17; 18] without giving us any sliceness obstructions; Tristram–Levine signatures for knots in Table 1 are also zero. Moreover, by comparing their hyperbolic volumes, we have verified that none of the entries in Table 1 belong to the list of “escapee”  $\chi$ -ribbon links described in [16]: this further advances them as candidates for more careful study. In Section 4 we will show that the three knots  $K_1$ ,  $K_2$  and  $K_3$  in Table 1 are not slice, which lets us conclude that every knot which is a closure of an alternating 3-braid with up to 20 crossings and whose double branched cover bounds a rational ball, except  $K_1$ ,  $K_2$ ,  $K_3$  and  $K_7$ , is slice.

**Remark 3.4.** We note that not all alternating knots can be represented as closures of alternating braids. This implies that our list of smoothly nonslice knots which are closures of alternating 3-braids with up to 20 crossings does not include, for example, the nonslice alternating knot  $5_2$ , which has braid index 3, but cannot be represented as a closure of any alternating braid [3]. A full classification of braid presentations of alternating links with braid index 3 has been given by Stoimenow in [21].

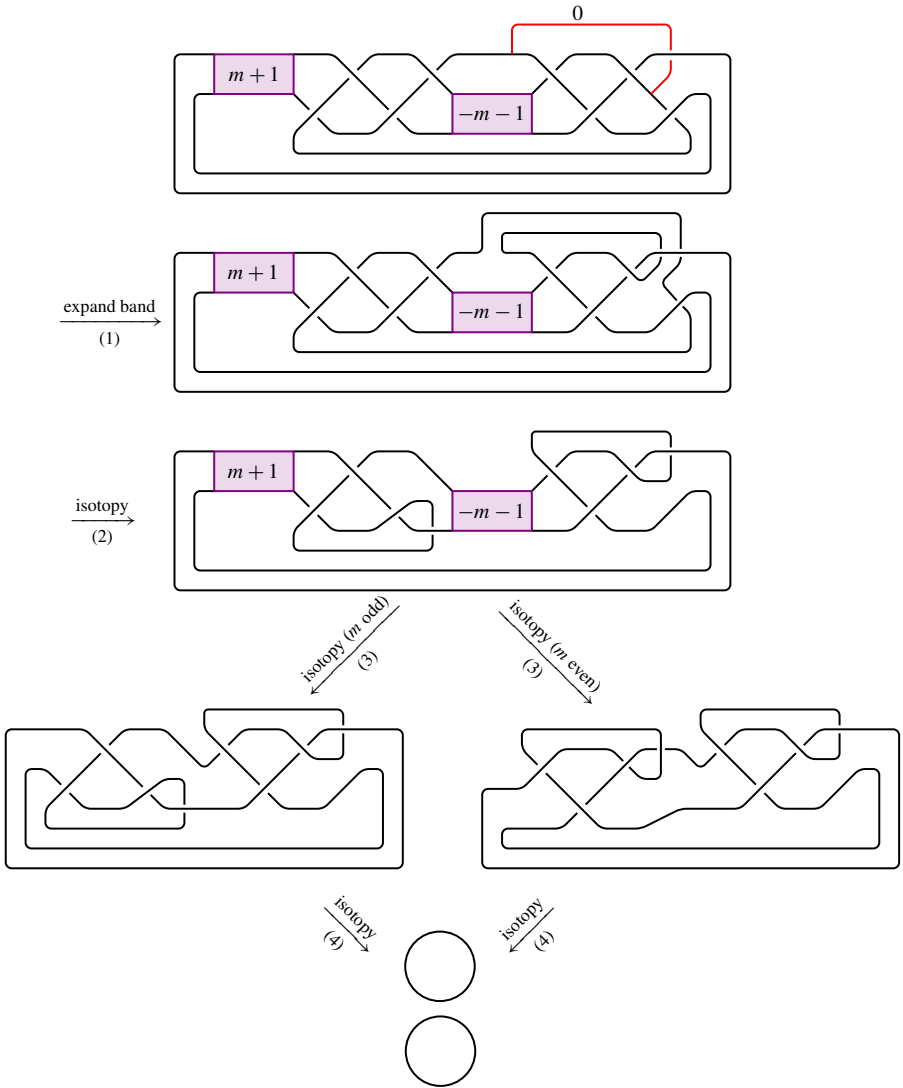

**Figure 8.** Band moves for an alternating 3-braid closure with  $x$ -string  $[m, 0, 0, 0, 0]$  for  $m \geq 3$ . In (3), we perform  $m + 1$  flypes of the tangle between two blocks with  $m$  crossings followed by Reidemeister II moves.

#### 4. Three more nonslice knots in $\mathcal{S}_{2c}^\dagger$

In this section we restrict our attention to the three knots in [Table 1](#). Let

$$\begin{aligned} \beta_1 &= \sigma_1^2 \sigma_2^{-2} \sigma_1^2 \sigma_2^{-2} \sigma_1 \sigma_2^{-2} \sigma_1^2 \sigma_2^{-2} \sigma_1^2 \sigma_2^{-1}, \\ \beta_2 &= \sigma_1^3 \sigma_2^{-2} \sigma_1 \sigma_2^{-1} \sigma_1^2 \sigma_2^{-3} \sigma_1^2 \sigma_2^{-1} \sigma_1 \sigma_2^{-2}, \\ \beta_3 &= \sigma_1^2 \sigma_2^{-1} \sigma_1 \sigma_2^{-2} \sigma_1 \sigma_2^{-1} \sigma_1 \sigma_2^{-2} \sigma_1 \sigma_2^{-1} \sigma_1^2 \sigma_2^{-1} \sigma_1 \sigma_2^{-1}, \end{aligned}$$

and let  $K_i = \hat{\beta}_i$  for  $i = 1, 2, 3$ . We will show that the knots  $K_i$  are not slice by adapting the approach of Aceto et al. [1], based in turn on work of Herald, Kirk and Livingston [11], and demonstrating that certain reduced twisted Alexander polynomials do not factor as norms; this is a generalisation of the Fox–Milnor condition on Alexander polynomials of  $K_i$  which is passed by these knots. Fix distinct primes  $p$  and  $q$ , and let  $\zeta_q$  denote a primitive  $q$ -th root of unity. The general outline of the algorithm is the following.

(1) Construct the Seifert matrix  $S_i$  for  $K_i$  coming from the standard Seifert surface  $F_i$  associated to  $K_i$  viewed as a 3-braid closure.

(2) By considering the presentation matrix  $P_i = tS_i - S_i^T \in \text{Mat}(\mathbb{Z}[t^{\pm 1}])$  of the Alexander module  $\mathcal{A}(K_i)$ , determine the structure of  $H_1(\Sigma_p(K_i))$ , the first homology of the  $p$ -fold cover of  $S^3$  branched over  $K_i$ , as well as a basis of  $H_1(\Sigma_p(K_i))$  given by lifts of curves in  $S^3 \setminus \nu(F)$ .

(3) Calculate the Blanchfield pairings  $\text{Bl}_i : \mathcal{A}(K_i) \times \mathcal{A}(K_i) \rightarrow \mathbb{Q}(t)/\mathbb{Z}[t^{\pm 1}]$  and deduce the linking pairings  $\lambda_i : H_1(\Sigma_p(K_i)) \times H_1(\Sigma_p(K_i)) \rightarrow \mathbb{Q}/\mathbb{Z}$ .

(4) Enumerate all  $\mathbb{Z}[t^{\pm 1}]$ -submodules  $N$  of  $H_1(\Sigma_p(K_i))$  with  $|N|^2 = |H_1(\Sigma_p(K_i))|$  and thus find all metabolisers of  $H_1(\Sigma_p(K_i))$ , i.e., those  $N$  on which  $\lambda_i$  vanishes.

(5) Construct nontrivial characters  $\chi : H_1(\Sigma_p(K_i)) \rightarrow \mathbb{Z}/q$  that vanish on the metabolisers.

(6) Using a Wirtinger presentation of  $\pi_1(X_i)$ , where  $X_i$  is the knot complement of  $K_i$ , construct a certain homomorphism  $\pi_1(X_i) \rightarrow \mathbb{Z} \times H_1(\Sigma_p(K_i))$  that induces a representation  $\varphi_\chi : \pi_1(X_i) \rightarrow \text{GL}(p, \mathbb{Q}(\zeta_q)[t^{\pm 1}])$  for each character in (5).

# of crossings	associated string	$\mathbf{x}$ -string	# of components
18	(3 <sup>[9]</sup> )	[0 <sup>[9]</sup> ]	3
18	(2, 4, 2, 4, 4, 2, 4, 2, 3)	[1, 1, 1, 1, 0]	1
18	(2, 2, 4, 3, 2, 5, 2, 3, 4)	[2, 1, 0, 0, 1]	1
18	(2, 3, 4, 3, 4, 3, 2, 3, 3)	[1, 0, 0, 0, 1, 0, 0]	1
20	(2, 2, 2, 3, 3, 3, 6, 3, 3, 3)	[3, 0 <sup>[6]</sup> ]	3
20	(2, 4, 2, 4, 2, 4, 2, 4, 2, 4)	[1 <sup>[5]</sup> ]	3
20	(2, 4, 2, 3, 3, 4, 2, 4, 3, 3)	[1, 1, 1, 0, 0, 0, 0]	3
20	(2, 4, 3, 2, 3, 4, 2, 3, 4, 3)	[1, 1, 0, 0, 1, 0, 0]	3
20	(2, 3, 2, 3, 2, 3, 4, 4, 4, 3)	[1, 0, 1, 0, 1, 0, 0]	3
20	(2, 2, 2, 4, 3, 2, 6, 2, 3, 4)	[3, 1, 0, 0, 1]	3

**Table 1.** Links in  $S_{2c}^\dagger$  with up to 20 crossings which are potentially non- $\chi$ -slice. In the following we show that the three knots in this table are not slice.

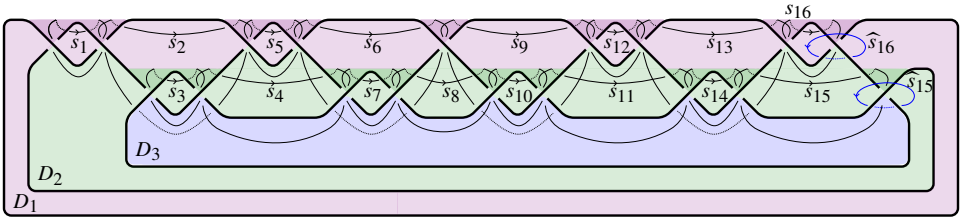

**Figure 9.** Our choice of a Seifert surface  $F_1$  for  $K_1$ . Lifts of Alexander dual curves  $\hat{s}_{15}$  and  $\hat{s}_{16}$  to generate  $H_1(\Sigma_3(K_1))$ .

(7) Use the Fox matrix for a Wirtinger presentation of  $\pi_1(X_i)$  to obtain a matrix  $\Phi_\chi$  for each  $\chi$  in (5), whose determinant  $\det \Phi_\chi$  is the reduced twisted Alexander polynomial  $\tilde{\Delta}_{K_i}^\chi(t)$ .

(8) Verify that none of the  $\tilde{\Delta}_{K_i}^\chi(t)$  factor as norms, hence providing an obstruction to sliceness of all  $K_i$ .

For reference about various terms used in this outline, we direct the reader in the first instance to [11] and [1], as well as to the survey [9]. The computations were performed in SageMath notebooks available on the author’s website.<sup>2</sup>

**4A. The Seifert matrix.** Let  $\beta$  be a 3-braid. A Seifert surface  $F$  for  $\hat{\beta}$  can be constructed by joining three discs  $D_1$ ,  $D_2$  and  $D_3$  by half-twisted bands, where each band between  $D_1$  and  $D_2$  comes from a  $\sigma_1$  term in  $\beta$ , and each band between  $D_2$  and  $D_3$  from a  $\sigma_2$  term; identify the bands with  $\sigma_i$ ’s. Let  $g$  be the genus of  $F$ . We can choose the generators of  $H_1(F)$  to be the loops running once through consecutive  $\sigma_1$ ’s and  $\sigma_2$ ’s, except for the loop between the first and last  $\sigma_1$  and the first and last  $\sigma_2$ . We order these generators  $s_1, \dots, s_{2g}$  by when the first  $\sigma_i$  through which  $s_j$  runs appears in  $\beta$ . With this setup, the Seifert matrix  $S$  can be obtained using the algorithm of Collins [2]. Such  $F$  with  $s_1, \dots, s_{2g}$  for  $K_1$  is shown in Figure 9. Also, for  $\nu(F)$  an open tubular neighbourhood of  $F$ , denote by  $\hat{s}_i$  a choice of a simple closed curve in  $S^3 \setminus \nu(F)$  that is Alexander dual to  $\{s_1, \dots, s_{2g}\}$ , i.e., which satisfies  $\text{lk}(s_i, \hat{s}_j) = \delta_{ij}$ .

**4B. Structure and bases of  $H_1(\Sigma_3(K_i))$ .** We may perform column operations on the presentation matrices  $P_i = tS_i - S_i^T$  of the Alexander modules  $\mathcal{A}(K_i)$  to transform them into the forms

$$\left( \begin{array}{c|cc} I & & 0 \\ \hline * & p_1(t) & 0 \\ & 0 & p_1(t) \end{array} \right), \quad \left( \begin{array}{c|ccc} I & & & 0 \\ \hline * & p_2(t) & 0 & 0 \\ & 0 & 1 & 0 \\ & 0 & * & p_2(t) \end{array} \right), \quad \left( \begin{array}{c|cc} I & & 0 \\ \hline * & p_3(t) & 0 \\ & 0 & p_3(t) \end{array} \right)$$

<sup>2</sup><https://sites.google.com/view/vbrej>

for  $i = 1, 2, 3$ , respectively, where each  $p_i(t)$  is the square root of the untwisted Alexander polynomial  $\Delta_{K_i}(t)$ ,  $I$  is the identity matrix and  $*$  represents other entries. Specifically,

$$\begin{aligned} p_1(t) &= 1 - 3t + 7t^2 - 10t^3 + 11t^4 - 10t^5 + 7t^6 - 3t^7 + t^8, \\ p_2(t) &= 1 - 3t + 6t^2 - 9t^3 + 11t^4 - 9t^5 + 6t^6 - 3t^7 + t^8, \\ p_3(t) &= 1 - 4t + 8t^2 - 11t^3 + 13t^4 - 11t^5 + 8t^6 - 4t^7 + t^8. \end{aligned}$$

Recall that the Alexander module  $\mathcal{A}(K)$  of a knot  $K$  is the  $\mathbb{Z}[t^{\pm 1}]$ -module  $H_1(\widetilde{X}_K^\infty)$ , where  $\widetilde{X}_K^\infty$  is the infinite cyclic cover of the knot complement  $X_K$  and  $t$  acts by deck transformations. Choose a preferred copy of  $S^3 \setminus \nu(F_i)$  in  $\widetilde{X}_{K_i}^\infty$  for all  $i$ . From [8, Theorems 1.3 and 1.4], summarised in the present context in [1, Theorem 3.6], it follows that

$$\mathcal{A}(K_i) \cong \mathbb{Z}[t^{\pm 1}]/\langle p_i(t) \rangle \oplus \mathbb{Z}[t^{\pm 1}]/\langle p_i(t) \rangle,$$

where  $\mathcal{A}(K_i)$  for  $i \in \{1, 3\}$  is generated by the lifts of  $\hat{s}_{15}$  and  $\hat{s}_{16}$  to the preferred copy of  $S^3 \setminus \nu(F_i)$  in  $\widetilde{X}_i^\infty$ , while  $\mathcal{A}(K_2)$  is generated by the lifts of  $\hat{s}_{14}$  and  $\hat{s}_{16}$ ; in each case, call these generators  $a$  and  $b$ , respectively. Choose  $p = 3$ . By, e.g., [6, Section 6.1], we have

$$\begin{aligned} H_1(\Sigma_3(K_i)) &\cong \mathcal{A}(K_i)/\langle t^2 + t + 1 \rangle \\ &\cong \mathbb{Z}[t^{\pm 1}]/\langle p_i(t), t^2 + t + 1 \rangle \oplus \mathbb{Z}[t^{\pm 1}]/\langle p_i(t), t^2 + t + 1 \rangle \\ &\cong \mathbb{Z}[t^{\pm 1}]/\langle 7t, t^2 + t + 1 \rangle \oplus \mathbb{Z}[t^{\pm 1}]/\langle 7t, t^2 + t + 1 \rangle \\ &\cong (\mathbb{Z}/7)[t^{\pm 1}]/\langle t^2 + t + 1 \rangle \oplus (\mathbb{Z}/7)[t^{\pm 1}]/\langle t^2 + t + 1 \rangle \end{aligned}$$

in each of the three cases, since all of  $p_i(t)$  are congruent to  $7t$  modulo  $t^2 + t + 1$ . Hence, we fix  $q = 7$ . The generators of  $\mathcal{A}(K_i)$  descend to  $H_1(\Sigma_3(K_i))$ , so by abuse of notation we also denote them by  $a$  and  $b$ . As a group,  $H_1(\Sigma_3(K_i)) \cong (\mathbb{Z}/7)^4$ , and we may treat it as a  $(\mathbb{Z}/7)$ -module generated by  $a, ta, b$  and  $tb$ .

**4C. Blanchfield and linking forms.** From [8, Theorems 1.3, 1.4; 1, Theorem 3.6] and a calculation in the accompanying notebooks, we obtain that the Blanchfield pairings on  $\mathcal{A}(K_i)$  are given, with respect to the ordered basis  $\{a, b\}$  and after reducing both the numerators and denominators modulo  $t^3 - 1$ , by

$$\begin{aligned} \frac{1}{7} \begin{pmatrix} 2t^2 + 2t - 4 & -2t^2 + 4t - 2 \\ 4t^2 - 2t - 2 & -4t^2 - 4t + 8 \end{pmatrix}, & \quad \frac{1}{7} \begin{pmatrix} -3t^2 - 3t + 6 & 3t^2 - 3t \\ -3t^2 + 3t & 3t^2 + 3t - 6 \end{pmatrix}, \\ & \quad \frac{1}{7} \begin{pmatrix} -4t^2 - 4t + 8 & 4t^2 - 2t - 2 \\ -2t^2 + 4t - 2 & 2t^2 + 2t - 4 \end{pmatrix} \end{aligned}$$

for  $i = 1, 2, 3$ , respectively. Via [7, Chapter 2.6], applied similarly to [1, Proposition 3.7], we read off that the linking forms  $\lambda_i : H_1(\Sigma_3(K_i)) \times H_1(\Sigma_3(K_i)) \rightarrow \mathbb{Q}/\mathbb{Z}$

with respect to the ordered basis  $\{a, ta, b, tb\}$  are given by

$$\frac{1}{7} \begin{pmatrix} -4 & 2 & -2 & 4 \\ 2 & -4 & -2 & -2 \\ -2 & -2 & 1 & -4 \\ 4 & -2 & -4 & 1 \end{pmatrix}, \quad \frac{1}{7} \begin{pmatrix} 6 & -3 & 0 & -3 \\ -3 & 6 & 3 & 0 \\ 0 & 3 & -6 & 3 \\ -3 & 0 & 3 & -6 \end{pmatrix} \quad \text{and} \quad \frac{1}{7} \begin{pmatrix} 1 & -4 & -2 & -2 \\ -4 & 1 & 4 & -2 \\ -2 & 4 & -4 & 2 \\ -2 & -2 & 2 & -4 \end{pmatrix}.$$

**4D. Metabolisers of  $H_1(\Sigma_3(K_i))$ .** Write  $M = (\mathbb{Z}/7)[t^{\pm 1}]/\langle t^2 + t + 1 \rangle$  so that, as a  $(\mathbb{Z}/7)[t^{\pm 1}]$ -module,  $H_1(\Sigma_3(K_i)) \cong M \oplus M$ . Since the order  $|H_1(\Sigma_3(K_i))| = 7^4$ , we seek to describe all its  $\mathbb{Z}[t^{\pm 1}]$ -submodules of order  $7^2 = 49$ . Since  $t^2 + t + 1$  has irreducible factors  $(t - 2), (t + 3) \in (\mathbb{Z}/7)[t^{\pm 1}]$ , the set  $\{\langle 0 \rangle, \langle 1 \rangle, \langle t - 2 \rangle, \langle t + 3 \rangle\}$  contains precisely the  $(\mathbb{Z}/7)[t^{\pm 1}]$ -submodules of  $M$ ; since the  $\mathbb{Z}[t^{\pm 1}]$ -action on  $M$  factors through  $(\mathbb{Z}/7)[t^{\pm 1}]$ , these are also precisely the  $\mathbb{Z}[t^{\pm 1}]$ -submodules of  $M$ . Observe that  $|\langle 0 \rangle| = 1$ ,  $|\langle 1 \rangle| = 49$  and  $|\langle t - 2 \rangle| = |\langle t + 3 \rangle| = 7$ . Now let  $N$  be a  $\mathbb{Z}[t^{\pm 1}]$ -submodule of  $H_1(\Sigma_3(K_i))$ , and consider the commutative diagram

$$\begin{array}{ccccc} M \oplus \{0\} & \longrightarrow & M \oplus M & \xrightarrow{\pi} & \{0\} \oplus M \\ \uparrow & & \uparrow & & \uparrow \\ \ker \pi|_N & \longrightarrow & N & \xrightarrow{\pi|_N} & \text{im } \pi|_N \end{array}$$

where  $\pi(x, y) = (0, y)$  for all  $x, y \in M$ , and unlabelled arrows are inclusions;  $\ker \pi|_N$  and  $\text{im } \pi|_N$  are submodules of  $M \oplus \{0\}$  and  $\{0\} \oplus M$ , respectively. Since  $|N| = |\ker \pi|_N| \cdot |\text{im } \pi|_N|$ , we can deduce what  $N$  could be by order considerations.

- If  $|\ker \pi|_N| = 49$ , then  $|\text{im } \pi|_N| = 1$  and  $N = \ker \pi|_N = \text{span}_{(\mathbb{Z}/7)[t^{\pm 1}]} \{(1, 0)\}$ .
- If  $|\ker \pi|_N| = 1$ , then  $N \cong \text{im } \pi|_N = \text{span}_{(\mathbb{Z}/7)[t^{\pm 1}]} \{(k, 1)\}$  for some  $k \in (\mathbb{Z}/7)[t^{\pm 1}]$ .

Now, let  $\{\langle t - 2 \rangle, \langle t + 3 \rangle\} = \{\langle \alpha \rangle, \langle \beta \rangle\}$ ; we have  $\text{Ann } \alpha = \langle \beta \rangle$  and  $\text{Ann } \beta = \langle \alpha \rangle$ . There are two remaining cases to consider.

- Suppose  $\ker \pi|_N \cong \text{im } \pi|_N \cong \langle \alpha \rangle$ . Then  $N$  contains  $\{(\alpha, 0), (k, \alpha)\}$  for some  $k \in (\mathbb{Z}/7)[t^{\pm 1}]$ . Since  $\beta(k, \alpha) = (\beta k, 0) \in \ker \pi|_N$ , we must have  $\beta k \in \langle \alpha \rangle$ , so  $k \in \langle \alpha \rangle$ , i.e.,  $k = l\alpha$  for some  $l \in (\mathbb{Z}/7)[t^{\pm 1}]$ . Then  $-l(\alpha, 0) + (k, \alpha) = (0, \alpha) \in N$ , so  $N$  contains two linearly independent elements  $(\alpha, 0)$  and  $(0, \alpha)$  of order 7, and hence is generated by them for any choice of  $k$ . This yields two submodules  $N = \text{span}_{(\mathbb{Z}/7)[t^{\pm 1}]} \{(t - 2, 0), (0, t - 2)\}$  and  $N = \text{span}_{(\mathbb{Z}/7)[t^{\pm 1}]} \{(t + 3, 0), (0, t + 3)\}$ .
- Suppose  $\ker \pi|_N = \langle \alpha \rangle$  and  $\text{im } \pi|_N \cong \langle \beta \rangle$ . We similarly observe that  $N$  contains  $\{(\alpha, 0), (k, \beta)\}$  for some  $k \in (\mathbb{Z}/7)[t^{\pm 1}]$ . We have  $\alpha(k, \beta) = (\alpha k, 0) \in \ker \pi|_N$ , so we can take  $k$  modulo  $\alpha$ , i.e.,  $k \in \mathbb{Z}/7$ . Then  $\{(\alpha, 0), (k, \beta)\}$  is a linearly independent set generating  $N$  for any choice of  $k \in \mathbb{Z}/7$ . Thus,  $N = \text{span}_{(\mathbb{Z}/7)[t^{\pm 1}]} \{(t - 2, 0), (k, t + 3)\}$  or  $N = \text{span}_{(\mathbb{Z}/7)[t^{\pm 1}]} \{(t + 3, 0), (k, t - 2)\}$  for  $k \in \mathbb{Z}/7$ .



$K_1$	$K_2$	$K_3$
$\chi_6^{\alpha\beta} : (1, 2, 1, -2)$	$\chi_1^{\alpha\beta} : (1, 2, 1, -4)$	$\chi_2^{\alpha\beta} = \chi_0^\alpha : (1, 2, 1, 2)$
$\chi_4^{\beta\alpha} : (1, -3, 1, -2)$	$\chi_1^{\beta\alpha} : (1, -3, 1, 1)$	$\chi_3^{\beta\alpha} : (1, -3, 1, 1)$

**Table 2.** Our choice of characters  $\chi : H_1(\Sigma_3(K_i)) \rightarrow \mathbb{Z}/7$  vanishing on the metabolisers of  $K_1$ ,  $K_2$  and  $K_3$ ; the characters  $\chi_0^\alpha$  and  $\chi_0^\beta$  are given for all  $K_i$  by  $(1, 2, 1, 2)$  and  $(1, -3, 1, -3)$ .

To summarise, writing elements of  $H_1(\Sigma_3(K_i)) \cong M \oplus M$  additively with the first copy of  $M$  generated by  $a$  and the second by  $b$ , the desired submodules are

$$\begin{aligned}
N_0 &= \text{span}_{(\mathbb{Z}/7)[t^{\pm 1}]} \{a\}, \\
N_{k_0, k_1} &= \text{span}_{(\mathbb{Z}/7)[t^{\pm 1}]} \{ka + b\} \text{ for } k \in (\mathbb{Z}/7)[t^{\pm 1}] \\
&= \text{span}_{(\mathbb{Z}/7)[t^{\pm 1}]} \{(k_0 + k_1 t)a + b\} \text{ for } k_0, k_1 \in \mathbb{Z}/7, \\
N_0^\alpha &= \text{span}_{(\mathbb{Z}/7)[t^{\pm 1}]} \{(t-2)a, (t-2)b\}, \\
N_0^\beta &= \text{span}_{(\mathbb{Z}/7)[t^{\pm 1}]} \{(t+3)a, (t+3)b\}, \\
N_{k_0}^{\alpha\beta} &= \text{span}_{(\mathbb{Z}/7)[t^{\pm 1}]} \{(t-2)a, k_0 a + (t+3)b\} \text{ for } k_0 \in \mathbb{Z}/7, \\
N_{k_0}^{\beta\alpha} &= \text{span}_{(\mathbb{Z}/7)[t^{\pm 1}]} \{(t+3)a, k_0 a + (t-2)b\} \text{ for } k_0 \in \mathbb{Z}/7.
\end{aligned}$$

By a direct computation carried out in the accompanying notebooks, the submodules  $N_0^\alpha$  and  $N_0^\beta$  are metabolisers for  $K_i$  for all  $i$ ; in addition,  $K_1$  has metabolisers  $N_6^{\alpha\beta}$  and  $N_4^{\beta\alpha}$ ,  $K_2$  has metabolisers  $N_1^{\alpha\beta}$  and  $N_1^{\beta\alpha}$ , and  $K_3$  has metabolisers  $N_2^{\alpha\beta}$  and  $N_3^{\beta\alpha}$ .

**4E. Characters vanishing on the metabolisers.** It is easy to define characters  $\chi : H_1(\Sigma_3(K_i)) \rightarrow \mathbb{Z}/7$  that vanish on the metabolisers. Let subscripts and superscripts denote corresponding metabolisers and 4-tuples in parentheses represent the values a character takes on the ordered basis  $\{a, ta, b, tb\}$ . Then we can take  $\chi_0^\alpha$  and  $\chi_0^\beta$  as defined by  $(1, 2, 1, 2)$  and  $(1, -3, 1, -3)$ , respectively. The rest of the characters are presented in [Table 2](#).

**4F. Representations of the knot groups into  $\text{GL}(3, \mathbb{Q}(\zeta_7)[t^{\pm 1}])$ .** Let

$$K \in \{K_1, K_2, K_3\}.$$

We follow [\[1, Appendix A\]](#) and [\[11, Chapters 5–7\]](#) to construct representations

$$\varphi_\chi : \pi_1(X_K) \rightarrow \text{GL}(3, \mathbb{Q}(\zeta_7)[t^{\pm 1}])$$

of the knot group of  $K$  that determine twisted Alexander polynomials for each character in [Table 2](#). Fix a basepoint  $x_0$  in  $S^3 \setminus \nu(F)$  and let  $\tilde{x}_0$  be its lift to the

preferred copy of  $S^3 \setminus \nu(F)$  in  $\widetilde{X}_K^3$ , the triple cyclic cover of the knot complement  $X_K$ . Also fix a based meridian  $\mu_0$  in  $S^3 \setminus K$  and let  $\varepsilon : \pi_1(X_K) \rightarrow \mathbb{Z}$  be the abelianisation homomorphism. Define a map  $l : \ker \varepsilon \rightarrow H_1(\Sigma_3(K))$  that takes a simple closed curve  $\gamma \subset S^3 \setminus K$  based at  $x_0$  with  $\text{lk}(K, \gamma) = 0$  to the homology class of the well-defined lift  $\tilde{\gamma}$  in  $\widetilde{X}_K^3 \subset \Sigma_3(K)$  based at  $\tilde{x}_0$ . In particular,  $l$  has the property that for any  $\gamma \in \ker \varepsilon$ , we have

$$(\ddagger) \quad l(\mu_0 \gamma \mu_0^{-1}) = t \cdot l(\gamma).$$

Now consider the semidirect product  $\mathbb{Z} \ltimes H_1(\Sigma_3(K))$ , with  $\mathbb{Z} = \langle t \rangle$ , whose product structure is given by  $(t^{m_1}, x_1) \cdot (t^{m_2}, x_2) = (t^{m_1+m_2}, t^{-m_2} \cdot x_1 + x_2)$  with  $t$  acting on elements of  $H_1(\Sigma_3(K))$  by deck transformations. Fix a Wirtinger presentation of  $\pi_1(X_K) \cong \langle g_1, \dots, g_n \mid r_1, \dots, r_n \rangle$  and define a homomorphism

$$\psi : \pi_1(X_K) \rightarrow \mathbb{Z} \ltimes H_1(\Sigma_3(K)), \quad g_i \mapsto (t, l(\mu_0^{-1} g_i)) =: (t, v_i)$$

on the generators of  $\pi_1(X_K)$ , since clearly  $\mu_0^{-1} g_i \in \ker \varepsilon$ . Observe that a relation  $g_i g_j g_i^{-1} g_k^{-1} = 1$  imposes, via the group structure on  $\mathbb{Z} \ltimes H_1(\Sigma_3(K))$ , the condition

$$(\ddagger\ddagger) \quad (1-t)v_i + tv_j - v_k = 0.$$

Finally, for a character  $\chi : H_1(\Sigma_3(K)) \rightarrow \mathbb{Z}/7$ , we obtain a representation

$$\varphi_\chi : \pi_1(X_K) \rightarrow \text{GL}(3, \mathbb{Q}(\zeta_7)[t^{\pm 1}])$$

by setting  $\varphi_\chi = \tau_\chi \circ \psi$ , where

$$\tau_\chi : \mathbb{Z} \ltimes H_1(\Sigma_3(K)) \rightarrow \text{GL}(3, \mathbb{Q}(\zeta_7)[t^{\pm 1}]),$$

$$(t^m, v) \mapsto \begin{pmatrix} 0 & 1 & 0 \\ 0 & 0 & 1 \\ t & 0 & 0 \end{pmatrix}^m \begin{pmatrix} \zeta_7^{\chi(v)} & 0 & 0 \\ 0 & \zeta_7^{\chi(t \cdot v)} & \\ 0 & 0 & \zeta_7^{\chi(t^2 \cdot v)} \end{pmatrix}.$$

We shall apply the equation  $(\ddagger)$  to determine the form of the first few  $v_k$  for  $K$  in terms of the generators  $\{a, b\}$  of  $H_1(\Sigma_3(K))$  and then deduce the rest of  $v_k$  using  $(\ddagger\ddagger)$ , giving us the desired  $\varphi_\chi$ . We illustrate the process in more detail for  $K_1$ , with  $K_2$  and  $K_3$  cases being analogous.

Recall that we orient  $K_1$  clockwise. Index the arcs in the diagram of  $K_1$  as shown in [Figure 10](#), starting with 1 at the top left and increasing the index at every undercrossing. This yields the following Wirtinger presentation of  $\pi_1(X_1)$ , with generators being the meridians  $g_i$  about each arc  $i$  based at  $x_0$ :

$$\pi_1(X_1) = \left\langle g_1, \dots, g_{18} \mid \begin{array}{l} g_1 g_{13} g_8^{-1} g_{12}^{-1}, g_3 g_{17} g_3^{-1} g_{16}^{-1}, g_7 g_{18} g_7^{-1} g_{18}^{-1}, g_{16} g_9 g_{16}^{-1} g_{10}^{-1}, \\ g_{13} g_2 g_{13}^{-1} g_1^{-1}, g_{17} g_5 g_{17}^{-1} g_4^{-1}, g_8 g_{13} g_8^{-1} g_{14}^{-1}, g_{10} g_3 g_{10}^{-1} g_4^{-1}, g_6 g_{11} g_6^{-1} g_{12}^{-1}, \\ g_2 g_{15} g_2^{-1} g_{14}^{-1}, g_5 g_{18} g_5^{-1} g_{17}^{-1}, g_{14} g_8 g_{14}^{-1} g_9^{-1}, g_4 g_{10} g_4^{-1} g_{11}^{-1}, g_{12} g_7 g_{12}^{-1} g_8^{-1}, \\ g_{15} g_3 g_{15}^{-1} g_2^{-1}, g_{18} g_7 g_{18}^{-1} g_6^{-1}, g_9 g_{15} g_9^{-1} g_{16}^{-1}, g_{11} g_5 g_{11}^{-1} g_6^{-1}, \end{array} \right\rangle$$

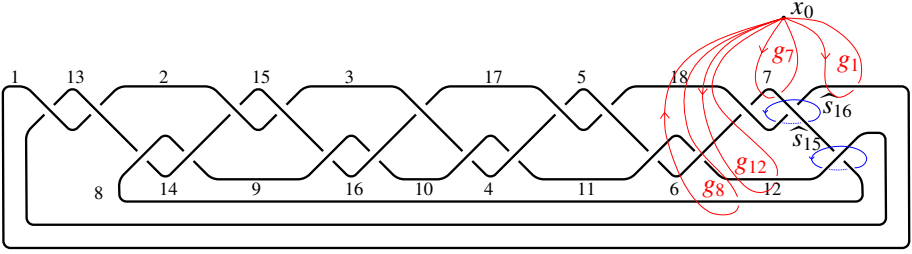

**Figure 10.** Choice of arc labels for  $K_1$  giving the Wirtinger presentation of  $\pi_1(X_1)$ .

Observe that  $\hat{s}_{15} = g_8 g_{12}^{-1}$  and  $\hat{s}_{16} = g_1^{-1} g_7$ . Fix  $\mu_0 = g_1$ . Then  $v_1 = l(g_1^{-1} g_1) = 0$  and  $v_7 = l(g_1^{-1} g_7) = b$ . Also, using the property  $(\ddagger)$ , we have

$$\begin{aligned} a &= l(g_8 g_{12}^{-1}) = l(g_8 g_1^{-1} g_1 g_{12}^{-1}) = l(g_8 g_1^{-1}) + l(g_1 g_{12}^{-1}) \\ &= l(g_1 g_1^{-1} g_8 g_1^{-1}) - l(g_{12} g_1^{-1}) \\ &= l(g_1 g_1^{-1} g_8 g_1^{-1}) - l(g_1 g_1^{-1} g_{12} g_1^{-1}) = tv_8 - tv_{12}. \end{aligned}$$

Applying  $(\ddagger\ddagger)$  to the relation  $g_{12} g_7 g_{12}^{-1} g_8^{-1} = 1$  and recalling we are working modulo  $t^2 + t + 1$ , we get

$$\begin{aligned} (1 - t)v_{12} + tv_7 - v_8 &= 0 \implies (1 - t)v_{12} - v_8 = -tb \mid \cdot (-t) \\ &\implies (tv_8 - tv_{12}) + t^2 v_{12} = t^2 b \\ &\implies a + t^2 v_{12} = t^2 b \mid \cdot t \\ &\implies v_{12} = -ta + b. \end{aligned}$$

Now we can use  $(\ddagger\ddagger)$  repeatedly to obtain the values of all  $v_i$ . With the same conventions and the choice  $\mu_0 = g_1$ , for  $K_2$  we have

$$l(\hat{s}_{14}) = l(g_1^{-1} g_6) = a \quad \text{and} \quad l(\hat{s}_{16}) = l(g_{14} g_7^{-1}) = b,$$

while for  $K_3$ ,

$$l(\hat{s}_{15}) = l(g_1^{-1} g_7) = a \quad \text{and} \quad l(\hat{s}_{16}) = l(g_8 g_{13}^{-1}) = b;$$

this lets us calculate the values of  $v_i$  in [Table 3](#) analogously. With that, constructing representations  $\varphi_\chi$  for the characters in [Section 4E](#) is mechanical.

**4G. Calculating twisted Alexander polynomials.** Again, let  $K \in \{K_1, K_2, K_3\}$  and fix the Wirtinger presentation of  $\pi_1(X_K)$  as in [Section 4F](#). Given a representation  $\varphi_\chi : \pi_1(X_K) \rightarrow \text{GL}(3, \mathbb{Q}(\zeta_7)[t^{\pm 1}])$ , let  $\Phi : \mathbb{Z}[\pi_1(X_K)] \rightarrow \text{Mat}_3(\mathbb{Q}(\zeta_7)[t^{\pm 1}])$  be its natural extension to the group ring  $\mathbb{Z}[\pi_1(X_K)]$  taking values in the set of  $3 \times 3$

matrices with  $\mathbb{Q}(\zeta_7)[t^{\pm 1}]$  coefficients. Let

$$\Psi = \left( \frac{\partial r_i}{\partial g_j} \right)_{i,j=1,\dots,18}$$

be the Fox matrix for the Wirtinger presentation of  $\pi_1(X_K)$ ; the row of  $\Psi$  corresponding to the relation  $g_i g_j g_i^{-1} g_k^{-1}$  has  $1 - g_k$  in the  $i$ -th column,  $g_i$  in the  $j$ -th column,  $-1$  in the  $k$ -th column and zeros elsewhere. Write  $r(\Psi)$  for the reduced Fox matrix obtained by dropping the first row and column from  $\Psi$  and let  $\Phi_\chi$  be the  $51 \times 51$  matrix obtained by applying  $\Phi$  to  $r(\Psi)$  entrywise. By [11, Section 9], the reduced twisted Alexander polynomial  $\tilde{\Delta}_K^\chi(t)$  of  $(K, \chi)$  (for nontrivial  $\chi$ ) is given by

$$\tilde{\Delta}_K^\chi(t) = \frac{\det \Phi_\chi}{(t-1) \det(\varphi_\chi(g_1) - I)}.$$

Thus we obtain the 11 reduced twisted Alexander polynomials listed in the [Appendix](#) associated with our characters of interest.

**4H. Obstructing sliceness of  $K_i$ .** To show that  $K_1$ ,  $K_2$  and  $K_3$  are not slice, we use the following generalisation of the Fox–Milnor condition, due to Kirk and Livingston [12].

	$\pi_1(X_1)$	$\pi_1(X_2)$	$\pi_1(X_3)$
$v_1$	0	0	0
$v_2$	$(6t+5)a + (5t+6)b$	$(5t+6)a + (4t+4)b$	$(5t+6)a + (6t+5)b$
$v_3$	$5ta + 5b$	$3a + (3t+1)b$	$(4t+3)a + (t+1)b$
$v_4$	$(2t+5)a + 6b$	$(2t+6)a + 2b$	$(6t+3)a + b$
$v_5$	$(6t+5)a + (5t+3)b$	$(4t+1)a + (6t+5)b$	$(6t+4)a + (4t+6)b$
$v_6$	$5tb$	$a$	$(4t+1)a + (t+6)b$
$v_7$	$b$	$a + (6t+1)b$	$a$
$v_8$	$(5t+6)a + b$	$(6t+6)a + (6t+5)b$	$a + (5t+6)b$
$v_9$	$(3t+2)a + (4t+1)b$	$5ta + (3t+5)b$	$(3t+6)a + (5t+3)b$
$v_{10}$	$(t+2)a + (5t+1)b$	$(2t+3)a + (3t+3)b$	$(4t+6)a + (3t+3)b$
$v_{11}$	$6a + (4t+1)b$	$(3t+6)a + 5b$	$(3t+6)a + 2tb$
$v_{12}$	$6ta + b$	$(6t+2)a + (6t+6)b$	$(6t+2)a + 6b$
$v_{13}$	$6a + (6t+6)b$	$a + b$	$a + 6tb$
$v_{14}$	$(3t+4)a + (6t+2)b$	$a + 5tb$	$(6t+6)a + 6b$
$v_{15}$	$3a + (2t+4)b$	$(5t+3)a + 6b$	$(6t+2)a + (3t+4)b$
$v_{16}$	$5a + (2t+3)b$	$(5t+5)a + (3t+5)b$	$(t+1)a + (2t+6)b$
$v_{17}$	$4a + (2t+2)b$	$ta + (5t+3)b$	$ta + (2t+5)b$
$v_{18}$	$(6t+1)b$	$(6t+1)a$	$(6t+1)a$

**Table 3.** Values of  $v_k = l(\mu_0^{-1} g_k) \in H_1(\Sigma_3(K_i))$ .

**Theorem 4.1** [12, Proposition 6.1]. *Let  $K \subset S^3$  be a slice knot and fix distinct primes  $p$  and  $q$ . Then there exists a covering transformation invariant metaboliser  $N$  in  $H_1(\Sigma_p(K))$  such that the following condition holds: for every character  $\chi : H_1(\Sigma_p(K)) \rightarrow \mathbb{Z}/q$  that vanishes on  $N$ , the associated reduced twisted Alexander polynomial  $\tilde{\Delta}_K^\chi(t) \in \mathbb{Q}(\zeta_q)[t^{\pm 1}]$  is a **norm**, i.e.,  $\tilde{\Delta}_K^\chi(t)$  can be written as*

$$\tilde{\Delta}_K^\chi(t) = \lambda t^k f(t) \overline{f(t)}$$

for some  $\lambda \in \mathbb{Q}(\zeta_q)$ ,  $k \in \mathbb{Z}$  and  $\overline{f(t)}$  obtained from  $f(t) \in \mathbb{Q}(\zeta_q)[t^{\pm 1}]$  by the involution  $t \mapsto t^{-1}$ ,  $\zeta_q \mapsto \zeta_q^{-1}$ .

Using the routine implemented in SnapPy [4] for determining whether an element of  $\mathbb{Q}(\zeta_q)[t^{\pm 1}]$  is a norm, which relies on the SageMath algorithm for factoring polynomials over cyclotomic fields, we conclude via a calculation in the accompanying notebooks that none of the 11 polynomials in the [Appendix](#) are norms. This implies that  $K_1$ ,  $K_2$  and  $K_3$  are not slice.

### Appendix: Reduced twisted Alexander polynomials for $K_1$ , $K_2$ and $K_3$

The following table contains reduced twisted Alexander polynomials for knots  $K_1$ ,  $K_2$  and  $K_3$  associated to characters vanishing on the metabolisers of respective knots; for brevity, we write  $\zeta = \zeta_7$  and  $\theta = \zeta_7 + \zeta_7^2 + \zeta_7^4$ .

$(K_i, \chi)$	$\tilde{\Delta}_{K_i}^\chi(t)$
$(K_1, \chi_0^\alpha)$	$  \begin{aligned}  & -t^{15} + (-2\theta - 1)t^{14} + (-8\theta - 3)t^{13} + 15t^{12} + (-3\theta + 48)t^{11} \\  & \quad + (-8\theta + 33)t^{10} + (-48\theta + 34)t^9 + 199t^8 + (48\theta + 82)t^7 \\  & \quad + (8\theta + 41)t^6 + (3\theta + 51)t^5 + 15t^4 + (8\theta + 5)t^3 + (2\theta + 1)t^2 - t  \end{aligned}  $
$(K_1, \chi_0^\beta)$	$  \begin{aligned}  & -t^{15} + (-4\theta + 5)t^{14} + (24\theta - 15)t^{13} + (-93\theta - 14)t^{12} + (98\theta + 11)t^{11} \\  & \quad + (-2\theta + 71)t^{10} + (-11\theta - 154)t^9 + 360t^8 + (11\theta - 143)t^7 + (2\theta + 73)t^6 \\  & \quad + (-98\theta - 87)t^5 + (93\theta + 79)t^4 + (-24\theta - 39)t^3 + (4\theta + 9)t^2 - t  \end{aligned}  $
$(K_1, \chi_6^{\alpha\beta})$	$  \begin{aligned}  & -t^{15} + (2\zeta^5 - \zeta^4 + 4\zeta^3 - \zeta^2 - 2\zeta + 5)t^{14} \\  & \quad + (-3\zeta^5 + 7\zeta^4 - 24\zeta^3 - 3\zeta^2 + 2\zeta - 20)t^{13} \\  & \quad + (7\zeta^5 - 67\zeta^4 + 41\zeta^3 - 8\zeta^2 - 35\zeta + 7)t^{12} \\  & \quad + (-45\zeta^5 + 52\zeta^4 - 38\zeta^3 + 3\zeta^2 - \zeta + 19)t^{11} \\  & \quad + (68\zeta^5 + 51\zeta^4 + 114\zeta^3 + 24\zeta^2 + 95\zeta + 63)t^{10} \\  & \quad + (116\zeta^5 + 121\zeta^4 + 80\zeta^3 + 56\zeta^2 + 124\zeta + 65)t^9 \\  & \quad + (149\zeta^5 - 3\zeta^4 - 3\zeta^3 + 149\zeta^2 + 19)t^8 \\  & \quad + (-68\zeta^5 - 44\zeta^4 - 3\zeta^3 - 8\zeta^2 - 124\zeta - 59)t^7 \\  & \quad + (-71\zeta^5 + 19\zeta^4 - 44\zeta^3 - 27\zeta^2 - 95\zeta - 32)t^6 \\  & \quad + (4\zeta^5 - 37\zeta^4 + 53\zeta^3 - 44\zeta^2 + \zeta + 20)t^5 \\  & \quad + (27\zeta^5 + 76\zeta^4 - 32\zeta^3 + 42\zeta^2 + 35\zeta + 42)t^4 \\  & \quad + (-5\zeta^5 - 26\zeta^4 + 5\zeta^3 - 5\zeta^2 - 2\zeta - 22)t^3 \\  & \quad + (\zeta^5 + 6\zeta^4 + \zeta^3 + 4\zeta^2 + 2\zeta + 7)t^2 - t  \end{aligned}  $

$$\begin{aligned}
(K_1, \chi_4^{\beta\alpha}) \quad & -t^{15} + (2\zeta^5 + \zeta^4 + 2\zeta^3 + \zeta^2 - \zeta + 2)t^{14} \\
& + (-5\zeta^5 - 2\zeta^4 - 3\zeta^3 - 6\zeta^2 - 2\zeta - 9)t^{13} + (10\zeta^5 + 4\zeta^4 + 9\zeta^2 + 20)t^{12} \\
& + (-35\zeta^5 - 36\zeta^4 - 30\zeta^3 - 35\zeta^2 - 4\zeta - 10)t^{11} \\
& + (44\zeta^5 - 10\zeta^4 + 8\zeta^3 + 47\zeta^2 + 52\zeta + 85)t^{10} \\
& + (-57\zeta^5 - 17\zeta^4 - 63\zeta^3 + 29\zeta^2 - 27\zeta + 11)t^9 \\
& + (7\zeta^5 + 38\zeta^4 + 38\zeta^3 + 7\zeta^2 - 59)t^8 \\
& + (56\zeta^5 - 36\zeta^4 + 10\zeta^3 - 30\zeta^2 + 27\zeta + 38)t^7 \\
& + (-5\zeta^5 - 44\zeta^4 - 62\zeta^3 - 8\zeta^2 - 52\zeta + 33)t^6 \\
& + (-31\zeta^5 - 26\zeta^4 - 32\zeta^3 - 31\zeta^2 + 4\zeta - 6)t^5 + (9\zeta^5 + 4\zeta^3 + 10\zeta^2 + 20)t^4 \\
& + (-4\zeta^5 - \zeta^4 - 3\zeta^2 + 2\zeta - 7)t^3 + (2\zeta^5 + 3\zeta^4 + 2\zeta^3 + 3\zeta^2 + \zeta + 3)t^2 - t \\
(K_2, \chi_0^\alpha) \quad & t^{15} + (-\theta - 2)t^{14} + (-2\theta - 1)t^{13} + (3\theta + 3)t^{12} + (-13\theta - 22)t^{11} \\
& + (-15\theta - 5)t^{10} + (25\theta + 13)t^9 - 82t^8 + (-25\theta - 12)t^7 + (15\theta + 10)t^6 \\
& + (13\theta - 9)t^5 - 3\theta t^4 + (2\theta + 1)t^3 + (\theta - 1)t^2 + t \\
(K_2, \chi_0^\beta) \quad & t^{15} + (-4\theta - 7)t^{14} + (16\theta + 15)t^{13} + (-41\theta - 26)t^{12} + (55\theta + 5)t^{11} \\
& + (-20\theta - 18)t^{10} + (-25\theta + 114)t^9 - 292t^8 + (25\theta + 139)t^7 + (20\theta + 2)t^6 \\
& + (-55\theta - 50)t^5 + (41\theta + 15)t^4 + (-16\theta - 1)t^3 + (4\theta - 3)t^2 + t \\
(K_2, \chi_1^{\alpha\beta}) \quad & t^{15} + (-3\zeta^5 + 3\zeta^4 - 2\zeta^3 + \zeta^2 - 4)t^{14} + (4\zeta^5 - 12\zeta^4 + 6\zeta^3 - 13\zeta^2 + \zeta)t^{13} \\
& + (23\zeta^4 + 9\zeta^3 + 30\zeta^2 - 4\zeta + 17)t^{12} \\
& + (-49\zeta^5 - 17\zeta^4 - 50\zeta^3 - 46\zeta^2 - 33\zeta - 13)t^{11} \\
& + (-48\zeta^5 + 5\zeta^4 + 67\zeta^3 - 34\zeta^2 + 87\zeta - 36)t^{10} \\
& + (164\zeta^5 + 69\zeta^4 + 127\zeta^3 + 39\zeta^2 + 83\zeta + 75)t^9 \\
& + (173\zeta^5 + 32\zeta^4 + 32\zeta^3 + 173\zeta^2 + 166)t^8 \\
& + (-44\zeta^5 + 44\zeta^4 - 14\zeta^3 + 81\zeta^2 - 83\zeta - 8)t^7 \\
& + (-121\zeta^5 - 20\zeta^4 - 82\zeta^3 - 135\zeta^2 - 87\zeta - 123)t^6 \\
& + (-13\zeta^5 - 17\zeta^4 + 16\zeta^3 - 16\zeta^2 + 33\zeta + 20)t^5 \\
& + (34\zeta^5 + 13\zeta^4 + 27\zeta^3 + 4\zeta^2 + 4\zeta + 21)t^4 \\
& + (-14\zeta^5 + 5\zeta^4 - 13\zeta^3 + 3\zeta^2 - \zeta - 1)t^3 + (\zeta^5 - 2\zeta^4 + 3\zeta^3 - 3\zeta^2 - 4)t^2 + t \\
(K_2, \chi_1^{\beta\alpha}) \quad & t^{15} + (-\zeta^5 - 2\zeta^4 + \zeta^2 - 3\zeta - 7)t^{14} + (4\zeta^5 + 8\zeta^4 - 4\zeta^3 - 4\zeta^2 + 17\zeta + 28)t^{13} \\
& + (-\zeta^5 - 20\zeta^4 + 21\zeta^3 + 30\zeta^2 - 52\zeta - 78)t^{12} \\
& + (-10\zeta^5 + 38\zeta^4 - 51\zeta^3 - 88\zeta^2 + 122\zeta + 187)t^{11} \\
& + (81\zeta^5 - 15\zeta^4 + 87\zeta^3 + 205\zeta^2 - 155\zeta - 358)t^{10} \\
& + (-256\zeta^5 - 31\zeta^4 - 157\zeta^3 - 312\zeta^2 + 91\zeta + 487)t^9 \\
& + (434\zeta^5 + 146\zeta^4 + 146\zeta^3 + 434\zeta^2 - 430)t^8 \\
& + (-403\zeta^5 - 248\zeta^4 - 122\zeta^3 - 347\zeta^2 - 91\zeta + 396)t^7 \\
& + (360\zeta^5 + 242\zeta^4 + 140\zeta^3 + 236\zeta^2 + 155\zeta - 203)t^6 \\
& + (-210\zeta^5 - 173\zeta^4 - 84\zeta^3 - 132\zeta^2 - 122\zeta + 65)t^5 \\
& + (82\zeta^5 + 73\zeta^4 + 32\zeta^3 + 51\zeta^2 + 52\zeta - 26)t^4 \\
& + (-21\zeta^5 - 21\zeta^4 - 9\zeta^3 - 13\zeta^2 - 17\zeta + 11)t^3 \\
& + (4\zeta^5 + 3\zeta^4 + \zeta^3 + 2\zeta^2 + 3\zeta - 4)t^2 + t
\end{aligned}$$

$$\begin{aligned}
(K_3, \chi_0^\alpha) & t^{15} + (\theta - 3)t^{14} + (-3\theta - 1)t^{13} + (-2\theta - 22)t^{12} + (-73\theta - 8)t^{11} \\
= (K_3, \chi_2^{\alpha\beta}) & + (10\theta + 239)t^{10} + (362\theta + 223)t^9 - 675t^8 + (-362\theta - 139)t^7 \\
& + (-10\theta + 229)t^6 + (73\theta + 65)t^5 + (2\theta - 20)t^4 + (3\theta + 2)t^3 + (-\theta - 4)t^2 + t \\
(K_3, \chi_0^\beta) & t^{15} - 7t^{14} + (-2\theta + 17)t^{13} + (6\theta - 32)t^{12} + (-26\theta + 26)t^{11} \\
& + (24\theta + 8)t^{10} + (40\theta + 83)t^9 - 178t^8 + (-40\theta + 43)t^7 + (-24\theta - 16)t^6 \\
& + (26\theta + 52)t^5 + (-6\theta - 38)t^4 + (2\theta + 19)t^3 - 7t^2 + t \\
(K_3, \chi_3^{\beta\alpha}) & t^{15} + (-\zeta^5 + 3\zeta^4 + 2\zeta^3 + 2\zeta^2 + 4\zeta - 3)t^{14} \\
& + (18\zeta^5 + \zeta^4 + 3\zeta^3 + 3\zeta^2 - 4\zeta + 11)t^{13} \\
& + (-33\zeta^5 - 17\zeta^4 - 26\zeta^3 - 21\zeta^2 - 11\zeta - 60)t^{12} \\
& + (-5\zeta^5 - 52\zeta^4 - 16\zeta^3 - 3\zeta^2 - 56\zeta + 45)t^{11} \\
& + (-14\zeta^5 + 48\zeta^4 + 66\zeta^3 - 18\zeta^2 + 59\zeta - 5)t^{10} \\
& + (106\zeta^5 + 89\zeta^4 - 10\zeta^3 + 109\zeta^2 + 18\zeta + 101)t^9 \\
& + (-133\zeta^5 - 123\zeta^4 - 123\zeta^3 - 133\zeta^2 - 212)t^8 \\
& + (91\zeta^5 - 28\zeta^4 + 71\zeta^3 + 88\zeta^2 - 18\zeta + 83)t^7 \\
& + (-77\zeta^5 + 7\zeta^4 - 11\zeta^3 - 73\zeta^2 - 59\zeta - 64)t^6 \\
& + (53\zeta^5 + 40\zeta^4 + 4\zeta^3 + 51\zeta^2 + 56\zeta + 101)t^5 \\
& + (-10\zeta^5 - 15\zeta^4 - 6\zeta^3 - 22\zeta^2 + 11\zeta - 49)t^4 \\
& + (7\zeta^5 + 7\zeta^4 + 5\zeta^3 + 22\zeta^2 + 4\zeta + 15)t^3 \\
& + (-2\zeta^5 - 2\zeta^4 - \zeta^3 - 5\zeta^2 - 4\zeta - 7)t^2 + t
\end{aligned}$$

### Acknowledgements

We thank our supervisors Brendan Owens and Andy Wand for many helpful discussions and advice, Frank Swenton for his KLO software which we have found very useful, and Ross Paterson for consultation on some algebra. We are grateful to Paolo Aceto, Marco Golla, Kyle Larson, Ana Lecuona, Paolo Lisca, Allison Miller, Maggie Miller and Jonathan Simone for their comments on an earlier draft of this paper. This work was funded by the Carnegie Trust.

### References

- [1] P. Aceto, J. Meier, A. N. Miller, M. Miller, J. Park, and A. I. Stipsicz, “Branched covers bounding rational homology balls”, *Algebr. Geom. Topol.* **21**:7 (2021), 3569–3599. [MR](#) [Zbl](#)
- [2] J. Collins, “An algorithm for computing the Seifert matrix of a link from a braid representation”, pp. 246–262 in *Six papers on signatures, braids and Seifert surfaces*, *Ensaos Mat.* **30**, Soc. Brasil. Mat., Rio de Janeiro, 2016. [MR](#) [Zbl](#)
- [3] P. R. Cromwell, “Homogeneous links”, *J. London Math. Soc.* (2) **39**:3 (1989), 535–552. [MR](#) [Zbl](#)
- [4] M. Culler, N. M. Dunfield, M. Goerner, and J. R. Weeks, “SnapPy, a computer program for studying the geometry and topology of 3-manifolds”, available at <http://snappy.computop.org>.
- [5] A. Donald and B. Owens, “Concordance groups of links”, *Algebr. Geom. Topol.* **12**:4 (2012), 2069–2093. [MR](#) [Zbl](#)

- [6] P. Feller and L. Lewark, “Balanced algebraic unknotting, linking forms, and surfaces in three- and four-space”, preprint, 2019. [arXiv 1905.08305](#)
- [7] S. K. Friedl, *Eta invariants as sliceness obstructions and their relation to Casson–Gordon invariants*, Ph.D. thesis, Brandeis University, 2003, available at <https://www.proquest.com/docview/305344481>. [MR](#) [Zbl](#)
- [8] S. Friedl and M. Powell, “A calculation of Blanchfield pairings of 3-manifolds and knots”, *Mosc. Math. J.* **17**:1 (2017), 59–77. [MR](#) [Zbl](#)
- [9] S. Friedl and S. Vidussi, “A survey of twisted Alexander polynomials”, pp. 45–94 in *The mathematics of knots*, Contrib. Math. Comput. Sci. **1**, Springer, Heidelberg, 2011. [MR](#) [Zbl](#)
- [10] C. M. Gordon and R. A. Litherland, “On the signature of a link”, *Invent. Math.* **47**:1 (1978), 53–69. [MR](#)
- [11] C. Herald, P. Kirk, and C. Livingston, “Metabelian representations, twisted Alexander polynomials, knot slicing, and mutation”, *Math. Z.* **265**:4 (2010), 925–949. [MR](#) [Zbl](#)
- [12] P. Kirk and C. Livingston, “Twisted Alexander invariants, Reidemeister torsion, and Casson–Gordon invariants”, *Topology* **38**:3 (1999), 635–661. [MR](#) [Zbl](#)
- [13] A. G. Lecuona, “On the slice-ribbon conjecture for Montesinos knots”, *Trans. Amer. Math. Soc.* **364**:1 (2012), 233–285. [MR](#) [Zbl](#)
- [14] P. Lisca, “Lens spaces, rational balls and the ribbon conjecture”, *Geom. Topol.* **11** (2007), 429–472. [MR](#) [Zbl](#)
- [15] P. Lisca, “On 3-braid knots of finite concordance order”, *Trans. Amer. Math. Soc.* **369**:7 (2017), 5087–5112. [MR](#) [Zbl](#)
- [16] B. Owens and F. Swenton, “An algorithm to find ribbon disks for alternating knots”, preprint, 2021. [arXiv 2102.11778](#)
- [17] P. Ozsváth and Z. Szabó, “Knot Floer homology and the four-ball genus”, *Geom. Topol.* **7** (2003), 615–639. [MR](#)
- [18] J. Rasmussen, “Khovanov homology and the slice genus”, *Invent. Math.* **182**:2 (2010), 419–447. [MR](#) [Zbl](#)
- [19] A. Sartori, *Polinomi di Alexander e nodi slice*, master’s thesis, University of Pisa, 2010, available at <https://etd.adm.unipi.it/theses/available/etd-06012010-091442/unrestricted/tesi.pdf>.
- [20] J. Simone, “Classification of torus bundles that bound rational homology circles”, preprint, 2020. [arXiv 2006.14986](#)
- [21] A. Stoimenow, “The skein polynomial of closed 3-braids”, *J. Reine Angew. Math.* **564** (2003), 167–180. [MR](#) [Zbl](#)
- [22] T. Tsukamoto, “The almost alternating diagrams of the trivial knot”, *J. Topol.* **2**:1 (2009), 77–104. [MR](#) [Zbl](#)

Received June 9, 2022.

VITALIJS BREJEVS  
SCHOOL OF MATHEMATICS AND STATISTICS  
UNIVERSITY OF GLASGOW  
GLASGOW  
UNITED KINGDOM  
[vitalijs.brejevs@glasgow.ac.uk](mailto:vitalijs.brejevs@glasgow.ac.uk)



# VANISHING THEOREMS AND ADJOINT LINEAR SYSTEMS ON NORMAL SURFACES IN POSITIVE CHARACTERISTIC

MAKOTO ENOKIZONO

We prove the Kawamata–Viehweg vanishing theorem for a large class of divisors on surfaces in positive characteristic. By using this vanishing theorem, Reider-type theorems and extension theorems of morphisms for normal surfaces are established. As an application of the extension theorems, we characterize nonsingular rational points on any plane curve over an arbitrary base field in terms of rational functions on the curve.

1. Introduction	71
2. Notations and terminology	75
3. Chain-connected divisors	76
4. Vanishing theorem on $H^1$	82
5. Adjoint linear systems for effective divisors	93
6. Extension theorems in positive characteristic	100
7. Applications to plane curves	103
Appendix. Mumford’s intersection form	104
Acknowledgement	107
References	107

## 1. Introduction

This paper is a continuation of [Enokizono 2020]. The purpose of this paper is to establish the vanishing theorem and the criterion for spannedness of adjoint linear systems  $|K_X + D|$  for *positive* divisors  $D$  on normal surfaces  $X$  in positive characteristic.

**Vanishing theorems.** Kodaira-type vanishing theorems are fundamental tools in algebraic geometry. Unfortunately, Kodaira’s vanishing theorem fails in positive characteristic [Raynaud 1978]. In the case of surfaces, it is known that Kodaira’s vanishing, or more generally, the Kawamata–Viehweg vanishing for  $\mathbb{Z}$ -divisors, holds except for quasielliptic surfaces with Kodaira dimension 1 and surfaces of general type [Shepherd-Barron 1991; Terakawa 1999; Mukai 2013]. For these

MSC2020: 14C20, 14F17, 14G05.

Keywords: vanishing theorem, adjoint linear system, extension theorem, plane curve.

exceptional surfaces, Kodaira’s vanishing also holds under some positive condition for divisors  $D$  (e.g., the self-intersection number  $D^2$  is large to some extent) [Fujita 1983; Shepherd-Barron 1991; Terakawa 1999; Di Cerbo and Fanelli 2015; Zhang 2021]. However for the Kawamata–Viehweg vanishing for  $\mathbb{Q}$ -divisors, there exist counterexamples even for smooth rational surfaces [Cascini and Tanaka 2018; Bernasconi 2021]. Under some liftability conditions, it is known that the Kawamata–Viehweg vanishing holds in full generality (see [Hara 1998; Langer 2015]). But for an arbitrary surface, the only known results are the asymptotic versions of the Kawamata–Viehweg vanishing [Tanaka 2015]. One of the main result in this paper is the following vanishing theorem for surfaces in positive characteristic:

**Theorem 1.1 (Theorem 4.17).** *Let  $X$  be a normal proper surface over an algebraically closed field  $k$  of positive characteristic. Let  $D$  be a big  $\mathbb{Z}$ -positive divisor on  $X$ . If  $\dim |D| \geq \dim H^1(\mathcal{O}_X)_n$ , then  $H^i(\mathcal{O}_X(K_X + D)) = 0$  holds for any  $i > 0$ .*

Here,  $H^1(\mathcal{O}_X)_n$  denotes the nilpotent part of  $H^1(\mathcal{O}_X)$  under the Frobenius action, and a divisor  $D$  on  $X$  is said to be  $\mathbb{Z}$ -positive if  $B - D$  is not nef over  $B$  for any effective negative definite divisor  $B > 0$  on  $X$ . Typical examples of  $\mathbb{Z}$ -positive divisors are the round-ups  $D = \lceil M \rceil$  of nef  $\mathbb{Q}$ -divisors  $M$  and numerically connected divisors which are not negative definite. Theorem 1.1 is new even when  $X$  is smooth (and of general type) and  $D$  is ample.

A well-known proof of the Kawamata–Viehweg vanishing theorem is to use the covering method and reduce to the Kodaira vanishing theorem (see [Kawamata et al. 1987]). In positive characteristic, although the Kodaira vanishing theorem holds for almost all surfaces not of general type, it is difficult to apply the covering method. The reason is that the covering method reduces the vanishing of the cohomology on a given surface  $X$  to that on the total space  $Y$  of a covering  $Y \rightarrow X$ , but in many cases  $Y$  must be of general type, and so Kodaira’s vanishing cannot be applied. For this reason, we use another method to prove Theorem 1.1. The key observation to prove Theorem 1.1 is to study the connectedness of effective divisors and to prove the following lemma:

**Lemma 1.2 (Corollary 3.13).** *Let  $D > 0$  be an effective big  $\mathbb{Z}$ -positive divisor on a normal complete surface  $X$  over an algebraically closed field  $k$ . Then  $H^0(\mathcal{O}_D) \cong k$ .*

For the higher-dimensional case, we will prove the following vanishing theorem on  $H^1$ :

**Theorem 1.3 (Theorem 4.20).** *Let  $X$  be a normal projective variety of dimension greater than 1 over an algebraically closed field  $k$ . Let  $D$  be a divisor on  $X$  such that  $D = \lceil M \rceil$  for some nef  $\mathbb{R}$ -divisor  $M$  on  $X$  with  $\kappa(D) \geq 2$  or  $v(M) \geq 2$ . If  $\text{char } k > 0$ , we further assume that  $\dim |D| \geq \dim H^1(\mathcal{O}_X)_n$ . Then  $H^1(X, \mathcal{O}_X(-D)) = 0$ .*

**Adjoint linear systems.** For adjoint linear systems  $|K_X + D|$  on varieties  $X$ , it is expected that the “positivity” of the divisor  $D$  implies the “spannedness” of the linear system  $|K_X + D|$  (Fujita’s conjecture is a typical statement). For smooth surfaces  $X$  in characteristic 0, Reider’s theorem [1988] roughly says that if the adjoint linear system  $|K_X + D|$  for a nef and big divisor  $D$  has a base point, there exists a curve  $B$  on  $X$  obstructing the basepoint-freeness such that  $D$  and  $B$  satisfy some numerical conditions. Reider’s method enables us to give various applications of adjoint linear systems, especially, the affirmative answer to Fujita’s conjecture for surfaces in characteristic 0. On the other hand, although Shepherd-Barron and others [Shepherd-Barron 1991; Terakawa 1999; Moriwaki 1993; Di Cerbo and Fanelli 2015] studied adjoint linear systems on smooth surfaces in positive characteristic by using Reider’s method based on some Bogomolov-type inequalities, there exist counterexamples to Fujita’s conjecture for surfaces in positive characteristic [Gu et al. 2022]. In this paper, as applications of Theorem 1.1 and other vanishing results (Corollary 4.9, Propositions 4.11 and 4.12), we give some results for adjoint linear systems on not necessarily smooth surfaces in positive characteristic. Here, we state immediate corollaries of the main result, Theorem 5.2:

**Corollary 1.4 (Corollary 5.8).** *Let  $X$  be a normal complete surface over an algebraically closed field  $k$ . When  $\text{char } k > 0$ , we further assume that the Frobenius map on  $H^1(\mathcal{O}_X)$  is injective. Let  $x \in X$  be at most a rational singularity. Let  $L$  be a divisor on  $X$  which is Cartier at  $x$ . We assume that there exists an integral curve  $D \in |L - K_X|$  passing through  $x$  such that  $(X, x)$  or  $(D, x)$  is singular and  $D$  is analytically irreducible at  $x$  when  $\text{char } k > 0$ . Then  $x$  is not a base point of  $|L|$ .*

**Corollary 1.5 (Corollary 5.10).** *Let  $X$  be a normal proper surface over an algebraically closed field  $k$  of positive characteristic. Assume that the geometric genus of any singular point of  $X$  is less than 4. Let  $D$  be a nef divisor on  $X$  such that  $K_X + D$  is Cartier. Then  $|K_X + D|$  is base point free if the following hold:*

- (i)  $D^2 > 4$ ,
- (ii)  $DB \geq 2$  for any curve  $B$  on  $X$ , and
- (iii)  $\dim |D| \geq \dim H^1(\mathcal{O}_X)_n + 3$ .

The following is a partial answer to Fujita’s conjecture for surfaces in positive characteristic:

**Corollary 1.6 (Corollary 5.13).** *Let  $X$  be a projective surface with at most rational double points over an algebraically closed field  $k$  of positive characteristic. Let  $H$  be an ample divisor on  $X$ . Then  $|K_X + mH|$  is base point free for any  $m \geq 3$  with  $\dim |mH| \geq \dim H^1(\mathcal{O}_X)_n + 3$  and is very ample for any  $m \geq 4$  with  $\dim |mH| \geq \dim H^1(\mathcal{O}_X)_n + 6$ .*

For other corollaries (e.g., for the pluri-(anti)canonical systems on normal surfaces), see [Section 5](#).

**Extension theorems.** In this paper, *extension theorem* means the result of the extendability of morphisms defined on a divisor to the whole variety. For the surface case, the extension theorem goes back to the results of Saint-Donat [1974] and Reid [1976] for  $K3$  surfaces. After that, Serrano [1987] and Paoletti [1995] proved extension theorems for integral curves on smooth surfaces. These results were generalized in [Enokizono 2020] for possibly reducible or nonreduced curves on normal surfaces in characteristic 0. In this paper, as an application of the Reider-type theorem ([Theorem 5.5](#)), we give a positive characteristic analog of this extension theorem.

**Theorem 1.7 (Theorem 6.1).** *Let  $D > 0$  be an effective divisor on a normal complete surface  $X$  over an algebraically closed field  $k$  of positive characteristic, and assume that any prime component  $D_i$  of  $D$  has positive self-intersection number. Let  $\varphi: D \rightarrow \mathbb{P}^1$  be a finite separable morphism of degree  $d$ . If  $D^2 > \mu(q_X, d)$  and  $\dim |D| \geq 3d + \dim H^1(\mathcal{O}_X)_n$ , then there exists a morphism  $\psi: X \rightarrow \mathbb{P}^1$  such that  $\psi|_D = \varphi$ .*

For the definition of  $\mu(q_X, d)$ , see [Definition 5.4](#) (e.g.,  $\mu(q_X, d) \leq (d + 1)^2$  holds when  $X$  is smooth). Some variants of extension theorems are established in [Section 6](#).

As an application of the extension theorems, we give a characterization of nonsingular  $k$ -rational points of plane curves  $D \subseteq \mathbb{P}^2$  over any base field  $k$  in terms of rational functions on  $D$ , which is a natural generalization of the classical result in [Namba 1979] that the gonality of smooth complex plane curves of degree  $m$  is equal to  $m - 1$ .

**Theorem 1.8 (Theorem 7.2).** *Let  $D \subseteq \mathbb{P}^2$  be a plane curve of degree  $m \geq 3$  over an arbitrary base field  $k$ . Then there is a one-to-one correspondence between:*

- (i) *the set of nonsingular  $k$ -rational points of  $D$  which are not strange, and*
- (ii) *the set of finite separable morphisms  $D \rightarrow \mathbb{P}^1$  of degree  $m - 1$  up to automorphisms of  $\mathbb{P}^1$ .*

*Moreover, any finite separable morphism  $D \rightarrow \mathbb{P}^1$  has degree greater than or equal to  $m - 1$ .*

**Structure of the paper.** The present paper is organized as follows. In [Section 2](#), we fix some notations and terminology used in this paper. In [Section 3](#), we discuss chain-connected divisors, which play a central role in this paper. The key result in this section is the chain-connectedness of big  $\mathbb{Z}$ -positive divisors ([Proposition 3.11](#)). This is used to prove the main vanishing theorem ([Theorem 4.17](#)).

In the first half of [Section 4](#), we study the kernel  $\alpha(X, D)$  of the restriction map  $H^1(\mathcal{O}_X) \rightarrow H^1(\mathcal{O}_D)$  for divisors  $D$  on  $X$  following the arguments in [\[Mumford 1967\]](#), [\[Francia 1991\]](#) and [\[Barth et al. 2004\]](#). The rest of [Section 4](#) is devoted to the vanishing theorem on surfaces in positive characteristic and its generalization. The essential idea is the combination of Fujita’s [\[1983, Theorem 7.4\]](#) and Mumford’s [\[1967, p. 99\]](#) arguments and the chain-connectedness of big  $\mathbb{Z}$ -positive divisors. In [Section 5](#), we study adjoint linear systems on normal surfaces in positive characteristic as an application of the vanishing theorems obtained in [Section 4](#). The proof of the main result ([Theorem 5.2](#)) is almost similar to that of [\[Enokizono 2020, Theorem 5.2\]](#). The only difference is the use of the chain-connected component decomposition (see [\[Konno 2010, Corollary 1.7\]](#)) instead of the integral Zariski decomposition [\[Enokizono 2020, Theorem 3.5\]](#). In [Section 6](#), we give extension theorems for normal surfaces in positive characteristic by using the Reider-type theorem ([Theorem 5.5](#)) obtained in [Section 5](#). As an application of the extension theorems, nonsingular  $k$ -rational points of any plane curve  $D \subseteq \mathbb{P}^2$  over an arbitrary base field  $k$  are characterized in terms of rational functions on  $D$  in [Section 7](#). In the [Appendix](#), Mumford’s intersection form on a normal projective variety is formulated.

## 2. Notations and terminology

In this paper, we mainly work on the category of schemes over a field  $k$ . (Some results also hold on the category of complex analytic spaces).

- A *divisor* means a Weil divisor (not necessarily  $\mathbb{Q}$ -Cartier).
- For a divisor  $D$  on a normal variety  $X$ , we denote by  $\mathcal{O}_X(D)$  the divisorial sheaf on  $X$  with respect to  $D$ . For an effective divisor  $D$  on  $X$ , we sometimes regard it as a subscheme of pure codimension 1 defined by the ideal sheaf  $\mathcal{O}_X(-D) \subseteq \mathcal{O}_X$ .
- For a  $\mathbb{Q}$ -divisor (respectively, nef  $\mathbb{R}$ -divisor)  $D$  on a normal proper variety  $X$ , we denote by  $\kappa(D)$  (respectively,  $\nu(D)$ ) the *Iitaka dimension* (respectively, *numerical dimension*) of  $D$  (for details, see [\[Kawamata et al. 1987, Chapter 6\]](#) or [\[Fujino 2017, Section 2.4\]](#)).
- For a normal projective variety  $X$  of dimension  $\geq 2$  over an infinite field  $k$  and a divisor  $D$  on  $X$ , we freely use the following Bertini-type result (for details, see [\[Huybrechts and Lehn 1997, Section 1.1\]](#)): Any general hyperplane  $Y$  on  $X$  is also a normal projective variety and satisfies  $\mathcal{O}_Y(D|_Y) \cong \mathcal{O}_X(D)|_Y$ .
- For a normal proper surface  $X$ , we freely use Mumford’s intersection product

$$\mathrm{Cl}(X) \times \mathrm{Cl}(X) \rightarrow \mathbb{Q}, \quad (D, E) \mapsto DE,$$

extending the usual intersection product [\[Mumford 1961\]](#). By using this intersection form, we can extend the numerical properties of Cartier divisors on  $X$  such as nef,

pseudoeffective, big and so on to that on Weil divisors naturally (for example, see [Enokizono 2020, Appendix A]). For a higher-dimensional analog of Mumford's intersection form, see the [Appendix](#).

- For a scheme  $X$  over a field of characteristic  $p > 0$ , let us denote by  $F$  the absolute Frobenius morphism on  $X$  and the induced homomorphism on the cohomology  $H^m(\mathcal{O}_X)$ . Note that  $F: H^m(\mathcal{O}_X) \rightarrow H^m(\mathcal{O}_X)$  is  $p$ -linear, that is,  $F(av) = a^p F(v)$  for  $a \in k$  and  $v \in H^m(\mathcal{O}_X)$ .
- For a  $p$ -linear transform  $F: V \rightarrow V$  of a finite-dimensional vector space  $V$  over a field  $k$  of characteristic  $p > 0$ , we write the *semisimple part of  $V$*  (respectively, *nilpotent part of  $V$* ) by  $V_s := \text{Im } F^l$  (respectively,  $V_n := \text{Ker } F^l$ ), where  $l \gg 0$ . Then it is well known that  $V = V_s \oplus V_n$ , and there exists a  $k$ -basis  $\{e_i\}$  of  $V_s$  such that  $F(e_i) = e_i$  for each  $i$  when  $k$  is algebraically closed (for the proof, see [Chambert-Loir 1998, Exposé III, Lemma 3.3]).
- A finite surjective morphism  $f: X \rightarrow Y$  from a proper scheme  $X$  to a variety  $Y$  is called *separable* if the restriction  $f|_{X_i}$  induces a separable field extension  $(f|_{X_{i,\text{red}}})^*: K(Y) \hookrightarrow K(X_{i,\text{red}})$  between function fields for each irreducible component  $X_i$  of  $X$ .

### 3. Chain-connected divisors

**Connectedness of effective divisors.** We introduce some notions about connectivity for effective divisors on normal surfaces, which are well known for smooth surfaces. In this section,  $X$  stands for a normal proper surface over a base field  $k$  (or a normal compact analytic surface) unless otherwise stated.

**Definition 3.1** (connectedness for effective divisors). Let  $D$  be a nonzero effective divisor on  $X$ .

- (1) We say that  $D$  is *chain-connected* (respectively, *numerically connected*) if  $-A$  is not nef over  $B$ , that is,  $AC > 0$  for some curve  $C$  contained in the support of  $B$  (respectively,  $AB > 0$ ) for any effective decomposition  $D = A + B$  with  $A, B > 0$ .
- (2) Let  $m \in \mathbb{Q}$ . We say that  $D$  is  *$m$ -connected* (respectively, *strictly  $m$ -connected*) if  $AB \geq m$  (respectively,  $AB > m$ ) for any effective decomposition  $D = A + B$  with  $A, B > 0$ . Clearly, numerical connectivity is equivalent to strict 0-connectivity and implies chain-connectivity.
- (3) For a subdivisor  $0 < D_0 \leq D$ , a *connecting chain from  $D_0$  to  $D$*  is defined to be a sequence of subdivisors  $D_0 < D_1 < \dots < D_m = D$  such that  $C_i := D_i - D_{i-1}$  is prime and  $D_{i-1}C_i > 0$  for each  $i = 1, \dots, m$ . We regard  $D_0 = D$  as a connecting chain from  $D$  to  $D$  ( $m = 0$  case).

The following lemma is easy and well known:

**Lemma 3.2.** *Let  $H$  be an ample Cartier divisor on  $X$  and  $n > 1$ . Then any effective divisor  $D$  which is numerically equivalent to  $nH$  is  $(n - 1/H^2)$ -connected.*

*Proof.* Let  $D = A + B$  be a nontrivial effective decomposition. By the Hodge index theorem, we can write  $A \equiv aH + A'$  and  $B \equiv bH + B'$ , where  $a := AH/H^2$ ,  $b := BH/H^2$ ,  $A'H = 0$  and  $B'H = 0$ , with  $A'^2 \leq 0$  and  $B'^2 \leq 0$ . Note that both  $a$  and  $b$  are greater than or equal to  $1/H^2$ , since  $H$  is ample Cartier. Since  $A + B \equiv nH$ , it follows that  $a + b = n$  and  $A' + B' \equiv 0$ . Thus,

$$AB = abH^2 + A'B' = a(n - a)H^2 - A'^2 \geq \frac{1}{H^2} \left( n - \frac{1}{H^2} \right) H^2 = n - \frac{1}{H^2}. \quad \square$$

Similarly, we can prove the following (for the proof, see [Ramanujam 1972, Lemma 2] or [Kawachi and Mašek 1998, p. 242]):

**Lemma 3.3** (Ramanujam's connectedness lemma). *Let  $D$  be an effective, nef and big divisor on  $X$ . Then  $D$  is numerically connected.*

The following lemmas are due to [Konno 2010] (the proof also works on possibly singular normal surfaces):

**Lemma 3.4** [Konno 2010, Proposition 1.2]. *Let  $D > 0$  be an effective divisor on  $X$ . Then the following are equivalent:*

- (i)  $D$  is chain-connected.
- (ii) For any subdivisor  $0 < D_0 \leq D$ , there exists a connecting chain from  $D_0$  to  $D$ .
- (iii) There exist a prime component  $D_0$  of  $D$  and a connecting chain from  $D_0$  to  $D$ .

**Lemma 3.5** ([Konno 2010, Proposition 1.5 (3)]). *Let  $D > 0$  be an effective divisor on  $X$  with connected support. Then there exists the greatest chain-connected subdivisor  $0 < D_c \leq D$  such that  $\text{Supp}(D_c) = \text{Supp}(D)$  and  $-D_c$  is nef over  $D - D_c$ .*

**Definition 3.6** (chain-connected component). Let  $D > 0$  be an effective divisor on  $X$  with connected support. We say that the greatest chain-connected subdivisor  $D_c$  of  $D$ , as in Lemma 3.5, is called the *chain-connected component* of  $D$ . Similarly, for any effective divisor  $D > 0$  on  $X$ , we can take the chain-connected component for each connected component of  $D$ .

The following proposition can be proved similarly to that of [Enokizono 2020, Proposition 3.19]:

**Proposition 3.7.** *Let  $\pi : X' \rightarrow X$  be a proper birational morphism between normal complete surfaces. Then for any chain-connected divisor  $D$  on  $X$ , the round-up of the Mumford pullback  $\lceil \pi^* D \rceil$  is chain-connected.*

*Proof.* We write

$$D' := \lceil \pi^* D \rceil = \pi^* D + D_\pi,$$

where  $D_\pi$  is a  $\pi$ -exceptional  $\mathbb{Q}$ -divisor on  $X'$  with  $\lfloor D_\pi \rfloor = 0$ . Note that  $D'$  has connected support since  $D$  does. Assume that  $D'$  is not chain-connected, that is,  $D'_c < D'$ . Let  $B' := D' - D'_c$ . It follows from [Lemma 3.5](#) that  $\text{Supp}(D'_c) = \text{Supp}(D')$  and  $-D'_c$  is nef over  $B'$ . We write  $B' = \pi^*B + B_\pi$ , where  $B := \pi_*B' \geq 0$  and  $B_\pi$  is a  $\pi$ -exceptional  $\mathbb{Q}$ -divisor. Let

$$B_\pi - D_\pi = G^+ - G^-$$

be the decomposition of effective  $\pi$ -exceptional  $\mathbb{Q}$ -divisors  $G^+$  and  $G^-$  having no common components. Note that the support of  $G^+$  is contained in that of  $B'$ . First we assume that  $G^+ > 0$ . Then there exists a prime component  $C$  of  $G^+$  such that  $G^+C < 0$  since  $G^+$  is negative definite. It follows that  $C \leq B'$  and

$$-D'_cC = (B' - D')C = (\pi^*(B - D) + G^+ - G^-)C = (G^+ - G^-)C < 0,$$

which contradicts the nefness of  $-D'_c$  over  $B'$ . Hence, we have  $G^+ = 0$ . This and  $\lfloor D_\pi \rfloor = 0$  imply  $B > 0$ . Indeed, if  $B = 0$ , then  $B_\pi = B'$  is nonzero effective with integral coefficients, which contradicts  $\lfloor B_\pi \rfloor = \lfloor D_\pi - G^- \rfloor \leq 0$ . Since  $D$  is chain-connected and  $D - B = \pi_*D'_c > 0$ , there exists a prime component  $C$  of  $B$  such that  $(B - D)C < 0$ . Let  $\hat{C}$  be the proper transform of  $C$  on  $X'$ . Then it is a component of  $B'$  and

$$-D'_c\hat{C} = (B' - D')\hat{C} = (\pi^*(B - D) - G^-)\hat{C} = (B - D)C - G^-\hat{C} < 0,$$

which contradicts the nefness of  $-D'_c$  over  $B'$ . Hence, we conclude that  $D'$  is chain-connected.  $\square$

**Example 3.8.** The numerically connected version of [Proposition 3.7](#) does not hold: Let  $f: S \rightarrow \mathbb{P}^1$  be an elliptic surface having a singular fiber  $F = f^{-1}(0)$  of type  $I_1$ . Take three blow-ups

$$X' := S_3 \xrightarrow{\rho_3} S_2 \xrightarrow{\rho_2} S_1 \xrightarrow{\rho_1} S_0 := S$$

at single points  $p_i \in S_{i-1}$ , where  $p_1$  and  $p_2$ , respectively, are a general point in  $F$  and the node of  $F$  and  $p_3$  is a point in the intersection of the  $\rho_2$ -exceptional curve and the proper transform of  $F$ . Let  $C'_1$ ,  $C'_2$  and  $C'_3$ , respectively, denote the  $\rho_3$ -exceptional curve, the proper transform of the  $\rho_2$ -exceptional curve and the proper transform of  $F$  on  $X'$ . Then we have  $(C'_i)^2 = -i$  and  $C'_iC'_j = 1$  for  $i \neq j$ . Let  $\pi: X' \rightarrow X$  be the contraction of  $C'_3$  and put  $C_i := \pi_*C'_i$  for  $i = 1, 2$ . Note that  $X$  has one cyclic quotient singularity at  $\pi(C'_3)$  and  $C'_i = \pi^*C_i - \frac{1}{3}C_3$  for  $i = 1, 2$ . Thus, we have  $C_1^2 = -\frac{2}{3}$ ,  $C_2^2 = -\frac{5}{3}$  and  $C_1C_2 = \frac{4}{3}$ . Then  $D := 2C_1 + 2C_2$  is numerically connected but  $\lceil \pi^*D \rceil = 2C'_1 + 2C'_2 + 2C'_3$  is not numerically connected since  $(C'_1 + C'_2 + C'_3)^2 = 0$ .



**Lemma 3.9.** *Let  $D > 0$  be a chain-connected divisor on  $X$ . Then  $H^0(\mathcal{O}_D)$  is a field. Moreover, if  $D$  contains a prime divisor  $C$  such that  $H^0(\mathcal{O}_C) \cong H^0(\mathcal{O}_X)$ , then we have  $H^0(\mathcal{O}_D) \cong H^0(\mathcal{O}_X)$ .*

*Proof.* First, we show the claim when  $X$  is regular. By [Lemma 3.4](#), we can take a connecting chain  $C =: D_0 < D_1 < \dots < D_m := D$  for any prime component  $C$  of  $D$ . Putting  $C_i := D_i - D_{i-1}$ , we have  $D_{i-1}C_i > 0$  for each  $i$ . By the exact sequence

$$0 \rightarrow \mathcal{O}_{C_i}(-D_{i-1}) \rightarrow \mathcal{O}_{D_i} \rightarrow \mathcal{O}_{D_{i-1}} \rightarrow 0$$

and  $H^0(\mathcal{O}_{C_i}(-D_{i-1})) = 0$  for each  $i$ , we have a chain of injections

$$H^0(\mathcal{O}_X) \hookrightarrow H^0(\mathcal{O}_D) \hookrightarrow H^0(\mathcal{O}_{D_{m-1}}) \hookrightarrow \dots \hookrightarrow H^0(\mathcal{O}_{D_0}).$$

Thus,  $H^0(\mathcal{O}_D)$  is a subfield of  $H^0(\mathcal{O}_C)$ . If, moreover, we assume  $H^0(\mathcal{O}_X) \cong H^0(\mathcal{O}_C)$ , then all the injections above are isomorphisms.

For a general  $X$ , we take a resolution  $\pi : X' \rightarrow X$  and put  $D' := \lceil \pi^* D \rceil$ . By [Proposition 3.7](#),  $D'$  is also chain-connected. We note that there are natural injections

$$H^0(\mathcal{O}_X) \hookrightarrow H^0(\mathcal{O}_D) \hookrightarrow H^0(\mathcal{O}_{D'}).$$

Thus,  $H^0(\mathcal{O}_D)$  is a subfield of  $H^0(\mathcal{O}_{D'})$ . If  $D$  contains a prime divisor  $C$  with  $H^0(\mathcal{O}_X) \cong H^0(\mathcal{O}_C)$ , then the proper transform  $\hat{C}$  of  $C$  satisfies  $H^0(\mathcal{O}_{X'}) \cong H^0(\mathcal{O}_{\hat{C}})$  since  $H^0(\mathcal{O}_X) \cong H^0(\mathcal{O}_{X'})$  and  $H^0(\mathcal{O}_C) \cong H^0(\mathcal{O}_{\hat{C}})$ . From the assertion for regular surfaces, we obtain  $H^0(\mathcal{O}_{D'}) \cong H^0(\mathcal{O}_{X'})$ . Hence,  $H^0(\mathcal{O}_X) \cong H^0(\mathcal{O}_D)$ .  $\square$

**Chain-connected vs.  $\mathbb{Z}$ -positive.** Let us recall the notion of  $\mathbb{Z}$ -positive divisors on normal surfaces introduced in [\[Enokizono 2020\]](#).

**Definition 3.10** ( $\mathbb{Z}$ -positive divisors). A divisor  $D$  on a normal complete surface  $X$  is called  $\mathbb{Z}$ -positive if  $B - D$  is not nef over  $B$  (i.e.,  $BC < DC$  holds for some irreducible component  $C$  of  $B$ ) for any effective negative definite divisor  $B > 0$  on  $X$ .

Typical examples of  $\mathbb{Z}$ -positive divisors are chain-connected divisors which are not negative definite and the round-ups of nef  $\mathbb{R}$ -divisors (see [\[Enokizono 2020, Proposition 3.16\]](#)). In this subsection, we prove the following result, which is an analog of [Lemma 3.3](#):

**Proposition 3.11.** *Any effective big  $\mathbb{Z}$ -positive divisor is chain-connected.*

*Proof.* Let  $D > 0$  be an effective big  $\mathbb{Z}$ -positive divisor on  $X$ . First we note that the support of  $D$  is connected since  $D$  is obtained by a connecting chain from the round-up  $\lceil P(D) \rceil$  of the positive part  $P(D)$  in the Zariski decomposition of  $D$  (see [\[Enokizono 2020, Proposition 3.16\]](#)) and the support of  $P(D)$  is connected by [Lemma 3.3](#). Let  $D_c$  be the chain-connected component of  $D$  and suppose that  $D - D_c \neq 0$ . Let us take its Zariski decomposition

$$D - D_c = P + N.$$

If  $P = 0$ , then  $D - D_c$  is negative definite, which contradicts the  $\mathbb{Z}$ -positivity of  $D$ . Thus, we have  $P \neq 0$ . Since  $D_c P \leq 0$ ,  $\text{Supp}(D_c) = \text{Supp}(D)$  and  $P$  is nef, it follows that  $P$  is numerically trivial over  $D$ . In particular, we have  $P^2 = 0$ . Since  $\text{Supp}(D)$  is connected and  $P \neq 0$ , the support of  $P$  coincides with that of  $D$ . Thus,  $D$  is negative semidefinite. On the other hand, by the assumption that  $D$  is big, we have  $P(D)^2 > 0$ , which contradicts the negative semidefiniteness of  $D$ . Hence, we conclude that  $D = D_c$ .  $\square$

**Remark 3.12.** (1) Conversely, any big chain-connected divisor is  $\mathbb{Z}$ -positive since for any effective divisor  $D > 0$  with connected support,  $D$  is big if and only if  $D$  is not negative semidefinite (see [Enokizono 2020, Lemma A.12]). Thus, for any effective big divisor  $D$  with connected support, its  $\mathbb{Z}$ -positive part  $P_{\mathbb{Z}}$  in the integral Zariski decomposition [Enokizono 2020, Theorem 3.5] coincides with the chain-connected component  $D_c$ .

(2) In general, effective  $\mathbb{Z}$ -positive divisors are not chain-connected even if  $D$  has connected support. For example, a multiple  $nF$  of a fiber  $F = f^{-1}(t)$  of a fibration  $f: X \rightarrow B$  over a curve  $B$  is  $\mathbb{Z}$ -positive, but not chain-connected for  $n \geq 2$ .

Combining Proposition 3.11 with Lemma 3.9, we obtain the following:

**Corollary 3.13.** *Let  $D$  be an effective big  $\mathbb{Z}$ -positive divisor on a normal complete surface. Then  $H^0(\mathcal{O}_D)$  is a field.*

**Base change property.** In this subsection, let  $X$  be a normal proper geometrically connected surface over a field  $k$  and  $k \subseteq k'$  a separable field extension. Then  $X_{k'} := X \times_k k'$  is also a normal surface with  $H^0(\mathcal{O}_{X_{k'}}) \cong k'$ .

**Lemma 3.14.** *Let  $D$  be a pseudoeffective  $\mathbb{Z}$ -positive divisor on  $X$ . Then  $D_{k'}$  is also a pseudoeffective  $\mathbb{Z}$ -positive divisor on  $X_{k'}$ .*

*Proof.* Let  $D = P + N$  be the Zariski decomposition of  $D$ . Then there exists a connecting chain

$$D_0 := \lceil P \rceil < D_1 < \cdots < D_N := D$$

such that  $C_i := D_i - D_{i-1}$  is prime and satisfies  $D_{i-1}C_i > 0$  for each  $i$  from [Enokizono 2020, Proposition 3.16]. On the other hand, one can see that  $D_{k'} = P_{k'} + N_{k'}$  is also the Zariski decomposition of  $D_{k'}$ . (Indeed,  $P_{k'}$  is also nef and  $P_{k'}N_{k'} = PN = 0$ . Thus, the Hodge index theorem implies that  $N_{k'}$  is negative definite if  $D$  is big. When  $D$  is not big, then by the pseudoeffectivity of  $D$ , this can be written by the limit of big divisors in the numerical class group of  $X$ . Thus, the claim holds by the continuity of the Zariski decomposition.) Since the extension  $k'/k$  is separable, it follows that

$$\lfloor N_{k'} \rfloor = \lfloor N \rfloor_{k'} = \sum_{i=1}^N C_{i,k'},$$

and  $C_{i,k'}$  is reduced. Let  $C_{i,k'} = \sum_{j=1}^{l(i)} C'_{i,j}$  be the irreducible decomposition. Since  $D_{i-1,k'} C'_{i,j} > 0$  for any  $i$  and  $j$ , we can construct a connecting chain from  $\lceil P_{k'} \rceil$  to  $D_{k'}$ , whence  $D_{k'}$  is  $\mathbb{Z}$ -positive from [Enokizono 2020, Proposition 3.16].  $\square$

Combining Lemma 3.14 with Proposition 3.11, we obtain the following:

**Corollary 3.15.** *Let  $D > 0$  be a chain-connected divisor on  $X$  which is not negative semidefinite. Then  $D_{k'}$  is also chain-connected.*

**Remark 3.16.** In general, chain-connectivity is not preserved by a separable base change. Indeed, let  $X$  be a surface obtained by the blow-up of  $\mathbb{P}^2$  at a closed point  $x$  such that the extension  $k(x)/k$  is nontrivial and separable. Then the exceptional divisor  $E_x$  on  $X$  is chain-connected, but  $E_{x,k(x)}$  is a disjoint union of the exceptional curves on  $X_{k(x)}$ .

**Corollary 3.17.** *Let  $D$  be an effective big  $\mathbb{Z}$ -positive divisor on  $X$ . Then  $H^0(\mathcal{O}_D)/k$  is a purely inseparable field extension.*

*Proof.* Let  $k'$  be the separable closure of  $k$  in the field  $H^0(\mathcal{O}_D)$  and assume  $k \neq k'$ . Then  $H^0(\mathcal{O}_{D_{k'}}) \cong H^0(\mathcal{O}_D) \otimes_k k'$  is not a field, which contradicts Lemma 3.14 and Corollary 3.13.  $\square$

**Chain-connected divisors on projective varieties.** We introduce chain-connected divisors on higher-dimensional varieties which are used later.

**Definition 3.18** (chain-connected divisors). Let  $X$  be a normal projective variety of dimension  $n \geq 3$  over an algebraically closed field  $k$  and  $H$  an ample divisor on  $X$ . A divisor  $D$  on  $X$  is called  *$H$ -nef* (respectively,  *$H$ -nef over an effective divisor  $B$* ) if  $H^{n-2}DC \geq 0$  for any prime divisor  $C$  (respectively, any prime component  $C \leq B$ ) on  $X$ , where we use Mumford's intersection form for  $n - 2$  Cartier divisors and two Weil divisors on  $X$  (see the Appendix). An effective divisor  $D > 0$  on  $X$  is said to be *chain-connected with respect to  $H$*  if  $-A$  is not  $H$ -nef over  $B$  for any nontrivial effective decomposition  $D = A + B$ . We simply call  $D$  *chain-connected* if it is chain-connected with respect to some ample divisor  $H$  on  $X$ .

**Example 3.19.** The following effective divisors  $D$  are typical examples of chain-connected divisors:

- (i)  $D$  is reduced and connected.
- (ii)  $D = \lceil M \rceil$ , where  $M$  is an  $\mathbb{R}$ -divisor which is nef in codimension 1 and satisfies  $\nu(M) \geq 2$  or  $\kappa(D) \geq 2$ .

Here, we say that an  $\mathbb{R}$ -Cartier  $\mathbb{R}$ -divisor  $D$  on a normal complete variety  $X$  is *nef in codimension 1* if there exists a closed subset  $Z$  of  $X$  with codimension  $\geq 2$  such that  $DC \geq 0$  holds for any integral curve  $C$  on  $X$  not contained in  $Z$  (which is also called numerically semipositive in codimension one in [Fujita 1983]). A Weil  $\mathbb{R}$ -divisor  $D$

on  $X$  is called *nef* (respectively, *nef in codimension 1*) if there exist an alteration  $\pi : X' \rightarrow X$  and a nef (respectively, nef in codimension 1)  $\mathbb{R}$ -Cartier  $\mathbb{R}$ -divisor  $D'$  on  $X'$  such that  $D = \pi_* D'$ . By using Mumford's intersection form, the property  $\nu(D) \geq 2$  makes sense as  $H^{\dim X - 2} D^2 > 0$  for some ample divisor  $H$  on  $X$ . Note that for  $\dim X = 2$ , condition (ii) is equivalent to  $D$  being the round-up of a nef and big  $\mathbb{R}$ -divisor  $M$ . Therefore, the proof for the chain-connectivity of the divisor  $D$  in (ii) is reduced to the surface case by cutting with general hyperplanes in  $|mH|$ , with  $m \gg 0$ , and this is due to [Proposition 3.11](#) and [\[Enokizono 2020, Corollary 3.18\]](#).

**Proposition 3.20.** *Let  $X$  be a normal projective variety over an algebraically closed field  $k$ . Let  $D$  be a chain-connected divisor on  $X$ . Then  $H^0(\mathcal{O}_D) \cong k$  holds.*

*Proof.* We show the claim by induction on  $n = \dim X$ . The  $n = 2$  case is due to [Lemma 3.9](#). We take a general hyperplane  $Y \in |mH|$  and consider the exact sequence

$$0 \rightarrow \mathcal{O}_D(-Y|_D) \rightarrow \mathcal{O}_D \rightarrow \mathcal{O}_{Y \cap D} \rightarrow 0.$$

Since  $H^0(\mathcal{O}_D(-Y|_D)) = 0$ , we have an injection  $H^0(\mathcal{O}_D) \hookrightarrow H^0(\mathcal{O}_{Y \cap D})$ . Since  $D$  is chain-connected with respect to  $H$ , the restriction  $D|_Y$  on  $Y$  is also chain-connected with respect to  $H|_Y$ . Then we have  $H^0(\mathcal{O}_{Y \cap D}) \cong k$  by the inductive hypothesis, whence  $H^0(\mathcal{O}_D) \cong k$  holds.  $\square$

Similarly, one can show the following:

**Proposition 3.21.** *Let  $X$  be a normal projective geometrically connected variety over a field  $k$ . Let  $D = \lceil M \rceil$  be an effective divisor as in [Example 3.19 \(ii\)](#). Then  $H^0(\mathcal{O}_D)/k$  is a purely inseparable field extension.*

*Proof.* Note that the condition of divisors in [Example 3.19 \(ii\)](#) is preserved by any separable base change, so we may assume that  $k$  is infinite. By the hyperplane cutting argument, as in the proof of [Proposition 3.20](#), we conclude that  $H^0(\mathcal{O}_D)$  is a field. The claim follows from the same argument in the proof of [Corollary 3.17](#).  $\square$

#### 4. Vanishing theorem on $H^1$

In this section, we prove vanishing theorems of Ramanujam-, Kawamata–Viehweg- and Miyaoka-type for normal complete surfaces and normal projective varieties.

**Picard schemes and  $\alpha(X, D)$ .** We start with an elementary lemma, which is well known to experts.

**Lemma 4.1.** *Let  $X$  be a proper scheme over an algebraically closed field  $k$  of characteristic  $p > 0$  with  $H^0(\mathcal{O}_X) \cong k$ . Then the following are equivalent:*

- (1) *The Frobenius map on  $H^1(\mathcal{O}_X)$  is injective.*
- (2)  *$H^1(X_{\text{fppf}}, \alpha_{p,X}) = 0$ , that is, all  $\alpha_p$ -torsors over  $X$  are trivial.*

(3) The Picard scheme  $\text{Pic}_{X/k}$  does not contain  $\alpha_p$ .

(4) Any infinitesimal subgroup scheme of  $\text{Pic}_{X/k}^\circ$  is linearly reductive, that is, of the form  $\prod \mu_{p^{n_i}}$ .

*Proof.* The equivalence of (i) and (ii) follows from the fact that

$$H^1(X_{\text{fppf}}, \alpha_{p,X}) \cong \{\eta \in H^1(\mathcal{O}_X) \mid F(\eta) = 0\},$$

which is obtained by the exact sequence

$$0 \rightarrow \alpha_p \rightarrow \mathbb{G}_a \xrightarrow{F} \mathbb{G}_a^{(p)} \rightarrow 0$$

of commutative group schemes over  $k$ , where  $F$  is the relative Frobenius map. The equivalence of (ii) and (iii) follows from [Raynaud 1970, Proposition (6.2.1)] with  $T = \text{Spec } k$  and  $M = \alpha_p$ . Indeed, there is a natural isomorphism

$$H^1(X_{\text{fppf}}, \alpha_{p,X}) \cong \text{Hom}_{\text{GSch}/k}(\alpha_p, \text{Pic}_{X/k})$$

as abelian groups. For the equivalence of (iii) and (iv), it suffices to show that for any  $m \geq 1$ , the  $m$ -th Frobenius kernel  $\text{Pic}_{X/k}[F^m]$  does not contain  $\alpha_p$  if and only if it is linearly reductive. This holds true for any infinitesimal group scheme by [Liedtke et al. 2021, Lemma 2.3].  $\square$

**Definition 4.2.** Let  $X$  and  $D$  be proper schemes over a field  $k$  and  $\tau : D \rightarrow X$  a morphism. Then we denote by  $\alpha(X, D)$  the kernel of  $\tau^* : H^1(\mathcal{O}_X) \rightarrow H^1(\mathcal{O}_D)$ . It can be identified with the Lie algebra of the kernel of the homomorphism  $\tau^* : \text{Pic}_{X/k} \rightarrow \text{Pic}_{D/k}$  of Picard schemes defined by the pullback of line bundles (see [Bosch et al. 1990, p. 231, Theorem 1]).

Let  $\phi : E \rightarrow D$  and  $\tau : D \rightarrow X$  be two morphisms of proper schemes over a field  $k$ . In this subsection, we are going to study the relations of  $\alpha(X, D)$  and  $\alpha(X, E)$ , which will be used in Section 5. Let  $\phi^* : \text{Pic}_{D/k}^\circ \rightarrow \text{Pic}_{E/k}^\circ$  and  $\tau^* : \text{Pic}_{X/k}^\circ \rightarrow \text{Pic}_{D/k}^\circ$  be the corresponding homomorphisms of Picard schemes.

**Lemma 4.3.** *Let  $\phi : E \rightarrow D$  and  $\tau : D \rightarrow X$  be morphisms of proper schemes over a field  $k$  and assume one of the following:*

- (i)  $\text{char } k = 0$ ,  $X$  is normal and  $\text{Ker}(\phi^*)$  is affine, or
- (ii)  $\text{char } k > 0$ ,  $H^0(\mathcal{O}_X) \cong k$ , the Frobenius map on  $H^1(\mathcal{O}_X)$  is injective and  $\text{Ker}(\phi^*)$  is unipotent.

Then  $\alpha(X, D) = \alpha(X, E)$  holds.

*Proof.* It suffices to show that  $\text{Ker}(\tau^*)^\circ = \text{Ker}(\phi^* \circ \tau^*)^\circ$ . Taking the base change to an algebraic closure  $\bar{k}$  of  $k$ , we may assume that  $k$  is algebraically closed. Let us write  $Q := \text{Im}(\tau^*|_{\text{Ker}(\phi^* \circ \tau^*)^\circ})$  and consider the exact sequence

$$1 \rightarrow \text{Ker}(\tau^*)^\circ \rightarrow \text{Ker}(\phi^* \circ \tau^*)^\circ \rightarrow Q \rightarrow 1.$$

First we assume condition (i). Then  $\text{Pic}_{X/k}^\circ$  is proper over  $k$  since  $X$  is normal [Grothendieck 1962, Exposé 236, Théorème 2.1 (ii)]. Thus,  $\text{Ker}(\phi^* \circ \tau^*)^\circ$  and  $Q := \text{Im}(\tau^*|_{\text{Ker}(\phi^* \circ \tau^*)^\circ})$  are also proper over  $k$ . On the other hand, since  $\text{Ker}(\phi^*)$  is affine, so is  $Q$ . Thus, we conclude that  $Q$  is infinitesimal, whence  $Q$  is trivial due to Cartier's theorem.

We assume condition (ii). It suffices to show that  $Q[F]$  is trivial. By Lemma 4.1, the group scheme  $\text{Pic}_{X/k}[F]$  is linearly reductive. Hence,  $\text{Ker}(\phi^* \circ \tau^*)[F]$  and  $Q[F]$  are also linearly reductive since the linear reductivity is preserved by taking subgroup schemes and quotient group schemes. On the other hand,  $Q[F]$  is unipotent since  $\text{Ker}(\phi^*)$  is. Thus,  $Q[F]$  is trivial.  $\square$

Let us recall the structure of the generalized Jacobian  $\text{Pic}_{C/k}^\circ$  of a proper curve  $C$ . The following combinatorial data is useful in counting the rank of maximal tori in  $\text{Pic}_{C/k}^\circ$ :

**Definition 4.4.** Let  $C$  be a proper curve (i.e., purely 1-dimensional proper scheme) over an algebraically closed field  $k$ . Then the *extended dual graph*  $\Gamma(C)$  of  $C$  is defined as follows: The vertex set of  $\Gamma(C)$  is the union of the integral subcurves  $\{C_i\}_i$  in  $C$  and the singularities  $\{x_\lambda\}_\lambda$  of the reduced scheme  $C_{\text{red}}$  of  $C$ . For each singular point  $x_\lambda$  of  $C_{\text{red}}$ , we denote by  $B_1, \dots, B_m$  all the local analytic branches of  $C_{\text{red}}$  (that is, the minimal primes of the complete local ring  $\hat{\mathcal{O}}_{C_{\text{red}}, x_\lambda}$ ). For each  $B_j$ , let  $C_{i(j)}$  denote the corresponding integral curve in  $C$ . Then the edges of  $\Gamma(C)$  are defined by connecting  $x_\lambda$  and  $C_{i(j)}$  for each branch  $B_j$ .

For a proper curve  $C$  over an arbitrary field  $k$ , we define the extended dual graph of  $C$  by that of  $C_{\bar{k}} = C \times_k \bar{k}$ , where  $\bar{k}$  is an algebraic closure of  $k$ .

**Proposition 4.5** [Bosch et al. 1990, Section 9.2, Proposition 10]. *Let  $C$  be a proper curve over an algebraically closed field  $k$ . Then the rank of maximal tori of  $\text{Pic}_{C/k}^\circ$  is the first Betti number  $b_1(\Gamma(C))$  of the extended dual graph of  $C$ .*

*Proof.* We may assume that  $C$  is connected. Let  $\tilde{C}$  denote the normalization of the reduced scheme  $C_{\text{red}}$  of  $C$ . Then the natural map  $\pi: \tilde{C} \rightarrow C$  can be decomposed into

$$\tilde{C} \rightarrow C' \rightarrow C_{\text{red}} \rightarrow C,$$

as in the argument in [Bosch et al. 1990, Section 9.2], where the intermediate curve  $C'$  is canonically determined as the highest birational model of  $C_{\text{red}}$  which is homeomorphic to  $C_{\text{red}}$ . Since  $\Gamma(C) = \Gamma(C_{\text{red}}) = \Gamma(C')$  and the kernel of  $\text{Pic}_{C/k}^\circ \rightarrow \text{Pic}_{C'/k}^\circ$  is unipotent by Propositions 5 and 9 in [Bosch et al. 1990, Section 9.2], we may assume  $C = C'$ . Let  $x_\lambda$ , where  $\lambda = 1, \dots, N$ , denote the singular points of  $C$ , and for each  $\lambda$ , let  $\tilde{x}_{\lambda, \mu}$ , where  $\mu = 1, \dots, n_\lambda$ , denote the points of  $\tilde{C}$  lying over  $x_\lambda$ . Let  $C_i$ , where  $i = 1, \dots, r$ , denote the integral components of  $C$ .

Taking the cohomology of the exact sequence

$$1 \rightarrow \mathcal{O}_C^* \rightarrow \pi_* \mathcal{O}_{\tilde{C}}^* \rightarrow \mathcal{T} \rightarrow 1,$$

we obtain a long exact sequence

$$1 \rightarrow k^* \rightarrow \prod_{i=1}^r k^* \rightarrow \prod_{\lambda=1}^N \left( \prod_{\mu=1}^{n_\lambda} k(\tilde{x}_{\lambda,\mu})^* \right) / k(x_\lambda)^* \rightarrow \text{Pic}(C) \rightarrow \text{Pic}(\tilde{C}) \rightarrow 1,$$

where the cokernel  $\mathcal{T}$  is a torsion sheaf supported at the singular points  $x_\lambda$ . Then the kernel of  $\pi^*: \text{Pic}_{C/k} \rightarrow \text{Pic}_{\tilde{C}/k}$  is a torus of rank  $\sum_{\lambda=1}^N (n_\lambda - 1) - r + 1$ . On the other hand, the number of vertices and edges of  $\Gamma(C)$  are  $r + N$  and  $\sum_{\lambda=1}^N n_\lambda$ , respectively. Thus, the topological Euler number of the graph is

$$\chi_{\text{top}}(\Gamma(C)) = r + N - \sum_{\lambda=1}^N n_\lambda,$$

and then the first Betti number is

$$b_1(\Gamma(C)) = 1 - \chi_{\text{top}}(\Gamma(C)) = \sum_{\lambda=1}^N (n_\lambda - 1) - r + 1,$$

which completes the proof.  $\square$

**Lemma 4.6.** *Let  $\phi: E \rightarrow D$  be a morphism between proper schemes over a field  $k$ . Then the kernel of  $\phi^*: \text{Pic}_{D/k}^\circ \rightarrow \text{Pic}_{E/k}^\circ$  is unipotent if one of the following holds:*

- (i) *The canonical immersion  $D_{\text{red}} \hookrightarrow D$  factors through  $\phi$ .*
- (ii)  *$D$  is a curve and there exists a birational morphism  $\hat{D} \rightarrow D_{\text{red}}$  with  $b_1(\Gamma(D)) = b_1(\Gamma(\hat{D}))$  such that the composition  $\hat{D} \rightarrow D_{\text{red}} \hookrightarrow D$  factors through  $\phi$ .*

*Proof.* In order to show the assertion for (i), we may assume that  $E = D_{\text{red}}$ . By taking a filtration of first-order thickenings  $D_{\text{red}} \hookrightarrow D_1 \hookrightarrow \dots \hookrightarrow D_N = D$ , we further assume that  $E \hookrightarrow D$  is a first-order thickening. Then one can show the assertion easily by taking the cohomology of the exact sequence

$$0 \rightarrow \mathcal{I}_{E/D} \rightarrow \mathcal{O}_D^* \rightarrow \mathcal{O}_E^* \rightarrow 1,$$

where the map on the left sends a local section  $a$  to  $1 + a$ . For case (ii), we may assume  $E = \hat{D}$ . By taking the base change to an algebraic closure  $\bar{k}$  of  $k$ , we may assume that  $k$  is algebraically closed. Note that the kernel of  $\phi^*: \text{Pic}_{D/k}^\circ \rightarrow \text{Pic}_{\hat{D}/k}^\circ$  is affine, and it is unipotent if and only if it does not contain a torus (see Corollaries 11 and 12 in [Bosch et al. 1990, Section 9.2]). Then the claim follows from Proposition 4.5 and the surjectivity of  $\phi^*: \text{Pic}_{D/k}^\circ \rightarrow \text{Pic}_{\hat{D}/k}^\circ$ .  $\square$

By combining Lemma 4.3 with Lemma 4.6, we obtain the following:

**Proposition 4.7.** *Let  $\phi: E \rightarrow D$  and  $\tau: D \rightarrow X$  be morphisms between proper schemes over a field  $k$ . If  $\text{char } k > 0$  (respectively,  $\text{char } k = 0$ ), we further assume that  $H^0(\mathcal{O}_X) \cong k$  and the Frobenius map on  $H^1(\mathcal{O}_X)$  is injective (respectively,  $X$  is normal). Then  $\alpha(X, D) = \alpha(X, E)$  holds if one of the following holds:*

- (1) *The canonical immersion  $D_{\text{red}} \hookrightarrow D$  factors through  $\phi$ .*
- (2) *The scheme  $D$  is a curve and there exists a birational morphism  $\hat{D} \rightarrow D_{\text{red}}$  such that the composition  $\hat{D} \rightarrow D_{\text{red}} \hookrightarrow D$  factors through  $\phi$ . Moreover, we further assume  $b_1(\Gamma(D)) = b_1(\Gamma(\hat{D}))$  if  $\text{char } k > 0$ .*

**Remark 4.8.** (1) [Proposition 4.7](#) also holds when  $\phi$  and  $\tau$  are morphisms between compact complex analytic spaces and  $X$  is a normal compact analytic variety in Fujiki's class  $\mathcal{C}$ , because the Picard variety  $\text{Pic}^\circ(X) \cong H^1(X, \mathcal{O}_X)/H^1(X, \mathbb{Z})_{\text{free}}$  is a compact torus.

(2) If  $\text{char } k > 0$  and [Proposition 4.7](#) (1) holds, one can also show  $\alpha(X, D) = \alpha(X, E)$  without using Picard schemes by the same proof of [[Ramanujam 1972](#), Lemma 6].

The following is a generalization of [[Francia 1991](#), Lemma 2.3]:

**Corollary 4.9.** *Let  $X$  be a normal proper variety over a field  $k$ , or normal compact analytic variety in Fujiki's class  $\mathcal{C}$ . Let  $D_1$  and  $D_2$  be closed subschemes of  $X$ . Let  $\pi: X \rightarrow Y$  be a birational morphism to a normal variety  $Y$ . We assume the following three conditions:*

- (i) *The subschemes  $D_1$  and  $D_2$  are not contained in the exceptional locus of  $\pi$  and  $H^1(\mathcal{O}_Y) \cong H^1(\mathcal{O}_X)$ .*
- (ii) *The reduced image of  $D_1$  by  $\pi$  coincides with that of  $D_2$  and it is a curve, which is denoted by  $D$ .*
- (iii) *If  $\text{char } k > 0$ , the Frobenius map on  $H^1(\mathcal{O}_X)$  is injective and  $b_1(\Gamma(D)) = b_1(\Gamma(\hat{D}))$ , where  $\hat{D}$  is the proper transform of  $D$  on  $X$ .*

Then we have  $\alpha(X, D_1) = \alpha(X, D_2) \cong \alpha(Y, D)$ .

*Proof.* We may assume that  $H^0(\mathcal{O}_X) \cong k$  by replacing  $k$  with the field  $H^0(\mathcal{O}_X)$ . Since  $\pi(\hat{D}) = D$ , we may assume  $D_1 = \hat{D}$ . In particular, there is a closed immersion  $D_1 \hookrightarrow D_2$ . From [Proposition 4.7](#), we have

$$\alpha(Y, D) = \alpha(Y, D_2) = \alpha(Y, D_1).$$

On the other hand, it follows from  $H^1(\mathcal{O}_Y) \cong H^1(\mathcal{O}_X)$  that  $\alpha(X, D_i) \cong \alpha(Y, D_i)$ , where  $i = 1, 2$ . Hence, we conclude that

$$\alpha(X, D_1) = \alpha(X, D_2) \cong \alpha(Y, D). \quad \square$$



**Vanishing of  $\alpha(X, D)$ .** In this subsection, we are going to study the vanishing of  $\alpha(X, D)$  when  $D$  is a divisor on a variety  $X$ .

**Definition 4.10.** Let  $X$  be a normal proper variety over a field  $k$  and  $D$  a divisor on  $X$ . The complete linear system  $|D|$  on  $X$  defines a rational map  $\phi_{|D|}: X \dashrightarrow \mathbb{P}^N$ , where  $N = \dim |D|$ . Taking a resolution  $X' \rightarrow X$  of the indeterminacy of  $\phi_{|D|}$  and the Stein factorization, we obtain the morphisms

$$X \leftarrow X' \rightarrow B \rightarrow \mathbb{P}^N,$$

where the middle map is a fiber space. Then we say that  $|D|$  is *composed with a (respectively, rational, irrational) pencil* if  $\dim B = 1$  (respectively, and  $H^1(\mathcal{O}_B) = 0$ ,  $H^1(\mathcal{O}_B) \neq 0$ ).

**Proposition 4.11.** *Let  $X$  be a normal proper surface over a field  $k$  or analytic Moishezon surface. Let  $D$  be an effective and big divisor on  $X$ . Then  $\alpha(X, D) = 0$  (respectively,  $\alpha(X, D)_s = 0$ ) holds if  $\text{char } k = 0$  (respectively,  $\text{char } k > 0$  and either  $k = \bar{k}$  or  $H^1(\mathcal{O}_X)_n = 0$ ).*

*Proof.* We follow Mumford's argument [1967, p. 99]. Since  $H^0(\mathcal{O}_X)$  is a field, we may assume  $H^0(\mathcal{O}_X) = k$ . By taking the base change to a separable closure of  $k$ , we may also assume that  $k$  is separably closed. Let  $\tau: D \hookrightarrow X$  denote the natural immersion.

First we suppose that  $\alpha(X, D) \neq 0$ , i.e.,  $\text{Ker}(\tau^*)^\circ \neq 1$  and that  $H^1(\mathcal{O}_X)_n = 0$  when  $\text{char } k > 0$ . Then we can take a subgroup scheme  $\mu_p \subseteq \text{Ker}(\tau^*)^\circ$ , where  $p$  is a prime number and  $p = \text{char } k$  when  $\text{char } k > 0$ . Indeed, the characteristic 0 case is trivial, and so we may assume that  $\text{char } k = p > 0$ . Then by Lemma 4.1,  $\text{Ker}(\tau^*)[F] \times_k \bar{k}$  is isomorphic to the product  $\prod_i \mu_{p^{n_i}}$ . Since  $k$  is separably closed,  $\text{Ker}(\tau^*)[F]$  is also isomorphic to  $\prod_i \mu_{p^{n_i}}$ . In particular,  $\text{Ker}(\tau^*)^\circ$  contains at least one  $\mu_p$ . Thus, by the natural isomorphism

$$H^1(X_{\text{et}}, (\mathbb{Z}/p\mathbb{Z})_X) \cong \text{Hom}_{\text{GSch}/k}(\mu_p, \text{Pic}_{X/k}),$$

we can take a nontrivial étale cyclic covering  $\pi: Y \rightarrow X$  of degree  $p$  with  $\pi^*D = \sum_{i=1}^p D_i$ , where all  $D_i$  are disjoint and  $D_i \cong D$ .

If  $\alpha(X, D)_s \neq 0$  and the base field  $k$  is algebraically closed of characteristic  $p > 0$ , then there exists a nonzero element  $\eta \in \alpha(X, D)$  such that  $F(\eta) = \eta$ . Thus, we can also take a nontrivial étale cyclic covering  $\pi: Y \rightarrow X$  of degree  $p$  with  $\pi^*D = \sum_{i=1}^p D_i$  corresponding to  $\eta$  by the isomorphism

$$H^1(X_{\text{et}}, (\mathbb{Z}/p\mathbb{Z})_X) \cong \{\eta \in H^1(\mathcal{O}_X) \mid F(\eta) = \eta\}.$$

Let  $D = P + N$  and  $D_i = P_i + N_i$ , respectively, be the Zariski decompositions of  $D$  and  $D_i$ . Then  $\pi^*P = \sum_{i=1}^p P_i$  holds and it is nef and big, which contradicts Lemma 3.3.  $\square$

**Proposition 4.12.** *Let  $X$  be a normal proper surface over a field  $k$  of characteristic 0 or analytic in Fujiki's class  $\mathcal{C}$ . Let  $D$  be an effective divisor on  $X$  with  $\kappa(D) = 1$ . Then  $\alpha(X, D) = 0$  holds if  $|mD|$  is composed with a rational pencil for some  $m > 0$ .*

*Proof.* The proof is identical to that of [Barth et al. 2004, Lemma 12.8]. Since

$$\alpha(X, D) = \alpha(X, mD) \subseteq \alpha(mD - \text{Fix } |mD|)$$

holds for any  $m \geq 1$  from Proposition 4.7, we may assume that  $|D|$  has no fixed parts. Then it is base point free since  $\kappa(D) = 1$ . Let  $f: X \rightarrow B$  be the fibration with connected fibers induced by  $|D|$ . Then we can write  $D = \sum_{i=1}^l F_{t_i}$ , where  $F_{t_i} = f^{-1}(t_i)$  are the fibers of  $f$  at some closed points  $t_i \in B$ . By the Leray spectral sequence

$$H^p(R^q f_* \mathcal{O}_X) \Rightarrow H^{p+q}(\mathcal{O}_X)$$

and the assumption  $H^1(\mathcal{O}_B) = 0$ , we have  $H^1(\mathcal{O}_X) \cong H^0(R^1 f_* \mathcal{O}_X)$ . Let  $\eta$  be an element of  $\alpha(X, D)$ . Then  $\eta|_{F_t} = 0$  for some  $t \in B$  (for example, take  $t = t_1$ ), that is,  $\eta \in \alpha(X, F_t)$ . By Proposition 4.7, we have  $\eta \in \alpha(X, nF_t)$  for any  $n \geq 1$ . Thus, the formal function theorem implies that  $\eta$  maps to 0 by the composition

$$H^1(\mathcal{O}_X) \cong H^0(R^1 f_* \mathcal{O}_X) \rightarrow (R^1 f_* \mathcal{O}_X)_t.$$

Hence, there exists an open neighborhood  $U \subseteq B$  of  $t$  such that  $\eta|_U = 0$ , which implies  $\eta = 0$  since  $R^1 f_* \mathcal{O}_X$  is locally free (note that  $f$  contains no wild fibers by the assumption  $\text{char } k = 0$ ).  $\square$

**Example 4.13.** When  $\text{char } k = p > 0$ , there exist counterexamples to Proposition 4.12 as follows: Let  $G = \mathbb{Z}/p\mathbb{Z}$  be a constant group scheme over an algebraically closed field  $k$  with  $\text{char } k = p > 0$  and  $g \in G$  a generator. Then  $G$  acts on  $\mathbb{A}^1$  as the translation  $g: t \mapsto t + 1$ . This extends to an action on  $\mathbb{P}^1$ . Let  $E$  be an ordinary elliptic curve and take a  $p$ -torsion point  $a \in E(k)$ . Then  $G$  acts freely on  $E$  as  $g: x \mapsto x + a$ . Thus, the diagonal action of  $G$  to  $E \times \mathbb{P}^1$  is free and the quotient  $X := (E \times \mathbb{P}^1)/G$  admits a structure of elliptic surfaces

$$f: X \rightarrow \mathbb{P}^1/G \cong \mathbb{P}^1$$

via the second projection. This admits one wild fiber  $f^{-1}(\infty) = pE_\infty$  at the infinity point  $\infty \in \mathbb{P}^1$ . Then a simple calculation shows that

$$R^1 f_* \mathcal{O}_X \cong \mathcal{O}_{\mathbb{P}^1}(-1) \oplus \mathcal{T},$$

where  $\mathcal{T}$  is a torsion sheaf supported at  $\infty$  with length 1 (see [Katsura and Ueno 1985, p. 313, Section 8]). Now we consider a fiber  $D := f^{-1}(t)$  at a point  $t \neq \infty$ . Since

$$H^1(\mathcal{O}_X) \cong H^0(R^1 f_* \mathcal{O}_X) \cong H^0(\mathcal{T}),$$

we have  $\alpha(X, D) = H^1(\mathcal{O}_X) \cong k$ . We note that the Frobenius map on  $H^1(\mathcal{O}_X)$  is injective since  $H^1(\mathcal{O}_X) \cong H^1(\mathcal{O}_{E_\infty})$  and  $E_\infty$  is ordinary.

Next we consider the higher-dimensional cases. The following is a generalization of [Alzati and Tortora 2002, Theorem 2.1]:

**Proposition 4.14.** *Let  $X$  be a normal projective variety of dimension  $n \geq 2$  over an infinite field  $k$ . Let  $D$  be an effective divisor on  $X$  such that  $D|_S$  is big on a complete intersection surface  $S := H_1 \cap \cdots \cap H_{n-2}$  for general hyperplanes  $H_1, \dots, H_{n-2}$  on  $X$ . Then  $\alpha(X, D) = 0$  (respectively,  $\alpha(X, D)_S = 0$ ) holds if  $\text{char } k = 0$  (respectively,  $\text{char } k > 0$  and either  $k = \bar{k}$  or  $H^1(\mathcal{O}_X)_n = 0$ ).*

*Proof.* The proof is similar to that of Proposition 4.11. Suppose that  $\alpha(X, D) \neq 0$  (respectively,  $\alpha(X, D)_S \neq 0$ ). Then we can also take a nontrivial étale cyclic covering  $\pi : Y \rightarrow X$  of prime degree  $p$  with  $\pi^*D = \sum_{i=1}^p D_i$ , where all  $D_i$  are disjoint and  $D_i \cong D$ . Let  $H_1, \dots, H_{n-2}$  be general hyperplanes on  $X$  such that

$$S := H_1 \cap \cdots \cap H_{n-2}$$

is a normal surface. Then  $S' := \pi^{-1}(S)$  is normal and

$$(\pi|_{S'})^*(D|_S) = D_1|_{S'} + \cdots + D_p|_{S'}$$

is big, which is a contradiction.  $\square$

**Proposition 4.15.** *Let  $X$  be a normal projective variety of dimension  $n \geq 2$  over a field  $k$  of characteristic 0. Let  $D$  be an effective divisor on  $X$  such that  $|mD|$  is composed with a rational pencil for some  $m > 0$ . Then  $\alpha(X, D) = 0$  holds.*

*Proof.* We use induction on the dimension  $n = \dim X$ . The  $n = 2$  case is due to Propositions 4.11 and 4.12. Assume  $n \geq 3$ . Let us take a general hyperplane  $Y$  on  $X$ . Then  $D|_Y$  satisfies  $\kappa(D|_Y) \geq 2$  or  $|mD|$  is composed with a rational pencil. Hence, the claim holds by the natural inclusion  $\alpha(X, D) \hookrightarrow \alpha(Y, D|_Y)$  due to Enriques–Severi–Zariski’s lemma, Proposition 4.14 and the inductive assumption.  $\square$

**Vanishing on  $H^1$ .** Combining Propositions 4.11 and 4.12 with Lemma 3.9, we obtain the following vanishing theorem on normal surfaces:

**Theorem 4.16.** *Let  $X$  be a normal proper surface over a field  $k$  or analytic in Fujiki’s class  $\mathcal{C}$ . Let  $D$  be a chain-connected divisor on  $X$  having a prime component  $C$  with  $H^0(\mathcal{O}_X) \cong H^0(\mathcal{O}_C)$ . Assume that  $|mD|$  is not composed with an irrational pencil and has positive dimension for some  $m > 0$ . If  $\text{char } k > 0$ , we further assume that  $D$  is big and the Frobenius map on  $H^1(\mathcal{O}_X)$  is injective. Then we have  $H^1(\mathcal{O}_X(-D)) = 0$ , or equivalently,  $H^1(\mathcal{O}_X(K_X + D)) = 0$ .*

The following is a positive characteristic analog of [Enokizono 2020, Theorem 4.1] and includes a Kawamata–Viehweg type vanishing theorem for surfaces in positive characteristic:

**Theorem 4.17.** *Let  $X$  be a normal proper geometrically connected surface over a perfect field  $k$  of positive characteristic. Let  $D$  be a big divisor on  $X$  and  $D = P_{\mathbb{Z}} + N_{\mathbb{Z}}$  be the integral Zariski decomposition as in [Enokizono 2020, Theorem 3.5]. Let  $\mathcal{L}_D$  and  $\mathcal{L}'_D$ , respectively, be the rank 1 sheaves on  $N_{\mathbb{Z}}$  defined by the cokernel of the homomorphisms  $\mathcal{O}_X(K_X + P_{\mathbb{Z}}) \rightarrow \mathcal{O}_X(K_X + D)$  and  $\mathcal{O}_X(-D) \rightarrow \mathcal{O}_X(-P_{\mathbb{Z}})$  induced by multiplying a defining section of  $N_{\mathbb{Z}}$ . If  $\dim |D| \geq \dim H^1(\mathcal{O}_X)_n$ , then we have*

$$H^1(X, \mathcal{O}_X(K_X + D)) \cong H^1(N_{\mathbb{Z}}, \mathcal{L}_D) \quad \text{and} \quad H^1(X, \mathcal{O}_X(-D)) \cong H^0(N_{\mathbb{Z}}, \mathcal{L}'_D).$$

*Proof.* Since  $\dim |D| = \dim |P_{\mathbb{Z}}|$ , it suffices to show the vanishing of  $H^1(X, \mathcal{O}_X(-D))$  under the additional assumption that  $D$  is  $\mathbb{Z}$ -positive (see the proof of [Enokizono 2020, Theorem 4.1]). We may assume that  $k$  is algebraically closed by Lemma 3.14. Now, we use a slight modification of Fujita's argument (see [Fujita 1983, Theorem 7.4]). First note that  $H^0(\mathcal{O}_{D_s}) \cong k$  holds for any member  $D_s \in |D|$  from Corollary 3.13. Thus, each nonzero section  $s \in H^0(\mathcal{O}_X(D))$  defines an injection

$$\times s : H^1(\mathcal{O}_X(-D)) \hookrightarrow H^1(\mathcal{O}_X).$$

Moreover, the image of  $\times s$  is contained in  $H^1(\mathcal{O}_X)_n$  by Proposition 4.11. Let

$$U := H^0(\mathcal{O}_X(D)), \quad V := H^1(\mathcal{O}_X(-D)), \quad W := H^1(\mathcal{O}_X)_n, \quad M := \text{Hom}_k(V, W)$$

for simplicity, and consider these as affine varieties over  $k$ . Then the correspondence  $s \mapsto \times s$ , as above, defines a  $k$ -morphism  $\Phi : U \rightarrow M$ . Suppose that  $V \neq 0$ . Note that

$$1 \leq \dim V \leq \dim W < \dim U$$

holds by assumption and the above argument. Then  $\Phi$  induces a morphism

$$\bar{\Phi} : \mathbb{P}(U^*) = |D| \rightarrow \text{Gr}(r, W),$$

where  $\text{Gr}(r, W)$  is the Grassmann variety parametrizing all  $r := \dim V$ -dimensional  $k$ -linear subspaces of  $W$ . Since  $\dim W < \dim U$ , it follows from [Tango 1974, Corollary 3.2] that the morphism  $\bar{\Phi}$  is constant. We denote by  $(I \subseteq W)$  the image of  $\bar{\Phi}$ . Thus,  $\Phi$  induces the morphism

$$\det \Phi : U \xrightarrow{\Phi} \text{Hom}_k(V, I) \xrightarrow{\det} \text{Hom}_k(\wedge^r V, \wedge^r I) \cong \mathbb{A}_k^1,$$

the restriction to  $U \setminus \{0\}$  of which is nonzero everywhere. This contradicts  $\dim U \geq 2$ , since  $(\det \Phi)^{-1}(0)$  must be a divisor.  $\square$

**Corollary 4.18** (Kawamata–Viehweg type vanishing theorem). *Let  $X$  be a normal proper surface over a perfect field  $k$  of positive characteristic with  $H^0(\mathcal{O}_X) \cong k$ . Let  $M$  be a nef and big  $\mathbb{R}$ -divisor on  $X$ . If  $\dim |\ulcorner M \urcorner| \geq \dim H^1(\mathcal{O}_X)_n$ , then*

$$H^i(X, \mathcal{O}_X(K_X + \ulcorner M \urcorner)) = 0$$

for any  $i > 0$ .

For the higher-dimensional cases, by combining Propositions 4.14 and 4.15 with Proposition 3.20, we obtain the following:

**Theorem 4.19** (generalized Ramanujam vanishing theorem). *Let  $X$  be a normal projective variety of dimension  $n \geq 2$  over an algebraically closed field  $k$ . If  $\text{char } k > 0$ , we assume that the Frobenius map on  $H^1(\mathcal{O}_X)$  is injective. Let  $D$  be a chain-connected divisor on  $X$  which satisfies one of the following conditions:*

- (1)  $D|_S$  is big on a complete intersection surface  $S := H_1 \cap \cdots \cap H_{n-2}$  for general hyperplanes  $H_1, \dots, H_{n-2}$ .
- (2)  $|mD|$  is composed with a rational pencil for some  $m > 0$  and  $\text{char } k = 0$ .

Then  $H^1(X, \mathcal{O}_X(-D)) = 0$ .

The following theorem can be seen as a higher-dimensional generalization of Corollary 4.18 and [Miyaoka 1980, Theorem 2.7]:

**Theorem 4.20** (generalized Miyaoka vanishing theorem). *Let  $X$  be a normal projective geometrically connected variety of dimension  $n \geq 2$  over an infinite perfect field  $k$ . Let  $D$  be a divisor on  $X$ . We assume the following three conditions:*

- (i)  $D = \lceil M \rceil + E$  for some  $\mathbb{R}$ -divisor  $M$  and the sum of prime divisors  $E = \sum_{i=1}^m E_i$  (possibly  $m = 0$ ).
- (ii) There exist  $n - 2$  hyperplanes  $H_1, \dots, H_{n-2}$  on  $X$  with  $S := H_1 \cap \cdots \cap H_{n-2}$  a normal surface such that  $M|_S$  is nef,  $D|_S$  is big and for each  $j$ ,

$$H_1 \cdots H_{n-2} \left( \lceil M \rceil + \sum_{i=1}^{j-1} E_i \right) E_j > 0.$$

- (iii)  $\text{char } k = 0$  or  $\dim |D| \geq \dim H^1(\mathcal{O}_X)_n$ .

Then  $H^1(X, \mathcal{O}_X(-D)) = 0$ .

*Proof.* We may assume that  $k$  is algebraically closed since conditions (i), (ii) and (iii) are preserved by any separable base change. We note that for any effective divisor  $D$  satisfying conditions (i) and (ii),  $D|_S$  is big  $\mathbb{Z}$ -positive on a general complete intersection surface  $S = H_1 \cap \cdots \cap H_{n-2}$ . Indeed, this can be checked from the fact that  $D + C$  is  $\mathbb{Z}$ -positive for any  $\mathbb{Z}$ -positive divisor  $D$  and any prime divisor  $C$  on  $S$  with  $DC > 0$ . Thus,  $H^0(\mathcal{O}_D) \cong k$  from Corollary 3.17.

First assume that  $\text{char } k = 0$ . We use induction on  $n = \dim X$ . The  $n = 2$  case is due to [Enokizono 2020, Theorem 4.1 (1)]. Assume that  $n \geq 3$ . Taking a general hyperplane  $Y$  on  $X$ , the restriction of  $D$  to  $Y$

$$D|_Y = \lceil M|_Y \rceil + E|_Y$$

also satisfies conditions (i), (ii) and (iii) in [Theorem 4.20](#). Then the claim follows from the injection

$$H^1(\mathcal{O}_X(-D)) \hookrightarrow H^1(\mathcal{O}_Y(-D|_Y))$$

due to Enriques–Severi–Zariski’s lemma and the inductive assumption.

We assume that  $\text{char } k > 0$ . Note that  $\alpha(X, D)$  is contained in  $H^1(\mathcal{O}_X)_n$  by [Proposition 4.14](#). Hence, the proof is identical to that of [Theorem 4.17](#).  $\square$

**Remark 4.21.** (1) [Theorems 4.16](#) and [4.19](#) can be seen as generalizations of Ramanujam’s 1-connected vanishing for smooth surfaces (see [[Barth et al. 2004](#), Chapter IV, Theorem 12.5]). [Theorem 4.19](#) is also a generalization of [[Ramanujam 1972](#), Theorem 2].

(2) [Theorem 4.20](#) recovers [[Fujino 2017](#), Theorem 3.5.3]. Indeed, for a smooth complete variety  $X$  of dimension  $\geq 2$  and a nef  $\mathbb{R}$ -divisor  $M$  with  $\nu(M) \geq 2$ , we reduce the vanishing  $H^1(X, \mathcal{O}_X(-\ulcorner M \urcorner)) = 0$  to [Theorem 4.20](#) as follows: Take a birational morphism  $\pi : X' \rightarrow X$  from a smooth projective variety by using Chow’s lemma and apply the Leray spectral sequence  $H^p(R^q \pi_* \mathcal{O}_{X'}(-\ulcorner \pi^* M \urcorner)) \Rightarrow H^{p+q}(\mathcal{O}_X(-\ulcorner M \urcorner))$ .

(3) Conditions (i) and (ii) in [Theorem 4.20](#) are satisfied for any divisor  $D$  of the form  $D = \ulcorner M \urcorner$ , where  $M$  is an  $\mathbb{R}$ -divisor which is nef in codimension 1 and satisfies  $\nu(M) \geq 2$  or  $\kappa(D) \geq 2$ .

**Example 4.22.** (1) Raynaud surfaces [[Raynaud 1978](#); [Mukai 2013](#)] are smooth projective surfaces  $X$  having positive characteristic with ample divisors  $D$  with  $H^1(X, \mathcal{O}_X(-D)) \neq 0$ . By construction, we can take the divisor  $D$  effective. Thus, these examples show that [Theorem 4.17](#) does not hold if we only assume the weaker condition that  $|D| \neq \emptyset$ .

(2) The examples constructed in [[Cascini and Tanaka 2018](#)] (respectively, in [[Bernasconi 2021](#)]) are smooth (respectively, klt) rational surfaces  $X$  with a divisor  $D$  of the form  $D = \ulcorner M \urcorner$ , a nef and big  $\mathbb{Q}$ -divisor  $M$  (respectively, an ample divisor  $D$ ) on  $X$  such that  $H^1(X, \mathcal{O}_X(-D)) \neq 0$ . Here, by [Theorem 4.17](#), we cannot take the divisor  $D$  effective because  $H^1(\mathcal{O}_X) = 0$  in this case.

(3) If the base field  $k$  is not perfect, [Theorem 4.17](#) does not hold. Indeed, Mad-dock [[2016](#)] constructed a regular del Pezzo surface  $X_2$  over an imperfect field  $k$  of characteristic 2 with  $\dim H^1(\mathcal{O}_{X_2}) = 1$  and  $K_{X_2}^2 = 2$ . Then, by the Riemann–Roch theorem,  $\dim |-K_{X_2}| \geq \dim H^1(\mathcal{O}_{X_2}) = 1$ .

(4) For any  $i \geq 2$ , there exists a normal projective variety  $X$  of dimension  $\geq 3$  and an ample Cartier divisor  $D$  on  $X$  such that  $H^i(X, \mathcal{O}_X(-D)) \neq 0$  even for characteristic 0 [[Sommese 1986](#)]. Thus, the similar results of [Theorem 4.20](#) for the vanishing on  $H^i$ , where  $i \geq 2$ , cannot be expected.

## 5. Adjoint linear systems for effective divisors

We are now going to apply our vanishing theorems to the study of adjoint linear systems on normal surfaces. In this section, let  $X$  be a normal proper surface over a field  $k$  or a normal compact analytic surface in Fujiki's class  $\mathcal{C}$ . First, let us recall the invariant  $\delta_\zeta(\pi, Z)$  for the germ of a cluster  $(X, \zeta)$ .

**Definition 5.1** (see [Enokizono 2020, Definition 5.1]). Let  $\zeta$  be a *cluster* on  $X$ , that is, a 0-dimensional subscheme (or analytic subset) of  $X$ . Let  $\pi: X' \rightarrow X$  be a resolution of singularities of  $X$  contained in  $\zeta$  and  $Z > 0$  be an effective  $\pi$ -exceptional divisor on  $X'$  with  $\pi_*\mathcal{I}_Z \subseteq \mathcal{I}_\zeta$ . Let  $\Delta$  be the *anticanonical cycle* of  $\pi$ , namely the  $\pi$ -exceptional  $\mathbb{Q}$ -divisor defined by  $\Delta = \pi^*K_X - K_{X'}$ , where  $\pi^*$  is the Mumford pullback of  $\pi$ . Then we define the number  $\delta_\zeta(\pi, Z)$  to be 0 if  $\Delta - Z$  is effective, and  $-(\Delta - Z)^2$  otherwise.

For a cluster  $\zeta$  and an effective divisor  $D > 0$  on  $X$ , we say that the above pair  $(\pi, Z)$  *satisfies the condition  $(E)_{D, \zeta}$*  if  $\pi_*\mathcal{I}_Z \subseteq \mathcal{I}_\zeta$  and  $\pi^*D + \Delta - Z$  is effective.

The first main theorem in this section is as follows:

**Theorem 5.2** (Reider-type theorem I). *Let  $X$  be a normal proper surface over a field  $k$  or analytic in Fujiki's class  $\mathcal{C}$ . Let  $D > 0$  be an effective divisor on  $X$ , and assume there is a chain-connected component  $D_c$  of  $D$  containing a prime divisor  $C$  with  $H^0(\mathcal{O}_C) \cong k$ . Let  $\zeta$  be a cluster on  $X$  along which  $K_X + D$  is Cartier. Let  $(\pi, Z)$  be a pair satisfying condition  $(E)_{D_c, \zeta}$  in Definition 5.1 and  $D' := \pi^*D_c + \Delta - Z$ . Assume that*

$$H^0(\mathcal{O}_X(K_X + D)) \rightarrow H^0(\mathcal{O}_X(K_X + D)|_\zeta)$$

*is not surjective. Then there exists an effective decomposition  $D = A + B$  such that both  $A$  and  $B$  intersect  $\zeta$  and  $AB \leq \frac{1}{4}\delta_\zeta(\pi, Z)$  holds if one of the following holds:*

- (i0)  $\text{char } k = 0$  and  $H^1(\mathcal{O}_X) \cong H^1(\mathcal{O}_{X'})$ .
- (ip)  $\text{char } k > 0$  and either  $H^1(\mathcal{O}_{X'}) = 0$  or  $H^1(\mathcal{O}_{X'})_n = 0$  and  $b_1(\Gamma(\hat{D}_c)) = b_1(\Gamma(D_c))$ , where  $\hat{D}_c$  is the proper transform of  $D_c$  on  $X'$ .
- (ii0)  $\text{char } k = 0$ ,  $\kappa(D') \geq 1$  and  $|mD'|$  is not composed with irrational pencils for  $m \gg 0$ .
- (iip)  $\text{char } k > 0$ ,  $H^1(\mathcal{O}_{X'})_n = 0$  and  $D'$  is big.
- (iiip)  $k$  is perfect with  $\text{char } k > 0$ ,  $\dim |D'| \geq \dim H^1(\mathcal{O}_{X'})_n$  and  $D'$  is big.

*Proof.* We first show the claim when  $D$  is chain-connected. Note that the restriction map

$$H^0(\mathcal{O}_X(K_X + D)) \rightarrow H^0(\mathcal{O}_X(K_X + D)|_\zeta)$$

is surjective if and only if the natural homomorphism

$$H^1(\mathcal{I}_\zeta \mathcal{O}_X(K_X + D)) \rightarrow H^1(\mathcal{O}_X(K_X + D))$$

is injective by the long exact sequence. By the Leray spectral sequence

$$E_2^{p,q} = H^p(R^q \pi_* \mathcal{O}_{X'}(K_{X'} + D')) \Rightarrow E^{p+q} = H^{p+q}(\mathcal{O}_{X'}(K_{X'} + D'))$$

and the assumption  $\pi_* \mathcal{I}_Z \subseteq \mathcal{I}_\zeta$ , the injectivity of

$$H^1(\mathcal{I}_\zeta \mathcal{O}_X(K_X + D)) \rightarrow H^1(\mathcal{O}_X(K_X + D))$$

follows from that of the natural homomorphism

$$H^1(\mathcal{O}_{X'}(K_{X'} + D')) \rightarrow H^1(\mathcal{O}_{X'}(K_{X'} + D' + Z)).$$

By the Serre duality, the injectivity of

$$H^1(\mathcal{O}_{X'}(K_{X'} + D')) \rightarrow H^1(\mathcal{O}_{X'}(K_{X'} + D' + Z))$$

is equivalent to the surjectivity of

$$H^1(\mathcal{O}_{X'}(-D' - Z)) \rightarrow H^1(\mathcal{O}_{X'}(-D')).$$

If  $\alpha(X', D' + Z) = \alpha(X', D')$ , then  $H^1(\mathcal{O}_{X'}(-D' - Z)) \rightarrow H^1(\mathcal{O}_{X'}(-D'))$  is surjective if and only if the restriction map

$$H^0(\mathcal{O}_{D'+Z}) \rightarrow H^0(\mathcal{O}_{D'})$$

is surjective because of the following exact sequences

$$\begin{array}{ccccccccc} 0 & \rightarrow & H^0(\mathcal{O}_{X'}) & \rightarrow & H^0(\mathcal{O}_{D'+Z}) & \rightarrow & H^1(\mathcal{O}_{X'}(-D' - Z)) & \rightarrow & \alpha(X', D' + Z) & \rightarrow & 0 \\ & & \parallel & & \downarrow & & \downarrow & & \downarrow & & \\ 0 & \rightarrow & H^0(\mathcal{O}_{X'}) & \rightarrow & H^0(\mathcal{O}_{D'}) & \rightarrow & H^1(\mathcal{O}_{X'}(-D')) & \rightarrow & \alpha(X', D') & \rightarrow & 0. \end{array}$$

Now we assume that  $H^0(\mathcal{O}_X(K_X + D)) \rightarrow H^0(\mathcal{O}_X(K_X + D)|_\zeta)$  is not surjective. Note that any one of the conditions (i0), (ip), (ii0) and (iip) implies

$$\alpha(X', D' + Z) = \alpha(X', D')$$

by Propositions 4.11 and 4.12 and Corollary 4.9. Thus, the above argument implies that  $H^0(\mathcal{O}_{D'+Z}) \rightarrow H^0(\mathcal{O}_{D'})$  is not surjective. Hence,  $D'$  is not chain-connected by Lemma 3.9. When condition (iip) holds, Theorem 4.17 implies that  $D'$  is also not chain-connected. Therefore,  $D'$  decomposes into  $D' = A' + B'$  such that  $A'$  is chain-connected and contains the proper transform  $\hat{C}$  of  $C$ ,  $B'$  is nonzero effective and  $-A'$  is nef over  $B'$  by Lemma 3.5. Let us define  $A := \pi_* A'$  and  $B := \pi_* B'$ . Now we show that  $B$  is nonzero and intersects  $\zeta$ . If  $B = 0$ , then  $B'$  is  $\pi$ -exceptional. Replacing  $Z$  by  $Z + B'$ , it follows from the same argument



as above that  $H^0(\mathcal{O}_{D'+Z}) \rightarrow H^0(\mathcal{O}_{D'-B'})$  is not surjective, which contradicts the chain-connectivity of  $A' = D' - B'$ . If  $B \cap \zeta = \emptyset$ , then for any prime component  $E$  of  $B$ , the proper transform  $\hat{E}$  coincides with the Mumford pullback  $\pi^*E$ . Since  $-A'$  is nef over  $B'$ ,

$$-AE = -A'\pi^*E = -A'\hat{E} \geq 0,$$

which contradicts  $D$  being chain-connected. Similarly, one can see that  $A$  intersects  $\zeta$ . Suppose that  $\delta_\zeta(\pi, Z) = 0$ , that is,  $\Delta - Z$  is effective. Then we may assume that  $D' = \lceil \pi^*D \rceil$  by replacing  $Z$  with the effective divisor  $\Delta - \{-\pi^*D\}$ . It follows from [Proposition 3.7](#) that  $D'$  is chain-connected, which is a contradiction. Hence, we have  $\delta_\zeta(\pi, Z) > 0$ . Let us write  $B' = \pi^*B + B_\pi$  for some  $\pi$ -exceptional  $\mathbb{Q}$ -divisor  $B_\pi$  on  $X'$ . Since  $-A'$  is nef over  $B'$ ,

$$0 \leq -A'B' = -AB + (B_\pi - \Delta + Z)B_\pi.$$

Thus, we obtain

$$AB \leq \left( B_\pi - \frac{\Delta - Z}{2} \right)^2 + \frac{\delta_\zeta(\pi, Z)}{4} \leq \frac{\delta_\zeta(\pi, Z)}{4},$$

which completes the proof for the case that  $D$  is chain-connected.

For a general  $D$ , we consider the effective decomposition  $D = D_1 + D_2$ , where  $D_1 := D_c$  is the chain-connected component of  $D$  containing  $C$  and  $D_2 := D - D_1$ . Then  $-D_1$  is nef over  $D_2$ . If  $D_2$  intersects  $\zeta$ , then  $A := D_1$  and  $B := D_2$  satisfy the assertion of the theorem. Thus, we may assume that  $D_2$  and  $\zeta$  are disjoint. Then  $H^0(\mathcal{O}_X(K_X + D_1)) \rightarrow H^0(\mathcal{O}_X(K_X + D_1)|_\zeta)$  is also not surjective. As shown in the first half of the proof, we can take an effective decomposition  $D_1 = A_1 + B_1$  such that both  $A_1$  and  $B_1$  intersect  $\zeta$  and  $A_1B_1 \leq \delta_\zeta(\pi, Z)/4$ . If  $D_2B_1 \leq 0$ , then

$$(D - B_1)B_1 \leq A_1B_1 \leq \frac{\delta_\zeta(\pi, Z)}{4}.$$

Thus,  $A := A_1 + D_2$  and  $B := B_1$  satisfy the claim. If  $D_2B_1 > 0$ , then one can see that  $A := A_1$  and  $B := B_1 + D_2$  satisfy the claim.  $\square$

**Remark 5.3.** (1) The condition  $H^0(\mathcal{O}_C) \cong k$  in [Theorem 5.2](#) is used in the proof only to ensure that the chain-connectivity of  $D'$  implies  $H^0(\mathcal{O}_{D'}) \cong k$ . Hence, if we assume that  $D'$  is big and  $X$  is geometrically connected over a perfect field  $k$ , then the assumption  $H^0(\mathcal{O}_C) \cong k$  is not needed by [Corollary 3.17](#).

(2) In the situation of [Theorem 5.2](#), we further assume that  $\pi_*\mathcal{I}_Z = \mathcal{I}_\zeta$  and  $R^1\pi_*\mathcal{I}_Z = 0$  (e.g.,  $\Delta - Z$  is  $\pi$ - $\mathbb{Z}$ -positive). Then the above proof of the theorem says that  $H^0(\mathcal{O}_X(K_X + D)) \rightarrow H^0(\mathcal{O}_X(K_X + D)|_\zeta)$  is surjective if and only if  $H^0(\mathcal{O}_{D'+Z}) \rightarrow H^0(\mathcal{O}_{D'})$  is surjective, where  $D' := \pi^*D + \Delta - Z$ . This is a generalization of [\[Francia 1991, Theorem 2\]](#).

(3) If we further assume that  $D_c^2 > \delta_\zeta(\pi, Z)$  in [Theorem 5.2](#), then  $2A - D_c$  is automatically big by the construction of  $A$  and  $B$  (see [\[Enokizono 2020, Theorem 5.2\]](#)).

Next we give a variant of Reider-type theorems which is used in [Section 6](#).

**Definition 5.4.** (1) Let  $X$  be a normal complete surface and  $\zeta$  be a cluster on  $X$ . We define the invariants  $q_X$  and  $q_{X,\zeta}$  as

$$q_X := \min\{E^2 \mid E \text{ is an effective divisor on } X \text{ with } E^2 > 0\},$$

$$q_{X,\zeta} := \min\{E^2 \mid E \text{ is an effective divisor on } X \text{ with } E \cap \zeta \neq \emptyset \text{ and } E^2 > 0\}.$$

(2) Let us define a function  $\mu: \mathbb{R}_{>0}^2 \rightarrow \mathbb{R}$  as

$$\mu(x, d) := \min\{x, d\} \left( \frac{d}{\min\{x, d\}} + 1 \right)^2.$$

Note that  $\mu(-, d)$  is a nonincreasing function which takes the minimum value  $4d$  and  $\mu(x, -)$  is monotonically increasing for any fixed numbers  $x$  and  $d$ . Let  $\zeta$  and  $(\pi, Z)$  be as in [Definition 5.1](#). We define the number  $\delta'_\zeta(\pi, Z)$  as

$$\delta'_\zeta(\pi, Z) := \mu(q_{X,\zeta}, \frac{1}{4}\delta_\zeta(\pi, Z)).$$

Note that  $\delta'_\zeta(\pi, Z) \geq \delta_\zeta(\pi, Z)$  with the equality holding if and only if  $q_{X,\zeta} \geq \frac{1}{4}\delta_\zeta(\pi, Z)$ .

The second main theorem in this section is a positive characteristic analog of [\[Enokizono 2020, Theorem 5.4\]](#).

**Theorem 5.5** (Reider-type theorem II). *Let  $X$  be a normal geometrically connected proper surface over a perfect field  $k$  of positive characteristic. Let  $D$  be an effective and nef divisor on  $X$ . Let  $\zeta$  be a cluster on  $X$  along which  $K_X + D$  is Cartier. Let  $(\pi, Z)$  be a pair satisfying condition  $(E)_{D,\zeta}$  in [Definition 5.1](#). We assume that  $D^2 > \delta'_\zeta(\pi, Z)$  (respectively,  $D^2 = \delta'_\zeta(\pi, Z) > \delta_\zeta(\pi, Z)$ ) and*

$$\dim |D'| \geq \dim H^1(\mathcal{O}_{X'}),$$

where  $D' := \pi^*D + \Delta - Z$ . If the restriction map

$$H^0(\mathcal{O}_X(K_X + D)) \rightarrow H^0(\mathcal{O}_X(K_X + D)|_\zeta)$$

is not surjective, then there exists an effective decomposition  $D = A + B$  with  $A, B > 0$  intersecting  $\zeta$  such that  $A - B$  is big,  $B$  is negative semidefinite and  $AB \leq \frac{1}{4}\delta_\zeta(\pi, Z)$  (respectively, or  $B^2 = q_{X,\zeta}$  and  $D \equiv (\delta_\zeta(\pi, Z)/(4q_{X,\zeta}) + 1)B$ ).

*Proof.* Note that  $D' := \pi^*D + \Delta - Z$  is automatically big since  $D^2 > \delta_\zeta(\pi, Z)$ . Thus, the assumption of the theorem implies condition (iii) in [Theorem 5.2](#). Hence, there exists an effective decomposition  $D = A + B$  such that both  $A$  and  $B$  intersect  $\zeta$ ,  $A - B$  is big and  $AB \leq \delta_\zeta(\pi, Z)/4$ , where we note that  $D$  is chain-connected from [Lemma 3.3](#). The rest of the proof is similar to that of [\[Enokizono 2020, Theorem 5.4\]](#).  $\square$

**Corollaries of Reider-type theorems.** In this subsection, we collect corollaries of Theorems 5.2 and 5.5. For simplicity, the base field  $k$  is assumed to be algebraically closed. First we consider the criterion of the basepoint-freeness.

**Definition 5.6.** Let  $X$  be a normal proper surface and  $x \in X$  be a closed point. Let  $\pi : X' \rightarrow X$  be the blow-up at  $x$  if  $x \in X$  is smooth, or the minimal resolution at  $x$  otherwise. Let  $Z > 0$  denote the exceptional  $(-1)$ -curve (respectively, the fundamental cycle of  $\pi$ , the round-up  $\lceil \Delta \rceil$ , the round-down  $\lfloor \Delta \rfloor$ ) if  $x \in X$  is smooth (respectively, Du Val; Kawamata log terminal but not Du Val; not Kawamata log terminal). We simply write by  $\delta_x$  the number  $\delta_x(\pi, Z)$  in Definition 5.1. Then we define the number  $\tau_x$  to be 3 (respectively, 1,  $\dim V_n$ ) if  $x \in X$  is smooth (respectively, Du Val, otherwise), where  $V_n$  is the nilpotent part of the  $k$ -vector space  $V := (R^1\pi_*\mathcal{O}_{X'})_x$  under the Frobenius action.

The following lemma is easy:

**Lemma 5.7.** *Let the situation be as in Definition 5.6 and  $D$  be an effective divisor on  $X$  passing through  $x$  such that  $K_X + D$  is Cartier at  $x$ . Then the following hold:*

- (1)  $\delta_x = 4$  (respectively,  $\delta_x = 2$ ,  $0 < \delta_x < 2$ ,  $\delta_x = 0$ ) if  $x \in X$  is smooth (respectively, Du Val; Kawamata log terminal, but not Du Val; not Kawamata log terminal).
- (2)  $\dim |D'| - \dim H^1(\mathcal{O}_{X'})_n + \tau_x \geq \dim |D| - \dim H^1(\mathcal{O}_X)_n$ , with  $D' := \pi^*D + \Delta - Z$ .

*Proof.* In order to prove (1), we may assume that  $x \in X$  is a Kawamata log terminal singularity. Let  $\Delta = \sum_i a_i E_i$  and  $Z = \sum_i b_i E_i$  denote the irreducible decompositions. Then

$$\begin{aligned} (\Delta - Z)^2 &= (\Delta - Z)\Delta - (\Delta - Z)Z = \sum_i (a_i - b_i)E_i(-K_{X'}) + (K_{X'} + Z)Z \\ &= \sum_i (b_i - a_i)K_{X'}E_i + 2p_a(Z) - 2 \geq -2, \end{aligned}$$

and it is easy to see that equality holds if and only if  $x \in X$  is Du Val. Claim (2) follows from the exact sequence

$$0 \rightarrow H^1(\mathcal{O}_X)_n \rightarrow H^1(\mathcal{O}_{X'})_n \rightarrow V_n$$

induced by the Leray spectral sequence with the Frobenius action.  $\square$

Theorem 5.2 (i0) and (ip) and Lemma 5.7 imply the following criterion of basepoint-freeness:

**Corollary 5.8.** *Let  $X$  be a normal proper surface. Let  $x \in X$  be at most a rational singularity. Let  $L$  be a divisor on  $X$  which is Cartier at  $x$ . We assume that there exists a chain-connected member  $D \in |L - K_X|$  passing through  $x$  satisfying:*

- (i)  $(X, x)$  or  $(D, x)$  is singular.
- (ii)  $D$  is strictly  $(\delta_x/4)$ -connected if  $x \in X$  is Kawamata log terminal.

(iii) *The Frobenius map on  $H^1(\mathcal{O}_X)$  is injective and  $b_1(\Gamma(D)) = b_1(\Gamma(\hat{D}))$  when  $\text{char } k > 0$ , where  $\hat{D}$  is the proper transform of  $D$  by the minimal resolution of  $(X, x)$  when  $(X, x)$  is singular or by the blow-up at  $x$  when  $(X, x)$  is smooth.*

*Then  $x$  is not a base point of  $|L|$ .*

**Remark 5.9.** All of the conditions of  $D$  in [Corollary 5.8](#) are satisfied if  $D$  is an integral curve passing through  $x$ ,  $(X, x)$  or  $(D, x)$  is singular, and  $D$  is analytically irreducible at  $x$  when  $\text{char } k > 0$ .

[Theorem 5.2](#) (iii) and [Lemma 5.7](#) imply the following corollary:

**Corollary 5.10.** *Let  $X$  be a normal proper surface. Let  $x \in X$  be a closed point. Let  $D$  be a nef divisor on  $X$  such that  $K_X + D$  is Cartier at  $x$ . Then  $x$  is not a base point of  $|K_X + D|$  if the following conditions hold:*

- (i) *There exist rational numbers  $\alpha$  and  $\beta$  with  $\alpha \geq \delta_x$  and  $4\beta(1 - \beta/\alpha) \geq \delta_x$  such that  $D^2 > \alpha$  and  $DB \geq \beta$  for any curve  $B$  on  $X$  passing through  $x$ .*
- (ii)  *$\dim |D| \geq \dim H^1(\mathcal{O}_X)_n + \tau_x$  when  $\text{char } k > 0$ .*

*Proof.* Assume to the contrary that  $x$  is a base point of  $|K_X + D|$ . By [Theorem 5.2](#) and [Remark 5.3](#) (3) (or [\[Enokizono 2020, Theorem 5.2\]](#) when  $\text{char } k = 0$ ), there exists a curve  $B$  on  $X$  passing through  $x$  such that  $(D - B)B \leq \delta_x/4$  and  $D - 2B$  is big. It follows from the Hodge index theorem that

$$DB \leq \frac{1}{4}\delta_x + B^2 \leq \frac{1}{4}\delta_x + \frac{(DB)^2}{D^2},$$

that is,  $(DB)^2 - D^2(DB) + D^2\delta_x/4 \geq 0$ . Since  $(D - 2B)D > 0$ ,

$$DB \leq \frac{D^2 - \sqrt{D^2(D^2 - \delta_x)}}{2}.$$

It follows from  $D^2 > \alpha$  and  $DB \geq \beta$  that

$$\beta \leq DB \leq \frac{D^2 - \sqrt{D^2(D^2 - \delta_x)}}{2} < \frac{\alpha - \sqrt{\alpha(\alpha - \delta_x)}}{2}.$$

Thus, we have  $4\beta(1 - \beta/\alpha) < \delta_x$ , which contradicts assumption (i). □

The very ample cases can be obtained similarly.

**Corollary 5.11.** *Let  $X$  be a normal proper surface with at most Du Val singularities. Let  $D$  be a Cartier divisor on  $X$ . Then  $|K_X + D|$  is very ample if the following conditions hold:*

- (i) *There exist rational numbers  $\alpha$  and  $\beta$  with  $\alpha \geq 8$  and  $\beta(1 - \beta/\alpha) \geq 2$  such that  $D^2 > \alpha$  and  $DB \geq \beta$  for any curve  $B$  on  $X$ .*
- (ii)  *$\dim |D| \geq \dim H^1(\mathcal{O}_X)_n + 6$  when  $\text{char } k > 0$ .*

*Proof.* It suffices to show that  $|K_X + D|$  separates any cluster  $\zeta$  on  $X$  such that it is of length 2 and its support contains at least one smooth point of  $X$  or the defining ideal is  $\mathfrak{m}_x^2 \subseteq \mathcal{O}_X$  for some Du Val singularity  $x \in X$ . Now we show this when the support of  $\zeta$  has a single point  $x \in X$  (the case  $\zeta = x + y$ , with  $x \neq y$ , is similar).

First, we assume that  $x \in X$  is smooth. By assumption,  $\zeta$  is a tangent vector at  $x$ . Let  $\pi : X' \rightarrow X$  be the blow-up along  $\zeta$ , that is, the composition of the blow-ups at  $x$  and at the point infinitely near  $x$  corresponding to the tangent vector. Let  $Z$  be the sum of the total transforms of the two exceptional  $(-1)$ -curves. Then one can see that  $\delta_\zeta(\pi, Z) = 8$  and  $\dim |D'| \geq \dim |D| - 6$ , where  $D' := \pi^*D + \Delta - Z$ .

We assume that  $x \in X$  is Du Val. Let  $\pi : X' \rightarrow X$  be the minimal resolution of  $x$  and  $E$  be its fundamental cycle. Putting  $Z := 2E$ , one can see that  $\pi_*\mathcal{O}_{X'}(-Z) = \mathfrak{m}_x^2$ ,  $\delta_\zeta(\pi, Z) = 8$  and  $\dim |D'| \geq \dim |D| - 4$ .

The rest of the proof is similar to that of [Corollary 5.10](#).  $\square$

**Remark 5.12.** One can obtain a similar result to [Corollary 5.11](#) when  $X$  is not necessarily canonical (but need the estimation of  $\delta_\zeta(\pi, Z)$ ). For the direction, see [[Sakai 1990](#); [Kawachi and Mašek 1998](#); [Langer 2000](#)].

The following is a partial answer to the Fujita conjecture for surfaces in positive characteristic (although there are counterexamples to the Fujita conjecture [[Gu et al. 2022](#)]).

**Corollary 5.13.** *Let  $X$  be a projective surface with at most Du Val singularities in positive characteristic. Let  $H$  be an ample Cartier divisor on  $X$ . Then  $|K_X + mH|$  is base point free for any  $m \geq 3$  (or  $m = 2$  and  $H^2 > 1$ ) with  $\dim |mH| \geq 3 + \dim H^1(\mathcal{O}_X)_n$ , and is very ample for any  $m \geq 4$  (or  $m = 3$  and  $H^2 > 1$ ) with  $\dim |mH| \geq 6 + \dim H^1(\mathcal{O}_X)_n$ .*

*Proof.* This follows from [Corollary 5.10](#) with  $(\alpha, \beta) = (4, 2)$  and [Corollary 5.11](#) with  $(\alpha, \beta) = (9, 3)$  (or directly from [Lemma 3.2](#) and [Theorem 5.2](#)).  $\square$

For pluri-(anti)canonical maps, the following hold:

**Corollary 5.14.** *Let  $X$  be a normal projective surface with at most singularities of geometric genera  $p_g \leq 3$  in positive characteristic. Then the following hold:*

- (1) *If  $K_X$  is ample Cartier, then  $|mK_X|$  is base point free for  $m \geq 4$  (or  $m = 3$  and  $K_X^2 > 1$ ) with  $\dim |(m-1)K_X| \geq \dim H^1(\mathcal{O}_X)_n + 3$ .*
- (2) *If  $X$  is canonical and  $K_X$  is ample Cartier, then  $|mK_X|$  is very ample for any  $m \geq 5$  (or  $m = 4$  and  $K_X^2 > 1$ ) with  $\dim |(m-1)K_X| \geq \dim H^1(\mathcal{O}_X)_n + 6$ .*
- (3) *If  $-K_X$  is ample Cartier (that is,  $X$  is canonical del Pezzo), then  $|-mK_X|$  is base point free for  $m \geq 2$  (or  $m = 1$  and  $K_X^2 > 1$ ), and is very ample for any  $m \geq 3$  (or  $m = 2$  and  $K_X^2 > 1$ ).*

- (4) If  $K_X$  is ample with Cartier index  $r \geq 2$ , then  $|mrK_X|$  is base point free for  $m \geq 3$  with  $\dim |(mr-1)K_X| \geq \dim H^1(\mathcal{O}_X)_n + 3$ .
- (5) If  $-K_X$  is ample with Cartier index  $r \geq 2$  (that is,  $X$  is klt del Pezzo), then  $| -mrK_X|$  is base point free for  $m \geq 2$  with  $\dim | -(mr+1)K_X| \geq 3$ .

*Proof.* This follows from Corollaries 5.10 and 5.13. Note that  $\dim |-(m+1)K_X| \geq 6$  automatically holds in case (3) by the Riemann–Roch theorem and that any klt del Pezzo surface is rational. Hence,  $H^1(\mathcal{O}_X) = 0$  by [Tanaka 2015, Theorem 3.5].  $\square$

**Remark 5.15.** (1) When  $X$  is canonical, Corollary 5.14 (1) and (2) were obtained by [Ekedahl 1988, Main theorem, p. 97] without the condition for  $\dim |(m-1)K_X|$ . (2) Corollary 5.14 (3) was shown in [Bernasconi and Tanaka 2022, Proposition 2.14].

For bicanonical maps on smooth surfaces of general type, the following can be shown (compare to [Shepherd-Barron 1991, Theorems 26 and 27]):

**Corollary 5.16.** *Let  $X$  be a smooth minimal projective surface of general type in positive characteristic. Then  $|2K_X|$  is base point free if  $K_X^2 > 4$  and  $\chi(\mathcal{O}_X) \geq 5 - h_s^{0,1}$ , and  $|2K_X|$  defines a birational morphism if  $K_X^2 > 9$ ,  $\chi(\mathcal{O}_X) \geq 8 - h_s^{0,1}$  and  $X$  does not admit genus 2 fibrations, where  $h_s^{0,1}$  is the dimension of the semisimple part  $H^1(\mathcal{O}_X)_s$ .*

*Proof.* The base point free case follows from Theorem 5.2 and the 2-connectedness of  $K_X$  [Bombieri 1973, Lemma 1]. Note that the condition

$$\dim |K_X| \geq \dim H^1(\mathcal{O}_X)_n + 3$$

is equivalent to  $\chi(\mathcal{O}_X) \geq 5 - h_s^{0,1}$ . Next we consider the birational case. If the bicanonical map is not birational (hence, generically finite of degree  $\geq 2$ ), there exist infinitely many clusters  $\zeta = x + y$  of degree 2 with  $x \neq y$  such that  $|2K_X|$  does not separate  $\zeta$ . One can see easily that  $\delta_\zeta(\pi, Z) = 8$  and  $\delta'_\zeta(\pi, Z) = 8$  or  $9$ , where  $\pi : X' \rightarrow X$  is the blow-up along  $\zeta = x + y$  and  $Z = E_x + E_y$  is the sum of two exceptional  $(-1)$ -curves. It follows from Theorem 5.5 that there exists a negative semidefinite curve  $B_\zeta$  intersecting  $\zeta$  such that  $(K_X - B_\zeta)B_\zeta = 2$ , where the equality is due to the 2-connectivity of  $K_X$ . Thus,  $(K_X B_\zeta, B_\zeta^2) = (2, 0)$  or  $(1, -1)$ . Since the number of curves  $B_\zeta$  satisfying the later case is finite, there exist infinitely many curves (but belong to finitely many numerical classes)  $B_\zeta$  satisfying the former case. By applying [Enokizono 2020, Proposition 6.7], see Lemma 6.8, these  $B_\zeta$  define a genus 2 fibration on  $X$ .  $\square$

## 6. Extension theorems in positive characteristic

In this section, let  $X$  be a normal proper geometrically connected surface over an infinite perfect field  $k$  of positive characteristic. We will prove the following

extension theorem, which is a positive characteristic analog of [Enokizono 2020, Theorem 6.1], by using Theorem 5.5 instead of [Enokizono 2020, Theorem 5.4]:

**Theorem 6.1** (extension theorem). *Let  $D > 0$  be an effective divisor on  $X$  and assume that any prime component  $D_i$  of  $D$  has positive self-intersection number. Let  $\varphi: D \rightarrow \mathbb{P}^1$  be a finite separable morphism of degree  $d$ . If  $D^2 > \mu(q_X, d)$  and  $\dim |D| \geq 3d + \dim H^1(\mathcal{O}_X)_n$ , then there exists a morphism  $\psi: X \rightarrow \mathbb{P}^1$  such that  $\psi|_D = \varphi$ .*

**Remark 6.2.** Theorem 6.1 generalizes a result of Serrano [1987, Remark 3.12]. Paoletti proved another variant of extension theorems in positive characteristic by using Bogomolov-type inequalities [Paoletti 1995, Theorem 3.1].

The following two theorems are positive characteristic analogs of [Enokizono 2020, Theorems 6.10 and 6.11] (see [Enokizono 2020, Section 6] for notation and discussions):

**Theorem 6.3** (extension theorem with base points). *Let  $D > 0$  be an effective divisor on  $X$  and assume that any prime component  $D_i$  of  $D$  has positive self-intersection number. Let  $\varphi: D \rightarrow \mathbb{P}^1$  be a finite separable morphism of degree  $d$  which cannot be extended to a morphism on  $X$ . We assume that  $D^2 = \mu(q_X, d)$ ,  $q_X < d$  and  $\dim |D| \geq 3d + \dim H^1(\mathcal{O}_X)_n$ . Then there exists a linear pencil  $\{F_\lambda\}_\lambda$  with  $F_\lambda^2 = q_X$  and no fixed parts such that the induced rational map  $\psi: X \dashrightarrow \mathbb{P}^1$  satisfies  $\psi|_D = \varphi$ .*

**Theorem 6.4** (extension theorem on movable divisors). *Let  $D > 0$  be an effective divisor on  $X$  and assume that all prime components  $D_i$  of  $D$  have nontrivial numerical linear systems and positive self-intersection numbers. Let  $\varphi: D \rightarrow \mathbb{P}^1$  be a finite separable morphism of degree  $d$  on  $X$ . If  $D^2 > \mu(q_{X,\infty}, d)$  (respectively,  $D^2 = \mu(q_{X,\infty}, d)$ ,  $q_{X,\infty} < d$ ) and  $\dim |D| \geq 3d + \dim H^1(\mathcal{O}_X)_n$ , then there exists a morphism  $\psi: X \rightarrow \mathbb{P}^1$  (respectively, or a rational map  $\psi: X \dashrightarrow \mathbb{P}^1$  induced by a linear pencil  $\{F_\lambda\}_\lambda$  with  $F_\lambda^2 = q_{X,\infty}$  and no fixed parts) such that  $\psi|_D = \varphi$ .*

**Proof of the extension theorem.** The proofs of Theorems 6.1, 6.3 and 6.4 are almost identical to those of [Enokizono 2020, Theorems 6.1, 6.10 and 6.11]. We only sketch here the proof of Theorem 6.1 (the remaining cases are left to the reader).

Let  $\Lambda$  be the set of closed points of  $\mathbb{P}^1$  such that  $(\varphi|_{D_{\text{red}}})^{-1}(\lambda)$  is reduced and contained in the smooth loci of  $X$  and  $D_{\text{red}}$ . It is a dense subset of  $\mathbb{P}^1$  since  $X$  is normal and  $\varphi|_D$  is separable. For a closed point  $\lambda \in \mathbb{P}^1$ , we put  $\alpha_\lambda := \varphi^{-1}(\lambda)$ .

**Lemma 6.5** [Enokizono 2020, Lemma 6.4]. *For any  $k$ -rational point  $\lambda \in \Lambda$ , the restriction  $H^0(\mathcal{O}_X(K_X + D)) \rightarrow H^0(\mathcal{O}_X(K_X + D)|_{\alpha_\lambda})$  is not surjective.*

**Lemma 6.6** (see [Enokizono 2020, Lemma 6.5]). *For any  $k$ -rational point  $\lambda \in \Lambda$ , there exist a member  $D_\lambda \in |D|$  and a pair  $(\pi, Z)$  satisfying condition  $(E)_{D_\lambda, \alpha_\lambda}$  in Definition 5.1 such that  $\delta_{\alpha_\lambda}(\pi, Z) = 4d$ .*

*Proof.* As in the proof of [Enokizono 2020, Lemma 6.5], we can take a blow-up  $\pi : X' \rightarrow X$  along  $\alpha_\lambda$  and a  $\pi$ -exceptional divisor  $Z > 0$  such that  $\pi_*\mathcal{I}_Z = \mathcal{I}_{\alpha_\lambda}$  and  $\delta_{\alpha_\lambda}(\pi, Z) = 4d$ . Since  $\dim |D| \geq 3d$ , we can take a member  $D'_\lambda \in |\pi^*D + \Delta - Z|$ . Then  $D_\lambda := \pi_*D'_\lambda$  is a desired one.  $\square$

We fix a  $k$ -rational point  $\lambda \in \Lambda$  arbitrarily. Then  $D_\lambda$ ,  $\alpha_\lambda$  and the pair  $(\pi, Z)$  obtained by Lemma 6.6 satisfy condition  $(E)_{D_\lambda, \alpha_\lambda}$ . Thus, we can apply Theorem 5.5 to this situation since

$$D_\lambda^2 = D^2 > \mu(q_X, d) \geq \delta'_{\alpha_\lambda}(\pi, Z)$$

and  $\dim |D'_\lambda| \geq \dim H^1(\mathcal{O}_{X'})_n$ . Hence, there exists an effective decomposition  $D_\lambda = A_\lambda + B_\lambda$  with  $A_\lambda$  and  $B_\lambda$  intersecting  $\alpha_\lambda$  such that  $A_\lambda - B_\lambda$  is big,  $B_\lambda$  is negative semidefinite and  $A_\lambda B_\lambda \leq d$ . Moreover, the following lemma can be shown similarly to [Enokizono 2020, Lemma 6.6]:

**Lemma 6.7** [Enokizono 2020, Lemma 6.6]. *In the above situation, we have  $B_\lambda^2 = 0$  and  $D \cap B_\lambda \subseteq \alpha_\lambda$  scheme-theoretically.*

Let  $\mathcal{B}$  be the set of all prime divisors  $C$  such that  $C \leq B_\lambda$  for some  $k$ -rational point  $\lambda \in \Lambda$  and  $DC > 0$ . This is an infinite set, because  $D \cap B_\lambda \subseteq \alpha_\lambda$  by Lemma 6.7 and  $\alpha_\lambda \cap \alpha_{\lambda'} = \emptyset$  for  $\lambda \neq \lambda'$ . On the other hand, the set  $\mathcal{B}$  consists of finitely many numerical equivalence classes, say  $B_{(1)}, \dots, B_{(m)}$ , since  $0 < DC \leq DB_\lambda \leq d$  for any  $C \in \mathcal{B}$ . We put

$$\mathcal{B}_{(i)} := \{C \in \mathcal{B} \mid C \equiv B_{(i)}\}.$$

Then there is at least one  $\mathcal{B}_{(i)}$  which has infinite elements. We choose such a  $\mathcal{B}_{(i)}$  and put  $\mathcal{B} := \mathcal{B}_{(i)}$  again.

**Lemma 6.8** [Enokizono 2020, Proposition 6.7]. *Let  $X$  be a normal proper surface over an infinite perfect field  $k$ . Let  $\mathcal{B}$  be an infinite family of prime divisors on  $X$ , any member of which has the same numerical equivalence class  $B$  with  $B^2 = 0$ . Then there exists a fibration  $f : X \rightarrow Y$  onto a smooth curve  $Y$  such that any member of  $\mathcal{B}$  is a fiber of  $f$ .*

By using Lemma 6.8 in this situation, there exists a fibration  $f : X \rightarrow Y$  onto a smooth curve  $Y$  such that any member of  $\mathcal{B}$  is a fiber of  $f$ . Let  $\bar{D}$  denote the scheme-theoretic image of the morphism

$$(f|_D, \varphi) : D \rightarrow Y \times \mathbb{P}^1$$

and  $h : \bar{D} \rightarrow Y$  denote the restriction of the first projection  $Y \times \mathbb{P}^1 \rightarrow Y$  to  $\bar{D}$ .



**Lemma 6.9** [Enokizono 2020, Lemma 6.8].  $h: \bar{D} \rightarrow Y$  is an isomorphism.

Let  $\gamma: Y \rightarrow \mathbb{P}^1$  be the composition of  $h^{-1}$  and the second projection  $\bar{D} \rightarrow \mathbb{P}^1$ . Then  $\varphi: D \rightarrow \mathbb{P}^1$  decomposes into  $\varphi = \gamma \circ f|_D: X \rightarrow Y \rightarrow \mathbb{P}^1$ . Hence,  $\psi := \gamma \circ f$  is the desired one.

## 7. Applications to plane curves

In this section, we are going to apply our extension theorems obtained in Section 6 to the geometry of plane curves.

**Definition 7.1** (strange points for plane curves). Let  $D \subseteq \mathbb{P}^2$  be a plane curve over a field  $k$ . For a  $k$ -rational point  $x \in \mathbb{P}^2$ , we define the open subset  $U_{D,x}$  of  $D$  to be the set of points  $y$  of  $D$  such that the reduced plane curve  $(D_{k(y)})_{\text{red}} \subseteq \mathbb{P}_{k(y)}^2$  is nonsingular at  $y$  and its tangent line  $L_y \subseteq \mathbb{P}_{k(y)}^2$  at  $y$  does not pass through  $x$ . Then we say that  $x$  is *strange* with respect to  $D$  if  $U_{D,x}$  is not dense in  $D$ . If  $\text{char } k = 0$ , all the strange points are  $k$ -rational points on lines contained in  $D$ . If  $D$  is smooth and has strange points, then  $D$  is a line or a conic with  $\text{char } k = 2$  (see [Hartshorne 1977, Chapter IV, Theorem 3.9]). For a nonsingular  $k$ -rational point  $x$  of  $D$ , we can see that  $x$  is not strange if and only if the inner projection  $D \rightarrow \mathbb{P}^1$  from  $x$  is finite and separable.

**Theorem 7.2.** *Let  $D \subseteq \mathbb{P}^2$  be a plane curve of degree  $m \geq 3$  over an arbitrary base field  $k$ . Then there is a one-to-one correspondence between:*

- (i) *the set of nonsingular  $k$ -rational points of  $D$  which is not strange, and*
- (ii) *the set of finite separable morphisms  $D \rightarrow \mathbb{P}^1$  of degree  $m - 1$  up to automorphisms of  $\mathbb{P}^1$ .*

*Moreover, any finite separable morphism  $D \rightarrow \mathbb{P}^1$  has degree greater than or equal to  $m - 1$ .*

*Proof.* Let  $x$  be a nonsingular, nonstrange  $k$ -rational point of  $D$ . Then the inner projection from  $x$  defines a finite separable morphism  $\text{pr}_x: D \rightarrow \mathbb{P}^1$  of degree  $m - 1$ . This correspondence  $x \mapsto \text{pr}_x$  defines a map from the set of (i) to that of (ii), which is injective since  $m \geq 3$ . Thus, in order to prove the first claim, it suffices to show that any finite separable morphism  $D \rightarrow \mathbb{P}^1$  of degree  $m - 1$  is obtained by the inner projection from some  $k$ -rational point of  $D$ . Let  $\varphi: D \rightarrow \mathbb{P}^1$  be such a morphism. If the base field  $k$  is algebraically closed (or infinite and perfect), then by Theorem 6.3 (or [Enokizono 2020, Theorem 6.10] when  $\text{char } k = 0$ ), there exists a rational map  $\psi: \mathbb{P}^2 \dashrightarrow \mathbb{P}^1$  induced by a linear pencil of lines such that  $\psi|_D = \varphi$ . Since  $\varphi$  is a morphism,  $\psi$  is nothing but an inner projection from a  $k$ -rational point. Suppose that  $k$  is not algebraically closed. Taking the base change to an algebraic closure  $\bar{k}$  of  $k$ , we obtain a finite separable morphism  $\varphi_{\bar{k}}: D_{\bar{k}} \rightarrow \mathbb{P}_{\bar{k}}^1$  of degree  $m - 1$ .

From the above argument, this comes from an inner projection from a  $\bar{k}$ -rational point  $x$  of  $D_{\bar{k}}$ . Now, we take a  $k$ -rational point  $\lambda \in \mathbb{P}^1$  and write

$$\varphi_{\bar{k}}^{-1}(\lambda) = \{x_1, \dots, x_l\}$$

as sets. Then these points  $x, x_1, \dots, x_l$  lie on the same line  $L \subseteq \mathbb{P}_{\bar{k}}^2$ . Moreover, the set  $\{x_1, \dots, x_l\}$  is  $G$ -invariant under the Galois action  $G := \text{Gal}(\bar{k}/k)$  on  $\mathbb{P}_{\bar{k}}^2$ . On the other hand, each  $\sigma \in G$  sends the line  $L$  to another line  $\sigma(L)$ , which also contains  $\{x_1, \dots, x_l\}$ . Now we show  $\sigma(L) = L$ , that is,  $L$  is  $G$ -invariant. If  $l \geq 2$ , then this is clear since the line passing through fixed two points is unique. Thus, we may assume  $l = 1$ . Then both  $L$  and  $\sigma(L)$  are tangent lines at  $x_1$  with multiplicity  $m - 1$ , which implies  $L = \sigma(L)$ . By taking another  $k$ -rational point  $\lambda'$  of  $\mathbb{P}^1$  and using the same argument as above, we can take another  $G$ -invariant line  $L'$  in  $\mathbb{P}_{\bar{k}}^2$  such that  $L \cap L' = \{x\}$ . Thus  $x$  is  $G$ -invariant and descends to a  $k$ -rational point  $x^G$  of  $D$ . Since  $x$  is a smooth point of  $D_{\bar{k}}$ , so is  $x^G$ . Since the lines  $L$  and  $L'$  descend to lines  $L^G$  and  $L'^G$  which intersect at  $x^G$ , we conclude that  $\varphi: D \rightarrow \mathbb{P}^1$  is the inner projection from  $x^G$ . The last claim is due to [Theorem 6.1](#) (or [\[Enokizono 2020, Theorem 6.1\]](#) when  $\text{char } k = 0$ ) since  $\mathbb{P}^2$  does not admit any nonconstant morphism to  $\mathbb{P}^1$ .  $\square$

### Appendix: Mumford's intersection form on a normal projective variety

In this appendix, we extend Mumford's intersection form on a normal surface [\[Mumford 1961\]](#) to a higher-dimensional variety over a field  $k$ .

**Theorem A.1.** *Let  $X$  be a normal projective variety of dimension  $n \geq 2$  over a field  $k$ . Then there exists a multilinear form*

$$Q: \underbrace{\text{Pic}(X) \times \cdots \times \text{Pic}(X)}_{n-2} \times \text{Cl}(X) \times \text{Cl}(X) \rightarrow \mathbb{Q},$$

which we call Mumford's intersection form, such that the following conditions hold:

(i)  $Q$  is an extension of the usual intersection form

$$\text{Pic}(X) \times \cdots \times \text{Pic}(X) \times \text{Cl}(X) \rightarrow \mathbb{Z}.$$

(ii)  $Q$  is symmetric with respect to the first  $n - 2$  terms and the last two terms.

(iii)  $Q$  is compatible with the base change to any separable field extension  $k'$  of  $k$ .

(iv) If  $k$  is an infinite field and  $S := H_1 \cap \cdots \cap H_{n-2}$  is a normal surface obtained by the intersection of  $n - 2$  general hyperplanes, then  $Q(H_1, \dots, H_{n-2}, D_1, D_2)$  coincides with Mumford's intersection number of  $D_1|_S$  and  $D_2|_S$  on  $S$ .

**Definition A.2** (Mumford pullback). Let  $X$  be a normal projective variety over an infinite field  $k$ . Let  $\pi: X' \rightarrow X$  be a resolution of  $X$ . Let  $\{E_i\}_i$  denote the

set of  $\pi$ -exceptional prime divisors on  $X'$  such that the center  $C_i := \pi(E_i)$  is of codimension 2. For each  $i$ , let  $F_i$  denote the numerical equivalence class of the 1-cycle

$$\frac{1}{[k(x) : k]} (\pi|_{E_i})^{-1}(x)$$

(a fiber of  $E_i \rightarrow C_i$  “at a rational point”), which is independent of the choice of a general closed point  $x \in C_i$ . For a Weil divisor  $D$  on  $X$ , we define the *Mumford pullback* of  $D$  by  $\pi$ , which is denoted by  $\pi^*D$ , as  $\hat{D} + \sum_i d_i E_i$ , where  $\hat{D}$  is the proper transform of  $D$  on  $X'$  and the coefficients  $d_i \in \mathbb{Q}$  are determined by the equation

$$\left(\hat{D} + \sum_i d_i E_i\right) F_j = 0$$

for each  $j$ . Note that this condition is equivalent to

$$\left(\hat{D} + \sum_i d_i E_i\right) \pi^* H_1 \cdots \pi^* H_{n-2} E_j = 0$$

for some ample divisors  $H_1, \dots, H_{n-2}$  on  $X$  since

$$(H_1 \cdots H_{n-2} C_j) F_j \equiv \pi^* H_1 \cdots \pi^* H_{n-2} E_j.$$

**Remark A.3.** (1) The definition of the Mumford pullback makes sense if the intersection matrix  $(E_i F_j)_{i,j}$  is invertible. The invertibility can be checked as follows: Let  $H_1, \dots, H_{n-2}$  be general hyperplanes on  $X$  such that  $S := H_1 \cap \cdots \cap H_{n-2}$  is a normal surface. Let  $\rho: S' \rightarrow \pi^{-1}(S)$  denote the normalization and  $E'_i$  denote the pullback of  $E_i$  under  $\rho$ . Then  $E'_i$  is a nonzero effective  $(\pi \circ \rho)$ -exceptional divisor on  $S'$ , and thus  $(E'_i E'_j)_{i,j}$  is negative definite. Since

$$E'_i E'_j = \pi^* H_1 \cdots \pi^* H_{n-2} E_i E_j = (H_1 \cdots H_{n-2} C_j) E_i F_j,$$

the matrix  $(E_i F_j)_{i,j}$  is invertible.

(2) The definition of the Mumford pullback seems to be unnatural because all the coefficients of  $\pi$ -exceptional divisors contracting to codimension  $\geq 3$  centers are zero. It seems to be natural to consider that the Mumford pullback is determined modulo  $\pi$ -exceptional divisors contracting to codimension  $\geq 3$  centers. Indeed, the terms of such  $\pi$ -exceptional divisors do not affect the intersection numbers of  $n - 2$  Cartier divisors and two Weil divisors defined later. For more general treatment of Mumford pullbacks, see [Boucksom et al. 2012].

**Definition A.4.** Let  $X$  be a normal projective variety of dimension  $n \geq 2$  over an infinite field  $k$ . Let  $L_1, \dots, L_{n-2}$  be Cartier divisors on  $X$ . Let  $D_1$  and  $D_2$  be Weil divisors on  $X$ .

(1) For a resolution  $\pi: X' \rightarrow X$  of  $X$ , we define  $(L_1 \cdots L_{n-2} D_1 D_2)_\pi$  to be the rational number  $\pi^* L_1 \cdots \pi^* L_{n-2} \pi^* D_1 \pi^* D_2$ .

(2) Let  $\pi: Y' \rightarrow X$  be an alteration from a regular projective variety  $Y'$ . Let  $Y' \xrightarrow{\psi} Y \xrightarrow{\varphi} X$  denote the Stein factorization of  $\pi$ , where  $\psi$  is a resolution of a normal projective variety  $Y$  and  $\varphi$  is finite. Then, we define

$$(L_1 \cdots L_{n-2} D_1 D_2)_\pi := \frac{1}{\deg \varphi} (\varphi^* L_1 \cdots \varphi^* L_{n-2} \varphi^* D_1 \varphi^* D_2)_\psi,$$

where  $\varphi^* D$  is the pullback of a Weil divisor  $D$  by the finite morphism  $\varphi$ .

**Lemma A.5.** *Let  $X, L_1, \dots, L_{n-2}, D_1, D_2$  be as in Definition A.4. Then the numbers  $(L_1 \cdots L_{n-2} D_1 D_2)_\pi$  are independent of the choice of an alteration  $\pi$ .*

*Proof.* We show  $(L_1 \cdots L_{n-2} D_1 D_2)_{\pi_1} = (L_1 \cdots L_{n-2} D_1 D_2)_{\pi_2}$  for two alterations  $\pi_i: Y'_i \rightarrow X$  with  $Y'_i$  regular, where  $i = 1, 2$ . Taking an alteration from a regular variety  $Y'_3$  to the normalization of the main component of  $Y'_1 \times_X Y'_2$  (for existence, see [de Jong 1996]) and replacing  $Y'_i$  by  $Y'_3$ , we may assume that there exists a generically finite morphism  $\rho: Y'_2 \rightarrow Y'_1$  such that  $\pi_1 \circ \rho = \pi_2$ . Let  $Y'_i \xrightarrow{\psi_i} Y_i \xrightarrow{\varphi_i} X_i$  denote the Stein factorization of  $\pi_i$ . Then there exists a finite morphism  $\tau: Y_2 \rightarrow Y_1$  such that  $\varphi_2 = \varphi_1 \circ \tau$ . Now we have

$$\begin{aligned} (L_1 \cdots L_{n-2} D_1 D_2)_{\pi_1} &= \frac{1}{\deg \varphi_1} (\psi_1^* \varphi_1^* L_1 \cdots \psi_1^* \varphi_1^* L_{n-2} \psi_1^* \varphi_1^* D_1 \psi_1^* \varphi_1^* D_2) \\ &= \frac{1}{\deg \varphi_2} (\psi_2^* \varphi_2^* L_1 \cdots \psi_2^* \varphi_2^* L_{n-2} \rho^* \psi_1^* \varphi_1^* D_1 \rho^* \psi_1^* \varphi_1^* D_2) \end{aligned}$$

and

$$(L_1 \cdots L_{n-2} D_1 D_2)_{\pi_2} = \frac{1}{\deg \varphi_2} (\psi_2^* \varphi_2^* L_1 \cdots \psi_2^* \varphi_2^* L_{n-2} \psi_2^* \varphi_2^* D_1 \psi_2^* \varphi_2^* D_2).$$

Thus, it suffices to show that for any Weil divisor  $D$  on  $Y_1$ ,  $\rho^* \psi_1^* D$  equals  $\psi_2^* \tau^* D$  modulo  $\psi_2$ -exceptional divisors contracting to codimension  $\geq 3$  centers. To prove this, it is enough to show that there exist ample divisors  $H_1, \dots, H_{n-2}$  on  $Y_2$  such that

$$\rho^* \psi_1^* D \psi_2^* H_1 \cdots \psi_2^* H_{n-2} E_j = 0$$

for any  $\psi_2$ -exceptional prime divisor  $E_j$  whose center has codimension 2. Now, we take ample divisors  $A_1, \dots, A_{n-2}$  on  $Y_1$  and put  $H_i := \tau^* A_i$ , which are ample since  $\tau$  is finite. Then, we have

$$\rho^* \psi_1^* D \psi_2^* H_1 \cdots \psi_2^* H_{n-2} E_j = \psi_1^* D \psi_1^* A_1 \cdots \psi_1^* A_{n-2} \rho_* E_j = 0,$$

since  $\rho_* E_j$  is  $\psi_1$ -exceptional or 0. □

**Definition A.6** (intersection numbers). Let  $X$  be a normal projective variety of dimension  $n \geq 2$  over a field  $k$ . Let  $L_1, \dots, L_{n-2}$  be Cartier divisors on  $X$ .

Let  $D_1$  and  $D_2$  be Weil divisors on  $X$ . Then we define the *intersection number* of  $L_1, \dots, L_{n-2}, D_1$  and  $D_2$ , which is denoted by  $L_1 \cdots L_{n-2} D_1 D_2$ , as follows:

(1) If the base field  $k$  is infinite, then we define

$$L_1 \cdots L_{n-2} D_1 D_2 := (L_1 \cdots L_{n-2} D_1 D_2)_\pi,$$

where  $\pi : Y' \rightarrow X$  is an alteration with  $Y'$  regular [de Jong 1996].

(2) If  $k$  is finite and  $H^0(\mathcal{O}_X) = k$ , then we take an algebraic closure  $\bar{k}$  of  $k$  and define

$$L_1 \cdots L_{n-2} D_1 D_2 := L_{1, \bar{k}} \cdots L_{n-2, \bar{k}} D_{1, \bar{k}} D_{2, \bar{k}},$$

where we put  $X_{\bar{k}} := X \times_k \bar{k}$  and the divisors  $L_{i, \bar{k}}$  and  $D_{i, \bar{k}}$  are, respectively, the pullbacks of  $L_i$  and  $D_i$  via the projection  $X_{\bar{k}} \rightarrow X$ . Note that  $X_{\bar{k}}$  is normal since  $k$  is perfect.

(3) If  $k$  is finite and  $k_X := H^0(\mathcal{O}_X) \neq k$ , then  $X$  is geometrically integral and geometrically normal over  $k_X$ . Then, we define

$$L_1 \cdots L_{n-2} D_1 D_2 := [k_X : k](L_1 \cdots L_{n-2} D_1 D_2)_X,$$

where  $(L_1 \cdots L_{n-2} D_1 D_2)_X$  is the intersection number on  $X$  over  $k_X$  defined in (2).

*Proof of Theorem A.1.* We define the multilinear form  $Q$  as

$$Q(L_1, \dots, L_{n-2}, D_1, D_2) := L_1 \cdots L_{n-2} D_1 D_2.$$

One can see easily that this is well defined and satisfies the conditions (i), (ii), (iii) and (iv). □

### Acknowledgement

The author is grateful to Prof. Kazuhiro Konno for valuable discussions and for warm encouragements. He would like to thank Hiroto Akaike, Sho Ejiri, Tatsuro Kawakami, Yuya Matsumoto and Shou Yoshikawa for helpful discussions and answering his questions. He also would like to thank Prof. Adrian Langer for pointing out an error of the proof of Lemma A.5. He was partially supported by JSPS Grant-in-Aid for Research Activity Start-up (19K23407) and JSPS Grant-in-Aid for Young Scientists (20K14297).

### References

- [Alzati and Tortora 2002] A. Alzati and A. Tortora, “On connected divisors”, *Adv. Geom.* **2**:3 (2002), 243–258. [MR](#) [Zbl](#)
- [Barth et al. 2004] W. P. Barth, K. Hulek, C. A. M. Peters, and A. Van de Ven, *Compact complex surfaces*, 2nd ed., *Ergeb. Math. Grenzgeb.* (3) **4**, Springer, Berlin, 2004. [MR](#) [Zbl](#)

- [Bernasconi 2021] F. Bernasconi, “Kawamata–Viehweg vanishing fails for log del Pezzo surfaces in characteristic 3”, *J. Pure Appl. Algebra* **225**:11 (2021), art. id. 106727. [MR](#) [Zbl](#)
- [Bernasconi and Tanaka 2022] F. Bernasconi and H. Tanaka, “On del Pezzo fibrations in positive characteristic”, *J. Inst. Math. Jussieu* **21**:1 (2022), 197–239. [MR](#) [Zbl](#)
- [Bombieri 1973] E. Bombieri, “Canonical models of surfaces of general type”, *Inst. Hautes Études Sci. Publ. Math.* **42** (1973), 171–219. [MR](#) [Zbl](#)
- [Bosch et al. 1990] S. Bosch, W. Lütkebohmert, and M. Raynaud, *Néron models*, *Ergeb. Math. Grenzgeb.* (3) **21**, Springer, Berlin, 1990. [MR](#) [Zbl](#)
- [Boucksom et al. 2012] S. Boucksom, T. de Fernex, and C. Favre, “The volume of an isolated singularity”, *Duke Math. J.* **161**:8 (2012), 1455–1520. [MR](#) [Zbl](#)
- [Cascini and Tanaka 2018] P. Cascini and H. Tanaka, “Smooth rational surfaces violating Kawamata–Viehweg vanishing”, *Eur. J. Math.* **4**:1 (2018), 162–176. [MR](#) [Zbl](#)
- [Chambert-Loir 1998] A. Chambert-Loir, “Cohomologie cristalline: un survol”, *Exposition. Math.* **16**:4 (1998), 333–382. [MR](#) [Zbl](#)
- [Di Cerbo and Fanelli 2015] G. Di Cerbo and A. Fanelli, “Effective Matsusaka’s theorem for surfaces in characteristic  $p$ ”, *Algebra Number Theory* **9**:6 (2015), 1453–1475. [MR](#) [Zbl](#)
- [Ekedahl 1988] T. Ekedahl, “Canonical models of surfaces of general type in positive characteristic”, *Inst. Hautes Études Sci. Publ. Math.* **67** (1988), 97–144. [MR](#) [Zbl](#)
- [Enokizono 2020] M. Enokizono, “An integral version of Zariski decompositions on normal surfaces”, preprint, 2020. [arXiv 2007.06519](#)
- [Francia 1991] P. Francia, “On the base points of the bicanonical system”, pp. 141–150 in *Problems in the theory of surfaces and their classification* (Cortona, 1988), *Sympos. Math.* **32**, Academic, London, 1991. [MR](#) [Zbl](#)
- [Fujino 2017] O. Fujino, *Foundations of the minimal model program*, *MSJ Memoirs* **35**, Mathematical Society of Japan, Tokyo, 2017. [MR](#) [Zbl](#)
- [Fujita 1983] T. Fujita, “Semipositive line bundles”, *J. Fac. Sci. Univ. Tokyo Sect. IA Math.* **30**:2 (1983), 353–378. [MR](#) [Zbl](#)
- [Grothendieck 1962] A. Grothendieck, *Fondements de la géométrie algébrique*, Secrétariat mathématique, Paris, 1962. [MR](#) [Zbl](#)
- [Gu et al. 2022] Y. Gu, L. Zhang, and Y. Zhang, “Counterexamples to Fujita’s conjecture on surfaces in positive characteristic”, *Adv. Math.* **400** (2022), art. id. 108271. [MR](#) [Zbl](#)
- [Hara 1998] N. Hara, “A characterization of rational singularities in terms of injectivity of Frobenius maps”, *Amer. J. Math.* **120**:5 (1998), 981–996. [MR](#) [Zbl](#)
- [Hartshorne 1977] R. Hartshorne, *Algebraic geometry*, *Graduate Texts in Mathematics* **52**, Springer, New York, 1977. [MR](#) [Zbl](#)
- [Huybrechts and Lehn 1997] D. Huybrechts and M. Lehn, *The geometry of moduli spaces of sheaves*, *Aspects of Mathematics* **E31**, Friedr. Vieweg & Sohn, Braunschweig, 1997. [MR](#) [Zbl](#)
- [de Jong 1996] A. J. de Jong, “Smoothness, semi-stability and alterations”, *Inst. Hautes Études Sci. Publ. Math.* **83** (1996), 51–93. [MR](#) [Zbl](#)
- [Katsura and Ueno 1985] T. Katsura and K. Ueno, “On elliptic surfaces in characteristic  $p$ ”, *Math. Ann.* **272**:3 (1985), 291–330. [MR](#) [Zbl](#)
- [Kawachi and Mašek 1998] T. Kawachi and V. Mašek, “Reider-type theorems on normal surfaces”, *J. Algebraic Geom.* **7**:2 (1998), 239–249. [MR](#) [Zbl](#)

- [Kawamata et al. 1987] Y. Kawamata, K. Matsuda, and K. Matsuki, “Introduction to the minimal model problem”, pp. 283–360 in *Algebraic geometry* (Sendai, 1985), edited by T. Oda, Adv. Stud. Pure Math. **10**, North-Holland, Amsterdam, 1987. [MR](#) [Zbl](#)
- [Konno 2010] K. Konno, “Chain-connected component decomposition of curves on surfaces”, *J. Math. Soc. Japan* **62**:2 (2010), 467–486. [MR](#) [Zbl](#)
- [Langer 2000] A. Langer, “Adjoint linear systems on normal surfaces, II”, *J. Algebraic Geom.* **9**:1 (2000), 71–92. [MR](#) [Zbl](#)
- [Langer 2015] A. Langer, “Bogomolov’s inequality for Higgs sheaves in positive characteristic”, *Invent. Math.* **199**:3 (2015), 889–920. [MR](#) [Zbl](#)
- [Liedtke et al. 2021] C. Liedtke, G. Martin, and Y. Matsumoto, “Linearly reductive quotient singularities”, preprint, 2021. [arXiv 2102.01067](#)
- [Maddock 2016] Z. Maddock, “Regular del Pezzo surfaces with irregularity”, *J. Algebraic Geom.* **25**:3 (2016), 401–429. [MR](#) [Zbl](#)
- [Miyaoka 1980] Y. Miyaoka, “On the Mumford–Ramanujam vanishing theorem on a surface”, pp. 239–247 in *Journées de Géométrie Algébrique d’Angers* (Angers, 1979), edited by A. Beauville, Sijthoff & Noordhoff, Germantown, MD, 1980. [MR](#) [Zbl](#)
- [Moriwaki 1993] A. Moriwaki, “Frobenius pull-back of vector bundles of rank 2 over nonuniruled varieties”, *Math. Ann.* **296**:3 (1993), 441–451. [MR](#) [Zbl](#)
- [Mukai 2013] S. Mukai, “Counterexamples to Kodaira’s vanishing and Yau’s inequality in positive characteristics”, *Kyoto J. Math.* **53**:2 (2013), 515–532. [MR](#) [Zbl](#)
- [Mumford 1961] D. Mumford, “The topology of normal singularities of an algebraic surface and a criterion for simplicity”, *Inst. Hautes Études Sci. Publ. Math.* **9** (1961), 5–22. [MR](#) [Zbl](#)
- [Mumford 1967] D. Mumford, “Pathologies, III”, *Amer. J. Math.* **89** (1967), 94–104. [MR](#) [Zbl](#)
- [Namba 1979] M. Namba, *Families of meromorphic functions on compact Riemann surfaces*, Lecture Notes in Mathematics **767**, Springer, Berlin, 1979. [MR](#) [Zbl](#)
- [Paoletti 1995] R. Paoletti, “Free pencils on divisors”, *Math. Ann.* **303**:1 (1995), 109–123. [MR](#) [Zbl](#)
- [Ramanujam 1972] C. P. Ramanujam, “Remarks on the Kodaira vanishing theorem”, *J. Indian Math. Soc. (N.S.)* **36** (1972), 41–51. [MR](#) [Zbl](#)
- [Raynaud 1970] M. Raynaud, “Spécialisation du foncteur de Picard”, *Inst. Hautes Études Sci. Publ. Math.* **38** (1970), 27–76. [MR](#) [Zbl](#)
- [Raynaud 1978] M. Raynaud, “Contre-exemple au ‘vanishing theorem’ en caractéristique  $p > 0$ ”, pp. 273–278 in *C. P. Ramanujam — a tribute*, edited by K. G. Ramanathan, Tata Inst. Fund. Res. Studies in Math. **8**, Springer, Berlin, 1978. [MR](#) [Zbl](#)
- [Reid 1976] M. Reid, “Special linear systems on curves lying on a K3 surface”, *J. London Math. Soc. (2)* **13**:3 (1976), 454–458. [MR](#) [Zbl](#)
- [Reider 1988] I. Reider, “Vector bundles of rank 2 and linear systems on algebraic surfaces”, *Ann. of Math. (2)* **127**:2 (1988), 309–316. [MR](#) [Zbl](#)
- [Saint-Donat 1974] B. Saint-Donat, “Projective models of  $K - 3$  surfaces”, *Amer. J. Math.* **96** (1974), 602–639. [MR](#)
- [Sakai 1990] F. Sakai, “Reider–Serrano’s method on normal surfaces”, pp. 301–319 in *Algebraic geometry* (L’Aquila, 1988), edited by A. J. Sommese et al., Lecture Notes in Math. **1417**, Springer, Berlin, 1990. [MR](#) [Zbl](#)
- [Serrano 1987] F. Serrano, “Extension of morphisms defined on a divisor”, *Math. Ann.* **277**:3 (1987), 395–413. [MR](#) [Zbl](#)

- [Shepherd-Barron 1991] N. I. Shepherd-Barron, “Unstable vector bundles and linear systems on surfaces in characteristic  $p$ ”, *Invent. Math.* **106**:2 (1991), 243–262. [MR](#)
- [Sommese 1986] A. J. Sommese, “On the adjunction theoretic structure of projective varieties”, pp. 175–213 in *Complex analysis and algebraic geometry* (Göttingen, 1985), edited by H. Grauert, Lecture Notes in Math. **1194**, Springer, Berlin, 1986. [MR](#) [Zbl](#)
- [Tanaka 2015] H. Tanaka, “The X-method for klt surfaces in positive characteristic”, *J. Algebraic Geom.* **24**:4 (2015), 605–628. [MR](#) [Zbl](#)
- [Tango 1974] H. Tango, “On  $(n - 1)$ -dimensional projective spaces contained in the Grassmann variety  $\text{Gr}(n, 1)$ ”, *J. Math. Kyoto Univ.* **14** (1974), 415–460. [MR](#)
- [Terakawa 1999] H. Terakawa, “The  $d$ -very ampleness on a projective surface in positive characteristic”, *Pacific J. Math.* **187**:1 (1999), 187–199. [MR](#) [Zbl](#)
- [Zhang 2021] Y. Zhang, “The  $d$ -very ampleness of adjoint line bundles on quasi-elliptic surfaces”, preprint, 2021. [arXiv 2103.04268](#)

Received August 21, 2022. Revised March 26, 2023.

MAKOTO ENOKIZONO  
DEPARTMENT OF MATHEMATICS  
COLLEGE OF SCIENCE  
RIKKYO UNIVERSITY  
TOKYO  
JAPAN  
[enokizono@rikkyo.ac.jp](mailto:enokizono@rikkyo.ac.jp)



# CONSTRUCTING KNOTS WITH SPECIFIED GEOMETRIC LIMITS

URS FUCHS, JESSICA S. PURCELL AND JOHN STEWART

**It is known that any tame hyperbolic 3-manifold with infinite volume and a single end is the geometric limit of a sequence of finite volume hyperbolic knot complements. Purcell and Souto showed that if the original manifold embeds in the 3-sphere, then such knots can be taken to lie in the 3-sphere. However, their proof was nonconstructive; no examples were produced. In this paper, we give a constructive proof in the geometrically finite case. That is, given a geometrically finite, tame hyperbolic 3-manifold with one end, we build an explicit family of knots whose complements converge to it geometrically. Our knots lie in the (topological) double of the original manifold. The construction generalises the class of fully augmented links to a Kleinian groups setting.**

## 1. Introduction

In this paper, we construct finite volume hyperbolic 3-manifolds that converge geometrically to infinite volume ones. In 2010, Purcell and Souto proved that every tame infinite volume hyperbolic 3-manifold with a single end that embeds in  $S^3$  is the geometric limit of complements of knots in  $S^3$  [41]. However, that was purely an existence result; the proof shed very little light on what the knots might look like. This paper is much more constructive. Starting with a tame, infinite volume hyperbolic 3-manifold  $M$  with a single end, we give an algorithm to construct a sequence of knots that converge geometrically to  $M$  — with a cost. We can no longer ensure that our knot complements lie in  $S^3$ .

The methods are to generalise the highly geometric fully augmented links in  $S^3$  to lie on surfaces other than  $S^2 \subset S^3$ . This will likely be of interest in its own right. Since their appearance in the appendix by Agol and Thurston in a paper of Lackenby [27], fully augmented links have contributed a great deal to our understanding of the geometry of many knot and link complements with diagrams that project to  $S^2$ . For example they have been used to bound volumes [16] and

---

*MSC2020:* primary 30F40, 57K10, 57K32; secondary 52C26.

*Keywords:* knot, geometric limit, circle packing, Kleinian groups, fully augmented link.

cuspidal shapes [38], give information on essential surfaces [8], crosscap number [22], and short geodesics [34].

Such links on  $S^2$  are amenable to study via hyperbolic geometry because their complements are hyperbolic and contain a pair of totally geodesic surfaces meeting at right angles: a projection surface, coloured white, and a disconnected *shaded surface* consisting of many 3-punctured spheres; see [39]. While essential 3-punctured spheres are geodesic in any hyperbolic 3-manifold, the white projection surface does not remain geodesic when generalising to links on surfaces other than  $S^2$ . However, using machinery from circle packings and Kleinian groups, we are able to construct links with a geometry similar to the projection surface. We note other very recent generalisations of fully augmented links to lie in thickened surfaces, due to Adams *et al.* [3], Kwon [25], and Kwon and Tham [26]. We work within a different manifold, as follows:

Given a compact 3-manifold  $\bar{M}$  with a single boundary component, the *double* of  $\bar{M}$ , denoted  $D(\bar{M})$  is the closed manifold obtained by gluing two copies of  $\bar{M}$  by the identity along  $\partial\bar{M}$ . The first main result of this paper is the following:

**Theorem 1.1.** *Let  $M$  be a geometrically finite hyperbolic 3-manifold of infinite volume that is homeomorphic to the interior of a compact manifold  $\bar{M}$  with a single boundary component. Then there exists a sequence  $M_n$  of finite volume hyperbolic manifolds that are knot complements in  $D(\bar{M})$ , such that  $M_n$  converges geometrically to  $M$ .*

*Moreover, the method is constructive: we construct for  $p \in M$  and any  $R > 0$  and  $\epsilon > 0$  a fully augmented link complement  $M_{\epsilon,R}$  in  $D(\bar{M})$  with a basepoint  $p_{\epsilon,R}$  such that the metric ball  $B(p_{\epsilon,R}, R) \subset M_{\epsilon,R}$  is  $(1 + \epsilon)$ -bilipschitz to the metric ball  $B(p, R) \subset M$ . Performing sufficiently high Dehn filling along the crossing circles of the fully augmented link yields a knot complement, where the Dehn filling slopes can also be determined effectively, so that the resulting knot complement contains a metric ball that is  $(1 + \epsilon)^2$ -bilipschitz to  $B(p, R)$ .*

We prove [Theorem 1.1](#) by first proving the theorem in the convex cocompact case. In [Section 4](#), we extend the result to the geometrically finite case.

The density theorem states that any hyperbolic 3-manifold  $M$  with finitely generated fundamental group is the algebraic limit of a sequence of geometrically finite hyperbolic 3-manifolds; see Ohshika [36] and Namazi and Souto [35]. Namazi and Souto proved a strong version of this theorem [35, Corollary 12.3]: that in fact, the sequence can be chosen such that  $M$  is also the geometric limit. Thus an immediate corollary of [Theorem 1.1](#) is the following:

**Corollary 1.2.** *Let  $M$  be a hyperbolic 3-manifold of infinite volume which is homeomorphic to the interior of a compact manifold  $\bar{M}$  with a single boundary*

component. Then there exists a sequence  $M_n$  of finite volume hyperbolic manifolds that are knot complements in  $D(\overline{M})$ , such that  $M_n$  converges geometrically to  $M$ .

## 2. Background

In this section we review definitions and results that we will need for the construction, particularly terminology and results in Kleinian groups and their relation to hyperbolic 3-manifolds. Further details are contained, for example, in the books [30] and [23].

**2A. Kleinian groups.** Recall that the ideal boundary of  $\mathbb{H}^3$  is homeomorphic to  $S^2$ , which can be viewed as the Riemann sphere, and that the group of isometries  $\text{Isom}(\mathbb{H}^3)$  corresponds to the group of Möbius transformations acting on the boundary. We mostly consider orientation preserving Möbius transformations here, which may be viewed as elements in  $\text{PSL}(2, \mathbb{C})$ .

A discrete subgroup of  $\text{PSL}(2, \mathbb{C})$  is called a *Kleinian group*.

**Definition 2.1.** A point  $x \in S^2$  is a *limit point* of a Kleinian group  $\Gamma$  if there exists a point  $y \in S^2$  such that  $\lim_{n \rightarrow \infty} A_n(y) = x$  for an infinite sequence of distinct elements  $A_n \in \Gamma$ . The *limit set* of  $\Gamma$  is  $\Lambda(\Gamma) = \{x \in S^2 \mid x \text{ is a limit point of } \Gamma\}$ .

The *domain of discontinuity* is the open set  $\Omega(\Gamma) = S^2 \setminus \Lambda(\Gamma)$ . This set is sometimes called the *ordinary set* or *regular set*.

A Kleinian group  $\Gamma$  is often studied by its quotient space:

$$\mathcal{M}(\Gamma) = (\mathbb{H}^3 \cup \Omega(\Gamma)) / \Gamma.$$

If  $\Gamma$  is torsion-free, then  $\mathcal{M}(\Gamma)$  is an oriented manifold with possibly empty boundary  $\partial\mathcal{M}(\Gamma) = \Omega(\Gamma) / \Gamma$ . The interior  $\text{int}(\mathcal{M}(\Gamma)) = \mathbb{H}^3 / \Gamma$  has a complete hyperbolic structure, since its universal cover is  $\mathbb{H}^3$ . The fundamental group of  $\text{int}(\mathcal{M}(\Gamma))$  is isomorphic to  $\Gamma$ . By Ahlfors' finiteness theorem [4], if  $\Gamma$  is a finitely generated torsion-free Kleinian group, then  $\Omega(\Gamma) / \Gamma$  is the union of a finite number of compact Riemann surfaces with at most a finite number of points removed. The boundary  $\partial\mathcal{M}(\Gamma) = \Omega(\Gamma) / \Gamma$  endowed with this conformal structure is called the *conformal boundary* of  $\mathcal{M}(\Gamma)$ . The Teichmüller space  $\mathcal{T}(\partial\mathcal{M}(\Gamma))$  is the product the Teichmüller spaces  $\mathcal{T}(S_i)$  where the  $S_i$  form the components of  $\partial\mathcal{M}(\Gamma)$ .

In fact, the conformal boundary  $\partial\mathcal{M}(\Gamma)$  has a *projective structure*, since it is locally modelled on  $(\widehat{\mathbb{C}}, \text{PSL}(2, \mathbb{C}))$ . A (projective) *circle* on  $\partial\mathcal{M}(\Gamma)$  is a homotopically trivial, embedded  $S^1 \subset \partial\mathcal{M}(\Gamma)$  whose lifts to  $\Omega(\Gamma)$  are circles on  $S^2$ .

**Definition 2.2.** Let  $\Gamma$  be a Kleinian group and let  $D$  be an open disk in  $\Omega(\Gamma)$  whose boundary is a circle  $C$  on  $S^2$ . The circle  $C$  determines a hyperbolic plane in  $\mathbb{H}^3$ . Denote by  $H(D) \subset \mathbb{H}^3$  the closed half-space bounded by this plane that meets  $D$ .

The *convex hull* of  $\Lambda$  is the relatively closed set

$$\text{CH}(\Gamma) = \mathbb{H}^3 - \bigcup_{D \subset \Omega(\Gamma)} H(D).$$

The *convex core* of  $\mathcal{M}(\Gamma)$  is the quotient

$$\text{CC}(\Gamma) = \text{CH}(\Gamma) / \Gamma \subset \text{int}(\mathcal{M}(\Gamma)).$$

**Definition 2.3.** A finitely generated Kleinian group  $\Gamma$  for which the convex core  $\text{CC}(\Gamma)$  has finite volume is called *geometrically finite*.

If the action of  $\Gamma$  on  $\text{CH}(\Gamma)$  is cocompact, then  $\Gamma$  is said to be *convex cocompact*.

A hyperbolic 3-manifold is called *geometrically finite* (resp. *convex cocompact*), if it is isometric to  $\mathbb{H}^3 / \Gamma$  for a geometrically finite (resp. convex cocompact)  $\Gamma$ .

If  $\Gamma$  is convex cocompact and torsion-free, then it follows that  $\partial\mathcal{M}(\Gamma)$  is a (possibly disconnected) compact Riemann surface without punctures.

There are several equivalent definitions of a geometrically finite manifold in 3-dimensions; see Bowditch [9] for a discussion. For example, we will also use the following, which follows from the proof in [9] that GF5 is equivalent to GF3, in Section 4 of that paper:

**Theorem 2.4** (Bowditch [9]). *The torsion-free Kleinian group  $\Gamma$  is geometrically finite if and only if there a finite sided fundamental domain  $\mathcal{F}(\Gamma) \subset \mathbb{H}^3$  for the action of  $\Gamma$  on  $\mathbb{H}^3$ , with the sides of  $\mathcal{F}(\Gamma)$  consisting of geodesic hyperplanes.*

If  $\text{CC}(\Gamma)$  is compact, it must also have finite volume, and so convex cocompact manifolds are geometrically finite. However, geometrically finite manifolds may also contain cusps. Marden showed that a torsion-free Kleinian group  $\Gamma$  is geometrically finite if and only if  $\mathcal{M}(\Gamma)$  is compact outside of horoball neighbourhoods of finitely many rank one and rank two cusps [28]. The rank one cusps correspond to pairs of punctures on  $\partial\mathcal{M}(\Gamma)$ .

**2B. The quasiconformal deformation space.** Consider a finitely generated, discrete subgroup  $\bar{\Gamma}$  of  $\text{Isom}(\mathbb{H}^3)$  such that the normal subgroup (of index at most two)  $\Gamma := \bar{\Gamma} \cap \text{PSL}_2(\mathbb{C})$  is torsion-free. A representation  $\rho: \bar{\Gamma} \rightarrow \text{Isom}(\mathbb{H}^3)$  is a *quasiconformal deformation* of  $\bar{\Gamma}$ , if there is a (orientation-preserving)  $K$ -quasiconformal homeomorphism  $h: S^2 \rightarrow S^2$  for some  $K \geq 1$ , such that we have

$$\rho(\gamma) = h_*(\gamma) := h \circ \gamma \circ h^{-1} : S^2 \rightarrow S^2 \quad \text{for all } \gamma \in \bar{\Gamma}.$$

(We shorten  $K$ -quasiconformal homeomorphism to  $K$ -qc homeomorphism below.)

**Definition 2.5.** The *quasiconformal deformation space*  $QC(\bar{\Gamma})$  of  $\bar{\Gamma}$  is defined as

$$QC(\bar{\Gamma}) := \{\rho \mid \rho \text{ is a quasiconformal deformation of } \bar{\Gamma} / \text{PSL}_2(\mathbb{C})\}.$$

It can be endowed with a Teichmüller metric given by

$$d_T([\rho], [\rho']) := \inf\{\log K \mid \exists \phi \text{ } K\text{-qc homeomorphism with } \rho = \phi \circ \rho' \circ \phi^{-1}\}.$$

We will always endow  $QC(\bar{\Gamma})$  with the topology induced by this metric.

Now let  $\Gamma$  have index two in  $\bar{\Gamma}$ . Then the extension  $\Gamma \subset \bar{\Gamma}$  amounts to an orientation-reversing isometric involution  $\sigma$  on  $\mathcal{M}(\Gamma)$ , as follows: The space  $\mathcal{M}(\bar{\Gamma})$  is a possibly nonorientable orbifold with boundary  $\partial\mathcal{M}(\bar{\Gamma})$ . The orbifold  $\mathcal{M}(\bar{\Gamma})$  can be recovered as  $\mathcal{M}(\Gamma)/\sigma$ . In particular,  $\partial\mathcal{M}(\bar{\Gamma})$  is given by the quotient  $\partial\mathcal{M}(\Gamma)/\sigma$ . Conversely, the Riemann surface double of the Klein surface  $\partial\mathcal{M}(\bar{\Gamma})$  yields  $\partial\mathcal{M}(\Gamma)$  identified by  $\sigma$ . Note that by passing to the Riemann surface double, we obtain a continuous map  $j: \mathcal{T}(\partial\mathcal{M}(\bar{\Gamma})) \rightarrow \mathcal{T}(\partial\mathcal{M}(\Gamma))$  and that restricting gives a natural inclusion map  $QC(\bar{\Gamma}) \rightarrow QC(\Gamma)$  for any  $\Gamma \subset \bar{\Gamma}$ .

The first part of the following theorem follows from work of Bers [7], Kra [24] and Maskit [31] when restricting to torsion-free Kleinian groups.

**Theorem 2.6.** *Let  $\Gamma$  be a torsion-free finitely generated Kleinian group. Then there is a continuous map  $\beta: \mathcal{T}(\partial\mathcal{M}(\Gamma)) \rightarrow QC(\Gamma)$  given by associating to a marked conformal structure on  $\partial\mathcal{M}(\Gamma)$  the corresponding quasiconformal deformation of  $\Gamma$ .*

*Analogously, if  $\bar{\Gamma} \subset \text{Isom}(\mathbb{H}^3)$  is such that  $\Gamma = \bar{\Gamma} \cap \text{PSL}_2(\mathbb{C})$ , then the composition  $\beta \circ j$  is a continuous map  $\mathcal{T}(\partial\mathcal{M}(\bar{\Gamma})) \rightarrow QC(\bar{\Gamma}) \subset QC(\Gamma)$ .*

*Proof.* We recall a proof of the first part given by Kapovich [23, p.187] and then show that the second part follows by the same argument; compare also [23, section 8.15].

Consider elements in  $\mathcal{T}(\partial\mathcal{M}(\Gamma))$  as equivalence classes  $[f: X \rightarrow Y]$  of quasiconformal maps defined on the conformal boundary  $X := \partial\mathcal{M}(\Gamma)$  of the hyperbolic 3-manifold associated to  $\Gamma$ . Such a quasiconformal map  $f$  induces a Beltrami differential  $\mu$  on  $X$ , which lifts to a Beltrami differential  $\mu'$  on  $\Omega(\Gamma)$  that is invariant under the action of  $\Gamma$ . Extending  $\mu'$  by 0 yields a  $\Gamma$ -invariant Beltrami differential  $\bar{\mu}$  defined globally on  $S^2$ . Solving the Beltrami equation for  $\bar{\mu}$  yields a quasiconformal homeomorphism  $h: S^2 \rightarrow S^2$  with  $K(h) = K(f)$ ; it conjugates each  $\gamma \in \Gamma$  to a Möbius transformation since  $\gamma^*\bar{\mu} = \bar{\mu}$ . Thus  $h$  gives a representation  $h_*: \Gamma \rightarrow \text{Isom}(\mathbb{H}^3)$  via  $\gamma \mapsto h \circ \gamma \circ h^{-1}$ . We set  $\beta([f: X \rightarrow Y]) = h_*$ . This map  $\beta$  is well-defined, since equivalent marked Riemann surfaces yield the same conjugacy class of representations of  $\Gamma$  by Sullivan’s rigidity theorem. Moreover, it follows that  $\beta$  is distance nondecreasing, since  $K(h) = K(f)$  for any fixed marking surface  $X$ ; in particular  $\beta$  is continuous.

If now  $\bar{\Gamma} \subset \text{Isom}(\mathbb{H}^3)$  is such that  $\Gamma = \bar{\Gamma} \cap \text{PSL}_2(\mathbb{C})$ , then elements in  $\mathcal{T}(\partial\mathcal{M}(\bar{\Gamma}))$  can be viewed as equivalence classes of equivariant quasiconformal maps  $f$  from  $(X, \sigma)$  to  $(Y, \sigma_Y)$  (defined on  $(X, \sigma)$  associated to  $\bar{\Gamma}$ ) up to equivariant isotopies. Such a map  $f$  induces a  $\sigma$ -invariant Beltrami differential  $\mu$  on  $X$ . As before,  $\mu$  lifts and extends to  $\bar{\mu}$  on  $S^2$ , which is now  $\bar{\Gamma}$ -invariant. If  $\bar{h}$  solves the Beltrami-equation

for  $\bar{\mu}$ , then it conjugates  $\bar{\Gamma}$  to a representation  $\bar{h}_*$  of  $\bar{\Gamma}$ ; in other words, it yields a quasiconformal deformation  $[\bar{h}_*] \in QC(\bar{\Gamma})$  of  $\bar{\Gamma}$  which restricts to  $[h_*] \in QC(\Gamma)$ . Since the map  $j$  obtained by forgetting the involutions is continuous, the claimed result follows.  $\square$

**2C. Geometric convergence of 3-manifolds.** In this section we will discuss what it means for hyperbolic 3-manifolds to converge geometrically. Background can be found in [6; 30; 13; 23].

Let  $B_R(O)$  denote the hyperbolic ball of radius  $R$  centred at an origin  $O \in \mathbb{H}^3$ . Fix such an origin together with a frame in its tangent space (still simply denoted by  $O$ ). Then hyperbolic manifolds with framed basepoints are in bijective correspondence with torsion-free Kleinian groups: A hyperbolic manifold with framed basepoint  $(M, p)$  corresponds to the unique torsion-free Kleinian group  $\Gamma$  such that there is an isometry  $M \rightarrow \mathbb{H}^3/\Gamma$  taking the framed basepoint  $p$  to the image of  $O$  in  $\mathbb{H}^3/\Gamma$ . Under this correspondence a change of framed basepoint corresponds to conjugation of the Kleinian group. We denote the hyperbolic manifold with framed basepoint corresponding to  $\Gamma$  by  $(\mathbb{H}^3/\Gamma, O)$ .

**Definition 2.7.** For  $i = 1, 2$  let  $(N_i, p_i) = (\mathbb{H}^3/\Gamma_i, O)$  be two hyperbolic manifolds with framed basepoints. We say that  $(N_2, p_2)$  is  $(\epsilon, R)$ -close to  $(N_1, p_1)$ , if there is a  $(1 + \epsilon)$ -bilipschitz embedding  $\tilde{f}: \mathbb{H}^3 \supset B_R(O) \rightarrow \mathbb{H}^3$  such that

- $\tilde{f}$  is  $\epsilon$ -close in  $C^0$  to the inclusion, that is  $d_{C^0}(\tilde{f}, id_{\mathbb{H}^3}|_{B_R(O)}) \leq \epsilon$  and
- $\tilde{f}$  descends to an embedding  $f: N_1 \supset B_R(O)/\Gamma_1 \rightarrow N_2$ .

**Definition 2.8.** A sequence of hyperbolic manifolds with framed basepoints  $(M_k, p_k)$  is said to *converge geometrically* to  $(M, p)$ , if for all  $\epsilon, R > 0$ , there is  $k_0 \in \mathbb{N}$  such that for  $k \geq k_0$  we have  $(M_k, p_k)$  is  $(\epsilon, R)$ -close to  $(M, p)$ . Further, we say that a sequence of hyperbolic manifolds  $M_k$  *converges geometrically* to a hyperbolic manifold  $M$  if for some (or equivalently,<sup>1</sup> any) framed basepoint  $p$  on  $M$  there are framed basepoints  $p_k$  on  $M_k$  such that  $(M_k, p_k)$  converges geometrically to  $(M, p)$ . Also, a sequence of embeddings  $f_k: M \rightarrow M_k$  *establishes geometric convergence of  $M_k$  to  $M$* , if for any framed basepoint  $p$  of  $M$  and any  $(\epsilon, R)$  the (lifts of the) maps  $f_k$  show that  $(M_k, f_k(p))$  is  $(\epsilon, R)$ -close to  $(M, p)$  for  $k$  sufficiently large.

**Remark 2.9.** A sequence of framed hyperbolic manifolds with framed basepoints  $(M_k, p_k)$  converges geometrically to  $(M, p)$ , if and only if the corresponding torsion-free Kleinian groups  $\Gamma_k$  converge to  $\Gamma$  in the Chabauty topology.

Indeed, the proof of Theorem E.1.14 in [6] adapts to show that geometric convergence of hyperbolic manifolds with framed basepoints in the sense of [Definition 2.8](#) implies the convergence of the associated Kleinian groups, even though we do not

<sup>1</sup>Note that if  $(M_n, p_n) = (\mathbb{H}^3/\Gamma_n, O)$  converges to  $(M, p) = (\mathbb{H}^3/\Gamma, O)$  and  $p'$  is another framed basepoint on  $M$  corresponding to the image of  $O'$  in  $\mathbb{H}^3$ , then  $(\mathbb{H}^3/\Gamma_n, O')$  converges to  $(M, p')$ .

assume  $\tilde{f}(0) = 0$  or convergence in  $C^\infty$ . On the other hand, geometric convergence of hyperbolic manifolds with framed basepoints in the sense of [6, Section E.1] (or, by Theorem E.1.14 in [6], Chabauty convergence of torsion-free Kleinian groups) implies geometric convergence in the sense of Definition 2.8.

**2D. Controlled equivariant extensions.** We say a quasiconformal homeomorphism  $\phi: S^2 \rightarrow S^2$  conjugates a Kleinian group  $\Gamma_1$  into a Kleinian group  $\Gamma_2$  if the prescription  $\gamma \mapsto \phi \circ \gamma \circ \phi^{-1}$  defines a group isomorphism  $\phi: \Gamma_1 \rightarrow \Gamma_2$ .

The following result is from McMullen [33, Corollary B.23]:

**Theorem 2.10** (visual extension of qc conjugation). *Suppose  $\phi: \partial\mathbb{H}^3 \rightarrow \partial\mathbb{H}^3$  is a  $K$ -quasiconformal homeomorphism conjugating  $\Gamma_1$  into  $\Gamma_2$ . Then the map  $\phi$  has an extension to an equivariant  $K^{3/2}$ -bilipschitz diffeomorphism  $\Phi$  of  $\mathbb{H}^3$ . In particular the manifolds  $\mathcal{M}(\Gamma_1)$  and  $\mathcal{M}(\Gamma_2)$  are diffeomorphic.*

Strictly speaking, according to the conclusion of [33, Corollary B.23], the map  $\Phi$  is an equivariant  $K^{3/2}$ -quasi-isometry. By [33, A.2 p.186], this means that the extension  $\Phi$  is an equivariant Lipschitz map whose differential is bounded by  $K^{3/2}$ . But  $\Phi$  arises from the visual extension of the Beltrami isotopy [33, Theorem B.22], which is obtained by integrating a smooth vector field [33, Theorem B.10]; thus  $\Phi$  is smooth. Since [33, Corollary B.23] also applies to the inverse map  $\phi^{-1}$  and associates to it the map  $\Phi^{-1}$  (by visually extending the reverse Beltrami isotopy), we can conclude that  $\Phi$  is actually a  $K^{3/2}$ -bilipschitz diffeomorphism.

**Corollary 2.11.** *Let  $\epsilon > 0$  and  $R > 0$ . There is  $\delta > 0$  such that if  $\phi: \partial\mathbb{H}^3 \rightarrow \partial\mathbb{H}^3$  is a  $(1 + \delta)$ -quasiconformal homeomorphism fixing  $0, 1, \infty$  and conjugating a torsion-free Kleinian group  $\Gamma$  to  $\Gamma_\phi$ , then its visual extension  $\Phi$  establishes that  $(\mathbb{H}^3/\Gamma_\phi, p_\phi)$  is  $(\epsilon, R)$ -close to  $(\mathbb{H}^3/\Gamma, p)$ . Here both framed basepoints  $p, p_\phi$  are induced by the framed basepoint  $O$  in  $\mathbb{H}^3$ .*

*Proof.* As seen in the proof of [33, Theorem B.21, B.22], the visual extension  $\Phi: \mathbb{H}^3 \cup \partial\mathbb{H}^3 \rightarrow \mathbb{H}^3 \cup \partial\mathbb{H}^3$  of a  $K$ -quasiconformal homeomorphism extends by reflection across  $\partial\mathbb{H}^3$  further to a  $K^{9/2}$ -quasiconformal map  $\bar{\Phi}: S^3 \rightarrow S^3$  fixing  $0, 1, \infty$  on the equatorial sphere  $\partial\mathbb{H}^3 \subset S^3$ .

Now in any dimension  $n \geq 2$  and for any  $L \geq 1$ , the collection of  $L$ -quasiconformal homeomorphisms  $S^n \rightarrow S^n$  fixing three specified points forms a normal family [18, Theorem 6.6.33]. If  $L = 1$ , this consists only of the identity [18, Theorem 6.8.4].

It follows that for  $K = 1 + \delta$  close to 1, the visual extension of a  $K$ -quasiconformal homeomorphism  $\phi$  is a homeomorphism  $\Phi$  of  $\mathbb{H}^3 \cup \partial\mathbb{H}^3$  that is  $C^0$ -close to the identity. In particular, given  $R, \epsilon > 0$  there is  $\delta > 0$ , such that the visual extension  $\Phi$  of any  $(1 + \delta)$ -quasiconformal homeomorphism  $\phi$  fixing  $0, 1, \infty$  is  $\epsilon$ -close to the identity on  $B_R(O) \subset \mathbb{H}^3$ . Furthermore, the quasiconformal homeomorphism

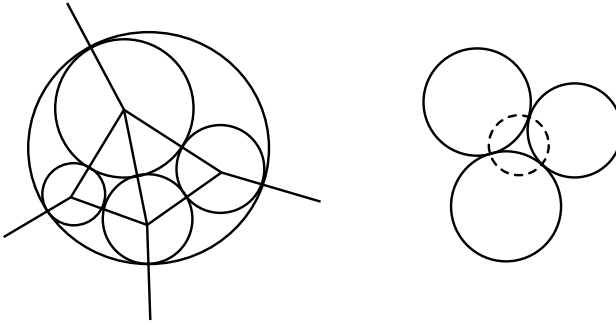

**Figure 1.** Left: example of a circle packing with its nerve, the edges going out all meet at the vertex at  $\infty$ . Right: three circles in a circle packing along with their dual circle, drawn with a dashed line.

$\phi$  is  $(\Gamma, \Gamma_\phi)$ -equivariant by construction of  $\Gamma_\phi$  and thus so is  $\Phi$  by [Theorem 2.10](#). Combining these statements yields the desired result.  $\square$

**2E. Circle packings.** In this section we will define circle packings and present a few important results relating to them. For more information see Stephenson [\[42\]](#). We will eventually use circle packings to glue 3-manifolds and obtain our desired knot and link complements.

**Definition 2.12.** Let  $\Gamma$  be a torsion-free convex cocompact Kleinian group and recall that its conformal boundary  $\partial\mathcal{M}(\Gamma)$  has a natural projective structure. Let  $V$  be a triangulation of  $\partial\mathcal{M}(\Gamma)$ .

A *circle packing* on  $\partial\mathcal{M}(\Gamma)$  with nerve  $V$  is a collection  $P = \{c_v \mid v \text{ vertex of } V\}$  of (projective) circles on  $\partial\mathcal{M}(\Gamma)$  bounding discs with disjoint interiors such that

- (1) each circle  $c_v$  is centred  $v$ ,
- (2) two circles  $c_u, c_v$  are tangent if and only if  $\langle u, v \rangle$  is an edge in  $V$ , and
- (3) three circles  $c_u, c_v, c_w$  bound a positively oriented curvilinear triangle in  $\partial\mathcal{M}(\Gamma)$  if and only if  $\langle u, v, w \rangle$  form a positively oriented face of  $V$ .

More generally, if  $V$  is just a connected graph embedded in  $\partial\mathcal{M}(\Gamma)$ , we say that a collection of (projective) circles satisfying the first two conditions form a *partial circle packing* with nerve  $V$ .

Equivalently, we can consider locally finite,  $\Gamma$ -equivariant (partial) circle packings of  $\Omega(\Gamma)$  obtained as lifts of (partial) circle packings on  $\partial\mathcal{M}(\Gamma)$ .

See [Figure 1](#) for an example of a circle packing.

**Definition 2.13.** Let  $P$  be a circle packing with nerve  $V$  and let  $c_1, c_2, c_3 \in P$  be circles corresponding to a triangle in  $V$ . The curvilinear triangle bounded by these circles is called an *interstice*. There is a unique circle  $c^{(1,2,3)}$  orthogonal to the



circles  $c_1, c_2, c_3$ , intersecting them at their points of tangency. The collection of all such circles corresponding to each triangle in  $V$  we will denote  $P^*$  and we will call the *dual (partial) circle packing* of  $P$ , see [Figure 1](#). Note that the nerves of  $P$  and  $P^*$  are duals as graphs on the surface.

Work of Brooks [\[12\]](#) shows that convex cocompact hyperbolic 3-manifolds admitting a circle packing on the conformal boundary are abundant, in the following sense:

**Theorem 2.14** (circle packings approximate). *Let  $M = \mathbb{H}^3 / \Gamma$  be a convex cocompact hyperbolic 3-manifold. Then, for every  $\epsilon > 0$ , there is an  $e^\epsilon$ -quasiconformal homeomorphism  $\phi$  fixing  $0, 1, \infty$ , conjugating  $\Gamma$  to  $\Gamma_\epsilon$  such that the conformal boundary of  $M_\epsilon = \mathbb{H}^3 / \Gamma_\epsilon$  admits a circle packing.*

*Moreover, the process is constructive: the proof constructs the circle packing. Additionally, for fixed  $r > 0$ , we may ensure none of the circles in the circle packing and none of the triangular interstices have diameter larger than  $r$ . Here we identify  $\partial\mathbb{H}^3$  with the unit sphere in the tangent space  $T_O\mathbb{H}^3$  at the framed basepoint  $O$  in  $\mathbb{H}^3$ .*

This is essentially contained in Brooks’ proof of [\[12, Theorem 2\]](#), but the statement of the theorem is different in Brooks’ paper. In particular, there was no consideration of diameters there, and no worry about construction. We work through the proof below, highlighting the diameters and the constructive nature of the proof.

*Proof of Theorem 2.14.* We begin by choosing effective constants controlling the diameters of the circles and interstices, using a compactness argument. We may uniformise each closed surface component of  $\Omega(\Gamma) / \Gamma$  by a component of  $\Omega(\Gamma)$ . Because  $\Gamma$  is convex cocompact, hence geometrically finite, its action has a finite-sided fundamental domain  $F$  by [Theorem 2.4](#), giving a finite-sided fundamental region for the action of  $\Gamma$  on  $\Omega(\Gamma)$ . The fundamental region will have boundary consisting of vertices and edges, and will be compact.

We need to choose the circles to have bounded radii when seen from  $O$  in  $\mathbb{H}^3$ . To do so, it is convenient to look at hyperbolic space in the Poincaré ball model  $\mathbb{B}^3$  with  $O$  at the origin. Then circles of radius  $r$  in the unit sphere of  $T_O\mathbb{H}^3$  correspond to circles of radius  $r$  the boundary of the Poincaré ball  $\partial\mathbb{B}^3$ .

For given  $r > 0$ , pick a small  $r_0 \leq r/2$  such that any disk  $D$  of radius  $r_0$  meeting  $F$  intersects, apart from  $F$ , at most the immediate neighbouring fundamental domains to  $F$  in  $\Omega(\Gamma)$ . Since  $F$  is compact, it can be covered by finitely many open discs  $D_i$  of radius  $r_0$ . All translates of these  $D_i$  are round disks; therefore the diameter of each translate  $\gamma(D_i)$  is bounded in terms of their area. This implies that there are only finitely many translates  $\gamma(D_i)$  whose diameter is larger than  $r_0$ . Indeed, otherwise there would be an infinite disjoint collection of such translates of diameter

larger than  $r_0$ , but this is impossible since the area of  $S^2$  is finite. It follows that there are only finitely many translates  $F_1, \dots, F_k$  of  $F$  that meet a translate  $\gamma(D_i)$  whose diameter is larger than  $r_0$ .

Therefore we can pick  $r_1 \leq r_0$  such that for any disk  $D$  of radius at most  $r_1$  meeting  $F$  the following holds:  $D$  is contained in one of the  $D_i$ , and any translate of  $D$  meeting  $F_1, \dots, F_k$  has diameter at most  $r_0$ . Note also that translates of  $D$  not meeting  $F_1, \dots, F_k$  automatically have diameter at most  $r_0$  by construction.

Now pack  $F$  with circles of radius at most  $r_1$  by the following constructive process, similar to that of [20, Lemma 2.3]: First choose disjoint circles centred at vertices of  $F$ , taking their images under  $\Gamma$  to ensure equivariance. Then take circles centred along edges, again ensuring translates under  $\Gamma$  agree. Finally, take circles of radius at most  $r_1$  with centres in the interior of the region. Extend this partial circle packing of  $F$  to  $\Omega(\Gamma)$  using the action of  $\Gamma$ , ensuring an equivariant packing.

This yields a  $\Gamma$ -equivariant partial circle packing of  $\Omega(\Gamma)$  consisting of circles of diameter at most  $r_0$  and with regions complementary to the circles consisting of polygonal interstices, with circular arcs as boundaries. At this point, additional circles of radius at most  $r_1$  may be added to  $F$ ; we add sufficiently many to obtain interstitial regions that are either triangles or quads of diameter at most  $r_1$ ; see Brooks [11] or a more detailed exposition in Stewart [43, Lemma 3.7]. Finally, extend again  $\Gamma$ -equivariantly to obtain an equivariant partial packing of  $\Omega(\Gamma)$  with circles of diameter at most  $r_0$ , all of whose interstitial regions are triangles or quads of diameter at most  $r_0 \leq r/2$ .

Consider the group  $\bar{\Gamma}$  generated by  $\Gamma$  and all reflections across the circles in the packing. By Theorem 2.6, the Teichmüller space of the complementary regions, which here are triangles and quads, maps continuously to the quasiconformal deformation space of  $\bar{\Gamma}$  with its Teichmüller metric. The triangular interstitial regions are conformally rigid. The quads have a Teichmüller space homeomorphic to  $\mathbb{R}$ .

Brooks shows in [11] that there is an explicit homeomorphism  $q$  from the Teichmüller space of a quad to  $\mathbb{R}$  with the property that there is a full packing of a quad by finitely many circles if and only if  $q(Q)$  is rational. Thus, arbitrarily close to any quad  $Q$  in the Teichmüller space of quads, there is another quad  $Q'$  with  $q(Q')$  rational. Applying this simultaneously to all the quads complementary to the packing, we obtain arbitrarily close configurations where  $q(Q')$  is rational for all quads  $Q'$ . We may uniquely pack circles into this quad.

By Theorem 2.6, for any  $\epsilon > 0$ , we can thus quasiconformally deform the associated representation  $\rho: \bar{\Gamma} \rightarrow \text{Isom}(\mathbb{H}^3)$  by an  $e^\epsilon$ -quasiconformal homeomorphism  $h$ , normalised to fix the points  $0, 1, \infty$ , to obtain a new convex cocompact representation with image  $\bar{\Gamma}_\epsilon$ , whose complementary quads are all rational. See Figure 2.

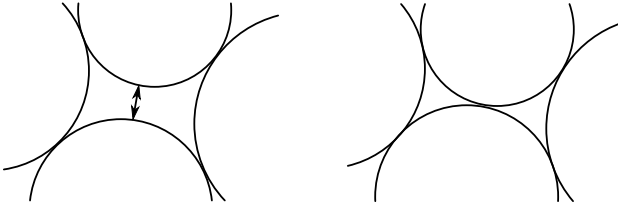

**Figure 2.** Once enough circles are added so a quad is sufficiently small, the space is deformed so that opposite circles become tangent. Doing this for every quad gives a circle packing.

We need to ensure that the quasiconformal homeomorphism does not enlarge the diameters of circles and interstitial regions too much. Indeed, for any  $K \geq 1$ , the  $K$ -quasiconformal homeomorphisms of  $S^2$  fixing  $0, 1, \infty$  form a normal family. Because we fix  $0, 1, \infty$ , this normal family consists of only the identity map when  $K = 1$ . Thus any sequence of  $K_i$ -quasiconformal homeomorphisms of  $S^2$  fixing  $0, 1, \infty$  with  $K_i \rightarrow 1$  converges to the identity map on  $S^2$ ; compare the proof of Corollary 2.11.

Thus, while the  $e^\epsilon$ -quasiconformal deformation may enlarge some of the radii of the circles, provided  $\epsilon$  is small enough, the resulting circles and interstitial regions will have diameter at most  $r$ . □

**Definition 2.15.** Let  $V$  be a graph. A *dimer* on  $V$  is a colouring of edges such that each face is adjacent to exactly one coloured edge.

**Lemma 2.16.** Let  $\Gamma$  be a torsion-free convex cocompact Kleinian group and let  $P$  be a  $\Gamma$ -equivariant circle packing of  $\Omega(\Gamma)$  with nerve  $V$ .

Then there exists a circle packing  $\bar{P}$  with nerve  $\bar{V}$  such that  $V \subset \bar{V}$  and  $\bar{V}$  admits a dimer. Further, the maximal diameter of circles and interstitial regions of  $\bar{P}$  in  $\Omega(\Gamma)$  does not exceed that of  $P$ .

*Proof.* We define the circle packing  $\bar{P}$  by adding the unique circle to each triangular interstice in  $P$  which is tangent to all three circles. The effect on the nerve is to add a vertex to the interior of each triangle of  $V$ , and connect by three edges to the existing vertices of  $V$ , subdividing each triangle into three triangles to form  $\bar{V}$ . Then each triangle in  $\bar{V}$  has exactly one edge coming from  $V$ . Colour this edge. This gives a dimer on  $\bar{V}$ . Observe that because the action of  $\Gamma$  takes triangular interstices to triangular interstices, the result is still equivariant with respect to  $\Gamma$ . Observe that the diameter of circles and interstitial regions at most decrease with this procedure. □

In general there are multiple ways to add circles to a circle packing so that the result admits a dimer. The strength of the above is that it works for any starting circle packing and is simple to execute.

### 3. Construction

In this section, we construct the links of the main theorem.

#### 3A. Scoped manifolds.

**Definition 3.1.** Let  $M = \mathbb{H}^3/\Gamma$  be a convex cocompact hyperbolic 3-manifold. Further assume that  $\partial\mathcal{M}(\Gamma) = \Omega(\Gamma)/\Gamma$  admits a circle packing  $P$  with dual packing  $P^*$ ; then on  $\Omega(\Gamma)$  there is a corresponding equivariant circle packing  $\tilde{P}$  with dual packing  $\tilde{P}^*$ . For the circles  $c_i$  in  $\tilde{P}$  on  $\Omega(\Gamma)$ , there are pairwise disjoint associated open half spaces  $H(c_i) \subset \mathbb{H}^3$  which meet the conformal boundary  $\partial\mathbb{H}^3$  at the interior of  $c_i$ . We then define the *scoped manifold*  $M_P$  to be the manifold formed by removing the half spaces associated with circles in  $\tilde{P}$  and its dual  $\tilde{P}^*$ , and taking the quotient under  $\Gamma$ :

$$M_P = \mathbb{H}^3 - \bigcup_{c \in \tilde{P}, \tilde{P}^*} H(c)/\Gamma.$$

The boundary of  $M_P$  consists of hyperbolic ideal polygons whose faces come from  $\partial H(c)$ ,  $c \in P$  and  $\partial H(c^*)$ ,  $c^* \in P^*$ , and edges come from the intersection of  $\partial H(c)$  and  $\partial H(c^*)$ . Note  $M_P$  is a manifold with corners whose interior is homeomorphic to  $M$ .

**Lemma 3.2.** *Let  $M = \mathbb{H}^3/\Gamma$  be a convex cocompact hyperbolic 3-manifold and  $O \in \mathbb{H}^3$ . Then for any  $\epsilon > 0$ , there exists a  $e^\epsilon$ -quasiconformal homeomorphism  $\phi$  fixing  $0, 1, \infty$  conjugating  $\Gamma$  to  $\Gamma_\epsilon$  satisfying the following:*

- *The associated convex cocompact manifold  $M_\epsilon = \mathbb{H}^3/\Gamma_\epsilon$  admits a circle packing  $P$  on its conformal boundary.*
- *The metric ball  $B(O, R)/\Gamma_\epsilon \subset M_\epsilon$  is completely contained in the corresponding scoped manifold  $(M_\epsilon)_P$ .*
- *Further, we can extend  $P$  to a circle packing  $\bar{P}$  that admits a dimer as in [Lemma 2.16](#), so that  $B(O, R)/\Gamma_\epsilon$  is still completely contained in the scoped manifold  $(M_\epsilon)_{\bar{P}}$ .*

*Proof.* The construction of [Theorem 2.14](#) yields an  $e^\epsilon$ -quasiconformal homeomorphism fixing  $0, 1, \infty$ , and giving  $M_\epsilon$  with circle packing  $P$  on its conformal boundary, where circles and triangular interstices have diameter at most  $r$ . For  $r > 0$  sufficiently small, we may ensure that the half-spaces  $H(c)$  defined by the circles of  $P$  and its dual  $P^*$  have distance at least  $2R$  from  $O$  in  $\mathbb{H}^3$ . Thus we have  $B(O, R)/\Gamma_\epsilon \subset M_\epsilon - \bigcup_{c \in P} H(c) = (M_\epsilon)_P$ .

Finally, using [Lemma 2.16](#), we can extend  $P$  to a circle packing  $\tilde{P}$  which admits a dimer. □

**Proposition 3.3.** *Let  $M$  be a convex cocompact hyperbolic 3-manifold. Further suppose that  $\partial\mathcal{M}(\Gamma)$  admits a circle packing  $P$  with nerve  $K$  that has a fixed dimer. Then the scooped manifold  $M_P$  has the following properties:*

- (1) *The faces on the boundary of  $M_P$  can be checkerboard coloured, white and black.*
- (2) *The white faces consist of totally geodesic ideal polygons.*
- (3) *The black faces consist of totally geodesic ideal triangles. The dimer induces a pairing of the black faces, such that paired black faces share an ideal vertex.*
- (4) *The ideal vertices are all four valent.*
- (5) *The dihedral angle between faces on the boundary is  $\pi/2$ .*

*Proof.* By the definition of scooped manifolds the boundary of  $M_P$  consists of ideal geodesic polygons coming from the boundaries of the half spaces associated with circles in  $P$  and  $P^*$ . The geodesic polygons coming from half spaces associated with circles in  $P$  we colour white, while those coming from  $P^*$  we colour black. Observe that the points of tangency of circles in  $P$  and  $P^*$  are the same, so these points of tangency form the ideal vertices of both the black and white faces. If  $c \in P$  and  $c^* \in P^*$  are circles such that  $c \cap c^* \neq \emptyset$  then  $c$  and  $c^*$  intersect in exactly two points  $u$  and  $v$ ; these points of intersection correspond to ideal points on the boundary of  $M_P$ . There is an edge between  $u$  and  $v$  on  $\partial M_P$  formed by  $H(c) \cap H(c^*)$ . This edge lies between the face corresponding to  $H(c)$  which we have coloured white and  $H(c^*)$  which we have coloured black. Since every edge on  $\partial M_P$  occurs in this manner, we know that every edge lies between a black and white face. Thus we know that the colouring of the faces we have assigned gives a checkerboard colouring of the faces. The fact that ideal vertices are 4-valent follows from the fact that at each ideal vertex there are four circles which meet at this point: two from  $P$  and two from  $P^*$ . Finally, since circles in  $P$  and  $P^*$  meet orthogonally, the dihedral angle at each edge must be  $\pi/2$ .

To see that the black faces are triangles, observe that for every circle  $c^* \in P^*$  we have by definition that  $c^*$  meets exactly three points in  $P$ . These points are the ideal vertices on the black faces corresponding to the half space associated with  $H(c^*)$ .

Now we show how the black faces are paired. Let  $K$  be the nerve of  $P$ , which has a dimer. Then in the dual graph  $K^*$  of  $K$ , we can transfer the colouring of edges in  $K$  to a colouring of edges in  $K^*$ , since edges are sent to edges. Note that  $K^*$  is 3-valent since  $K$  only consists of triangles. Since each face in  $K$  is adjacent to exactly one coloured edge in the dimer, each vertex in  $K^*$  is adjacent to exactly one coloured edge. This gives a pairing on the vertices in  $K^*$  along this edge, which gives a pairing of the circles in  $P^*$ . Thus each black face in  $\partial M_P$  is paired to another black face. See [Figure 3](#).  $\square$

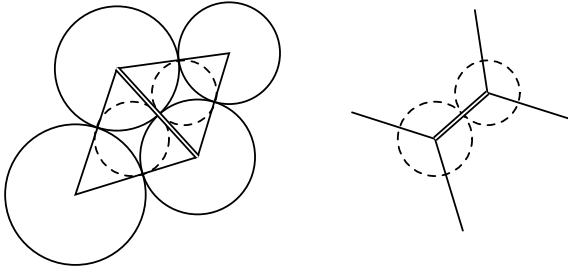

**Figure 3.** Left: Shows four circles in  $P$ , with two dashed circles in  $P^*$ . Part of the nerve of  $P$  is shown on the left with the coloured edge from the dimer drawn with two lines. Right: we have the same two circles in  $P^*$  along with the colouring of the associated part of the nerve of  $P^*$ .

**Lemma 3.4.** *Let  $M = \mathbb{H}^3 / \Gamma$  be a convex cocompact hyperbolic 3-manifold and suppose that  $\partial\mathcal{M}(\Gamma)$  admits a circle packing  $P$ . For each ideal vertex  $v_i \in \{v_1, \dots, v_n\}$  of the scooped manifold  $\partial M_P$ , there is a horoball neighbourhood  $H_i$  such that the  $H_i$  are pairwise disjoint, and  $\partial H_i \cap M_P$  is a Euclidean rectangle.*

*Proof.* Let  $\{v_1, \dots, v_n\}$  be the collection of ideal vertices on  $\partial M_P$ . Note that there are two circles in  $P$  and two circles in  $P^*$  which meet tangentially at each  $v_i$ . Let  $\tilde{M}_P$  denote a lift of  $M_P$  into  $\mathbb{H}^3$  under a covering map, and  $\tilde{v}_i$  a single point in the corresponding lift of  $v_i$  to  $\partial\mathbb{H}^3$ . Two circles of  $P$  and two of  $P^*$  lift to be tangent to  $\tilde{v}_i$ . Let  $\varphi$  denote a Möbius transformation taking  $\tilde{v}_i$  to  $\infty$ . It takes the circles projecting to  $P$  to a pair of parallel lines, and those projecting to  $P^*$  to another pair of parallel lines meeting the first two orthogonally, hence forming a Euclidean rectangle. Then any horoball  $H_h$  of height  $h$  centred at  $\infty$  in  $\mathbb{H}^3$  meets  $\varphi(\tilde{M}_P)$  in  $R_i \times (h, \infty)$ , where  $R_i$  is a Euclidean rectangle. This projects to a rectangular horoball neighbourhood of  $v_i$ . Finally, because there are only finitely many ideal vertices of  $M_P$ , we may choose the horoball about each vertex so that all horoballs are pairwise disjoint, as desired.  $\square$

**Lemma 3.5.** *Let  $M = \mathbb{H}^3 / \Gamma$  be a convex cocompact hyperbolic 3-manifold and suppose that  $\partial\mathcal{M}(\Gamma)$  admits a circle packing  $P$ . Then the scooped manifold  $M_P$  has finite volume.*

*Proof.* Let  $\{H_1, \dots, H_n\}$  be pairwise disjoint horoballs, one for each ideal vertex of  $M_P$ , as in Lemma 3.4. Then removing these horoballs and horoball neighbourhoods from  $M_P$  yields a compact manifold with boundary consisting of finitely many boundaries of horoball neighbourhoods and Euclidean planes  $H_i \cap M_P$ , and finitely many hyperplanes  $\partial H(c) \cap M_P$ , where  $c \in P$  or  $P^*$  is from the circle packing or its dual. This has finite volume.

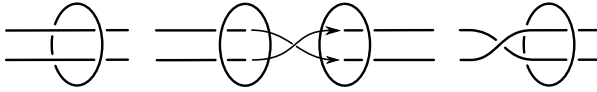

**Figure 4.** Shows how to cut and reglue at a crossing circle to add a half-twist.

Finally, the horoball neighbourhoods must have finite volume, since they are of the form  $R_i \times [1, \infty)$  for  $R_i$  a Euclidean rectangle, as in Lemma 3.4. Thus  $M_P$  has finite volume.  $\square$

**3B. Building link complements.** In this section we describe how to build a hyperbolic link complement using a scooped manifold. The idea behind this construction is inspired by *fully augmented links*, and their relation to circle packings on the sphere. The construction here generalises this by starting with circle packings on a surface of higher genus.

First, we define a generalisation of a fully augmented link.

**Definition 3.6.** Let  $M$  be a 3-manifold and let  $\Sigma$  be an embedded surface of genus  $g \geq 2$  in  $M$ . Then a link  $L$  in a tubular neighbourhood of  $\Sigma$  consisting of components  $K_1, \dots, K_k$  and  $C_1, \dots, C_n$  is called a *fully augmented link on  $\Sigma$*  if it has the following properties:

- (1)  $\bigsqcup_{1 \leq i \leq k} K_i$  is embedded in  $\Sigma$ .
- (2)  $C_j$  bounds a disk  $D_j$  in  $M$  such that  $D_j$  intersects  $\Sigma$  transversely in a single arc, and  $D_j$  meets the union  $\bigsqcup_i K_i$  in exactly two points, for  $1 \leq j \leq n$ .
- (3) A projection of  $L$  to  $\Sigma$  yields a 4-valent *diagram graph* on  $\Sigma$ . We require this diagram to be connected.

The components  $K_i$  are said to lie in the *projection surface*, while the components  $C_j$  are called *crossing circles*.

We may also add a half twist at crossing circles, corresponding to cutting along  $D_j$  and regluing so that the two points of intersection of  $\bigsqcup_i K_i$  with  $D_j$  are swapped. This is shown in Figure 4.

**Definition 3.7.** The link resulting from adding a single half-twist at some or no crossing circles is also called a *fully augmented link on a surface*, even though condition (1) in Definition 3.6 is typically not satisfied anymore after such a half-twist. If the distinction is important, we will say that the link of Definition 3.6 is a fully augmented link on a surface *without half-twists*.

Fully augmented links on surfaces can be quite complicated. A 3-dimensional example on a genus-2 surface is shown in Figure 5.

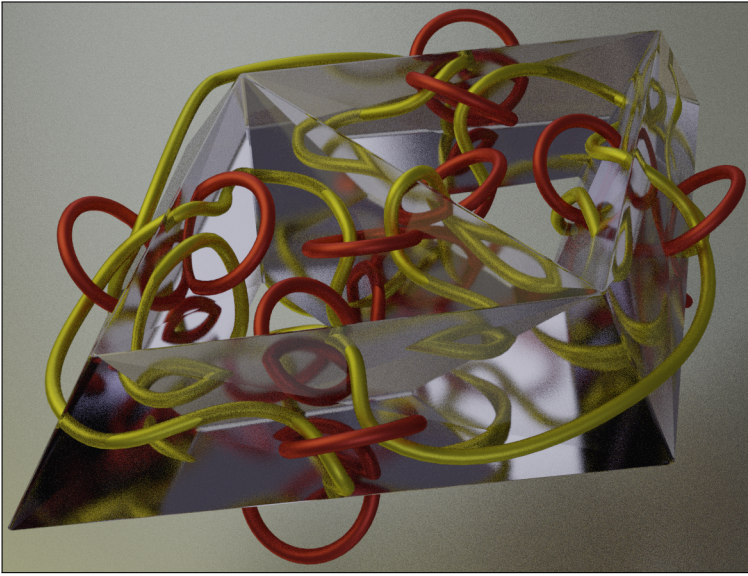

**Figure 5.** An example of a fully augmented link on a genus-2 surface, with crossing circles shown in red. This image was generated in Blender [14].

**Definition 3.8.** Let  $M$  be a manifold with boundary. The *double* of  $M$  is the manifold

$$M \times \{0, 1\} / \sim \quad \text{where } (x, 0) \sim (x, 1) \text{ for all } x \in \partial M.$$

We denote the double of  $M$  by  $\mathfrak{D}(M)$ .

**Proposition 3.9.** *Let  $M$  be an orientable compact manifold with connected boundary. Then the double of  $M$  is not  $S^3$ , unless  $\partial M$  is homeomorphic to  $S^2$ .*

*Proof.* Let  $M_1$  and  $M_2$  denote the two copies of  $M$  in the double of  $M$ , where  $\text{int}(M_1) \cap \text{int}(M_2) = \emptyset$  and  $\partial M_1 = \partial M_2$ . Now for a point  $x \in M_2$  let  $\tilde{x}$  denote the same point in  $M_1$ , or if  $x \in M_1$  then  $\tilde{x}$  denotes the point in  $M_2$ . Then the map  $r : \mathfrak{D}(M) \rightarrow M_1$  defined by

$$r(x) = \begin{cases} x & \text{if } x \in M_1, \\ \tilde{x} & \text{if } x \in M_2, \end{cases}$$

satisfies  $r|_{M_1}$  is the identity. Moreover,  $r$  is continuous since it is continuous on  $M_1$  and  $M_2$  and agrees on  $M_1 \cap M_2 = \partial M_1$ . Thus  $r$  is a retract of  $\mathfrak{D}(M)$  onto  $M_1$ . It follows that the inclusion  $M \hookrightarrow \mathfrak{D}(M)$  induces an injection  $i_* : \pi_1(M) \rightarrow \pi_1(\mathfrak{D}(M))$ .



On the other hand,  $\pi_1(M_1)$  is nontrivial, since its abelianisation  $H_1(M)$  has rank equal to half the rank of  $H_1(\partial M_1)$ , which is  $2g \geq 2$  unless  $\partial M_1 = S^2$ ; see [19, Lemmas 3.5, 3.6]. Thus  $\mathcal{D}(M)$  is not  $S^3$  unless  $\partial M = S^2$ .  $\square$

We are now ready to start our construction.

**Construction 3.10.** Let  $M = \mathbb{H}^3/\Gamma$  be a convex cocompact hyperbolic 3-manifold whose conformal boundary on  $\partial\mathcal{M}(\Gamma)$  admits a circle packing  $P$  with dimer.

By Proposition 3.3, the boundary of the scooped manifold  $M_P$  is checkerboard coloured black and white, with all black faces consisting of paired totally geodesic ideal triangles.

Form the scooped manifold  $M_P$ . Take a second copy  $M'_P$  of  $M_P$  with the opposite orientation and identify each white face of  $M_P$  with its copy in  $M'_P$  via the identity map identifying these faces.

Black faces in  $M_P$  are each paired in  $M_P$  by the dimer, with the coloured edge of the dimer running over a pair of ideal vertices in the two triangles. Glue these paired ideal triangles by a hyperbolic isometry, folding over the ideal vertex meeting the dimer. Do the same for the paired black triangles in  $M'_P$ .

**Theorem 3.11.** *Let  $M = \mathbb{H}^3/\Gamma$  be a convex cocompact hyperbolic 3-manifold. Suppose the conformal boundary  $\partial\mathcal{M}(\Gamma)$  admits a circle packing with a dimer. Then Construction 3.10 above yields a finite volume hyperbolic 3-manifold  $N$  that is the complement of a fully augmented link  $L$  on  $\partial\mathcal{M}(\Gamma)$  in  $\mathcal{D}(\mathcal{M}(\Gamma))$ , without half-twists. That is,  $N = \mathcal{D}(\mathcal{M}(\Gamma)) - L$ .*

*Proof.* Let  $N$  denote the manifold obtained by the construction. There are three things we need to show: the construction gives a submanifold of  $\mathcal{D}(\mathcal{M}(\Gamma))$ , the result is homeomorphic to a fully augmented link complement in  $\mathcal{D}(\mathcal{M}(\Gamma))$ , and that it is a complete hyperbolic manifold of finite volume.

For ease of notation, we will denote  $\mathcal{M}(\Gamma)$  simply by  $\mathcal{M}$ . We start by showing that  $N$  is a submanifold of  $\mathcal{D}(\mathcal{M})$ . The definition of a scooped manifold gives a natural embedding of  $M_P$  and  $M'_P$  in  $\mathcal{D}(\mathcal{M})$  such that  $M_P \cap M'_P = \emptyset$ . Under this embedding the ideal vertices of  $M_P$  and  $M'_P$  are identified and lie on  $\Sigma = \partial\mathcal{M} = \partial\mathcal{M}'$  in  $\mathcal{D}(\mathcal{M})$ .

By Lemma 3.4, there is a collection of horoball neighbourhoods  $H_i$  with boundaries meeting the ideal vertices in Euclidean rectangles  $R_i$ . By shrinking the  $H_i$  if needed, we may assume that for each rectangle, the length of any side meeting a black triangle is  $1/h$ , for some fixed large  $h$ . Let  $\bar{M}_P$  denote the result of removing the horoballs  $H_i$  from  $M_P$ . Thus  $\bar{M}_P$  is a compact manifold with corners. Similarly form  $\bar{M}'_P$  by removing identically sized horoball neighbourhoods from  $M'_P$ .

Since the (black) truncated side lengths of  $M_P$  are identical, we can glue truncated black triangles in  $\bar{M}_P$  to their pair in  $\bar{M}'_P$  by hyperbolic isometry, and similarly

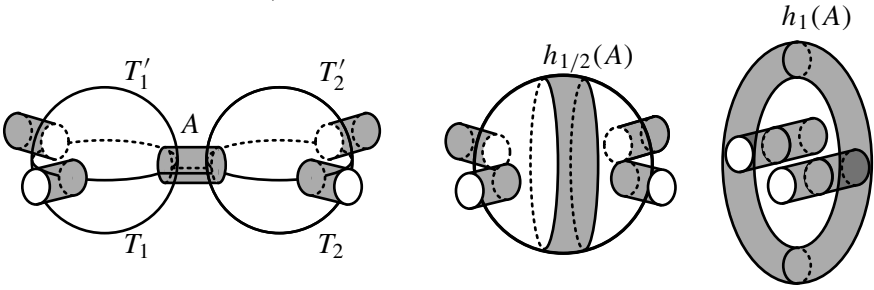

**Figure 6.** The result of gluing the white faces in  $\bar{M}_P$  and  $\bar{M}'_P$  is shown on the left, with cylinders formed from truncated ideal vertices shown in grey (note that faces shown in white are black faces in  $\bar{M}_P$  and  $\bar{M}'_P$ ). From the second to third image we identify the black faces (shown as white). We see that if the cylinder came from a ideal vertex between two paired black triangles then the gluing corresponds to a crossing circle.

for  $\bar{M}'_P$ . We may similarly glue truncated white faces in  $\bar{M}_P$  to those in  $\bar{M}'_P$  by isometry, because we will be truncating an identical amount in  $M_P$  and its reflection.

Let  $F \subset \partial\bar{M}_P$  be a truncated white face. Then there exists a projection  $p: F \rightarrow \Sigma$ . Similarly, the corresponding truncated white face  $F' \subset \partial\bar{M}'_P$  has an analogous projection  $p': F' \rightarrow \Sigma$  such that  $p(F) = p'(F')$ . Both of these projections can be extended to isotopies of  $\bar{M}_P$  and  $\bar{M}'_P$  in  $\mathcal{D}(\mathcal{M})$ . Since all such maps, for all white faces, correspond to isotopies, the manifold resulting from gluing the white faces is a submanifold of  $\mathcal{D}(\mathcal{M})$ .

Next we look at gluing pairs of truncated black triangles. Let  $T_1$  and  $T_2$  be two truncated black triangles in  $\partial\bar{M}_P$  that are paired by the dimer on  $P$  across a vertex  $v$ , and let  $R_v$  be the rectangle which truncates  $v$ . Similarly let  $T'_1$  and  $T'_2$  be the corresponding truncated triangles in  $\partial\bar{M}'_P$  with  $R'_v$  the rectangle meeting them. After identifying the white faces, the nontruncated edges of  $T_1$  and  $T'_1$  will be identified, and similarly for  $T_2$  and  $T'_2$ . Then after gluing white faces,  $T_1 \cup T'_1$  and  $T_2 \cup T'_2$  will correspond to a pair of spheres with three open disks removed. They are joined together via  $R_v$  and  $R'_v$ : after we identify the white faces, the white edges of  $R_v$  and  $R'_v$  have been identified, forming a cylinder  $A$ . The black edges on the ends of this cylinder form one of the boundary components of both spheres  $T_1 \cup T'_1, T_2 \cup T'_2$ . See Figure 6.

We can then perform an isotopy expanding  $A$  so that  $T_1 \cup T'_1$  and  $T_2 \cup T'_2$  and  $A$  lie on a sphere  $S$  with  $A$  forming a closed neighbourhood of a north-south great circle for  $S$ . We continue the isotopy, identifying  $T_1 \cup T'_1$  to  $T_2 \cup T'_2$  across a ball bounded by this sphere, as shown in Figure 6. This corresponds to identifying  $T_1$  with  $T_2$ , and  $T'_1$  with  $T'_2$ . Observe that the result after identification is a disk  $D$  with

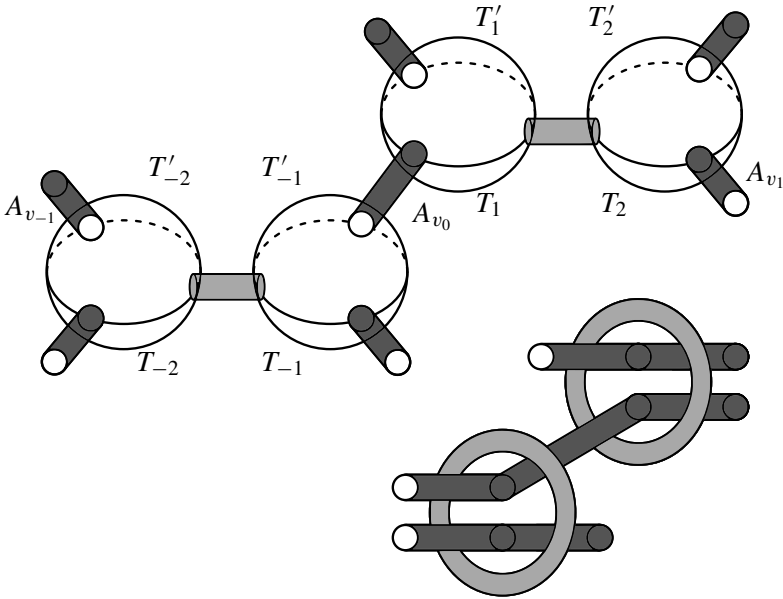

**Figure 7.** First image shows the result after gluing truncated white faces (the truncated black triangles  $T_i$  are shown as white). The light grey cylinders correspond to the cylinders associated with the paired vertices  $v_{-1}$  and  $v_1$ . The dark grey cylinders do not pair black triangles together. The second image shows the result after gluing black triangles together.

two open disks removed. The annulus  $A$  has two boundary components identified to form a torus. This torus meets the black geodesic surface of  $D$  on its outside boundary, corresponding to a longitude. The other two boundary components of  $D$  correspond to two cylinders obtained by gluing vertices which do not pair black faces in the dimer. See Figure 6. Thus the ideal vertices that pair black triangles correspond to crossing circles.

Each of these steps is by isotopy in  $\mathcal{D}(\mathcal{M})$ . We do this for each pair of truncated black triangles on  $\partial\bar{M}_P$ . Hence the gluing of  $\bar{M}_P$  and  $\bar{M}'_P$  gives a submanifold of  $\mathcal{D}(\mathcal{M})$ . Finally, note that the gluing of  $M_P$  now embeds as a submanifold of  $\mathcal{D}(\mathcal{M})$  because it is homeomorphic to the gluing of the truncated  $\bar{M}_P$  without its boundary.

We still need to show that  $N$  is homeomorphic to a link complement in  $\mathcal{D}(\mathcal{M})$ . We have seen that ideal vertices meeting paired black faces will correspond to crossing circles in  $\mathcal{D}(\mathcal{M})$ . Now let  $v_0 \in V$  be a vertex which does not pair two black faces. Let  $R_{v_0}$  be the rectangle on  $\partial\bar{M}_P$  associated with  $v_0$ . Then  $R_{v_0}$  meets two truncated black triangles  $T_{-1}, T_1 \subset \partial\bar{M}_P$ . The triangle  $T_1$  is paired to another truncated black triangle  $T_2$  as specified by the dimer on  $P$ , across a vertex  $v_1$ . Similarly  $T_{-1}$  is

paired to another truncated black triangle  $T_{-2}$ , across a vertex  $p_{-1}$ . See [Figure 7](#). After gluing  $T_1$  and  $T_2$ , one of the black edges of  $R_{v_0}$  will be glued to a black edge of another rectangle  $R_{v_1}$  that intersects  $T_2$ , while the other black edge of  $R_{v_0}$ , will be glued to a black edge of a rectangle  $R_{v_{-1}}$  that intersects  $T_{-2}$ .

After gluing white faces, the pairs  $R_{v_k}$  and  $R'_{v_k}$ , for  $k \in \{-1, 0, 1\}$ , are glued along their white edges and form cylinders, which we denote  $A_k$  for  $k \in \{-1, 0, 1\}$ . After gluing the black faces,  $A_{-1}$  will be glued to one end of  $A_0$  while  $A_1$  will be glued to the other end. Let  $A$  be the result of gluing these three cylinders together. The cylinder  $A$  then passes through the two crossing circles associated with  $v_{-1}$  and  $v_1$ . This is shown in the second image in [Figure 7](#).

Every cylinder associated with a vertex  $v \in V$  that does not pair black faces has its ends glued to other cylinders. It follows that the collection of all such cylinders forms a collection of tori. If  $T$  is such a torus then  $T$  has a Euclidean structure given by gluing a chain of rectangles  $R_{v_0}, R_{v_1}, \dots, R_{v_k}$  together; these are glued along their black sides. This chain is then glued to the corresponding chain  $R'_{v_0}, R'_{v_1}, \dots, R'_{v_k}$  via their white sides. Note that the white sides of  $R_{v_i}$  and  $R'_{v_i}$ , for  $i \in \{0, 1, \dots, k\}$  lie on a geodesic surface formed from gluing the white faces. In this sense each of these tori lies on the white surface formed from the gluing of white faces, which is homeomorphic to  $\partial\mathcal{M}$ . Thus the glued manifold  $N$  is homeomorphic to the complement of a fully augmented link on a surface without half twists. The ideal boundary components that correspond to vertices in  $V$  pairing black faces are crossing circles, while the other vertices make up portions of the link components in the surface.

Finally we show that the resulting gluing has a complete hyperbolic structure. The fact that it has a hyperbolic structure follows from the fact that the gluing of faces is by isometry, and the faces meet at dihedral angle  $\pi/2$ , with four such angles identified under the gluing. Thus the sum of dihedral angles around any edge is  $2\pi$ ; see for example [\[40, Theorem 4.7\]](#).

To show that the structure is complete, we need to show that each of the ideal torus boundary components has an induced Euclidean structure; see for example [\[40, Theorem 4.10\]](#). We have seen that each torus boundary component is tiled by rectangles  $R_v$  coming from ideal vertices of the scooped manifold. The cusp structure is induced by the gluing of the Euclidean rectangles. Since they are rectangles, with angles  $\pi/2$ , and matching side lengths, they do indeed give the cusp a Euclidean structure.

Finally  $N$  is finite volume since  $M_P$  and  $M_{P'}$  have finite volume, by [Lemma 3.5](#). Alternately since we have a complete hyperbolic 3-manifold with ideal boundary consisting of tori it must be finite volume; see for example [\[40, Theorem 5.24\]](#).  $\square$

One nice property of the links formed from this identification is that we can use the dimer on the nerve to draw the link directly from the circle packing.

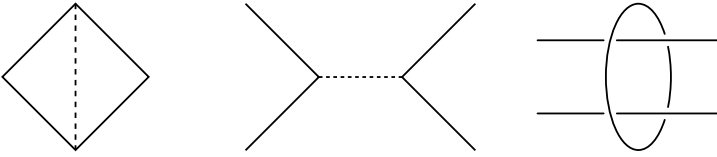

**Figure 8.** Left: shows part of the nerve of  $P$  in which the edge coloured by the dimer is shown dashed. Middle: shows corresponding part of the nerve of  $P^*$ . Right: replace the dashed line with a crossing circle to draw the link.

**Corollary 3.12.** *The link formed from the gluing of  $M_P$  and  $M'_P$  can be drawn directly from the nerve of  $P^*$  on  $\Sigma$ .*

*Proof.* The nerve of  $P^*$  is 3-valent with a coloured edge given by the dimer on  $P$ . Each coloured edge in  $P^*$  corresponds to an ideal vertex shared by two paired black faces on  $\partial M_P$ . Such a vertex corresponds to a crossing circle. The two edges that are not coloured correspond to arcs in  $\Sigma$ . So for each coloured edge in  $P^*$ , draw a crossing circle, with arcs between crossing circles the noncoloured edges of  $P^*$ . [Figure 8](#) shows the local picture. □

### 3C. Adding half-twists.

**Lemma 3.13.** *Let  $C$  be a crossing circle of a fully augmented link  $L$  embedded in a closed 3-manifold  $M$  such that  $M - L$  is hyperbolic. Then for the link  $L'$  obtained by adding a half twist at  $C$ , the complement  $M - L'$  is also hyperbolic.*

*Proof.* This follows from Adams [2]. The crossing circle  $C$  bounds a 3-punctured sphere, which is isotopic to a totally geodesic surface. Cut along this surface and reglue via the homeomorphism of the 3-punctured sphere that keeps the puncture associated with  $C$  fixed and swaps the other two punctures. Since there is only one complete hyperbolic structure on a 3-punctured sphere, this is an isometry, hence gives a hyperbolic manifold with the desired properties. □

If we look back at the original gluing in [Theorem 3.11](#), adding a half twist at a crossing circle corresponds to changing the gluing of the black faces in  $\partial M_P$  and  $\partial M'_P$ . Instead of gluing a black triangle to its pair on the same half, it will be glued to the pair in the opposite half.

**Lemma 3.14.** *Let  $N$  be a manifold formed in the manner of [Construction 3.10](#), which are complements of fully augmented links without half-twists by [Theorem 3.11](#). Adding a half twist at a crossing circle corresponds to gluing a black triangle  $T_1$  of  $M_P$  with the triangle  $T'_2$  on  $M'_P$ , paired to the reflection  $T'_1$  of  $T_1$  by the dimer.*

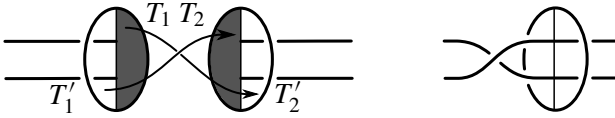

**Figure 9.** Shows how gluing black triangles in  $\partial M_P$  to the paired triangle in  $\partial M'_P$  corresponds to adding a half twist.

*Proof.* A half-twist is added by rotating the half  $T_1 \cup T'_1$  of Figure 6, middle, by  $180^\circ$  before gluing. See Figure 9. This glues  $T_1$  with  $T'_2$ , and  $T'_1$  with  $T_2$ , via an orientation reversing isometry.  $\square$

**Lemma 3.15.** *Let  $M = \mathbb{H}^3/\Gamma$  be a convex cocompact hyperbolic 3-manifold, and let  $N$  be the complement of a fully augmented link in  $\mathcal{D}(M)$  constructed in Construction 3.10. Then we may form a new hyperbolic 3-manifold  $N'$  such that  $N'$  is the complement of a fully augmented link  $L'$  on  $\partial M \subset \mathcal{D}(M)$ , where  $L'$  has only one component that is not a crossing circle on each component of  $\partial M$ , and  $L'$  is formed from  $L$  by adding half twists at some of the crossing circles of  $L$ .*

*Proof.* Let  $K_1, \dots, K_n$  be the link components of  $L$  that are not crossing circles. If  $n \geq 2$ , then since the diagram graph of  $L$  is connected, there must be some crossing circle  $C$  such that there are two distinct components  $K_j$  and  $K_k$  passing through  $C$ . Let  $L_C$  denote the link formed by adding a half twist at  $C$  to  $L$ . Adding the half twist at  $C$  concatenates  $K_j$  and  $K_k$ , reducing the number of components by one. Repeat until there is only one component that is not a crossing circle on each component of  $\partial M$ .  $\square$

**3D. Showing geometric convergence.** Now we show how we can use the construction of the previous section to construct sequences of link complements which converge geometrically to  $M$ .

**Lemma 3.16.** *Let  $M = \mathbb{H}^3/\Gamma$  be a convex-cocompact hyperbolic 3-manifold homeomorphic to the interior of a compact 3-manifold  $\bar{M}$  and let  $\epsilon > 0$  and  $R > 0$ .*

*Then there exists a finite volume hyperbolic 3-manifold with framed basepoint  $(M_{\epsilon,R}, p_{\epsilon,R})$  that is a link complement in  $\mathcal{D}(\bar{M})$  such that  $(M_{\epsilon,R}, p_{\epsilon,R})$  is  $(\epsilon, R)$ -close to  $(M, p)$ , where  $p$  is the framed basepoint on  $M = \mathbb{H}^3/\Gamma$  induced by  $O$  in  $\mathbb{H}^3$ .*

*Proof.* By Lemma 3.2, we can find an  $e^\delta$ -quasiconformal homeomorphism  $\phi$  fixing  $0, 1, \infty$  conjugating  $\Gamma$  to  $\Gamma_\delta$  such that the associated convex-cocompact manifold  $N_\delta = \mathbb{H}^3/\Gamma_\delta$  admits a circle packing  $P_\delta$  on its conformal boundary, and the metric ball  $B(0, R)/\Gamma_\delta$  is completely contained in the corresponding scooped manifold  $(N_\delta)_{P_\delta}$ . Further, we may take  $N_\delta, P_\delta$  as above so that the nerve of  $P_\delta$  admits a dimer. By Corollary 2.11,  $N_\delta$  is  $(\epsilon, R)$ -close to  $M$  for  $\delta$  sufficiently small,

if both  $M = \mathbb{H}^3/\Gamma$  and  $N_\delta = \mathbb{H}^3/\Gamma_\delta$  are endowed with the framed basepoint  $p, p_\delta$  induced from  $O$  in  $\mathbb{H}^3$ .

Let  $M_{\epsilon,R}$  be a link complement in  $\mathcal{D}(\bar{M})$  formed from gluing two copies of  $(N_\delta)_{P_\delta}$  in the manner specified in [Theorem 3.11](#) for  $\delta = \delta(\epsilon, R)$  small as above. Since  $(N_\delta)_{P_\delta}$  isometrically embeds in  $M_{\epsilon,R}$ , we have (denoting the image of  $p_\delta$  by  $p_{\epsilon,R}$ ) that  $(M_{\epsilon,R}, p_{\epsilon,R})$  is  $(\epsilon, R)$ -close to  $(M, p)$ .  $\square$

As an immediate consequence we have:

**Corollary 3.17.** *The links of [Lemma 3.16](#) converge geometrically to  $M$ .*  $\square$

We now turn the link complements of [Corollary 3.17](#) into knot complements.

**Theorem 3.18.** *Let  $M$  be a convex cocompact hyperbolic 3-manifold that is the interior of a compact 3-manifold  $\bar{M}$ . Then there exists a sequence of finite volume hyperbolic 3-manifolds  $M_n$  that are link complements in  $\mathcal{D}(\bar{M})$ , with one link component per boundary component of  $\bar{M}$ , such that  $M_n$  converges geometrically to  $M$ .*

*In particular, if  $\bar{M}$  has a single boundary component, then  $M$  is the geometric limit of a sequence of knot complements.*

*Proof.* By taking  $(\epsilon, R) = (1/n, n)$  in [Lemma 3.16](#), we find a sequence of fully augmented links on a surface in  $\mathcal{D}(\bar{M})$  which contain  $(n+1)/n$ -bilipschitz images  $B(p, n) \subset M$ . By [Lemma 3.15](#), by adding half twists at some of the crossing circles we obtain a fully augmented link on the surface  $\partial\bar{M} \subset \mathcal{D}(\bar{M})$  that has a single component that is not a crossing circle on each component of  $\partial\bar{M}$ . [Lemma 3.14](#) shows that adding a half twist corresponds to changing the gluing of black faces, which does not affect the embedding  $B(p, n)$  of [Lemma 3.16](#). Thus we obtain a sequence  $L_n$  of complements of fully augmented links in  $\mathcal{D}(\bar{M})$  converging geometrically to  $(M, p)$ , for suitable framed basepoints, such that for each component of  $\partial\bar{M}$  embedded in  $\mathcal{D}(\bar{M})$ , only one link component is not a crossing circle.

Let  $s \in \mathbb{Z}$  be a positive integer. Observe that  $1/s$  Dehn filling on a crossing circle  $C$  of  $L_n$  inserts  $2s$  crossings into the twist region encircled by  $C$  and removes the link component  $C$ . We do this for all crossing circles. Let  $i_n$  be the number of crossing circles in  $L_n$ , and let  $s_k^1, \dots, s_k^{i_n}$  denote sequences of positive integers approaching infinity as  $k \rightarrow \infty$ . Thurston’s hyperbolic Dehn surgery theorem tells us that for fixed  $n$  the sequence of manifolds  $M_n(1/s_k^1, \dots, 1/s_k^{i_n})$  converges geometrically to  $M_n$  [[44](#)]. Taking a diagonal sequence, we obtain a sequence of knot complements in  $\mathcal{D}(\bar{M})$  converging geometrically to  $M$ .  $\square$

**3E. Effective Dehn filling.** We promised in the introduction a constructive method to build knot Dehn complements converging to  $M$ . [Theorem 3.18](#) uses Thurston’s hyperbolic Dehn surgery theorem to imply that such knots must exist, however that theorem is not constructive. In this section, we explain how the proof can be

modified to use cone deformation techniques to explicitly construct knots with the desired properties.

To do so, we need to know more about the cusp shapes and normalised lengths of Dehn filling slopes on the link complements  $M_{\epsilon, R}$  of [Lemma 3.16](#).

**Lemma 3.19.** *In the hyperbolic structure on the fully augmented link complement  $M_{\epsilon, R}$  of [Lemma 3.16](#), each cusp corresponding to a crossing circle is tiled by two identical Euclidean rectangles. Each rectangle has a pair of opposite sides coming from the intersection of a horospherical cusp torus with black sides, and a pair coming from an intersection with white sides. The slope  $1/n$  on this cusp is isotopic to a curve as follows:*

- *If the crossing circle does not meet a half-twist, the slope is given by one step along a white side, plus or minus  $2n$  steps along black sides.*
- *If the crossing circle meets a half-twist, then the meridian is sheared. Thus the slope is given by one step along a white side, plus or minus  $(2n + 1)$  steps along black sides.*

*In either case, if  $c$  is the number of crossings added to this twist region of the diagram after Dehn filling, then the slope is given by one step along a white side plus or minus  $c$  steps along black sides.*

*Proof.* The proof is completely analogous to a similar result for crossing circle cusps in the classical setting of fully augmented links in the 3-sphere; see [\[39, Proposition 3.2\]](#) or [\[15, Lemma 2.6, Theorem 2.7\]](#). We walk through it in this setting.

By [Lemma 3.4](#), each crossing circle is tiled by rectangles, each with two opposite black sides, coming from intersections of black triangles with a horospherical torus about the cusp, and two opposite white sides, coming from intersections of white faces with a horospherical torus. Tracing through the gluing construction of [3.10](#), with reference to [Figure 6](#), the crossing circle cusps are built by first gluing one rectangle from the original scooped manifold  $M_P$  to an identical copy from  $M'_P$ , via a reflection in a white side. When there is no half-twist, the black sides of each of these rectangles are then glued together. A longitude runs over the two black sides, meeting two white sides along the way. A meridian runs over exactly one white side, meeting exactly one black side transversely along the way.

When a half-twist is added, the longitude still runs over two black sides, but a meridian is obtained by taking a step along a white side plus or minus a step along a black side, depending on the direction of twist. We may assume that the direction of twist matches the sign of  $n$ , otherwise apply a homeomorphism giving a half-twist in the opposite direction, and reduce  $|n|$  by two. This introduces shearing to the meridian.



The slope  $1/n$  runs over one meridian and  $n$  longitudes. In the case of no half-twists, this is one step along a white side, plus  $2n$  steps along black sides. This adds  $|2n| = c$  crossings to the twist region.

When there is a half-twist, the slope  $1/n$  still runs over one meridian plus  $n$  longitudes, but now this is given by one step along a white side plus or minus one step along a black side (with sign matching sign of  $n$ ), plus  $2n$  additional steps along black sides. Again there are  $c = |2n + 1|$  steps along black sides.  $\square$

The *normalised length* of a slope  $s$  on a cusp torus  $T$  is the length of a geodesic representative of the slope in the Euclidean metric on  $T$ , divided by the area of the torus:

$$L(s) = \text{len}(s) / \sqrt{\text{area}(T)}.$$

Observe that the normalised length is independent of scale, thus it is an invariant of the cusp rather than the choice of horospherical neighbourhood of the cusp.

The following result, for fully augmented links in  $\mathcal{D}(M)$ , is analogous to a calculation for fully augmented links in  $S^3$  found in [37]:

**Lemma 3.20.** *Let  $c$  be the number of crossings added by Dehn filling at a crossing circle. Then the corresponding slope of the Dehn filling has normalised length at least  $\sqrt{c}$ .*

*Proof.* From Lemma 3.19, we know that the two rectangles in the cusp tiling of the crossing circle are identical, hence each white side has length  $w$  and each black side length  $b$ . The area of the cusp, with or without half-twists, is given by  $2bw$ . Thus by Lemma 3.19, the normalised length of the slope  $1/n$  is given by

$$L = \frac{\sqrt{w^2 + c^2b^2}}{\sqrt{2bw}} = \sqrt{\frac{w}{2b} + \frac{c^2b}{2w}}.$$

This is minimised when  $w/2b$  equals  $c/2$ , and the minimum value is  $\sqrt{c}$ .  $\square$

**Lemma 3.21.** *Given  $M, \epsilon > 0, R > 0$ , and  $M_{\epsilon,R}$  as in Lemma 3.16, let  $\delta > 0$  be such that  $B(p, R)$  lies in the  $\delta/(1 + \epsilon)$ -thick part of  $M$ . Let  $n$  denote the number of crossing circles of the fully augmented link in  $M_{\epsilon,R}$ . If after Dehn filling the crossing circles, the number of crossings added to each twist region is at least*

$$n \cdot \max \left\{ \frac{107.6}{\delta^2} + 14.41, \frac{45.20}{\delta^{5/2} \log(1 + \epsilon)} + 14.41 \right\},$$

*then the inclusion map taking  $B(p_{\epsilon,R}, R)$  in  $M_{\epsilon,R}$  into the complement of the resulting knot in  $\mathcal{D}(M)$  is  $(1 + \epsilon)$ -bilipschitz. It follows that the knot complement contains a set that is  $(1 + \epsilon)^2$ -bilipschitz to  $B(p, R)$  in the original  $M$ .*

*Proof.* By Lemma 3.16, if  $B(p, R)$  lies in the  $\delta/(1 + \epsilon)$  thick part of  $M$ , then  $B(p_{\epsilon,R}, R)$  lies in the  $\delta$  thick part of  $M_{\epsilon,R}$  and is  $(1 + \epsilon)$  bilipschitz to  $B(p, R)$ .

Let  $L^2$  be given by

$$\frac{1}{L^2} = \sum_{i=1}^n \frac{1}{L_i^2},$$

where  $L_i$  is the normalised length of the Dehn filling slope on the  $i$ -th crossing circle cusp. In [17, Corollary 8.16], it is shown that if  $L^2$  is at least the maximum given above, then the inclusion map on any submanifold of the  $\delta$ -thick part is  $(1 + \epsilon)$ -bilipschitz.

Let  $C$  be the minimal number of crossings added to any twist region. By Lemma 3.20,  $1/L_i^2 \leq 1/C$ , so  $1/L^2 \leq n/C$ , or  $L^2 \geq C/n$ . Thus if  $C/n$  is at least the maximum in the formula above, we may apply the corollary from [17] to  $B(p_{\epsilon,R}, R)$ .  $\square$

#### 4. Reducing geometrically finite to convex cocompact

The previous sections constructed link complements that converge to convex cocompact hyperbolic structures. In the case of a single topological end, the limiting manifolds are all knot complements. The construction can be extended almost immediately to geometrically finite manifolds of infinite volume. However, now in the case that the manifold has a single topological end, if that end contains a rank-1 cusp, the immediate extension produces link complements rather than knot complements. Indeed, in the presence of rank one and rank two cusps our construction above leads to several cusp boundary components and thus to a complementary link with multiple components. Instead we will show that a geometrically finite manifold  $M$  can be approximated geometrically by convex cocompact manifolds. Combining this with the previous results, it follows that  $M$  can also be approximated geometrically by knot complements if it is of infinite volume with a single topological end.

For rank two cusps, a version of Thurston's hyperbolic Dehn surgery theorem for geometrically finite hyperbolic manifolds shows that a geometrically finite manifold is the geometric limit of geometrically finite manifolds without rank two cusps; see, for example, work of Brock and Bromberg [10]. However in our setting, i.e., a 3-manifold with one end, rank one cusps are more problematic. Here we show that for any geometrically finite hyperbolic manifold  $M$ , there is sequence of geometrically finite hyperbolic manifolds  $M_j$  without rank one cusps converging to  $M$ . Moreover the sequence can be chosen such that the maps establishing this convergence are global diffeomorphisms. In particular  $M_j$  is diffeomorphic to  $M$  for each  $j$ .

Results such as this go back to work of Jørgensen, and is presumably implicit in the construction of Earle–Marden geometric coordinates (cf. [29] and the appendix of [21]); compare also Marden [30, exercises 4-24 and 5-3]. We include the result and a proof for completeness.

**Theorem 4.1.** *Let  $M$  be a geometrically finite hyperbolic manifold. Then there exists a sequence of geometrically finite hyperbolic manifolds  $M_j$  without any rank one cusps and diffeomorphisms  $M \rightarrow M_j$  establishing that the  $M_j$  converge geometrically to  $M$ . The  $M_j$  are explicitly constructed starting from  $M$  and there are effective bounds for the convergence.*

To prove [Theorem 4.1](#), we first need to set up some notation. Fix a framed basepoint on  $p$  on  $M$ . Then  $(M, p)$  corresponds to a Kleinian group  $\Gamma$  such that  $(M, p) = (\mathbb{H}^3 / \Gamma, O)$ . We will first construct Kleinian groups  $\Gamma_{r(j)n(j)}$  corresponding to suitable hyperbolic 3-manifolds with framed basepoints  $(M_j, p_j)$  that converge to  $\Gamma$  in the Chabauty topology (and thus  $(M_j, p_j)$  converges geometrically to  $(M, p)$ ). When viewed as perturbations of  $\Gamma$ , the Kleinian groups  $\Gamma_{r(j)n(j)}$  also converge algebraically to  $\Gamma$  and the desired convergence properties will follow.

Consider a fixed rank one cusp of  $M$ , generated by  $\eta_1$ . Up to conjugation, we may assume  $\eta_1$  corresponds to  $z \mapsto z + 1$ . For  $r_1 > 0$ , let  $\gamma_{r_1}$  correspond to  $z \mapsto z + r_1\sqrt{-1}$ . Add  $\gamma_1 := \gamma_{r_1}$  to  $\Gamma$  as a generator to obtain  $\Gamma_{r_1}$ , with presentation  $\langle G, \gamma_1 \mid R, [\gamma_1, \eta_1] = 1 \rangle$ , where  $\langle G \mid R \rangle$  is a presentation of  $\Gamma$ .

**Lemma 4.2.** *For  $r_1$  sufficiently large,  $\Gamma_{r_1}$  is a discrete group and an HNN extension of  $\Gamma$ .*

*Proof.* This will be a consequence of the second Klein–Maskit combination theorem; we use the version as stated in Abikoff and Maskit [\[1\]](#), for a proof see Maskit [\[32, VII E.5\]](#).

Let  $H$  be a subgroup of  $\Gamma$ . Recall that a subset  $B \subset \mathbb{C} \cup \{\infty\}$  is precisely invariant under  $H$  in  $\Gamma$  if (1) for all  $h \in H$ ,  $h(B) = B$  and (2) for all  $\gamma \in \Gamma \setminus H$ ,  $\gamma(B) \cap B = \emptyset$ . In our setting, consider the round discs  $D_{\pm} := D_{\pm}(r_1) = \{z \in \mathbb{C} \mid \pm \operatorname{Im}(z) > r_1/2\}$  in  $\mathbb{C} \cup \{\infty\}$ . We claim that for  $r_1$  sufficiently large, the  $\Gamma$ -orbits of  $D_+$  and  $D_-$  are disjoint and that  $D_{\pm}$  are both precisely invariant under the subgroup  $H = \langle \eta_1 \rangle$  of  $\Gamma$ .

This follows, for example, from work of Bowditch [\[9\]](#), specifically his result that geometrically finite is equivalent to his definition GF1, which we now recall. By Bowditch’s definition GF1, the fundamental domain of a geometrically finite hyperbolic manifold is realised as the union of a compact set and a finite number of disjoint *standard* cusp regions (see [\[9, Proposition 4.4\]](#) for a proof that geometrically finite hyperbolic manifolds admit standard cusp regions). A standard cusp for  $\eta_1$  is modelled as follows: Consider the universal cover  $\mathbb{H}^3$  of  $M$ , in the upper half-space model, with boundary  $\mathbb{C} \cup \{\infty\}$ . The parabolic  $\eta_1$ , taking  $z$  to  $z + 1$ , acts as translation on horospheres about infinity, taking vertical planes in  $\mathbb{H}^3$  with boundary of the form  $\{x \in \mathbb{C} \mid \operatorname{Re}(x) = R\}$ , for fixed  $R \in \mathbb{R}$ , to vertical planes in  $\mathbb{H}^3$  with boundary  $\{x \in \mathbb{C} \mid \operatorname{Re}(x) = R + 1\}$ . There is an  $\eta_1$ -invariant subspace  $P \subset \mathbb{C}$  with  $P/\langle \eta_1 \rangle$  compact; in the 3-dimensional rank-1 case at hand,  $P = P(r)$  can be chosen to be an infinite strip bounded by two lines  $L(\pm r/2) = \{x \in \mathbb{C} \mid \operatorname{Im}(x) = \pm r/2\}$ .

See [9, Figure 3a]. Bowditch's definition of a standard cusp implies that for some height  $h > 0$ , the region

$$C = C(P(r), h) = \{x \in \mathbb{H}^3 \mid d_{\text{euc}}(x, P(r)) \geq h\}$$

must satisfy  $\gamma(C) \cap C = \emptyset$  for all  $\gamma \in \Gamma \setminus H$ . For  $r_1$  large,  $D_{\pm} \subset C$ , and therefore  $\gamma(D_+ \cup D_-) \cap (D_+ \cup D_-) = \emptyset$  for  $\gamma \in \Gamma \setminus H$ . Combining this with the fact that  $H$  preserves both  $D_{\pm}$  separately, it follows that the  $\Gamma$ -orbits of  $D_{\pm}$  are disjoint and that both  $D_{\pm}$  are precisely invariant under  $H$  in  $\Gamma$ .

Now consider  $f = \gamma_{r_1}$  defined as above. Note that since  $\gamma_{r_1}$  and  $\eta_1$  commute,  $fHf^{-1} = H < \Gamma$ . The observations above on Bowditch's definition GF1 imply the following three conditions required for the second Klein–Maskit combination theorem:

- (1)  $D_+$  is precisely invariant for  $H$  in  $\Gamma$ ,
- (2)  $C - \gamma_{r_1}(\bar{D}_+) = D_-$  is precisely invariant for  $fHf^{-1} = H$  in  $\Gamma$ ,
- (3)  $\gamma(D_+) \cap D_- = \emptyset$  for all  $\gamma \in \Gamma$ .

Then by the second Klein–Maskit combination theorem,  $\Gamma_{r_1}$  is a discrete group and an HNN extension of  $\Gamma$ .  $\square$

*Proof of Theorem 4.1.* Apply Lemma 4.2 iteratively to all rank one cusps of  $\Gamma$ ; we obtain a Kleinian group  $\Gamma_r$ ,  $r = (r_1, \dots, r_k)$ , for  $r_{i+1} \gg r_i$ ,  $i = 1, \dots, k-1$ . It has  $k$  rank two cusps corresponding to the  $k$  rank one cusps of  $M$ , and additionally any rank two cusps inherited from  $\Gamma$ , but no rank one cusps. It has a presentation of the form

$$\Gamma_r = \langle G, \gamma_1, \dots, \gamma_k \mid R, [\gamma_i, \eta_i] = 1, \forall i = 1, \dots, k \rangle.$$

As  $r_1 = \min_i r_i$  tends to infinity, these groups converge geometrically to  $\Gamma$ .

Now perform  $(1, n)$ -Dehn surgery on the  $k$  new rank two cusps of  $\Gamma_r$ , where the meridian of the  $i$ -th cusp (filled for  $n = 0$ ) corresponds to the new generator  $\gamma_{r_i}$ . For  $n$  sufficiently large, this yields Kleinian groups  $\Gamma_{rn}$  with presentations

$$\Gamma_{rn} = \langle G, \gamma_1, \dots, \gamma_k \mid R, [\gamma_i, \eta_i] = 1, \gamma_i \eta_i^n = 1, \forall i = 1, \dots, k \rangle.$$

The groups  $\Gamma_{rn}$  are canonically isomorphic to  $\Gamma$ : There is a natural isomorphism  $m_{rn} : \Gamma \rightarrow \Gamma_{rn}$  whose inverse sends  $\gamma_i$  to  $\eta_i^{-n}$  for all  $i = 1, \dots, k$ .

Thus the  $\Gamma_{rn}$  are images of faithful, geometrically finite representations of  $\Gamma$ . Moreover, since the construction of  $\Gamma_{rn}$  is via Dehn surgery, for  $n$  large,  $m_{rn}(\theta)$  for  $\theta \in \Gamma$  is parabolic if and only if  $\theta$  is part of a rank two cusp of  $\Gamma$ . In particular, the elements  $m_{rn}(\eta_i)$  are hyperbolic and  $\Gamma_{rn}$  has no rank one cusps.

These representations converge algebraically to  $\Gamma$  as  $n \rightarrow \infty$ , since Dehn surgery is a perturbation of the identity in terms of representations of the group  $\Gamma_r$ , thus in particular in terms of the subgroups  $\Gamma \subset \Gamma_r$ . A suitable formulation of Dehn surgery,

due to Comar, can be found in [5, Theorem 10.1]. Moreover the Kleinian groups  $\Gamma_{r_n}$  converge geometrically (i.e., in the Chabauty topology) to  $\Gamma_r$  as  $n \rightarrow \infty$  [44]. Thus for each value of  $r_i$ , we may choose a sequence  $r_i(j)_{j \in \mathbb{N}}$  tending to infinity, and consider  $r(j) = (r_1(j), \dots, r_k(j))$  as above. Choosing  $n(j)$  sufficiently large, we find that the diagonal sequence of Kleinian groups  $\Gamma_{r(j)n(j)}$ , uniformizing the geometrically finite hyperbolic manifolds  $M_j$  without rank one cusps, converges both geometrically and algebraically to  $\Gamma$ , uniformizing  $M$ .

This implies that the limit  $M$  is diffeomorphic to  $M_j$  for  $j$  sufficiently large, as follows (compare [5, Lemma 3.6]): Indeed, the compact core of  $M$  embeds via its interpretation as geometric limit back into  $M_j$  for  $j$  large. This induces a map on fundamental groups  $\Gamma \rightarrow \Gamma_{r(j)n(j)}$ , which necessarily coincides with the isomorphism  $\Gamma \rightarrow \Gamma_{r(j)n(j)}$  establishing that  $\Gamma$  is the algebraic limit of  $\Gamma_{r(j)n(j)}$ . Thus the compact core of  $M$  embeds as a compact core into  $M_j$  for  $j$  large. By the uniqueness of compact cores and since a diffeomorphism of compact cores can be extended to a diffeomorphism of the ambient hyperbolic manifolds, the claimed result follows.

Finally we remark on the constructive nature of the proof. Observe that the process above is obtained by first, choosing a sufficiently large  $r_i$  at each rank one cusp to build manifolds with rank two cusps. Then perform high Dehn filling. The choice of  $r_1$  will depend heavily on  $M$ , but given a fundamental domain for  $M$ , these can be determined effectively. By our choice of the  $\gamma_{r_i}$ , the new rank two cusps of the manifold  $\mathbb{H}^3/\Gamma_r$  are rectangular. Thus the normalised length of the slopes  $1/n$  have length at least  $\sqrt{n}$ . Again applying cone deformation techniques, we may choose effective  $n$  sufficiently large to obtain constants required in the definition of geometric convergence, as in the proof of Lemma 3.21.  $\square$

**Corollary 4.3.** *Let  $M$  be a geometrically finite hyperbolic 3-manifold of infinite volume that is homeomorphic to the interior of a compact manifold  $\bar{M}$  with a single boundary component. Then one can construct an explicit sequence of finite volume hyperbolic manifolds that are knot complements in  $\mathcal{D}(\bar{M})$  such that  $M_n$  converges geometrically to  $M$ .*  $\square$

### Acknowledgement

This work was supported in part by grants from the Australian Research Council, particularly FT160100232, and DP210103136.

### References

- [1] W. Abikoff and B. Maskit, “Geometric decompositions of Kleinian groups”, *Amer. J. Math.* **99**:4 (1977), 687–697. [MR](#) [Zbl](#)

- [2] C. C. Adams, “Thrice-punctured spheres in hyperbolic 3-manifolds”, *Trans. Amer. Math. Soc.* **287**:2 (1985), 645–656. [MR](#) [Zbl](#)
- [3] C. Adams, M. Capovilla-Searle, D. Li, Q. Li, J. McErlean, A. Simons, N. Stewart, and X. Wang, “Generalized augmented cellular alternating links in thickened surfaces are hyperbolic”, 2020. [arXiv 2017.5406](#)
- [4] L. V. Ahlfors, “Finitely generated Kleinian groups”, *Amer. J. Math.* **86** (1964), 413–429. Correction in **87** (1965), 759. [MR](#) [Zbl](#)
- [5] J. W. Anderson, R. D. Canary, and D. McCullough, “The topology of deformation spaces of Kleinian groups”, *Ann. of Math. (2)* **152**:3 (2000), 693–741. [MR](#) [Zbl](#)
- [6] R. Benedetti and C. Petronio, *Lectures on hyperbolic geometry*, Springer, Berlin, 1992. [MR](#) [Zbl](#)
- [7] L. Bers, “Spaces of Kleinian groups”, pp. 9–34 in *Several Complex Variables, I* (Proc. Conf., Univ. of Maryland, College Park, Md., 1970), edited by J. Horváth, Springer, Berlin, 1970. [MR](#) [Zbl](#)
- [8] R. Blair, D. Futer, and M. Tomova, “Essential surfaces in highly twisted link complements”, *Algebr. Geom. Topol.* **15**:3 (2015), 1501–1523. [MR](#) [Zbl](#)
- [9] B. H. Bowditch, “Geometrical finiteness for hyperbolic groups”, *J. Funct. Anal.* **113**:2 (1993), 245–317. [MR](#) [Zbl](#)
- [10] J. F. Brock and K. W. Bromberg, “On the density of geometrically finite Kleinian groups”, *Acta Math.* **192**:1 (2004), 33–93. [MR](#) [Zbl](#)
- [11] R. Brooks, “On the deformation theory of classical Schottky groups”, *Duke Math. J.* **52**:4 (1985), 1009–1024. [MR](#) [Zbl](#)
- [12] R. Brooks, “Circle packings and co-compact extensions of Kleinian groups”, *Invent. Math.* **86**:3 (1986), 461–469. [MR](#) [Zbl](#)
- [13] R. D. Canary, D. B. A. Epstein, and P. L. Green, “Notes on notes of Thurston [MR0903850]”, pp. 1–115 in *Fundamentals of hyperbolic geometry: selected expositions*, edited by R. D. Canary et al., London Math. Soc. Lecture Note Ser. **328**, Cambridge Univ. Press, 2006. [MR](#)
- [14] B. O. Community, “Blender - a 3D modelling and rendering package”, 2021, available at <https://www.blender.org>.
- [15] D. Futer and J. S. Purcell, “Links with no exceptional surgeries”, *Comment. Math. Helv.* **82**:3 (2007), 629–664. [MR](#) [Zbl](#)
- [16] D. Futer, E. Kalfagianni, and J. S. Purcell, “Dehn filling, volume, and the Jones polynomial”, *J. Differential Geom.* **78**:3 (2008), 429–464. [MR](#) [Zbl](#)
- [17] D. Futer, J. S. Purcell, and S. Schleimer, “Effective bilipschitz bounds on drilling and filling”, *Geom. Topol.* **26**:3 (2022), 1077–1188. [MR](#) [Zbl](#)
- [18] F. W. Gehring, G. J. Martin, and B. P. Palka, *An introduction to the theory of higher-dimensional quasiconformal mappings*, Mathematical Surveys and Monographs **216**, American Mathematical Society, Providence, RI, 2017. [MR](#) [Zbl](#)
- [19] A. Hatcher, “Notes on basic 3-manifold topology”, notes, 2007, available at <https://tinyurl.com/Hatch3M>.
- [20] N. R. Hoffman and J. S. Purcell, “Geometry of planar surfaces and exceptional fillings”, *Bull. Lond. Math. Soc.* **49**:2 (2017), 185–201. [MR](#) [Zbl](#)

- [21] J. H. Hubbard and S. Koch, “An analytic construction of the Deligne–Mumford compactification of the moduli space of curves”, *J. Differential Geom.* **98**:2 (2014), 261–313. [MR](#) [Zbl](#)
- [22] E. Kalfagianni and C. R. S. Lee, “Crosscap numbers and the Jones polynomial”, *Adv. Math.* **286** (2016), 308–337. [MR](#) [Zbl](#)
- [23] M. Kapovich, *Hyperbolic manifolds and discrete groups*, Progress in Mathematics **183**, Birkhäuser, Boston, MA, 2001. [MR](#) [Zbl](#)
- [24] I. Kra, “On spaces of Kleinian groups”, *Comment. Math. Helv.* **47** (1972), 53–69. [MR](#) [Zbl](#)
- [25] A. Kwon, “Fully augmented links in the thickened torus”, 2020. [arXiv 2007.12773](#)
- [26] A. Kwon and Y. H. Tham, “Hyperbolicity of augmented links in the thickened torus”, *J. Knot Theory Ramifications* **31**:4 (2022), Paper No. 2250025, 17. [MR](#) [Zbl](#)
- [27] M. Lackenby, “The volume of hyperbolic alternating link complements”, *Proc. London Math. Soc.* (3) **88**:1 (2004), 204–224. With an appendix by Ian Agol and Dylan Thurston. [MR](#) [Zbl](#)
- [28] A. Marden, “The geometry of finitely generated kleinian groups”, *Ann. of Math.* (2) **99** (1974), 383–462. [MR](#) [Zbl](#)
- [29] A. Marden, “Geometric complex coordinates for Teichmüller space”, pp. 341–354 in *Mathematical aspects of string theory* (San Diego, Calif., 1986), edited by S.-T. Yau, Adv. Ser. Math. Phys. **1**, World Sci. Publishing, Singapore, 1987. [MR](#) [Zbl](#)
- [30] A. Marden, *Outer circles*, Cambridge University Press, 2007. [MR](#) [Zbl](#)
- [31] B. Maskit, “Self-maps on Kleinian groups”, *Amer. J. Math.* **93** (1971), 840–856. [MR](#) [Zbl](#)
- [32] B. Maskit, *Kleinian groups*, Grundle Math. Wissen. **287**, Springer, Berlin, 1988. [MR](#) [Zbl](#)
- [33] C. T. McMullen, *Renormalization and 3-manifolds which fiber over the circle*, Annals of Mathematics Studies **142**, Princeton University Press, 1996. [MR](#) [Zbl](#)
- [34] C. Millichap, “Mutations and short geodesics in hyperbolic 3-manifolds”, *Comm. Anal. Geom.* **25**:3 (2017), 625–683. [MR](#) [Zbl](#)
- [35] H. Namazi and J. Souto, “Non-realizability and ending laminations: proof of the density conjecture”, *Acta Math.* **209**:2 (2012), 323–395. [MR](#) [Zbl](#)
- [36] K. Ohshika, “Realising end invariants by limits of minimally parabolic, geometrically finite groups”, *Geom. Topol.* **15**:2 (2011), 827–890. [MR](#) [Zbl](#)
- [37] J. S. Purcell, “Volumes of highly twisted knots and links”, *Algebr. Geom. Topol.* **7** (2007), 93–108. [MR](#) [Zbl](#)
- [38] J. S. Purcell, “Cusp shapes under cone deformation”, *J. Differential Geom.* **80**:3 (2008), 453–500. [MR](#) [Zbl](#)
- [39] J. S. Purcell, “An introduction to fully augmented links”, pp. 205–220 in *Interactions between hyperbolic geometry, quantum topology and number theory*, edited by A. Champanerkar et al., Contemp. Math. **541**, Amer. Math. Soc., Providence, RI, 2011. [MR](#) [Zbl](#)
- [40] J. S. Purcell, *Hyperbolic knot theory*, Graduate Studies in Mathematics **209**, American Mathematical Society, Providence, RI, [2020] ©2020. [MR](#) [Zbl](#)
- [41] J. S. Purcell and J. Souto, “Geometric limits of knot complements”, *J. Topol.* **3**:4 (2010), 759–785. [MR](#) [Zbl](#)
- [42] K. Stephenson, *Introduction to circle packing*, Cambridge University Press, 2005. [MR](#) [Zbl](#)

- [43] J. E. Stewart, *Constructing knot complements with specified geometric limits*, master's thesis, Monash University, 2021, available at <https://tinyurl.com/StewartThesis>.
- [44] W. P. Thurston, *The geometry and topology of three-manifolds*, vol. 27, American Mathematical Society, 1979. [Zbl](#)

Received February 10, 2022. Revised May 1, 2023.

URS FUCHS  
RWTH AACHEN UNIVERSITY  
AACHEN  
GERMANY  
[fuchs@mathga.rwth-aachen.de](mailto:fuchs@mathga.rwth-aachen.de)

JESSICA S. PURCELL  
SCHOOL OF MATHEMATICS  
MONASH UNIVERSITY  
MELBOURNE  
AUSTRALIA  
[jessica.purcell@monash.edu](mailto:jessica.purcell@monash.edu)

JOHN STEWART  
SCHOOL OF MATHEMATICS AND STATISTICS  
THE UNIVERSITY OF MELBOURNE  
PARKVILLE  
AUSTRALIA  
[john.stewart@student.unimelb.edu.au](mailto:john.stewart@student.unimelb.edu.au)



# AN ISOPERIMETRIC INEQUALITY OF MINIMAL HYPERSURFACES IN SPHERES

FAGUI LI AND NIANG CHEN

**Let  $M^n$  be a closed immersed minimal hypersurface in the unit sphere  $\mathbb{S}^{n+1}$ . We establish a special isoperimetric inequality of  $M^n$ . As an application, if the scalar curvature of  $M^n$  is constant, then we get a uniform lower bound independent of  $M^n$  for the isoperimetric inequality. In addition, we obtain an inequality between Cheeger's isoperimetric constant and the volume of the nodal set of the height function.**

## 1. Introduction

The isoperimetric inequalities have always been an important subject in differential geometry and they are bridges of analysis and geometry. There are some elegant works on isoperimetric inequalities; see [2; 7; 14; 24].

Let  $x : M^n \looparrowright \mathbb{S}^{n+1} \subset \mathbb{R}^{n+2}$  be a closed immersed minimal hypersurface in the unit sphere and denote by  $\nu(x)$  a (local) unit normal vector field of  $M^n$ ,  $\nabla$  and  $\bar{\nabla}$  be the Levi–Civita connections on  $M^n$  and  $\mathbb{S}^{n+1}$ , respectively. Let  $A$  be the shape operator with respect to  $\nu$ , i.e.,  $A(X) = -\bar{\nabla}_X \nu$ . The squared length of the second fundamental form is  $S = \|A\|^2$ . For any unit vector  $a \in \mathbb{S}^{n+1}$ , the height functions are defined as

$$\varphi_a(x) = \langle x, a \rangle, \quad \psi_a(x) = \langle \nu, a \rangle.$$

These two functions are very basic and important. For instance, the well known Takahashi theorem [18] states that  $M^n$  is minimal if and only if there exists a constant  $\lambda$  such that  $\Delta\varphi_a = -\lambda\varphi_a$  for all  $a \in \mathbb{S}^{n+1}$ . Analogously, Ge and Li [10] gave a Takahashi-type theorem, i.e., an immersed hypersurface  $M^n$  in  $\mathbb{S}^{n+1}$  is minimal and has constant scalar curvature (CSC) if and only if  $\Delta\psi_a = \lambda\psi_a$  for some constant  $\lambda$  independent of  $a \in \mathbb{S}^{n+1}$ . This condition is linked to the famous

---

Li the corresponding author. F. G. Li is partially supported by NSFC (No. 12171037, 12271040) and China Postdoctoral Science Foundation (No. 2022M720261). N. Chen is partially supported by the start-up funding for research provided by Beijing Normal University (No. 310432120).

MSC2020: 53A10, 53C24, 53C42.

Keywords: isoperimetric inequality, minimal hypersurface, nodal set, Cheeger's isoperimetric constant.

Chern conjecture (see [4; 15; 22; 20; 23]), which states that a closed immersed minimal CSC hypersurface of  $\mathbb{S}^{n+1}$  is isoparametric.

Let  $\{|\varphi_a| \geq t\} = \{x \in M^n : |\varphi_a| \geq t\}$  and  $\{|\varphi_a| = t\} = \{x \in M^n : |\varphi_a| = t\}$ . In particular, due to  $\Delta\varphi_a = -n\varphi_a$  and  $a \in \mathbb{S}^{n+1}$ ,

$$\{\varphi_a = 0\} = \{x \in M^n : \varphi_a = 0\}$$

is the nodal set of the eigenfunction  $\varphi_a$ . Here, the zero set of the eigenfunction of an elliptic operator, and its complement are called the nodal set, and nodal domain, respectively. Suppose  $S_{\max} = \sup_{p \in M^n} S(p)$ ,

$$\theta_1 = \frac{\int_M S}{2n S_{\max} \text{Vol}(M^n)}, \quad \theta_2 = \frac{n}{4n^2 - 3n + 1} \frac{(\int_M S)^2}{\text{Vol}(M^n) \int_M S^2},$$

and

$$C_1 = \max\{\theta_1, \theta_2\}, \quad C_2 = \inf_{s \leq r \leq 1} \frac{2 + nr \ln((1-s^2)/(1-r^2))}{2 + n \ln((1-s^2)/(1-r^2))}.$$

We use Vol to represent the volume measure in this paper and the following special isoperimetric inequality is the main result.

**Theorem 1.1.** *Let  $M^n$  be a closed immersed, nontotally geodesic, minimal hypersurface in  $\mathbb{S}^{n+1}$ :*

(i) *For all  $0 \leq s < 1$  and  $a \in \mathbb{S}^{n+1}$ , the following inequality holds:*

$$\text{Vol}\{|\varphi_a| = s\} \geq C(n, s, S) \text{Vol}\{|\varphi_a| \geq s\},$$

where

$$C(n, s, S) = \begin{cases} \frac{nC_1}{2C_2}, & s = 0; \\ \frac{nC_1}{C_2\sqrt{1-s^2}}, & 0 < s \leq \min\{\sqrt{C_1}, \frac{C_1}{C_2}\}; \\ \frac{ns}{\sqrt{1-s^2}}, & \min\{\sqrt{C_1}, \frac{C_1}{C_2}\} < s < 1. \end{cases}$$

(ii) 
$$\frac{(n+1) \text{Vol}(\mathbb{S}^{n+1})}{n \text{Vol}(\mathbb{S}^n)} \sup_{a \in \mathbb{S}^{n+1}} \text{Vol}\{\varphi_a = 0\} \geq \text{Vol}(M^n).$$

Obviously, if  $M^n$  is a closed immersed minimal CSC hypersurface (nontotally geodesic) in  $\mathbb{S}^{n+1}$ , then  $C_1 = \theta_1 = 1/2n$  in Theorem 1.1 and one has

**Corollary 1.2.** *Let  $M^n$  be a closed immersed, nontotally geodesic, minimal CSC hypersurface in  $\mathbb{S}^{n+1}$ . Then for all  $0 \leq s < 1$  and  $a \in \mathbb{S}^{n+1}$ , the following inequality holds:*

$$\text{Vol}\{|\varphi_a| = s\} \geq C(n, s) \text{Vol}\{|\varphi_a| \geq s\},$$

where

$$C(n, s) = \begin{cases} \frac{1}{4C_2}, & s = 0; \\ \frac{1}{2C_2\sqrt{1-s^2}}, & 0 < s \leq \min\left\{\sqrt{\frac{1}{2n}}, \frac{1}{2nC_2}\right\}; \\ \frac{ns}{\sqrt{1-s^2}}, & \min\left\{\sqrt{\frac{1}{2n}}, \frac{1}{2nC_2}\right\} < s < 1. \end{cases}$$

More precisely, [Corollary 1.2](#) implies that the condition of constant scalar curvature has strong rigidity for minimal hypersurfaces, since the constant  $C(n, s)$  depends only on  $n$  and  $s$ . Hence, the volume of  $M^n$  is strongly restricted by the volume of nodal set of the eigenfunctions  $\varphi_a$  ( $a \in \mathbb{S}^{n+1}$ ) for minimal CSC hypersurfaces (nontotally geodesic), i.e.,

$$C_0(n) \text{Vol}\{\varphi_a = 0\} \geq \text{Vol}(M^n),$$

where  $C_0(n) = C(n, 0) = 4 \inf_{0 \leq r \leq 1} (2 - nr \ln(1 - r^2)) / (2 - n \ln(1 - r^2))$ . Besides, this rigid property provides some evidence for the Chern conjecture.

**Remark 1.3.** Under the conditions of [Corollary 1.2](#), if  $M^n$  is an integral-Einstein (see [Definition 3.1](#)) minimal CSC hypersurface in  $\mathbb{S}^{n+1}$  (or CSC hypersurface with  $S > n$  and constant third mean curvature), then the constant  $C(n, s)$  can be improved (see [Corollary 3.2](#)).

In 1984, Cheng, Li and Yau [\[6\]](#) proved that if  $M^n$  is a closed immersed minimal hypersurface in  $\mathbb{S}^{n+1}$  and  $M^n$  is nontotally geodesic, then

$$\text{Vol}(M^n) > \left(1 + \frac{3}{\tilde{B}_n}\right) \text{Vol}(\mathbb{S}^n),$$

where  $\tilde{B}_n = 2n + 3 + 2 \exp(2n\tilde{C}_n)$  and  $\tilde{C}_n = \frac{1}{2}n^{n/2}e\Gamma(n/2, 1)$ . Thus, we have:

**Corollary 1.4.** Let  $M^n$  be a closed immersed, nontotally geodesic, minimal CSC hypersurface in  $\mathbb{S}^{n+1}$ . Then there is a positive constant  $\epsilon(n) > 0$ , depending only on  $n$ , such that

$$\text{Vol}\{\varphi_a = 0\} \geq \epsilon(n) \text{Vol}(\mathbb{S}^n) \quad \text{for all } a \in \mathbb{S}^{n+1},$$

where  $\epsilon(n) > \frac{1}{4}(1 + 3/\tilde{B}_n) \sup_{0 \leq r \leq 1} ((2 - n \ln(1 - r^2)) / (2 - nr \ln(1 - r^2)))$ .

Let  $h(M)$  denote the Cheeger isoperimetric constant (see [Definition 4.1](#)), we have:

**Theorem 1.5.** Let  $M^n$  be a closed immersed, nontotally geodesic, minimal hypersurface in  $\mathbb{S}^{n+1}$ . Then for all  $a \in \mathbb{S}^{n+1}$  we have

$$\text{Vol}\{\varphi_a = 0\} \geq \frac{2\sqrt{n+1}C_1}{C_0(n)} h(M) \text{Vol}(M^n).$$

In particular, we have the following assertions:

- (i) If  $M^n$  is embedded, then  $h(M) > \frac{1}{10}(-\delta(n-1) + \sqrt{\delta^2(n-1)^2 + 5n})$ , where  $\delta = \sqrt{(S_{\max} - n)/n}$ .
- (ii) If the image of  $M^n$  is invariant under the antipodal map (i.e.,  $M^n$  is radially symmetrical), then  $\text{Vol}\{\varphi_a = 0\} \geq \frac{1}{2}h(M) \text{Vol}(M^n)$ .

### 2. Preliminary lemmas

In this section, we will prove [Lemma 2.3](#) by [Proposition 2.1](#) and [Lemma 2.2](#). A direct calculation shows:

**Proposition 2.1** [[10](#); [13](#)]. For all  $a \in \mathbb{S}^{n+1}$ , we have

$$\begin{aligned} \nabla \varphi_a &= a^T, & \nabla \psi_a &= -A(a^T), \\ \Delta \varphi_a &= -n\varphi_a + nH\psi_a, & \Delta \psi_a &= -n\langle \nabla H, a \rangle + nH\varphi_a - S\psi_a. \end{aligned}$$

where  $a^T \in \Gamma(TM)$  denotes the tangent component of  $a$  along  $M^n$ ;  $A$  is the shape operator with respect to  $\nu$ , i.e.,  $A(X) = -\bar{\nabla}_X \nu$ ;  $S = \|A\|^2 = \text{tr}(AA^t)$  and  $H = \frac{1}{n} \text{tr} A$  is the mean curvature.

**Lemma 2.2** [[10](#)]. Let  $M^n$  be a closed immersed minimal hypersurface in  $\mathbb{S}^{n+1}$  with the squared length of the second fundamental form  $S$ :

- (i) If  $S \not\equiv 0$ , then

$$\frac{\int_M S}{2nS_{\max}} \leq \inf_{a \in \mathbb{S}^{n+1}} \int_M \varphi_a^2.$$

The equality holds if and only if  $S \equiv n$  and  $M^n$  is the minimal Clifford torus  $S^1(\sqrt{1/n}) \times S^{n-1}(\sqrt{(n-1)/n})$ .

- (ii) If  $S$  has no restrictions, then

$$\frac{n}{4n^2 - 3n + 1} \left( \int_M S \right)^2 \leq \int_M S^2 \inf_{a \in \mathbb{S}^{n+1}} \int_M \varphi_a^2.$$

The equality holds if and only if  $M^n$  is an equator.

**Lemma 2.3.** Let  $M^n$  be a closed immersed, nontotally geodesic, minimal hypersurface in  $\mathbb{S}^{n+1}$ . Then for all  $0 \leq s \leq r \leq 1$  and  $a \in \mathbb{S}^{n+1}$ , the following inequality holds:

$$\int_{\{|\varphi_a| \geq s\}} \varphi_a^2 \leq \frac{2 + nr \ln((1-s^2)/(1-r^2))}{2 + n \ln((1-s^2)/(1-r^2))} \int_{\{|\varphi_a| \geq s\}} |\varphi_a|.$$

*Proof.* By [Proposition 2.1](#), we have

$$\nabla \varphi_a = a^T, \quad \Delta \varphi_a = -n\varphi_a,$$

for all  $a \in \mathbb{S}^{n+1}$ . Hence, by the divergence theorem and

$$(2-1) \quad |a^T|^2 + \varphi_a^2 + \psi_a^2 = 1,$$

for all  $0 < t \leq 1$  one has

$$(2-2) \quad \int_{\{|\varphi_a| \geq t\}} |\varphi_a| = \int_{\{|\varphi_a|=t\}} \frac{|a^\top|}{n} = \int_{\{|\varphi_a|=t\}} \frac{\sqrt{1-\varphi_a^2-\psi_a^2}}{n} \leq \int_{\{|\varphi_a|=t\}} \frac{\sqrt{1-t^2}}{n},$$

where  $\{|\varphi_a| \geq t\} = \{x \in M^n : |\varphi_a| \geq t\}$  and  $\{|\varphi_a| = t\} = \{x \in M^n : |\varphi_a| = t\}$ . Due to the coarea formula, (2-1) and (2-2), for all  $0 \leq s < r \leq 1$  we obtain

$$(2-3) \quad \begin{aligned} \int_{\{s \leq |\varphi_a| \leq r\}} |\varphi_a| &= \int_s^r \int_{\{|\varphi_a|=t\}} \frac{|\varphi_a|}{|a^\top|} = \int_s^r \int_{\{|\varphi_a|=t\}} \frac{|\varphi_a|}{\sqrt{1-\varphi_a^2-\psi_a^2}} \\ &\geq \int_s^r \int_{\{|\varphi_a|=t\}} \frac{t}{\sqrt{1-t^2}} \geq \int_s^r \int_{\{|\varphi_a| \geq t\}} \frac{t}{\sqrt{1-t^2}} \frac{n}{\sqrt{1-t^2}} |\varphi_a| \\ &= \int_s^r \int_{\{|\varphi_a| \geq t\}} \frac{nt}{1-t^2} |\varphi_a| \geq \int_{\{|\varphi_a| \geq r\}} |\varphi_a| \int_s^r \frac{nt}{1-t^2} \\ &= \frac{n}{2} \ln\left(\frac{1-s^2}{1-r^2}\right) \int_{\{|\varphi_a| \geq r\}} |\varphi_a|. \end{aligned}$$

For all  $0 \leq s < r \leq 1$ , by  $0 \leq \varphi_a^2 \leq |\varphi_a| \leq 1$  we have

$$(2-4) \quad \begin{aligned} \int_{\{|\varphi_a| \geq s\}} \varphi_a^2 &= \int_{\{|\varphi_a| \geq r\}} \varphi_a^2 + \int_{\{s \leq |\varphi_a| < r\}} \varphi_a^2 \\ &\leq \int_{\{|\varphi_a| \geq r\}} \varphi_a^2 + \int_{\{s \leq |\varphi_a| < r\}} r |\varphi_a| \\ &= \int_{\{|\varphi_a| \geq r\}} \varphi_a^2 + r \int_{\{|\varphi_a| \geq s\}} |\varphi_a| - r \int_{\{|\varphi_a| \geq r\}} |\varphi_a| \\ &\leq (1-r) \int_{\{|\varphi_a| \geq r\}} \varphi_a^2 + r \int_{\{|\varphi_a| \geq s\}} |\varphi_a| \\ &\leq (1-r) \int_{\{|\varphi_a| \geq r\}} |\varphi_a| + r \int_{\{|\varphi_a| \geq s\}} |\varphi_a|. \end{aligned}$$

Thus, for all  $0 \leq s, r, u \leq 1$  and  $s < r$ , by (2-3) and (2-4) we have

$$\begin{aligned} \int_{\{|\varphi_a| \geq s\}} \varphi_a^2 &\leq r \int_{\{|\varphi_a| \geq s\}} |\varphi_a| + (1-r) \int_{\{|\varphi_a| \geq r\}} |\varphi_a| \\ &= r \int_{\{|\varphi_a| \geq s\}} |\varphi_a| + (1-r) \left[ u \int_{\{|\varphi_a| \geq r\}} |\varphi_a| + (1-u) \int_{\{|\varphi_a| \geq s\}} |\varphi_a| \right] \\ &\leq r \int_{\{|\varphi_a| \geq s\}} |\varphi_a| + (1-r) \left[ \frac{2u \int_{\{s \leq |\varphi_a| \leq r\}} |\varphi_a|}{n \ln((1-s^2)/(1-r^2))} + (1-u) \int_{\{|\varphi_a| \geq r\}} |\varphi_a| \right]. \end{aligned}$$

Choosing

$$\frac{2u_0}{n \ln((1-s^2)/(1-r^2))} = 1 - u_0,$$

we have

$$(2-5) \quad u_0 = \frac{n \ln((1-s^2)/(1-r^2))}{2 + n \ln((1-s^2)/(1-r^2))}.$$

Hence, by [Section 2](#) and (2-5) we have

$$\begin{aligned} \int_{\{|\varphi_a| \geq s\}} \varphi_a^2 &\leq r \int_{\{|\varphi_a| \geq s\}} |\varphi_a| + (1-r)(1-u_0) \left( \int_{\{s \leq |\varphi_a| \leq r\}} |\varphi_a| + \int_{\{|\varphi_a| \geq r\}} |\varphi_a| \right) \\ &= [r + (1-r)(1-u_0)] \int_{\{|\varphi_a| \geq s\}} |\varphi_a| \\ &= \frac{2 + nr \ln((1-s^2)/(1-r^2))}{2 + n \ln((1-s^2)/(1-r^2))} \int_{\{|\varphi_a| \geq s\}} |\varphi_a|. \quad \square \end{aligned}$$

In particular, setting  $s = 0$  in [Lemma 2.3](#), we obtain

**Corollary 2.4.** *Let  $M^n$  be a closed immersed, nontotally geodesic, minimal hypersurface in  $\mathbb{S}^{n+1}$ . Then for all  $a \in \mathbb{S}^{n+1}$ , the following inequality holds:*

$$\int_M \varphi_a^2 \leq \frac{C_0(n)}{4} \int_M |\varphi_a|,$$

where  $C_0(n) = 4 \inf_{0 \leq r \leq 1} (2 - nr \ln(1-r^2)) / (2 - n \ln(1-r^2))$ .

### 3. Proof of [Theorem 1.1](#)

In this section, we will prove [Theorem 1.1](#) by [Lemmas 2.2](#) and [2.3](#).

*Proof of [Theorem 1.1](#).* Case (i). Since  $M^n$  is a closed minimal hypersurface (nontotally geodesic) in  $\mathbb{S}^{n+1}$ , by [Lemma 2.2](#) we have

$$(3-1) \quad \inf_{a \in \mathbb{S}^{n+1}} \int_M \varphi_a^2 \geq C_1 \text{Vol}(M^n),$$

where  $C_1 = \max\{\theta_1, \theta_2\}$  and

$$\theta_1 = \frac{\int_M S}{2n S_{\max} \text{Vol}(M^n)}, \quad \theta_2 = \frac{n}{4n^2 - 3n + 1} \frac{(\int_M S)^2}{\text{Vol}(M^n) \int_M S^2}.$$

On one hand, if  $C_1 \geq s^2$ , then (3-1) shows

$$\begin{aligned}
 (3-2) \quad \int_{\{|\varphi_a| \geq s\}} \varphi_a^2 &= \int_M \varphi_a^2 - \int_{\{|\varphi_a| < s\}} \varphi_a^2 \\
 &\geq \int_M C_1 - \int_{\{|\varphi_a| < s\}} s^2 \\
 &= \int_{\{|\varphi_a| \geq s\}} C_1 + \int_{\{|\varphi_a| < s\}} (C_1 - s^2) \\
 &\geq \int_{\{|\varphi_a| \geq s\}} C_1.
 \end{aligned}$$

By Lemma 2.3, (2-2) and (3-2), we obtain

$$\int_{\{|\varphi_a| \geq s\}} C_1 \leq \int_{\{|\varphi_a| \geq s\}} \varphi_a^2 \leq C_2 \int_{\{|\varphi_a| \geq s\}} |\varphi_a| \leq C_2 \int_{\{|\varphi_a| = s\}} \frac{\sqrt{1-s^2}}{n},$$

where  $C_2 = \inf_{s \leq r \leq 1} (2 + nr \ln((1-s^2)/(1-r^2)))/(2 + n \ln((1-s^2)/(1-r^2)))$ . Thus

$$(3-3) \quad \text{Vol} \{|\varphi_a| = s\} \geq \frac{nC_1}{C_2\sqrt{1-s^2}} \text{Vol} \{|\varphi_a| \geq s\} \quad (\sqrt{C_1} \geq s > 0).$$

In particular, if  $s = 0$ , then

$$\lim_{s \rightarrow 0^+} \text{Vol} \{|\varphi_a| = s\} = \lim_{s \rightarrow 0^+} \text{Vol} \{\varphi_a = s\} + \lim_{s \rightarrow 0^+} \text{Vol} \{\varphi_a = -s\} = 2 \text{Vol} \{\varphi_a = 0\},$$

and

$$\lim_{s \rightarrow 0^+} \text{Vol} \{|\varphi_a| \geq s\} = \text{Vol} \{|\varphi_a| \geq 0\} = \text{Vol}(M^n).$$

By (3-3), one has

$$(3-4) \quad \text{Vol} \{\varphi_a = 0\} \geq \frac{nC_1}{2C_2} \text{Vol} \{|\varphi_a| \geq 0\} = \frac{nC_1}{2C_2} \text{Vol}(M^n).$$

On the other hand, by (2-2), we have

$$\int_{\{|\varphi_a| \geq s\}} s \leq \int_{\{|\varphi_a| \geq s\}} |\varphi_a| \leq \int_{\{|\varphi_a| = s\}} \frac{\sqrt{1-s^2}}{n} \quad (1 > s > 0).$$

Hence

$$(3-5) \quad \text{Vol} \{|\varphi_a| = s\} \geq \frac{ns}{\sqrt{1-s^2}} \text{Vol} \{|\varphi_a| \geq s\} \quad (1 > s > 0).$$

Choose

$$\frac{ns}{\sqrt{1-s^2}} = \frac{nC_1}{C_2\sqrt{1-s^2}},$$

which implies that  $s = C_1/C_2$ . Then we have the following discussions:

(1) If  $s = 0$ , (3-4) implies

$$\text{Vol}\{\varphi_a = 0\} \geq \frac{nC_1}{2C_2} \text{Vol}\{|\varphi_a| \geq 0\} = \frac{nC_1}{2C_2} \text{Vol}(M^n).$$

(2) If  $0 < s \leq \min\{\sqrt{C_1}, C_1/C_2\}$ , (3-3) implies

$$\text{Vol}\{|\varphi_a| = s\} \geq \frac{nC_1}{C_2\sqrt{1-s^2}} \text{Vol}\{|\varphi_a| \geq s\}.$$

(3) If  $\min\{\sqrt{C_1}, C_1/C_2\} < s < 1$ , (3-5) implies

$$\text{Vol}\{|\varphi_a| = s\} \geq \frac{ns}{\sqrt{1-s^2}} \text{Vol}\{|\varphi_a| \geq s\}.$$

Case (ii). By Proposition 2.1, we have

$$\nabla\varphi_a = a^T, \quad \Delta\varphi_a = -n\varphi_a,$$

for all  $a \in \mathbb{S}^{n+1}$ . Hence, by the divergence theorem and  $S \neq \emptyset$ , one has

$$\int_M |\varphi_a| = \int_{\{\varphi_a > 0\}} \varphi_a - \int_{\{\varphi_a \leq 0\}} \varphi_a = \int_{\{|\varphi_a|=0\}} \frac{2|a^T|}{n}.$$

Since

$$\int_{a \in \mathbb{S}^{n+1}} |\varphi_a| = 2 \text{Vol}(\mathbb{B}^{n+1}) = \frac{2}{n+1} \text{Vol}(\mathbb{S}^n),$$

we have

$$\frac{2}{n+1} \text{Vol}(\mathbb{S}^n) \text{Vol}(M^n) = \int_{a \in \mathbb{S}^{n+1}} \int_{x \in M} |\varphi_a| = \int_{a \in \mathbb{S}^{n+1}} \int_{\{|\varphi_a|=0\}} \frac{2|a^T|}{n}.$$

By (2-1), one has

$$\text{Vol}(M^n) \leq \frac{(n+1) \text{Vol}(\mathbb{S}^{n+1})}{n \text{Vol}(\mathbb{S}^n)} \sup_{a \in \mathbb{S}^{n+1}} \text{Vol}\{\varphi_a = 0\}. \quad \square$$

Combining the intrinsic and extrinsic geometry, Ge and Li generalized Einstein manifolds to integral-Einstein (IE) submanifolds in [10].

**Definition 3.1** [10]. Let  $M^n$  ( $n \geq 3$ ) be a compact submanifold in the Euclidean space  $\mathbb{R}^N$ . Then  $M^n$  is an IE submanifold if and only if for any unit vector  $a \in \mathbb{S}^{N-1}$

$$\int_M \left( \text{Ric} - \frac{R}{n} \mathbf{g} \right) (a^T, a^T) = 0,$$

where  $a^T \in \Gamma(TM)$  denotes the tangent component of the constant vector  $a$  along  $M^n$ ; Ric is the Ricci curvature tensor and  $R$  is the scalar curvature.



**Corollary 3.2.** *Let  $M^n$  be a closed immersed, nontotally geodesic, minimal hypersurface in  $\mathbb{S}^{n+1}$ . If it is IE and CSC (or CSC with  $S > n$  and constant third mean curvature), then for all  $0 \leq s < 1$  and  $a \in \mathbb{S}^{n+1}$ , the following inequality holds:*

$$\text{Vol}\{|\varphi_a| = s\} \geq C(n, s) \text{Vol}\{|\varphi_a| \geq s\},$$

where

$$C(n, s) = \begin{cases} \frac{n}{2(n+2)C_2}, & s = 0; \\ \frac{n}{(n+2)C_2\sqrt{1-s^2}}, & 0 < s \leq \min\left\{\sqrt{\frac{1}{n+2}}, \frac{1}{(n+2)C_2}\right\}; \\ \frac{ns}{\sqrt{1-s^2}}, & \min\left\{\sqrt{\frac{1}{n+2}}, \frac{1}{(n+2)C_2}\right\} < s < 1. \end{cases}$$

*Proof.* If  $M^n$  is minimal, IE and CSC, then [10] showed that

$$\int_M \varphi_a^2 = \frac{1}{n+2} \text{Vol}(M^n), \quad a \in \mathbb{S}^{n+1}.$$

Thus,  $C_1 = 1/(n+2)$  in Theorem 1.1. For a closed minimal CSC hypersurface in  $\mathbb{S}^{n+1}$  with  $S > n$  and constant third mean curvature, Ge and Li proved that it is an IE hypersurface in [10]. Thus, Corollary 3.2 is also true in this case.  $\square$

#### 4. Proof of Theorem 1.5

In this section, we will discuss the Cheeger isoperimetric constant of minimal hypersurfaces in  $\mathbb{S}^{n+1}$ .

**Definition 4.1** [5]. The Cheeger isoperimetric constant of a closed Riemannian manifold  $M^n$  is defined as

$$h(M) = \inf_H \frac{\text{Vol}(H)}{\min\{\text{Vol}(M_1), \text{Vol}(M_2)\}},$$

where the infimum is taken over all the submanifolds  $H$  of codimension 1 of  $M^n$ ;  $M_1$  and  $M_2$  are submanifolds of  $M^n$  with their boundaries in  $H$  and satisfy  $M = M_1 \sqcup M_2 \sqcup H$  (a disjoint union).

**Remark 4.2.** Let  $M^n$  be a closed, immersed, minimal hypersurface in  $\mathbb{S}^{n+1}$ , which is nontotally geodesic. Since there is a vector  $a \in \mathbb{S}^{n+1}$  such that  $\text{Vol}\{\varphi_a > 0\} = \text{Vol}\{\varphi_a < 0\}$ , we have

$$h(M) \leq \sup_{a \in \mathbb{S}^{n+1}} \frac{2 \text{Vol}\{\varphi_a = 0\}}{\text{Vol}(M^n)}.$$

Moreover, if the image of  $M^n$  is invariant under the antipodal map, then  $\text{Vol}\{\varphi_a > 0\} = \text{Vol}\{\varphi_a < 0\}$  for all  $a \in \mathbb{S}^{n+1}$  and

$$h(M) \leq \inf_{a \in \mathbb{S}^{n+1}} \frac{2 \text{Vol}\{\varphi_a = 0\}}{\text{Vol}(M^n)}.$$

In 1970, Cheeger [5] gave the famous inequality between the first positive eigenvalue  $\lambda_1(M)$  of the Laplacian and the Cheeger isoperimetric constant  $h(M)$  (see Definition 4.1):

$$h^2(M) \leq 4\lambda_1(M).$$

Obviously,  $\lambda_1(M) \leq n$  for minimal hypersurfaces in  $\mathbb{S}^{n+1}$  because of Proposition 2.1 and we have

$$h(M) \leq 2\sqrt{\lambda_1(M)} \leq 2\sqrt{n}.$$

The Yau conjecture [16] asserts that if  $M^n$  is a closed embedded minimal hypersurface of  $\mathbb{S}^{n+1}$ , then  $\lambda_1(M) = n$ . In particular, Choi and Wang [9] showed that  $\lambda_1(M) \geq n/2$  and a careful argument (see [1, Theorem 5.1]) implied that the strict inequality holds, i.e.,  $\lambda_1(M) > n/2$ . In addition, Tang and Yan [21; 19] proved the Yau conjecture in the isoparametric case. Choe and Soret [8] were able to verify the Yau conjecture for the Lawson surfaces and the Karcher-Pinkall-Sterling examples. For more details and references, please see the elegant survey by Brendle [1]. Besides, Buser [3] proved that:

**Lemma 4.3** [3]. *If the Ricci curvature of a closed Riemannian manifold  $M^n$  is bounded below by  $-(n-1)\delta^2$  ( $\delta \geq 0$ ), then*

$$(4-1) \quad \lambda_1(M) \leq 2\delta(n-1)h(M) + 10h^2(M).$$

Next, we will prove Theorem 1.5 by Lemmas 2.2, 4.3 and Corollary 2.4.

*Proof of Theorem 1.5.* Without loss of generality, assuming that  $\text{Vol}\{\varphi_a > 0\} \geq \text{Vol}\{\varphi_a < 0\}$ , one has

$$(4-2) \quad h(M) \leq \frac{\text{Vol}\{\varphi_a = 0\}}{\text{Vol}\{\varphi_a < 0\}}.$$

For  $\text{Vol}\{\varphi_a > 0\} \leq \text{Vol}\{\varphi_a < 0\}$ , the proof is similar and the following estimates of inequalities can be found in Ge and Li [11]. By Proposition 2.1, for any  $a \in \mathbb{S}^{n+1}$ ,  $\int_M \varphi_a = 0$ . Thus

$$(4-3) \quad \int_{\{\varphi_a > 0\}} \varphi_a = \int_{\{\varphi_a < 0\}} -\varphi_a = \frac{1}{2} \int_M |\varphi_a|.$$

The divergence theorem shows that

$$\int_{\{\varphi_a < 0\}} \Delta \varphi_a^2 = 0,$$

and by  $\Delta\varphi_a^2 = -2n\varphi_a^2 + 2|a^T|^2$ , one has

$$(4-4) \quad n \int_{\{\varphi_a < 0\}} \varphi_a^2 = \int_{\{\varphi_a < 0\}} |a^T|^2.$$

Then, due to (2-1) and (4-4), we have

$$(4-5) \quad (n+1) \int_{\{\varphi_a < 0\}} \varphi_a^2 \leq \int_{\{\varphi_a < 0\}} 1.$$

By the Cauchy-Schwarz inequality and (4-5), one has

$$(4-6) \quad \sqrt{\frac{1}{n+1}} \int_{\{\varphi_a < 0\}} 1 \geq \sqrt{\int_{\{\varphi_a < 0\}} 1 \int_{\{\varphi_a < 0\}} \varphi_a^2} \geq \int_{\{\varphi_a < 0\}} -\varphi_a.$$

By Corollary 2.4, (4-2), (4-3) and (4-6), we have

$$\frac{\text{Vol}\{\varphi_a = 0\}}{h(M)} \geq \text{Vol}\{\varphi_a < 0\} \geq \frac{\sqrt{n+1}}{2} \int_M |\varphi_a| \geq \frac{2\sqrt{n+1}}{C_0(n)} \int_M \varphi_a^2.$$

Hence, by Lemma 2.2 we have

$$\text{Vol}\{\varphi_a = 0\} \geq \frac{2\sqrt{n+1}}{C_0(n)} h(M) \int_M \varphi_a^2 \geq \frac{2\sqrt{n+1}C_1}{C_0(n)} h(M) \text{Vol}(M^n).$$

Case (i). Since  $M^n$  is a minimal hypersurface in  $\mathbb{S}^{n+1}$ , the Ricci curvature is given by

$$\text{Ric}(X, Y) = (n-1)g(X, Y) - g(AX, AY), \quad X, Y \in \mathfrak{X}(M).$$

Let  $\lambda_1(A), \lambda_2(A), \dots, \lambda_n(A)$  denote the eigenvalues of the shape operator  $A$ . We obtain

$$\sum_{i=1}^n \lambda_i = 0, \quad \sum_{i=1}^n \lambda_i^2 = \|A\|^2 = S,$$

and

$$\begin{aligned} 0 &= \sum_{i,j=1}^n \lambda_i \lambda_j \\ &= \lambda_1^2 + 2 \sum_{j=2}^n \lambda_1 \lambda_j + \sum_{i,j=2}^n \lambda_i \lambda_j \\ &\leq -\lambda_1^2 + \sum_{i,j=2}^n \frac{\lambda_i^2 + \lambda_j^2}{2} \\ &= (n-1)S - n\lambda_1^2. \end{aligned}$$

Thus

$$\operatorname{Ric}(X, X) \geq (n-1 - \lambda_1^2)g(X, X) \geq -(n-1)\frac{S-n}{n}g(X, X).$$

By [Lemma 4.3](#) and  $\lambda_1(M) > n/2$  (see [Choi–Wang \[9\]](#) and [Brendle \[1\]](#)), one has

$$\frac{n}{2} < \lambda_1(M) \leq 2\delta(n-1)h(M) + 10h^2(M).$$

Note that  $S_{\max} \geq n$  for all nontotally geodesic minimal hypersurfaces in  $\mathbb{S}^{n+1}$  by [Simons' inequality \[17\]](#)

$$\int_M S(S-n) \geq 0.$$

Setting  $\delta = \sqrt{(S_{\max} - n)/n}$ , we have

$$h(M) > \frac{-\delta(n-1) + \sqrt{\delta^2(n-1)^2 + 5n}}{10}.$$

Case (ii). If the image of  $M^n$  is invariant under the antipodal map, the proof is complete by [Remark 4.2](#).  $\square$

**Remark 4.4.** If  $M^n$  is a minimal isoparametric hypersurface with  $g \geq 2$  distinct principal curvatures in  $\mathbb{S}^{n+1}$ , then  $\lambda_1(M) = n$  (see [Tang–Yan \[19\]](#)),  $S \equiv (g-1)n$  and  $\delta = \sqrt{g-2}$  ( $2 \leq g \leq 6$ ). Thus, [\(4-1\)](#) implies that

$$h(M) \geq \frac{-\sqrt{g-2}(n-1) + \sqrt{(g-2)(n-1)^2 + 10n}}{10}.$$

In fact, [Muto \[12\]](#) carefully estimated the Cheeger isoperimetric constant of minimal isoparametric hypersurfaces and got better results.

**Remark 4.5.** Let  $M^n$  be a closed embedded minimal hypersurface in  $\mathbb{S}^{n+1}$ . If  $S < c(n)$  and  $c(n)$  depends only on  $n$ , then there is a positive constant  $\eta(n) > 0$ , depending only on  $n$ , such that  $h(M) > \eta(n)$ .

## Acknowledgments

The authors sincerely thank the referee for their many valuable and constructive suggestions, which made this paper more readable. They also thank Professors Zizhou Tang and Jianquan Ge for their very detailed and valuable comments.

## References

- [1] S. Brendle, “Minimal surfaces in  $S^3$ : a survey of recent results”, *Bull. Math. Sci.* **3**:1 (2013), 133–171. [MR](#) [Zbl](#)
- [2] S. Brendle, “The isoperimetric inequality for a minimal submanifold in Euclidean space”, *J. Amer. Math. Soc.* **34**:2 (2021), 595–603. [MR](#) [Zbl](#)

- [3] P. Buser, “A note on the isoperimetric constant”, *Ann. Sci. École Norm. Sup. (4)* **15**:2 (1982), 213–230. [MR](#) [Zbl](#)
- [4] S. Chang, “On minimal hypersurfaces with constant scalar curvatures in  $S^4$ ”, *J. Differential Geom.* **37**:3 (1993), 523–534. [MR](#) [Zbl](#)
- [5] J. Cheeger, “A lower bound for the smallest eigenvalue of the Laplacian”, pp. 195–199 in *Problems in analysis* (Sympos. in honor of Salomon Bochner, Princeton Univ., N.J., 1969), edited by R. C. Gunning, Princeton Univ. Press, 1970. [MR](#) [Zbl](#)
- [6] S. Y. Cheng, P. Li, and S.-T. Yau, “Heat equations on minimal submanifolds and their applications”, *Amer. J. Math.* **106**:5 (1984), 1033–1065. [MR](#) [Zbl](#)
- [7] J. Choe and R. Gulliver, “Isoperimetric inequalities on minimal submanifolds of space forms”, *Manuscripta Math.* **77**:2-3 (1992), 169–189. [MR](#) [Zbl](#)
- [8] J. Choe and M. Soret, “First eigenvalue of symmetric minimal surfaces in  $S^3$ ”, *Indiana Univ. Math. J.* **58**:1 (2009), 269–281. [MR](#) [Zbl](#)
- [9] H. I. Choi and A. N. Wang, “A first eigenvalue estimate for minimal hypersurfaces”, *J. Differential Geom.* **18**:3 (1983), 559–562. [MR](#) [Zbl](#)
- [10] J. Ge and F. Li, “Integral-Einstein hypersurfaces in spheres”, preprint, 2021. [arXiv 2101.03753](#)
- [11] J. Ge and F. Li, “Volume gap for minimal submanifolds in spheres”, preprint, 2022. [Zbl](#) [arXiv 2210.04654](#)
- [12] H. Muto, “The first eigenvalue of the Laplacian of an isoparametric minimal hypersurface in a unit sphere”, *Math. Z.* **197**:4 (1988), 531–549. [MR](#) [Zbl](#)
- [13] K. Nomizu and B. Smyth, “On the Gauss mapping for hypersurfaces of constant mean curvature in the sphere”, *Comment. Math. Helv.* **44** (1969), 484–490. [MR](#)
- [14] R. Osserman, “The isoperimetric inequality”, *Bull. Amer. Math. Soc.* **84**:6 (1978), 1182–1238. [MR](#) [Zbl](#)
- [15] M. Scherfner, S. Weiss, and S.-T. Yau, “A review of the Chern conjecture for isoparametric hypersurfaces in spheres”, pp. 175–187 in *Advances in geometric analysis*, edited by S. Janeczko et al., Adv. Lect. Math. (ALM) **21**, International Press, Somerville, MA, 2012. [MR](#) [Zbl](#)
- [16] R. Schoen and S.-T. Yau, *Lectures on differential geometry*, Conference Proceedings and Lecture Notes in Geometry and Topology **1**, International Press, Cambridge, MA, 1994. [MR](#) [Zbl](#)
- [17] J. Simons, “Minimal varieties in riemannian manifolds”, *Ann. of Math. (2)* **88** (1968), 62–105. [MR](#) [Zbl](#)
- [18] T. Takahashi, “Minimal immersions of Riemannian manifolds”, *J. Math. Soc. Japan* **18** (1966), 380–385. [MR](#) [Zbl](#)
- [19] Z. Tang and W. Yan, “Isoparametric foliation and Yau conjecture on the first eigenvalue”, *J. Differential Geom.* **94**:3 (2013), 521–540. [MR](#) [Zbl](#)
- [20] Z. Tang and W. Yan, “On the Chern conjecture for isoparametric hypersurfaces”, *Sci. China Math.* **66**:1 (2023), 143–162. [MR](#) [Zbl](#)
- [21] Z. Tang, Y. Xie, and W. Yan, “Isoparametric foliation and Yau conjecture on the first eigenvalue, II”, *J. Funct. Anal.* **266**:10 (2014), 6174–6199. [MR](#) [Zbl](#)
- [22] Z. Tang, D. Wei, and W. Yan, “A sufficient condition for a hypersurface to be isoparametric”, *Tohoku Math. J. (2)* **72**:4 (2020), 493–505. [MR](#) [Zbl](#)
- [23] H. Yang and Q.-M. Cheng, “Chern’s conjecture on minimal hypersurfaces”, *Math. Z.* **227**:3 (1998), 377–390. [MR](#) [Zbl](#)
- [24] S. T. Yau, “Isoperimetric constants and the first eigenvalue of a compact Riemannian manifold”, *Ann. Sci. École Norm. Sup. (4)* **8**:4 (1975), 487–507. [MR](#) [Zbl](#)

Received March 13, 2022. Revised November 24, 2022.

FAGUI LI  
BEIJING INTERNATIONAL CENTER FOR MATHEMATICAL RESEARCH  
PEKING UNIVERSITY  
BEIJING  
CHINA

[faguili@bicmr.pku.edu.cn](mailto:faguili@bicmr.pku.edu.cn)

and

SCHOOL OF MATHEMATICAL SCIENCES  
LABORATORY OF MATHEMATICS AND COMPLEX SYSTEMS  
BEIJING NORMAL UNIVERSITY  
BEIJING  
CHINA

NIANG CHEN  
DEPARTMENT OF MATHEMATICS  
FACULTY OF ARTS AND SCIENCES  
BEIJING NORMAL UNIVERSITY AT ZHUHAI  
ZHUHAI  
CHINA

[chenni@bnu.edu.cn](mailto:chenni@bnu.edu.cn)

# BOUNDARY REGULARITY OF BERGMAN KERNEL IN HÖLDER SPACE

ZIMING SHI

Let  $D$  be a bounded strictly pseudoconvex domain in  $\mathbb{C}^n$ . Assuming  $bD \in C^{k+3+\alpha}$  where  $k$  is a nonnegative integer and  $0 < \alpha \leq 1$ , we show that (1) the Bergman kernel  $B(\cdot, w_0) \in C^{k+\min\{\alpha, 1/2\}}(\bar{D})$ , for any  $w_0 \in D$  and (2) the Bergman projection on  $D$  is a bounded operator from  $C^{k+\beta}(\bar{D})$  to  $C^{k+\min\{\alpha, \beta/2\}}(\bar{D})$  for any  $0 < \beta \leq 1$ . Our results both improve and generalize the work of E. Ligocka.

1. Introduction	157
2. Preliminaries	160
3. Estimates of the kernel	163
4. Proof of Proposition 1.2 and Theorem 1.1	183
5. Proof of Theorem 1.3	197
Acknowledgements	205
References	205

## 1. Introduction

The main goal of the paper is to prove the following result.

**Theorem 1.1.** *Let  $D$  be a bounded strictly pseudoconvex domain in  $\mathbb{C}^n$  with  $C^{k+3+\alpha}$  boundary, where  $k$  is a nonnegative integer and  $0 < \alpha \leq 1$ . Let  $B(z, w)$  be the Bergman kernel for  $D$ . Then for every  $w_0 \in D$ ,  $B(\cdot, w_0) \in C^{k+\min\{\alpha, 1/2\}}(\bar{D})$ .*

Earlier, E. Ligocka [1984] showed that if  $\Omega$  has  $C^{k+4}$  boundary for nonnegative integers  $k$ , then  $B(\cdot, w_0) \in C^{k+1/2}(\bar{D})$ . Hence Theorem 1.1 is an improvement and generalization of Ligocka's result to Hölder spaces.

The study of boundary regularity properties of the Bergman projection and Bergman kernel is of fundamental importance in several complex variables, and the subject has found major applications in the theory of biholomorphic mappings and complex geometry, among many other fields. We mention here some brief history for the results on strictly pseudoconvex domains. When the boundary is  $C^\infty$ , Kerzman [1972] used the theory of  $\bar{\partial}$ -Neumann problem to show that the

*MSC2020:* primary 32A25; secondary 32T15.

*Keywords:* Bergman kernel, Bergman projection, strictly pseudoconvex domain.

Bergman kernel function  $B(z, w)$  is  $C^\infty \times C^\infty(\bar{D} \times \bar{D} \setminus \Delta_{bD})$ , where  $\Delta_{bD} := \{(z, w) \in bD \times bD, z = w\}$ . Soon after, C. Fefferman in his seminal paper [1974] gave a description of the behavior of the Bergman kernel  $(z, w) \in bD \times bD$  near its singular set  $\Delta_{bD}$ , and as an application he proved the now classical Fefferman's mapping theorem, which states that a biholomorphic mapping  $F : D_1 \rightarrow D_2$  between two bounded  $C^\infty$  strictly pseudoconvex domains  $D_1, D_2$  extends to a  $C^\infty$  diffeomorphism  $\tilde{F} : \bar{D}_1 \rightarrow \bar{D}_2$ . Fefferman's proof was based on the deep properties of the Bergman kernel and Bergman metric on strictly pseudoconvex domains. The analysis however was very difficult and nearly impossible to generalize to other cases. Later on Webster [1979] and Bell and Ligocka [1980] independently found conditions on the boundary behavior of the Bergman kernel that can imply the  $C^\infty$  extension of biholomorphic mappings, and consequently they were able to significantly simplify Fefferman's proof.

Phong and Stein [1977] and Ahern and Schneider [1979] independently proved the Hölder estimates for the Bergman projection. In both work the boundary is assumed to be  $C^\infty$  and the proof is based on the work of C. Fefferman [1974] and L. Boutet de Monvel and J. Sjöstrand [1976]. Later on, Ligocka [1984] constructed a nonorthogonal projection operator with explicit kernels that "approximates" the Bergman projection operator, and she used it to prove the Hölder estimates assuming boundary is  $C^{k+4}$ . Ligocka based off her construction on a similar work done by Kerzman and Stein [1978] for the Szegő projection on  $C^\infty$  strictly pseudoconvex domains. The idea is to use the symmetry of the Levi polynomial for the defining function to get a third order cancellation, which then allows one to estimate the singular integrals (see Proposition 3.1). It is also worthwhile to mention that the method of Kerzman, Stein and Ligocka has been used in a number of subsequent works, for example in [Lanzani and Stein 2012; 2013]. For a detailed exposition of the work by Ligocka and Bell and Kerzman, Stein and Ligocka, we refer the reader to the book by M. Range [Range 1986, Chapter VII].

We shall give a variant of Ligocka's method which allows us to prove the estimates in Hölder spaces. Our method also has the advantage that the term on the right-hand side of our integral equation behaves much nicer than the one used by Ligocka, which we now explain. Denote the Bergman projection on  $D$  by  $\mathcal{P}$ . It is a standard fact that for  $w_0 \in D$ , one can write  $B(\cdot, w_0) = \mathcal{P}\varphi$ , where  $\varphi = \varphi_{w_0} \in C_c^\infty(D)$  (see Lemma 2.4). Ligocka showed that  $\mathcal{P}\varphi$  satisfies an integral equation of the form

$$(1-1) \quad (I + \mathcal{K})\mathcal{P}\varphi = \mathcal{L}^*\varphi.$$

Here  $\mathcal{L}$  is a nonorthogonal projection operator mapping  $L^2(\Omega)$  into  $H^2(\Omega)$ , the  $L^2$  Bergman space,  $\mathcal{L}^*$  is the adjoint operator of  $\mathcal{L}$ , and  $\mathcal{K} := \mathcal{L}^* - \mathcal{L}$ . It was proved in [Ligocka 1984] that if the boundary is  $C^{k+4}$ , then  $\mathcal{K}$  is a compact operator



mapping  $C^k(\bar{D})$  into  $C^{k+1/2}(\bar{D})$ , and  $\mathcal{L}, \mathcal{L}^*$  map  $C^{k+1}(\bar{D})$  (in fact only need derivatives of order  $k$  being Lipschitz continuous) into  $C^{k+1/2}(\bar{D})$ . Hence in particular  $\mathcal{L}^*\varphi \in C^{k+1/2}(\bar{D})$ . Applying Fredholm theory to the integral (1-1) then shows that  $\mathcal{P}\varphi \in C^{k+1/2}(\bar{D})$ .

For our proof we shall use the same operators  $\mathcal{L}, \mathcal{L}^*, \mathcal{K}$ , but instead of considering the integral equation of  $\mathcal{P}\varphi$ , we show that the following integral equation holds for the function  $\mathcal{P}\varphi - \varphi$

$$(1-2) \quad (I + \mathcal{K})(\mathcal{P}\varphi - \varphi) = R(\mathcal{P}\varphi - \varphi),$$

where  $R$  is some operator that maps  $\mathcal{P}\varphi - \varphi$  to a  $C^\infty(\bar{D})$  function, assuming boundary is only  $C^3$ . This is in contrast to the right-hand side of (1-1), where the regularity of  $\mathcal{L}^*\varphi$  depends on the regularity of the boundary and the estimate is much more complicated.

Using (1-2), Theorem 1.1 is then an easy consequence of the following compactness result and Fredholm theory.

**Proposition 1.2.** *Let  $D$  be a bounded strictly pseudoconvex domain in  $\mathbb{C}^n$  with  $C^{k+3+\alpha}$  boundary, where  $k$  is a nonnegative integer and  $0 < \alpha \leq 1$ . Then  $\mathcal{K}$  is a bounded operator from  $C^k(\bar{D})$  to  $C^{k+\min\{\alpha, 1/2\}}(\bar{D})$ .*

We remark that Proposition 1.2 is the main estimate of the paper and takes up the majority of the proof.

Using Proposition 1.2 we can also prove the following theorem for the Bergman projection. Similar result has been obtained by Ligocka under the assumption that the boundary is  $C^{k+4}$ .

**Theorem 1.3.** *Let  $D$  be a bounded strictly pseudoconvex domain in  $\mathbb{C}^n$  with  $C^{k+3+\alpha}$  boundary, where  $k$  is a nonnegative integer and  $0 < \alpha \leq 1$ . For  $0 < \beta \leq 1$ , the Bergman projection  $\mathcal{P}$  for the domain  $D$  defines a bounded operator from  $C^{k+\beta}(\bar{D})$  to  $C^{k+\min\{\alpha, \beta/2\}}(\bar{D})$ .*

In the special case  $\alpha = 1$ , we recover Ligocka's result. Note that Theorem 1.1 can also be obtained as a consequence of Theorem 1.3, by the fact that  $B = P\varphi$  and setting  $\beta = 1$  in Theorem 1.3. However we shall give independent proofs of the two theorems based on Proposition 1.2.

The paper is organized as follows: In Section 2, we prove a simple estimate for Hörmander's  $\bar{\partial}$  solution operator on pseudoconvex domains. We also prove a refined version of the regularized defining function introduced in [Gong 2019], which plays an important role in the proof of Proposition 1.2. In Section 3 we follow Ligocka's idea to construct the operators  $\mathcal{L}, \mathcal{L}^*, \mathcal{K}$ , using the regularized defining function from Section 2. We then prove various estimates for the kernels of  $\mathcal{L}, \mathcal{L}^*, \mathcal{K}$ . We note that in our proof (Proposition 3.5 and the remark after) that  $\mathcal{L}$

defines a bounded projection operator from  $L^2(D)$  to  $H^2(D)$ , only  $C^3$  boundary regularity is needed.

In Section 4 we will prove Proposition 1.2 and Theorem 1.1. The proof of Proposition 1.2 is split into two parts. In the first part, we prove the case for  $k = 0$ , i.e., assuming  $bD \in C^{3+\alpha}$ ,  $0 < \alpha \leq 1$ , we show that  $\mathcal{K}$  maps  $L^\infty(D)$  boundedly into  $C^{\min\{\alpha, 1/2\}}(\bar{D})$ . In the second part, we apply the integration by parts techniques from [Ahern and Schneider 1979] to prove the case for  $k \geq 1$ . We next turn to the proof of Theorem 1.1. First we construct the integral (1-2) using Koppleman’s homotopy formula and show that the right-hand side defines a  $C^\infty(\bar{D})$  function. Theorem 1.1 then follows easily from Proposition 1.2 and standard Fredholm theory. In Section 5 we prove Theorem 1.3. To this end we show that  $\mathcal{L}$  is a bounded operator from  $C^{k+\beta}(\bar{D})$  to  $C^{k+\beta/2}(\bar{D})$ ,  $0 < \beta \leq 1$ , assuming boundary is  $C^3$ .

We now fix some notations used in the paper. The  $L^2$  Bergman space on a domain  $D$  is denoted by  $H^2(D)$ . The Bergman projection and Bergman kernel is denoted by  $\mathcal{P}$  and  $B$ , respectively. We denote by  $C^r(\bar{D})$  the Hölder space of exponent  $r$  on  $D$ , and  $C_c^\infty(D)$  the space of  $C^\infty$  functions with compact support in  $D$ . For simplicity we write  $\|f\|_r := \|f\|_{C^r(\bar{D})}$  when the domain  $D$  is clear from context. We write  $x \lesssim y$  to mean that  $x \leq Cy$  for some constant  $C$  independent of  $x$  and  $y$ . By  $D^l$  we mean a differential operator of order  $l$ :  $D_z^l g(z) = \partial_{z_i}^{\alpha_i} \partial_{\bar{z}_j}^{\beta_j} g(z)$ ,  $\sum_i \alpha_i + \sum_j \beta_j = l$ .

## 2. Preliminaries

**Proposition 2.1.** *Let  $D, D'$  be bounded pseudoconvex domains in  $\mathbb{C}^n$  such that  $D' \subset D$ , and let  $l \geq 0$ . Suppose  $\varphi$  is a  $\bar{\partial}$ -closed  $(0, 1)$  form in  $D$ , with coefficients in  $W^1(D)$ . Let  $u = S\varphi$ , where  $S$  is Hörmander’s  $L^2$  solution operator which solves  $\bar{\partial}$  on  $D$ . Then  $u \in W^{l+1}(D')$ , and*

$$\|u\|_{W^{l+1}(D')} \leq C(\delta/2)^{-l-1} \|\varphi\|_{W^1(D)}, \quad \delta := \text{dist}(D', \partial D),$$

where  $C$  is an absolute constant depending only on the domain  $D$ ,

*Proof.* By Hörmander’s  $L^2$  estimate [1965], we have  $\bar{\partial}u = \varphi$  and

$$(2-1) \quad \|u\|_{L^2(D)} \leq C_0 \|\varphi\|_{L^2(D)},$$

where  $C_0$  is a constant which depends only on the diameter of  $D$ . Let  $\chi \in C_c^\infty(D)$  be such that  $\chi \equiv 1$  on  $D'$ . Further,  $\chi$  satisfies the estimate  $|D^\gamma \chi| \leq \delta^{-|\gamma|}$ , where  $\delta := \text{dist}(D', D)$ . We use the following fact: If  $v \in L^2(\mathbb{C}^n)$  has compact support and  $\bar{\partial}v \in L^2(\mathbb{C}^n)$ , then

$$(2-2) \quad \|\partial_{z_i} v\|_{L^2(\mathbb{C}^n)} = \|\partial_{\bar{z}_i} v\|_{L^2(\mathbb{C}^n)}.$$

This can be proved through a simple integration by parts and approximation argument; see [Hörmander 1990, Lemma 4.2.4]. In what follows we let  $D^l$  to denote a differential operator of the form  $\prod_{i,j=1}^n \partial_{z_i}^{\alpha_i} \partial_{\bar{z}_j}^{\beta_j}$ , where  $\sum_{i,j=1}^n |\alpha_i| + |\beta_j| = l$ , and we use  $\bar{\partial}^l$  to denote  $\prod_{j=1}^n \partial_{\bar{z}_j}^{\beta_j}$ , where  $\sum \beta_j = l$ . Applying (2-2) repeatedly then gives

$$(2-3) \quad \|D^{l+1}v\|_{L^2(\mathbb{C}^n)} = \|\bar{\partial}^{l+1}v\|_{L^2(\mathbb{C}^n)}$$

for any  $v \in L^2(\mathbb{C}^n)$  with compact support and such that  $\bar{\partial}^{l+1}v \in L^2(\mathbb{C}^n)$ . Applying (2-3) with  $v = \chi u$ , we get

$$(2-4) \quad \|D^{l+1}(\chi u)\|_{L^2(D)} = \|\bar{\partial}^{l+1}(\chi u)\|_{L^2(D)} \\ \leq \|(\bar{\partial}^{l+1}\chi)u\|_{L^2(D)} + \sum_{1 \leq s \leq l+1} \|(\bar{\partial}^{l+1-s}\chi)(\bar{\partial}^s u)\|_{L^2(D)}.$$

By (2-1) and estimates for the derivatives of  $\chi$ , the first integral is bounded by  $C_0\delta^{-(l+1)}\|\varphi\|_{L^2(D)}$ . For each integral in the sum, we have for  $1 \leq s \leq l+1$

$$\|(\bar{\partial}^{l+1-s}\chi)(\bar{\partial}^s u)\|_{L^2(D)} = \|(\bar{\partial}^{l+1-s}\chi)(\bar{\partial}^{s-1}\bar{\partial}u)\|_{L^2(D)} \\ \leq \delta^{-(l+1-s)}\|\varphi\|_{W^{s-1}(D)} \leq \delta^{-l}\|\varphi\|_{W^1(D)}.$$

Now, there are in total  $\sum_{k=0}^{l+1} \binom{l+1}{k} = 2^{l+1}$  terms on the right-hand side of (2-4). Thus by combining the estimates we obtain

$$\|D^{l+1}(\chi u)\|_{L^2(D)} \leq C_0 2^{l+1} \delta^{-(l+1)} \|\varphi\|_{W^1(D)} = C_0 (\delta/2)^{-(l+1)} \|\varphi\|_{W^1(D)}.$$

Since  $\chi \equiv 1$  on  $D'$ , we have

$$\|D^{l+1}u\|_{L^2(D')} \leq \|D^{l+1}(\chi u)\|_{L^2(D)} \leq C_0 (\delta/2)^{-(l+1)} \|\varphi\|_{W^1(D)}. \quad \square$$

We now show the existence of a defining function that is smooth off the boundary and whose derivatives blow up in a controlled way.

**Proposition 2.2.** *Let  $D$  be a bounded domain in  $\mathbb{R}^N$  with  $C^r$  boundary,  $r \geq 3$ , and let  $\rho$  be a defining function of  $D$  of the class  $C^r$ , i.e., there exists a  $\mathcal{U}$  such that  $D \subset \mathcal{U}$ ,  $\nabla \rho \neq 0$  on  $bD$  and  $D = \{x \in \mathcal{U} : \rho(x) < 0\}$ . We denote  $|\rho|_r := |\rho|_{C^r(\mathcal{U})}$ , where  $|\cdot|_{C^r(\mathcal{U})}$  denotes the Hölder  $r$ -norm on  $\mathcal{U}$ . Then there exists a defining function  $\tilde{\rho}$  of  $D$  such that:*

- (a)  $\tilde{\rho} \in C^r(\mathbb{R}^N) \cap C^\infty(\mathbb{R}^N \setminus bD)$ .
- (b) *There exists some  $\delta_0 > 0$  such that for any  $x \notin bD$  and  $0 < \delta(x) := \text{dist}(x, bD) < \delta_0$ ,*

$$|D^j \tilde{\rho}(x)| \lesssim C_j |\rho|_r (1 + \delta(x)^{r-j}), \quad j = 0, 1, 2, \dots, \delta(x) := \text{dist}(x, bD).$$

(c) *There exists a constant  $C$  depending only on the domain  $D$  and  $|\rho|_3$ , and a  $\delta_1 > 0$  such that for all  $x \in \mathbb{R}^n$  with  $\delta(x) < \delta_1$  the following estimate hold*

$$|\widehat{D}^2 \tilde{\rho}(x) - \widehat{D}^2 \rho(x_*)| \lesssim C|x - x_*|, \quad |x_* - x| := \text{dist}(x, bD).$$

Here we use  $\widehat{D}^2 \rho$  to denote derivatives of  $\rho$  of order 2 and less.

We call  $\tilde{\rho}$  a *regularized defining function* of the domain  $D$ .

*Proof.* We will use the argument from [Gong 2019]. Let  $E_r$  be the Whitney extension operator for the domain  $D$ . By [Gong 2019, Lemma 3.7],  $E_r \rho$  is a defining function of  $D$  (so that  $-E_r \rho$  is a defining function of the domain  $(\bar{D})^c$ ),  $E_r \rho \in C^r(\mathbb{R}^N) \cap C^\infty((\bar{D})^c)$  and

$$|D^j E_r \rho(x)| \lesssim C_j |\rho|_r (1 + \delta(x)^{r-j}), \quad j = 0, 1, 2, \dots, x \in \mathbb{R}^n \setminus \bar{D}.$$

Furthermore, for each  $x \in \mathbb{R}^n \setminus \bar{D}$  with  $0 < \delta(x) < 1$ , there exists some constant  $C$  depending only on  $D$  and  $|\rho|_3$  such that  $|\widehat{D}^2(E_r \rho)(x) - \widehat{D}^2 \rho(x_*)| \leq C|x - x_*|$ , where  $x_* := \text{dist}(x, bD)$ . Let  $E'_r$  be the Whitney extension operator for the domain  $(\bar{D})^c$ . Then by the same reasoning  $\tilde{\rho} := E'_r E_r \rho$  is a defining function of  $D$  satisfying  $\tilde{\rho} \in C^r(\mathbb{R}^N) \cap C^\infty(\mathbb{R}^n \setminus bD)$ , and for all  $x \in D$  with  $0 < \delta(x) < \delta_1$ , the following hold (for  $j = 0, 1, 2, \dots, x \in D$ )

$$\begin{aligned} |D^j \tilde{\rho}(x)| &\lesssim C'_j |E_r \rho|_r (1 + \delta(x)^{r-j}) \lesssim C''_j |\rho|_r (1 + \delta(x)^{r-j}), \\ |\widehat{D}^2 \tilde{\rho}(x) - \widehat{D}^2 \rho(x_*)| &= |\widehat{D}^2 \tilde{\rho}(x) - \widehat{D}^2(E_r \rho)(x_*)| \leq C'|x - x_*|, \end{aligned}$$

where  $|x_* - x| := \text{dist}(x, bD)$ . □

We now state a very useful result to prove Hölder estimates, popularly known as the Hardy–Littlewood lemma. For a proof the reader may refer to [Chen and Shaw 2001, p. 345].

**Lemma 2.3** (Hardy–Littlewood lemma). *Let  $D$  be a bounded domain in  $\mathbb{R}^N$  with  $C^1$  boundary. Suppose  $g \in C^k(\bar{D})$  and that for some  $0 < \beta < 1$  there is a constant  $C$  such that*

$$|D^{k+1} g(x)| \leq C \delta(x)^{-1+\beta}, \quad x \in D,$$

where  $\delta(x) = \text{dist}(x, bD)$ . Then  $g \in C^{k+\beta}(\bar{D})$ .

The following lemma can be found in [Bell 1993]. We provide the proof for the reader's convenience.

**Lemma 2.4.** *Let  $D$  be a bounded domain  $\Omega \subset \mathbb{C}^n$  and let  $B(z, w)$  and  $\mathcal{P}$  denote the Bergman kernel and the Bergman projection for  $D$ , respectively. Given  $w_0 \in D$ , there exists a function  $\phi_{w_0}$  in  $C_c^\infty(D)$  such that*

$$(2-5) \quad \frac{\partial^{|\beta|}}{\partial \bar{w}^\beta} B(z, w_0) = \mathcal{P} \phi_{w_0}^\beta(z), \quad \phi_{w_0}^\beta(z) := (-1)^{|\beta|} \frac{\partial^{|\beta|}}{\partial \bar{z}^\beta} \phi_{w_0}(z),$$

where  $\beta$  is a multiindex.

*Proof.* Let  $\delta_0$  denote the distance from  $w_0$  to  $bD$  and let  $B_1(\mathbf{0})$  the unit ball in  $\mathbb{C}^n$ . Set

$$\phi_{w_0}(z) = \delta_0^{-2n} \phi\left(\frac{z - w_0}{\delta_0}\right), \quad z \in D,$$

where  $\phi$  is a real-valued function in  $C_c^\infty(B_1(\mathbf{0}))$  that is radially symmetric about the origin and  $\int \phi \, dV = 1$ . Clearly,  $\phi_{w_0} \in C_c^\infty(D)$ . By the property of the Bergman projection and the Bergman kernel, we have

$$\begin{aligned} \mathcal{P}\phi_{w_0}(z) &= \int_D B(z, \zeta) \phi_{w_0}(\zeta) \, dV(\zeta) \\ &= \int_D B(z, \zeta) \delta_0^{-2n} \phi\left(\frac{\zeta - w_0}{\delta_0}\right) \, dV(\zeta) \\ &= \int_{B_1(\mathbf{0})} B(z, \delta_0 \zeta + w_0) \phi(\zeta) \, dV(\zeta) \\ &= \overline{\int_{B_1(\mathbf{0})} B(\delta_0 \zeta + w_0, z) \phi(\zeta) \, dV(\zeta)} \\ &= \overline{B(w_0, z)} \\ &= B(z, w_0), \end{aligned}$$

where we used the fact that  $B$  is holomorphic in the first argument and thus both its real and imaginary parts are harmonic functions which satisfy the mean value property. This proves (2-5) for  $\beta = 0$ . The general case follows similarly by repeating the above calculation and integration by parts. We leave the details to the reader. □

### 3. Estimates of the kernel

In this section we follow Ligocka’s idea to construct the kernel of the projection operator  $\mathcal{L}$  for a strictly pseudoconvex domain. For now we assume the defining function  $\rho$  is in the class  $C^3$ .

Suppose a bounded domain  $D \subset \mathbb{C}^n$  is given by  $D = \{z \in \mathbb{C}^n : \rho(z) < 0\}$ . We write

$$D_\delta := \{z \in \mathbb{C}^n : \rho(z) < \delta\}, \quad \delta > 0.$$

We shall sometimes write  $D_\delta(z)$  (or  $D_\delta(\zeta)$ ) to indicate that the domain is for the  $z$  (or  $\zeta$ ) variable. We now construct the kernel to be used in the integral formula. By setting  $\rho' = e^{A\rho} - 1$ , for some large  $A$ , we see that  $\rho'$  is strictly plurisubharmonic in a neighborhood of  $\bar{D}$ , and from now on we simply assume  $\rho$  satisfies this property.

Define

$$(3-1) \quad F(z, \zeta) = \sum_{j=1}^n \frac{\partial \rho}{\partial \bar{\zeta}_j}(\zeta)(\zeta_j - z_j) - \frac{1}{2} \sum_{i,j=1}^n \frac{\partial^2 \rho}{\partial \bar{\zeta}_i \partial \zeta_j}(\zeta)(z_i - \zeta_i)(z_j - \zeta_j).$$

By Taylor's formula we have

$$(3-2) \quad \rho(z) = \rho(\zeta) - 2 \operatorname{Re} F(z, \zeta) + \mathcal{L}_\rho(\zeta; z - \zeta) + o(|z - \zeta|^2),$$

where  $\mathcal{L}_\rho(\zeta; t)$  is the Levi form of  $\rho$  at  $\zeta$ , i.e.,  $\mathcal{L}_\rho(\zeta; t) := \sum_{i,j=1}^n \partial^2 \rho / (\partial \bar{\zeta}_i \partial \zeta_j) t_i \bar{t}_j$ . Fix some  $\varepsilon_0 > 0$  small such that for all  $z, \zeta \in D_\delta$ , we have  $\mathcal{L}_\rho(\zeta; z - \zeta) \geq c|z - \zeta|^2$ . It follows from (3-2) that (for  $(z, \zeta) \in D_\delta \times D_\delta, |z - \zeta| < \varepsilon_0$ )

$$(3-3) \quad \operatorname{Re} F(z, \zeta) \geq \frac{\rho(\zeta) - \rho(z)}{2} + \frac{c}{2}|z - \zeta|^2,$$

$$(3-4) \quad \operatorname{Re} F(z, \zeta) - \rho(\zeta) \geq -\frac{\rho(\zeta) + \rho(z)}{2} + \frac{c}{2}|z - \zeta|^2.$$

Let  $\chi(t)$  be a smooth cut-off function such that  $\chi(t) \equiv 1$  if  $t < \varepsilon_0/4$  and  $\chi(t) \equiv 0$  if  $t > \varepsilon_0/2$ . We define the following global support function:

$$(3-5) \quad G(z, \zeta) = \chi(t)F(z, \zeta) + (1 - \chi(t))|z - \zeta|^2, \quad t = |z - \zeta|.$$

We also define the vector-valued functions  $g_0 = (g_0^1, \dots, g_0^n)$  and  $g_1 = (g_1^1, \dots, g_1^n)$ , where

$$g_0^i(z, \zeta) = \overline{\zeta_i - z_i}, \quad 1 \leq i \leq n,$$

and (for  $1 \leq i \leq n$ ),

$$(3-6) \quad g_1^i(z, \zeta) = \chi(t) \left( \sum_{j=1}^n \frac{\partial \rho}{\partial \bar{\zeta}_j}(\zeta) + \frac{1}{2} \sum_{j=1}^n \frac{\partial^2 \rho}{\partial \bar{\zeta}_i \partial \zeta_j}(\zeta)(z_j - \zeta_j) \right) + (1 - \chi(t)) \overline{(\zeta_i - z_i)},$$

where  $t = |z - \zeta|$ . It follows that  $\langle g_0, \zeta - z \rangle = |\zeta - z|^2$  and  $\langle g_1, \zeta - z \rangle = G(z, \zeta)$ . In view of (3-4) and (3-5), there exists some  $c > 0$  such that

$$(3-7) \quad \operatorname{Re} G(z, \zeta) - \rho(\zeta) \geq c(-\rho(\zeta) - \rho(z) + |z - \zeta|^2), \quad z, \zeta \in \bar{D},$$

and

$$(3-8) \quad \operatorname{Re} G(z, \zeta) - \rho(\zeta) \geq \frac{1}{4}[-\rho(\zeta) - \rho(z)] + c|z - \zeta|^2, \quad z, \zeta \in D_\delta \times D_\delta.$$

In particular, (3-7) implies

$$(3-9) \quad |G(z, \zeta) - \rho(\zeta)| \gtrsim |z - \zeta|^2, \quad z, \zeta \in D.$$

We note that if the boundary is  $C^{k+3+\alpha}$ , then  $g_1, G \in C^\infty \times C^{k+1+\alpha}(D_\delta(z) \times D_\delta(\zeta))$  and holomorphic in  $z$  whenever  $|z - \zeta| < \varepsilon_0/4$ . Let

$$\omega_\lambda(z, \zeta) = \frac{1}{2\pi\sqrt{-1}} \frac{\langle g_\lambda(z, \zeta), d\zeta \rangle}{\langle g_\lambda, \zeta - z \rangle}, \quad \lambda = 0, 1.$$

The associated Cauchy–Fantappie forms are given by

$$\begin{aligned} \Omega^\lambda &= \omega_\lambda \wedge (\bar{\partial}_{z,\zeta} \omega_\lambda)^{n-1}, & \lambda = 0, 1. \\ \Omega^{01} &= \omega_0 \wedge \omega_1 \wedge \sum_{k_1+k_2=n-2} (\bar{\partial}_{z,\zeta} \omega_0)^{k_1} \wedge (\bar{\partial}_{z,\zeta} \omega_1)^{k_2}. \end{aligned}$$

We decompose  $\Omega^\lambda = \sum_{0 \leq q \leq n} \Omega_{0,q}^\lambda$  and  $\Omega^{01} = \sum_{0 \leq q \leq n} \Omega_{0,q}^{01}$ , where  $\Omega_{0,q}^\lambda$  (resp.  $\Omega_{0,q}^{01}$ ) has type  $(0, q)$  in  $z$  and type  $(n, n-1-q)$  type in  $\zeta$ . The following Koppelman's formula holds:

$$(3-10) \quad \bar{\partial}_\zeta \Omega_{0,q}^{01} + \bar{\partial}_z \Omega_{0,q-1}^{01} = \Omega_{0,q}^0 - \Omega_{0,q}^1,$$

where we take  $\Omega_{0,-1}^{01} \equiv 0$ . Write (for  $\lambda = 0, 1$ )

$$(3-11) \quad \begin{aligned} \Omega_{0,0}^\lambda(z, \zeta) &= \frac{1}{(2\pi\sqrt{-1})^n} \frac{1}{\langle g_\lambda, \zeta - z \rangle^n} \left( \sum_{i=1}^n g_\lambda^i d\zeta_i \right) \wedge \left( \sum_{i,j=1}^n \bar{\partial}_\zeta g_\lambda^i \wedge d\zeta_j \right)^{n-1}; \end{aligned}$$

$$(3-12) \quad \begin{aligned} \Omega_{0,0}^{01}(z, \zeta) &= \frac{1}{(2\pi\sqrt{-1})^n} \frac{\langle \bar{\zeta} - z, d\zeta \rangle}{|\zeta - z|^2} \wedge \frac{\langle g_1, d\zeta \rangle}{\langle g_1, \zeta - z \rangle} \wedge \sum_{k_1+k_2=n-2} \left( \frac{\langle d\bar{\zeta}, d\zeta \rangle}{|\zeta - z|^2} \right)^{k_1} \\ &\quad \wedge \left( \frac{\langle \bar{\partial}_\zeta g_1, d\zeta \rangle}{\langle g_1, \zeta - z \rangle} \right)^{k_2}. \end{aligned}$$

Define

$$(3-13) \quad \begin{aligned} N(z, \zeta) &:= \frac{1}{(2\pi\sqrt{-1})^n} \frac{1}{[G(z, \zeta) - \rho(\zeta)]^n} \left( \sum_{i=1}^n g_1^i(z, \zeta) d\zeta_i \right) \\ &\quad \wedge \left( \sum_{i=1}^n \bar{\partial}_\zeta g_1^i(z, \zeta) \wedge d\zeta_i \right)^{n-1} \\ &= C_n \sum_{i=1}^n (-1)^{i-1} \frac{g_1^i(z, \zeta)}{[G(z, \zeta) - \rho(\zeta)]^n} d\zeta \wedge (\bar{\partial}_\zeta g_1^i) \wedge \cdots \\ &\quad \wedge \widehat{(\bar{\partial}_\zeta g_1^i)} \wedge \cdots \wedge (\bar{\partial}_\zeta g_n), \end{aligned}$$

where  $\widehat{\eta}$  means  $\eta$  is being excluded. Note that for  $\zeta \in bD$ , we have  $N(z, \zeta) = \Omega_{0,0}^1(z, \zeta)$ . Therefore by (3-10) with  $q = 0$ ,

$$(3-14) \quad \Omega_{0,0}^0(z, \zeta) = \bar{\partial}_\zeta \Omega_{0,0}^{01}(z, \zeta) + N(z, \zeta), \quad z \in D_{\varepsilon_0}, \zeta \in bD.$$

Let

$$(3-15) \quad L(z, \zeta)dV(\zeta) := \bar{\partial}_\zeta N(z, \zeta) - S_z(\bar{\partial}_z \bar{\partial}_\zeta N)(z, \zeta),$$

where  $S_z$  is Hörmander’s operator that solves  $\bar{\partial}$  on  $D_\delta$ . In what follows we write  $L = L_0 + L_1$ , where

$$L_0 dV(\zeta) = -S_z(\bar{\partial}_z \bar{\partial}_\zeta N)(z, \zeta), \quad L_1 dV(\zeta) = \bar{\partial}_\zeta N(z, \zeta).$$

For each  $\zeta \in \bar{D}$ ,  $L(\cdot, \zeta)$  is holomorphic on  $D$ . We also note that if  $bD \in C^{k+3+\alpha}$ , then  $\bar{\partial}_\zeta N \in C^\infty \times C^{k+\alpha}(D(z) \times D(\zeta))$ . In view of (3-8), (3-13) and the fact that  $\bar{\partial}_z G(z, \zeta), \bar{\partial}_z g(z, \zeta) \equiv 0$  for  $|z - \zeta| < \varepsilon_0/4$ , we see that  $\bar{\partial}_z \bar{\partial}_\zeta N(z, \zeta)$  is a well-defined  $\bar{\partial}$ -closed  $(0, 1)$  form with coefficients in  $C^\infty \times C^{k+\alpha}(D_\delta(z) \times D_\delta(\zeta))$ , if  $\delta > 0$  is sufficiently small. Write

$$(3-16) \quad \begin{aligned} \bar{\partial}_\zeta N(z, \zeta) &= L_1(z, \zeta)dV(\zeta) \\ &= C_n \frac{\bar{\partial}_\zeta [G(z, \zeta) - \rho(\zeta)]}{[G(z, \zeta) - \rho(\zeta)]^{n+1}} \\ &\quad \times \sum_{i=1}^n (-1)^{i-1} g_1^i(z, \zeta) d\zeta \wedge (\bar{\partial}_\zeta g_1^1) \wedge \cdots \wedge \widehat{(\bar{\partial}_\zeta g_1^i)} \wedge \cdots \wedge (\bar{\partial}_\zeta g_1^n) \\ &\quad + \frac{1}{[G(z, \zeta) - \rho(\zeta)]^n} d\zeta \wedge (\bar{\partial}_\zeta g_1^1) \wedge \cdots \wedge (\bar{\partial}_\zeta g_1^n). \end{aligned}$$

In the proof we shall use the following convenient expression from [Ligocka 1984]:

$$(3-17) \quad L_1(z, \zeta) = \frac{\eta(\zeta) + O'(|z - \zeta|)}{[G(z, \zeta) - \rho(\zeta)]^{n+1}}, \quad \eta(\zeta) := c_n \det \begin{vmatrix} \rho(\zeta) & \frac{\partial \rho}{\partial \bar{\zeta}_i}(\zeta) \\ \frac{\partial \rho}{\partial \bar{\zeta}_i}(\zeta) & \frac{\partial^2 \rho}{\partial \bar{\zeta}_i \partial \bar{\zeta}_j}(\zeta) \end{vmatrix}.$$

Here we note that  $\overline{\eta(\zeta)} = \eta(\zeta)$ , and  $O'(|z - \zeta|)$  is some linear combination of products of  $[\widehat{D^3 \rho}(\zeta)](\zeta_i - z_i)$ , where  $[\widehat{D^3 \rho}(\zeta)]$  denotes products of  $\rho(\zeta)$  and  $D_\zeta^k \rho(\zeta)$ ,  $k \leq 3$ . In particular, for  $l \geq 1$ ,  $O'(|z - \zeta|)$  satisfies the estimates

$$(3-18) \quad \begin{aligned} |O'(|z - \zeta|)| &\lesssim |\rho|_3 |\zeta - z|, \\ |D_z^l O'(|z - \zeta|)| &\lesssim |\rho|_3, \\ |D_\zeta^l O'(|z - \zeta|)| &\lesssim |\rho|_{l+2} + |\rho|_{l+3} |\zeta - z|. \end{aligned}$$

We now define the integral operator

$$(3-19) \quad \mathcal{L}f(z) := \int_D L(z, \zeta)f(\zeta) dV(\zeta) = \int_D [L_0(z, \zeta) + L_1(z, \zeta)]f(\zeta) dV(\zeta),$$

and the associated adjoint operator

$$\mathcal{L}^* f(z) := \int_D \overline{L(\zeta, z)}f(\zeta) dV(\zeta) = \int_D [\overline{L_0(\zeta, z)} + \overline{L_1(\zeta, z)}]f(\zeta) dV(\zeta).$$



In the same way as (3-17), we can also write

$$(3-20) \quad \overline{L_1(\zeta, z)} = \frac{\eta(z) + O''(|z - \zeta|)}{[\overline{G(\zeta, z)} - \rho(z)]^{n+1}}, \quad \eta(z) := c_n \det \begin{vmatrix} \rho(z) & \frac{\partial \rho}{\partial \bar{z}_i}(z) \\ \frac{\partial \rho}{\partial \bar{z}_i}(z) & \frac{\partial^2 \rho}{\partial \bar{z}_i \partial \bar{z}_j}(z) \end{vmatrix}.$$

Here  $O''(|z - \zeta|)$  is some linear combination of products of  $[\widehat{D^3} \rho(z)](\zeta_i - z_i)$ , where  $[\widehat{D^3} \rho(z)]$  denotes products of  $\rho(z)$  and  $D_z^k \rho(z)$ ,  $k \leq 3$ . For  $l \geq 1$ ,  $O''(|z - \zeta|)$  satisfies the estimate

$$(3-21) \quad \begin{aligned} |O''(|z - \zeta|)| &\lesssim |\rho|_3 |\zeta - z|, \\ |D_\zeta^l O''(|z - \zeta|)| &\lesssim |\rho|_3, \\ |D_z^l O''(|z - \zeta|)| &\lesssim |\rho|_{l+2} + |\rho|_{l+3} |\zeta - z|. \end{aligned}$$

Hence if  $bD \in C^{k+3+\alpha}$ , then  $\overline{L_1(\zeta, z)}$  is  $C^{k+\alpha} \times C^\infty(D(z) \times D(\zeta))$ .

Let

$$(3-22) \quad K(z, \zeta) := \overline{L(\zeta, z)} - L(z, \zeta) = [\overline{L_0(\zeta, z)} - L_0(z, \zeta)] + [\overline{L_1(\zeta, z)} - L_1(z, \zeta)],$$

and

$$(3-23) \quad \begin{aligned} \mathcal{K}f(z) &:= \int_D K(z, \zeta) f(\zeta) dV(\zeta) \\ &= \int [\overline{L(\zeta, z)} - L(z, \zeta)] f(\zeta) dV(\zeta) \\ &= \mathcal{L}^* f(z) - \mathcal{L}f(z). \end{aligned}$$

For later purpose we note that  $\sqrt{-1}\mathcal{K}$  is a self-adjoint operator.

The following cancellation estimate is due to [Kerzman and Stein 1978]. We include a proof here for the reader's convenience.

**Proposition 3.1.** *Let  $D$  be a strictly pseudoconvex domain with a  $C^3$  defining function  $\rho$ , with  $0 < \alpha < 1$ . Let  $F(z, \zeta)$  be the function defined by formula (3-1). Then*

$$(3-24) \quad [F(z, \zeta) - \rho(\zeta)] - [\overline{F(\zeta, z)} - \rho(z)] = O(|\zeta - z|^3),$$

where  $|O(|\zeta - z|^3)| \lesssim |\rho|_3 |\zeta - z|^3$ .

*Proof.* By (3-1) we have

$$\begin{aligned}
 F(z, \zeta) &= \sum_{j=1}^n \frac{\partial \rho}{\partial \zeta_j}(\zeta)(\zeta_j - z_j) - \frac{1}{2} \sum_{i,j=1}^n \frac{\partial^2 \rho}{\partial \zeta_i \partial \zeta_j}(\zeta)(z_i - \zeta_i)(z_j - \zeta_j) \\
 &= \sum_{j=1}^n \left[ \frac{\partial \rho}{\partial z_j}(z) + \sum_{k=1}^n \frac{\partial^2 \rho}{\partial z_j \partial z_k}(z)(\zeta_k - z_k) + \sum_{k=1}^n \frac{\partial^2 \rho}{\partial z_j \partial \bar{z}_k}(z)(\overline{\zeta_k - z_k}) \right] (\zeta_j - z_j) \\
 &\quad - \sum_{i,j=1}^n \frac{1}{2} \frac{\partial^2 \rho}{\partial z_i \partial z_j}(z)(z_i - \zeta_i)(z_j - \zeta_j) + R(z, \zeta) \\
 &= \sum_{j=1}^n \frac{\partial \rho}{\partial z_j}(z)(\zeta_j - z_j) + \frac{1}{2} \sum_{i,j=1}^n \frac{\partial^2 \rho}{\partial z_i \partial z_j}(z)(\zeta_i - z_i)(\zeta_j - z_j) \\
 &\quad + \sum_{i,j=1}^n \frac{\partial^2 \rho}{\partial z_i \partial \bar{z}_j}(z)(\zeta_i - z_i)(\overline{\zeta_j - z_j}) + R_0(z, \zeta),
 \end{aligned}$$

where we did Taylor expansion for the function  $\frac{\partial \rho}{\partial \zeta_j}$  at  $z$ . Since  $\rho \in C^3$ , the remainder term  $R_0$  satisfies  $|R_0(z, \zeta)| \lesssim |\rho|_3 |\zeta - z|^3$ . On the other hand,

$$\overline{F(\zeta, z)} = \sum_{j=1}^n \frac{\partial \rho}{\partial \bar{z}_j}(z)(\overline{z_j - \zeta_j}) - \frac{1}{2} \sum_{i,j=1}^n \frac{\partial^2 \rho}{\partial \bar{z}_i \partial \bar{z}_j}(z)(\overline{\zeta_i - z_i})(\overline{\zeta_j - z_j}).$$

Hence

$$\begin{aligned}
 F(z, \zeta) - \overline{F(\zeta, z)} &= \sum_{j=1}^n \frac{\partial \rho}{\partial z_j}(z)(\zeta_j - z_j) + \sum_{j=1}^n \frac{\partial \rho}{\partial \bar{z}_j}(z)(\overline{\zeta_j - z_j}) \\
 &\quad + \operatorname{Re} \left( \sum_{i,j=1}^n \frac{\partial^2 \rho}{\partial z_i \partial z_j}(z)(\zeta_i - z_i)(\zeta_j - z_j) \right) \\
 &\quad + \sum_{i,j=1}^n \frac{\partial^2 \rho}{\partial z_i \partial \bar{z}_j}(z)(\zeta_i - z_i)(\overline{\zeta_j - z_j}) + R_0(z, \zeta),
 \end{aligned}$$

where  $|R_0(z, \zeta)| \lesssim |\rho|_3 |\zeta - z|^3$ . The first four terms on the right-hand side are exactly the first and second order terms in the Taylor polynomial of  $\rho$  at  $z$ , which is equal to  $\rho(\zeta) - \rho(z) + R_1(z, \zeta)$ , where  $|R_1(z, \zeta)| \lesssim |\rho|_3 |\zeta - z|^3$ . Hence

$$F(z, \zeta) - \overline{F(\zeta, z)} = \rho(\zeta) - \rho(z) + R(z, \zeta),$$

where  $|R(z, \zeta)| \lesssim |\rho|_3 |\zeta - z|^3$ . □

In what follows we shall denote

$$\Phi(z, \zeta) = G(z, \zeta) - \rho(\zeta), \quad \bar{\Phi}(\zeta, z) = \overline{G(\zeta, z)} - \rho(z).$$

**Lemma 3.2.** *Let  $D$  be a bounded strictly pseudoconvex domain with  $C^3$  boundary in  $\mathbb{C}^n$ ,  $n \geq 2$ . Let  $\rho$  be the defining function of  $D$ . Let  $0 < \beta \leq 1$ . Let  $\Theta(z, \zeta)$  denote either  $\Phi(z, \zeta)$  or  $\Phi(\zeta, z)$ :*

(i) *Let  $0 < \beta \leq 1$ . Then*

$$(3-25) \quad \int_D \frac{dV(\zeta)}{|\zeta - z|^{2-\beta} |\Theta(z, \zeta)|^{n+1}} \lesssim 1 + \delta(z)^{\beta/2-1},$$

*where the constant depends only on  $D$ .*

(ii) *Let  $\beta > 0$ . Then*

$$(3-26) \quad \int_{B(z, \tau)} \frac{|z - \zeta|^\beta}{|\Theta(z, \zeta)|^{n+1}} dV(\zeta) \lesssim \tau^{\beta/2},$$

*where the constant depends only on  $D$ .*

*Proof.* First, we show that for each fixed  $z \in D$ , there exists a small neighborhood  $U_z$  and a coordinate chart  $\phi_z : U_z \rightarrow \mathbb{R}^{2n}$  with  $\phi_z(\zeta) = ((s_1, s_2), t) \in \mathbb{R}^2 \times \mathbb{R}^{2n-2}$  and

$$(3-27) \quad |\Phi(z, \zeta)|, |\Phi(\zeta, z)| \gtrsim \delta(z) + |s_1| + |s_2| + |t|^2, \quad |\zeta - z| \gtrsim |(s_2, t)|.$$

Here  $\delta(z) := \text{dist}(z, bD)$  and in the following computation we shall just write  $\delta$ . We define  $s_1(\zeta) = \rho(\zeta)$  and  $s_2(\zeta) = \text{Im } \Phi(z, \zeta)$ . Recall that  $\Phi(z, \zeta) = F(z, \zeta) - \rho(\zeta)$  when  $z, \zeta$  are close and

$$F(z, \zeta) = \sum_{j=1}^n \frac{\partial \rho}{\partial \zeta_j}(\zeta) (\zeta_j - z_j) + O(|\zeta - z|^2).$$

Hence at  $\zeta = z$ , we have

$$\begin{aligned} d_\zeta \text{Im } \Phi(z, \zeta) \wedge d_\zeta \rho(\zeta) &= d_\zeta \text{Im } F(z, \zeta) \wedge d_\zeta \rho(\zeta) \\ &= \frac{1}{2\sqrt{-1}} (\partial_\zeta \rho - \bar{\partial}_\zeta \rho) \wedge (\partial_\zeta \rho + \bar{\partial}_\zeta \rho) \\ &= \frac{1}{\sqrt{-1}} \partial \rho \wedge \bar{\partial} \rho \neq 0. \end{aligned}$$

We can then find smooth real-valued functions  $t_j$ ,  $1 \leq j \leq 2n-2$ , with  $t_j(\zeta) = 0$  at  $\zeta = z$  and

$$d_\zeta \rho(\zeta) \wedge d_\zeta \text{Im } \Phi(z, \zeta) \wedge dt_1(\zeta) \wedge \cdots \wedge dt_{2n-2}(\zeta) \neq 0 \quad \text{at } \zeta = z.$$

By the inverse function theorem,  $\phi_z = (s_1, s_2, t)$  defines a  $C^1$  coordinate map in small neighborhood of  $z$ .

To prove the first statement in (3-27), we use estimate (3-7) which says that  $\operatorname{Re} \Phi(z, \zeta) \gtrsim -\rho(\zeta) - \rho(z) + |\zeta - z|^2$ , for all  $z, \zeta \in D$ . It follows that

$$|\Phi(z, \zeta)| \gtrsim |\operatorname{Re} \Phi(z, \zeta)| + |\operatorname{Im} \Phi(z, \zeta)| \gtrsim \delta(z) + |s_1(\zeta)| + |s_2(\zeta)| + |t(\zeta)|^2.$$

For  $\Phi(\zeta, z)$  the argument goes the same: We note that  $\Phi(\zeta, z) = F(\zeta, z) - \rho(z)$  when  $z, \zeta$  are close, and

$$F(\zeta, z) = \sum_{j=1}^n \frac{\partial \rho}{\partial z_j}(z)(z_j - \zeta_j) + O(|\zeta - z|^2).$$

Thus at  $\zeta = z$ ,

$$\begin{aligned} d_\zeta \operatorname{Im} \Phi(\zeta, z) \wedge d_\zeta \rho(\zeta) \Big|_{\zeta=z} &= d_\zeta \operatorname{Im} F(\zeta, z) \wedge d_z \rho(z) \\ &= \frac{1}{2\sqrt{-1}} (\bar{\partial}_z \rho(z) - \partial_z \rho(z)) \wedge (\partial_z \rho(z) + \bar{\partial}_z \rho(z)) \\ &= \frac{1}{\sqrt{-1}} \bar{\partial} \rho \wedge \partial \rho \\ &\neq 0. \end{aligned}$$

The second statement in (3-27) follows from the fact that  $s_2(z) = t(z) = 0$ . Now, both  $\Phi(z, \zeta)$  and  $|\zeta - z|$  are bounded below by some positive constant for  $\zeta \notin \mathcal{U}_z$ . Hence using partition of unity in  $\zeta$  space, we can bound the integral on the left-hand side of (3-25) by a constant times

$$\int_0^1 \int_0^1 \int_0^1 \frac{t^{2n-3} ds_1 ds_2 dt}{(s_2 + t)^{2-\beta} (\delta + s_1 + s_2 + t^2)^{n+1}} \lesssim \int_0^1 \int_0^1 \frac{r t^{2n-5+\beta} dr dt}{(\delta + r + t^2)^{n+1}} := I,$$

where we used the polar coordinates for  $(s_1, s_2)$  with  $r = |s|$ . We can estimate the integral  $I$  by separating into different cases.

Case 1:  $\delta > r, t^2$ .

$$\begin{aligned} I &\leq \delta^{-(n+1)} \left( \int_0^\delta r dr \right) \left( \int_0^{\sqrt{\delta}} t^{2n-5+\beta} dt \right) \\ &\lesssim 1 + \delta^{-n-1+2+(2n-4+\beta)/2} \\ &= 1 + \delta^{-1+\beta/2}. \end{aligned}$$

Case 2:  $r > \delta, t^2$ .

$$\begin{aligned} I &\leq \int_\delta^1 r^{-n} \left( \int_0^{\sqrt{r}} t^{2n-5+\beta} dt \right) dr \\ &\lesssim \int_\delta^1 r^{-n+(2n-4+\beta)/2} dr \\ &\lesssim 1 + \delta^{-1+\beta/2}. \end{aligned}$$

Case 3:  $t^2 > \delta, r$ .

$$\begin{aligned}
I &\leq \int_{\sqrt{\delta}}^1 \left( \int_0^{t^2} r \, dr \right) t^{2n-5+\beta-2n-2} \, dt \\
&\lesssim \int_{\sqrt{\delta}}^1 t^{\beta-3} \, dt \\
&\lesssim 1 + \delta^{-1+\beta/2}.
\end{aligned}$$

Combining the estimates we obtain (3-25).

(ii) Since  $|\Theta(z, \zeta)| \gtrsim |z - \zeta|^2$ , the integral is bounded by

$$\begin{aligned}
\int_{B_\tau(z)} \frac{|z - \zeta|^\beta}{|\Theta(z, \zeta)|^{n+1}} dV(\zeta) &\leq \int_{B_\tau(z)} \frac{dV(\zeta)}{|z - \zeta|^{2-\beta} |\Theta(z, \zeta)|^n} \\
&\lesssim \int_0^1 \int_0^1 \int_0^1 \frac{t^{2n-3} \, ds_1 \, ds_2 \, dt}{(s_2 + t)^{2-\beta} (\delta + s_1 + s_2 + t^2)^n} \\
&\lesssim \int_{s_1=0}^1 \int_{s_2=0}^\tau \int_{t=0}^\tau \frac{t^{2n-5+\beta} \, ds_1 \, ds_2 \, dt}{(s_1 + s_2 + t^2)^n} \\
&:= I.
\end{aligned}$$

Here we used the fact that  $|\zeta - z| \gtrsim (s_2, t)$  and thus  $\zeta \in B_\tau(z)$  implies  $|s_2|, |t| < \tau$ .

We consider several cases.

Case 1:  $s_1 > \tau$ . The integral is bounded by

$$I \leq \int_\tau^1 \frac{ds_1}{s_1^n} \int_0^\tau ds_2 \int_0^\tau t^{2n-5+\beta} \, dt \lesssim \tau^{-n+1+1+2n-4+\beta} = \tau^{n-2+\beta} \lesssim \tau^\beta.$$

Case 2:  $s_1 < \tau$ . Then we have  $|s| < r$ , for  $s = (s_1, s_2)$ . Divide further into subcases. If  $t^2 > s$ , then

$$I \lesssim \int_0^\tau \int_0^\tau \frac{st^{2n-5+\beta} \, ds \, dt}{(s + t^2)^n} \leq \int_0^\tau \left( \int_0^{t^2} s \, ds \right) t^{2n-5+\beta-2n} \, dt \lesssim \int_0^\tau t^{\beta-1} \, dt \lesssim \tau^\beta.$$

On the other hand, if  $t^2 < s$ , then

$$\begin{aligned}
I &\lesssim \int_0^\tau \left( \int_0^{\sqrt{s}} t^{2n-3-2+\beta} \, dt \right) \frac{s}{s^n} \, ds \\
&\lesssim \int_0^\tau s^{\frac{2n-4+\beta}{2}-n+1} \, ds \\
&\lesssim \int_0^\tau s^{\beta/2-1} \, ds \\
&\lesssim \tau^{\beta/2}. \quad \square
\end{aligned}$$

From the proof of Lemma 3.2, we see that for fixed  $\zeta$ , we can find a neighborhood  $U_\zeta$  of  $\zeta$  and a coordinate chart  $\phi_\zeta : U_\zeta \rightarrow \mathbb{R}^{2n}$  with  $\phi_\zeta(z) = (s'_1, s'_2, t') \in \mathbb{R} \times \mathbb{R} \times \mathbb{R}^{2n-2}$ .

Indeed, we can set  $s'_1(z) = \rho(z)$  and  $s'_2(z) = \text{Im } \Phi(z, \zeta)$ . At  $z = \zeta$ ,

$$\begin{aligned} d_z \text{Im } \Phi(z, \zeta) \wedge d_z \rho(z) &= d_z \text{Im } F(z, \zeta) \wedge d_z \rho(z) \\ &= \frac{1}{2\sqrt{-1}} (\bar{\partial}_\zeta \rho(\zeta) - \partial_\zeta \rho(\zeta)) \wedge (\partial_\zeta \rho(\zeta) + \bar{\partial}_\zeta \rho(\zeta)) \\ &= \frac{1}{\sqrt{-1}} \bar{\partial} \rho(\zeta) \wedge \partial \rho(\zeta) \\ &\neq 0. \end{aligned}$$

Hence there exists smooth real-valued functions  $t'_j$ ,  $1 \leq j \leq 2n-2$  with  $t'_j(z) = 0$  and

$$d_z \rho(z) \wedge d_z \text{Im } \Phi(z, \zeta) \wedge dt'_1(\zeta) \wedge \cdots \wedge dt'_{2n-2}(\zeta) \neq 0 \quad \text{at } z = \zeta.$$

Consequently  $(s'_1, s'_2, t')$  is the desired coordinate chart in the  $z$  variable. Now by the same estimate as in the proof of [Lemma 3.2](#), we can prove the following:

**Lemma 3.3.** *Keeping the assumptions of [Lemma 3.2](#):*

(i) *Let  $0 < \beta \leq 1$ . Then*

$$(3-28) \quad \int_D \frac{dV(z)}{|\zeta - z|^{2-\beta} |\Theta(z, \zeta)|^{n+1}} \lesssim 1 + \delta(\zeta)^{\beta/2-1}, \quad \delta(\zeta) := \text{dist}(\zeta, bD),$$

*where the constant depends only on  $D$ .*

(ii) *Let  $\beta > 0$ , and denote by  $B_\tau(z)$  the ball of radius  $\tau$  centered at  $z$ . Then*

$$(3-29) \quad \int_{B_\tau(z)} \frac{|z - \zeta|^\beta}{|\Theta(z, \zeta)|^{n+1}} dV(z) \lesssim \tau^{\beta/2},$$

*where the constant depends only on  $D$ .*

**Lemma 3.4.** *Let  $D$  be a bounded strictly pseudoconvex domain with  $C^3$  boundary in  $\mathbb{C}^n$ ,  $n \geq 2$ , and let  $\rho$  be its defining function. Let  $\Theta(z, \zeta)$  denote either  $\Phi(z, \zeta)$  or  $\Phi(\zeta, z)$ . Denote  $\delta(z) := \text{dist}(z, bD)$ :*

(i) *For  $z \in D$ ,*

$$(3-30) \quad \int_D \frac{dV(\zeta)}{|\Theta(z, \zeta)|^{n+1}} \lesssim 1 + \log \delta(z),$$

*where the constant depends only on  $D$ .*

(ii) *For  $z \in D$ ,*

$$(3-31) \quad \int_{bD} \frac{d\sigma(\zeta)}{|\Theta(z, \zeta)|^n} \lesssim 1 + \log \delta(z),$$

*where the constant depends only on  $D$ .*

*Proof.* (i) In the proof we shall write  $\delta(z)$  simply as  $\delta$ . For fixed  $z \in D$ , let  $\zeta \mapsto (s_1, s_2, t)$  be the coordinate chart in a neighborhood  $U_z$  of  $z$  as constructed in the proof of Lemma 3.2. Let  $\chi_0$  be a smooth cut-off function such that  $\text{supp } \chi_0 \subset E_0(z) := \{\zeta \in D : -\rho(\zeta) - \rho(z) + |z - \zeta| \leq \sigma\}$  and  $\chi_0 \equiv 1$  on the set  $E_1(z) := \{\zeta \in D : -\rho(\zeta) - \rho(z) + |z - \zeta| \leq \frac{\sigma}{2}\}$ . We choose  $\sigma$  sufficiently small such that  $E_0(z) \subset U_z$ . Then

$$\int_D \frac{dV(\zeta)}{|\Theta(z, \zeta)|^{n+1}} = \int_{D \cap E_0} \frac{\chi_0(\zeta) dV(\zeta)}{|\Theta(z, \zeta)|^{n+1}} + \int_{D \setminus E_1} \frac{(1 - \chi_0(\zeta)) dV(\zeta)}{|\Theta(z, \zeta)|^{n+1}}.$$

In view of (3-7), the second integral is bounded by a constant independent of  $z \in D$ .

The first integral is bounded by

$$\begin{aligned} \int_{D \cap E_0(z)} \frac{dV(\zeta)}{|\Theta(z, \zeta)|^{n+1}} &\lesssim \int_0^1 \int_0^1 \int_0^1 \frac{t^{2n-3} ds_1 ds_2 dt}{(\delta + s_1 + s_2 + t^2)^{n+1}} \\ &\lesssim \int_0^1 \int_0^1 \frac{t^{2n-3} r dr dt}{(\delta + r + t^2)^{n+1}} \\ &:= I, \end{aligned}$$

where we used the polar coordinates for  $r = (s_1, s_2)$ . We split the integral into the following cases:

Case 1:  $\delta + r \geq t^2$ .

$$\begin{aligned} I &\lesssim \int_0^1 \frac{r}{(\delta + r)^{n+1}} \left( \int_0^{\sqrt{\delta+r}} t^{2n-3} dt \right) dr \\ &\lesssim \int_0^1 (\delta + r)^{1-n-1+(2n-2)/2} dr \\ &= \int_0^1 (\delta + r)^{-1} dr \lesssim 1 + \log \delta. \end{aligned}$$

Case 2:  $\delta + r \leq t^2$ .

$$I \lesssim \int_0^1 r \left( \int_{\sqrt{\delta+r}}^1 \frac{t^{2n-3} dt}{t^{2n+2}} \right) dr \lesssim \int_0^1 (\delta + r)^{-1} dr \lesssim 1 + \log \delta.$$

(ii) Since  $s_1(\zeta) = \rho(\zeta) \equiv 0$  for  $\zeta \in bD$ , for fixed  $z$ , there exists some neighborhood  $U_z$  of  $z$  such that  $\zeta \mapsto (s_2, t)$  is a coordinate chart for  $\zeta \in bD \cap U_z$ . Let  $\chi_0, E_0$  be the same as in the proof of (i). We only have to estimate

$$\int_{bD \cap E_0} \frac{\chi_0 d\sigma(\zeta)}{|\Theta(z, \zeta)|^n} \lesssim \int_0^1 \int_0^1 \int_0^1 \frac{t^{2n-3} ds_2 dt}{(\delta + s_2 + t^2)^n} := I.$$

Split the integral into two cases.

$$\begin{aligned}
\text{Case 1: } \delta + s_2 \geq t^2. \quad I &\lesssim \int_0^1 \frac{1}{(\delta + s_2)^n} \left( \int_0^{\sqrt{\delta + s_2}} t^{2n-3} dt \right) ds_2 \\
&\lesssim \int_0^1 (\delta + s_2)^{-1} ds_2 \\
&\lesssim 1 + \log \delta.
\end{aligned}$$

$$\text{Case 2: } \delta + s_2 \leq t^2. \quad I \lesssim \int_0^1 \left( \int_{\sqrt{\delta + s_2}}^1 \frac{t^{2n-3} dt}{t^{2n}} \right) ds_2 \lesssim \int_0^1 (\delta + s_2)^{-1} ds_2 \lesssim 1 + \log \delta.$$

□

We now prove the  $L^2$  boundedness of the operator  $\mathcal{K}$ , assuming boundary is only  $C^3$ . This result is stated in [Ligocka 1984] assuming the boundary is  $C^4$ , and the proof over there uses a much more general estimate from [Krantz 1976]. We shall instead give a direct proof here.

**Proposition 3.5.** *Let  $D$  be a strictly pseudoconvex domain in  $\mathbb{C}^n$  with  $C^3$  boundary, and let  $\mathcal{K}$  be the operator given by formula (3-23). Then  $\mathcal{K}$  defines a bounded operator from  $L^2(D)$  to  $L^2(D)$ .*

*Proof.* We shall apply Schur's test (see for example [Wolff 2003]), which in our case can be formulated as follows. If

$$(3-32) \quad \int_D |K(z, \zeta)| dV(\zeta) \leq A, \quad \text{for each } z,$$

and

$$(3-33) \quad \int_D |K(z, \zeta)| dV(z) \leq B, \quad \text{for each } \zeta,$$

then for  $f \in L^2(D)$ ,  $\mathcal{K}_f$  defined by the integral  $\int_D K(z, \zeta) f(\zeta) dV(\zeta)$  converges a.e. and there is an estimate

$$\|\mathcal{K}f\|_{L^2(D)} \leq \sqrt{AB} \|f\|_{L^2(D)}.$$

Hence it suffices to prove (3-32) and (3-33). We can write

$$\begin{aligned}
\int_D |K(z, \zeta)| dV(\zeta) &= \int_D \left| \frac{\eta(z) + O''(|z - \zeta|)}{\bar{\Phi}^{n+1}(\zeta, z)} - \frac{\eta(\zeta) + O'(|z - \zeta|)}{\Phi^{n+1}(z, \zeta)} \right| dV(\zeta) \\
&\leq J_1 + J_2 + J_3 + J_4,
\end{aligned}$$

where we denote

$$\begin{aligned}
J_1 &= \int_D \frac{|\eta(z) - \eta(\zeta)|}{|\Phi(\zeta, z)|^{n+1}} dV(\zeta), & J_2 &= \int_D \eta(\zeta) \left| \frac{1}{\bar{\Phi}^{n+1}(\zeta, z)} - \frac{1}{\Phi^{n+1}(z, \zeta)} \right| dV(\zeta), \\
J_3 &= \int_D \frac{|O''(|z - \zeta|)|}{|\Phi(\zeta, z)|^{n+1}} dV(\zeta), & J_4 &= \int_D \frac{|O'(|z - \zeta|)|}{|\Phi(z, \zeta)|^{n+1}} dV(\zeta).
\end{aligned}$$



By the expression for  $\eta$  (3-17), we have  $|\eta(z) - \eta(\zeta)| \lesssim |\rho|_3 |\zeta - z|$ . We have

$$J_1 \lesssim |\rho|_3 \int_D \frac{|\zeta - z|}{|\Phi(\zeta, z)|^{n+1}} dV(\zeta) \lesssim |\rho|_3,$$

where we applied estimate (3-26) in the last inequality. By estimates (3-9), (3-24) and (3-26), we have

$$\begin{aligned} J_2 &\lesssim |\rho|_2 \int_D \frac{|\Phi^{n+1}(z, \zeta) - \overline{\Phi}^{n+1}(\zeta, z)|}{|\Phi(\zeta, z)|^{n+1} |\Phi^{n+1}(z, \zeta)|} dV(\zeta) \\ &\lesssim |\rho|_2 \int_D |\Phi(z, \zeta) - \overline{\Phi}(\zeta, z)| \left( \frac{|\Phi(z, \zeta)|^n + |\Phi(\zeta, z)|^n}{|\Phi(\zeta, z)|^{n+1} |\Phi^{n+1}(z, \zeta)|} \right) dV(\zeta) \\ &\lesssim |\rho|_3 \left( \int_D \frac{|\zeta - z|^3}{|\Phi(\zeta, z)|^{n+1} |\Phi(z, \zeta)|} dV(\zeta) + \int_D \frac{|\zeta - z|^3}{|\Phi(z, \zeta)|^{n+1} |\Phi(\zeta, z)|} dV(\zeta) \right) \\ &\lesssim |\rho|_3 \left( \int_D \frac{|\zeta - z|}{|\Phi(\zeta, z)|^{n+1}} dV(\zeta) + \int_D \frac{|\zeta - z|}{|\Phi(z, \zeta)|^{n+1}} dV(\zeta) \right) \\ &\lesssim |\rho|_3. \end{aligned}$$

For  $J_3$ , we use estimates (3-18), (3-21) and (3-26):

$$\begin{aligned} J_3 &\lesssim |\rho|_3 \int_D \frac{|\zeta - z|}{|\Phi(\zeta, z)|^{n+1}} dV(\zeta) \lesssim |\rho|_3, \\ J_4 &\lesssim |\rho|_3 \int_D \frac{|\zeta - z|}{|\Phi(z, \zeta)|^{n+1}} dV(\zeta) \lesssim |\rho|_3. \end{aligned}$$

Here we note that all the bounds are uniform in  $z \in D$ . Hence we have proved (3-33). In a similar way by using estimate (3-29), we can prove (3-32). The proof is now complete.  $\square$

By using Proposition 3.5 and the same argument in [Ligocka 1984], we obtain

**Proposition 3.6.** *Let  $D$  be a strictly pseudoconvex domain in  $\mathbb{C}^n$  with  $C^3$  boundary, and let  $\mathcal{L}, \mathcal{K}$  be the operators given by formula (3-19) (3-23), respectively. Then the following statements are true:*

- (1)  $\mathcal{L}$  is a bounded projection from  $L^2(D)$  to  $H^2(D)$ . In particular,  $\mathcal{L}$  is the identity map on  $H^2(D)$ .
- (2)  $\mathcal{P} = \mathcal{L}(I - \mathcal{K})^{-1} = (I + \mathcal{K})^{-1} \mathcal{L}^*$ .

It is important to note that unlike the Bergman projection,  $\mathcal{L}$  is not an orthogonal projection, namely,  $\mathcal{L}g - g$  is not orthogonal to the Bergman space  $H^2(D)$ .

**Lemma 3.7.** *Let  $D$  be a strictly pseudoconvex domain with  $C^3$  boundary, and let  $D_\delta := \{z \in \mathbb{C}^n : \rho(z) < 0\}$ :*

(i) *For all  $(z, \zeta) \in D_\delta \times D_\delta$  with  $|z - \zeta|$  sufficiently small,*

$$(3-34) \quad \left| \sum_{i=1}^n \frac{\partial \Phi(z, \zeta)}{\partial \bar{\zeta}_i} \cdot \frac{\partial \rho}{\partial \zeta_i} \right| > c > 0.$$

(ii) *For each  $\zeta_0 \in bD$ , there exists a neighborhood  $U(\zeta_0)$  and an index  $1 \leq j \leq n$  such that  $\left| \frac{\partial \rho}{\partial \zeta_j}(\zeta) \right| > c > 0$  for all  $\zeta \in U(\zeta_0)$ . In addition,*

$$(3-35) \quad \frac{\partial \Phi(z, \zeta)}{\partial \zeta_j} \frac{\partial \rho}{\partial \bar{\zeta}_j} - \frac{\partial \Phi(z, \zeta)}{\partial \bar{\zeta}_j} \frac{\partial \rho}{\partial \zeta_j} > c' > 0, \quad \forall (z, \zeta) \in U(\zeta_0) \times U(\zeta_0).$$

(iii) *For all  $(z, \zeta) \in D_\delta \times D_\delta$  with  $|z - \zeta|$  sufficiently small,*

$$(3-36) \quad \left| \sum_{i=1}^n \frac{\partial \overline{\Phi(\zeta, z)}}{\partial \bar{\zeta}_i} \cdot \frac{\partial \rho}{\partial \zeta_i} \right| > c > 0.$$

(iv) *For each  $\zeta_0 \in bD$ , there exists a neighborhood  $U(\zeta_0)$  and an index  $1 \leq j \leq n$  such that  $\left| \frac{\partial \rho}{\partial \zeta_j}(\zeta) \right| > c > 0$  for all  $\zeta \in U(\zeta_0)$ . In addition,*

$$(3-37) \quad \frac{\partial \overline{\Phi(\zeta, z)}}{\partial \zeta_j} \frac{\partial \rho}{\partial \bar{\zeta}_j} - \frac{\partial \overline{\Phi(\zeta, z)}}{\partial \bar{\zeta}_j} \frac{\partial \rho}{\partial \zeta_j} > c' > 0, \quad \forall (z, \zeta) \in U(\zeta_0) \times U(\zeta_0).$$

*Proof.* (i) Compute

$$(3-38) \quad \begin{aligned} \frac{\partial}{\partial \bar{\zeta}_i} [F(z, \zeta) - \rho(\zeta)] &= \frac{\partial}{\partial \bar{\zeta}_i} \left( \sum_{j=1}^n \frac{\partial \rho}{\partial \zeta_j}(\zeta) (\zeta_j - z_j) \right. \\ &\quad \left. - \frac{1}{2} \sum_{j,k=1}^n \frac{\partial^2 \rho}{\partial \zeta_j \partial \bar{\zeta}_k}(\zeta) (z_j - \zeta_j) (z_k - \zeta_k) - \rho(\zeta) \right) \\ &= -\frac{\partial \rho}{\partial \bar{\zeta}_i}(\zeta) + O(|\zeta - z|). \end{aligned}$$

Estimate (3-34) then follows for  $|z - \zeta|$  small since  $|\nabla \rho(\zeta)| > 0$ .

(ii) Since  $d\rho(\zeta_0) \neq 0$ , there exists some neighborhood  $U(\zeta_0)$  and an index  $i_0$  such that  $\left| \frac{\partial \rho}{\partial \bar{\zeta}_{i_0}}(\zeta) \right| \geq c > 0$  for all  $\zeta \in U(\zeta_0)$ . We compute

$$\begin{aligned}
 (3-39) \quad \frac{\partial}{\partial \bar{\zeta}_{i_0}} [F(z, \zeta) - \rho(\zeta)] &= \frac{\partial}{\partial \bar{\zeta}_{i_0}} \left( \sum_{j=1}^n \frac{\partial \rho}{\partial \zeta_j}(\zeta) (\zeta_j - z_j) \right. \\
 &\quad \left. - \frac{1}{2} \sum_{j,k=1}^n \frac{\partial^2 \rho}{\partial \zeta_j \partial \zeta_k}(\zeta) (z_j - \zeta_j)(z_k - \zeta_k) - \rho(\zeta) \right) \\
 &= \frac{\partial \rho}{\partial \bar{\zeta}_{i_0}}(\zeta) - \frac{\partial \rho}{\partial \bar{\zeta}_{i_0}}(\zeta) + O(|\zeta - z|) \\
 &= O(|\zeta - z|).
 \end{aligned}$$

It follows from (3-38) and (3-39) that

$$\frac{\partial [F(z, \zeta) - \rho(\zeta)]}{\partial \bar{\zeta}_{i_0}} \frac{\partial \rho}{\partial \bar{\zeta}_{i_0}} - \frac{\partial [F(z, \zeta) - \rho(\zeta)]}{\partial \bar{\zeta}_{i_0}} \frac{\partial \rho}{\partial \zeta_{i_0}} = \left| \frac{\partial \rho}{\partial \bar{\zeta}_{i_0}}(\zeta) \right|^2 + O(|\zeta - z|).$$

Estimate (3-35) then follows if  $U(\zeta_0)$  is chosen sufficiently small.

(iii) The proof follows similarly by the fact

$$\begin{aligned}
 (3-40) \quad \frac{\partial}{\partial \bar{\zeta}_i} [\overline{F(\zeta, z)} - \rho(z)] &= \frac{\partial}{\partial \bar{\zeta}_i} \left( \sum_{j=1}^n \frac{\partial \rho}{\partial \bar{z}_j}(z) \overline{(z_j - \zeta_j)} \right. \\
 &\quad \left. - \sum_{j,k=1}^n \frac{\partial^2 \rho}{\partial \bar{z}_j \partial \bar{z}_k}(z) \overline{(\zeta_j - z_j)(\zeta_k - z_k)} - \rho(z) \right) \\
 &= -\frac{\partial \rho}{\partial \bar{z}_i}(z) + O(|\zeta - z|) \\
 &= -\frac{\partial \rho}{\partial \bar{\zeta}_i}(\zeta) + O(|\zeta - z|),
 \end{aligned}$$

where in the last equality we used that  $|D\rho(z) - D\rho(\zeta)| \lesssim |\rho|_2 |\zeta - z|$ .

(iv) Since  $d\rho(\zeta_0) \neq 0$ , there exists some neighborhood  $U(\zeta_0)$  and an index  $i_0$  such that  $\left| \frac{\partial \rho}{\partial \bar{\zeta}_{i_0}}(\zeta) \right| \geq c > 0$  for all  $\zeta \in U(\zeta_0)$ . Compute

$$\begin{aligned}
 (3-41) \quad \frac{\partial}{\partial \bar{\zeta}_{i_0}} [\overline{F(\zeta, z)} - \rho(z)] &= \frac{\partial}{\partial \bar{\zeta}_{i_0}} \left( \sum_{j=1}^n \frac{\partial \rho}{\partial \bar{z}_j}(z) \overline{(z_j - \zeta_j)} \right. \\
 &\quad \left. - \frac{1}{2} \sum_{j,k=1}^n \frac{\partial^2 \rho}{\partial z_j \partial \bar{z}_k}(z) \overline{(\zeta_j - z_j)(\zeta_k - z_k)} - \rho(z) \right) \\
 &= 0.
 \end{aligned}$$

It follows from (3-40) and (3-41) that

$$\frac{\partial[\overline{F(\zeta, z)} - \rho(z)]}{\partial \zeta_{i_0}} \frac{\partial \rho}{\partial \bar{\zeta}_{i_0}} - \frac{\partial[\overline{F(\zeta, z)} - \rho(z)]}{\partial \bar{\zeta}_{i_0}} \frac{\partial \rho}{\partial \zeta_{i_0}} = \left| \frac{\partial \rho}{\partial \zeta_{i_0}}(\zeta) \right|^2 + O(|\zeta - z|).$$

Hence estimate (3-37) holds by choosing  $U(\xi_0)$  sufficiently small.  $\square$

**Lemma 3.8.** *Let  $D$  be a bounded strictly pseudoconvex domain with a  $C^3$  defining function  $\rho$ , and let  $F(z, \zeta)$  be given by (3-1):*

(i) *For each  $1 \leq i \leq n$ , the following holds for  $(z, \zeta) \in D \times D$ ,*

$$\frac{\partial[F(z, \zeta) - \rho(\zeta)]}{\partial z_i} = -\frac{\partial \rho}{\partial \zeta_i}(\zeta) + O(|\zeta - z|), \quad \frac{\partial[F(z, \zeta) - \rho(\zeta)]}{\partial \bar{z}_i} = O(|\zeta - z|),$$

where  $|O(|\zeta - z|)| \lesssim |\rho|_2 |\zeta - z|$ .

(ii) *For each  $1 \leq i \leq n$ , the following holds for  $(z, \zeta) \in D_\delta \times D_\delta$ ,*

$$\frac{\partial[\overline{F(\zeta, z)} - \rho(z)]}{\partial z_i} = -\frac{\partial \rho}{\partial z_i}(z) + O(|\zeta - z|), \quad \frac{\partial[\overline{F(\zeta, z)} - \rho(z)]}{\partial \bar{z}_i} = O(|\zeta - z|),$$

where  $|O(|\zeta - z|)| \lesssim |\rho|_3 |\zeta - z|$ .

*Proof.* (i) Using definition of  $F$ , we have

$$\begin{aligned} \frac{\partial[F(z, \zeta) - \rho(\zeta)]}{\partial z_i} &= \frac{\partial}{\partial z_i} \left( \sum_{j=1}^n \frac{\partial \rho}{\partial \zeta_j}(\zeta) (\zeta_j - z_j) \right. \\ &\quad \left. - \frac{1}{2} \sum_{j,k=1}^n \frac{\partial^2 \rho}{\partial \zeta_j \partial \zeta_k}(\zeta) (z_j - \zeta_j)(z_k - \zeta_k) - \rho(\zeta) \right) \\ &= -\frac{\partial \rho}{\partial \zeta_i}(\zeta) + O(|\zeta - z|), \end{aligned}$$

$|O(|\zeta - z|)| \lesssim |\rho|_2 |\zeta - z|$ , and  $\partial[F(z, \zeta) - \rho(\zeta)]/\partial \bar{z}_i = O(|\zeta - z|)$ .

$$\begin{aligned} \text{(ii)} \quad \frac{\partial[\overline{F(\zeta, z)} - \rho(z)]}{\partial z_i} &= \frac{\partial}{\partial z_i} \left( \sum_{j=1}^n \frac{\partial \rho}{\partial \bar{z}_j}(z) \overline{(z_j - \zeta_j)} \right. \\ &\quad \left. - \frac{1}{2} \sum_{j,k=1}^n \frac{\partial^2 \rho}{\partial z_j \partial z_k}(z) \overline{(\zeta_j - z_j)(\zeta_k - z_k)} - \rho(z) \right) \\ &= -\frac{\partial \rho}{\partial z_i}(z) + O(|\zeta - z|), \quad |O(|\zeta - z|)| \lesssim |\rho|_3 |\zeta - z|, \end{aligned}$$

and

$$\frac{\partial[\overline{F(\zeta, z)} - \rho(z)]}{\partial \bar{z}_i} = \frac{\partial \rho}{\partial \bar{z}_i} - \frac{\partial \rho}{\partial \bar{z}_i} + O(|\zeta - z|) = O(|\zeta - z|). \quad \square$$

We use the notation:

$$(3-42) \quad Q'(z, \zeta) := \sum_{i=1}^n \frac{\partial \Phi(z, \zeta)}{\partial \bar{\zeta}_i} \frac{\partial \rho}{\partial \zeta_i}, \quad Q''(\zeta, z) := \sum_{i=1}^n \frac{\partial \overline{\Phi(\zeta, z)}}{\partial \bar{\zeta}_i} \cdot \frac{\partial \rho}{\partial \zeta_i},$$

and we write

$$[d\bar{\zeta}]_i = d\bar{\zeta}_1 \wedge \cdots \wedge \widehat{(d\bar{\zeta}_i)} \wedge \cdots \wedge d\bar{\zeta}_n; \quad [d\zeta]_i = d\zeta_1 \wedge \cdots \wedge \widehat{(d\zeta_i)} \wedge \cdots \wedge d\zeta_n.$$

**Lemma 3.9.** *For all  $(z, \zeta) \in D_\delta \times D_\delta$  with  $|z - \zeta|$  sufficiently small, the following estimates hold:*

- (i)  $|D_z \Phi(z, \zeta) - D_z \overline{\Phi(\zeta, z)}| \lesssim |\rho|_3 |z - \zeta|.$
- (ii)  $|D_\zeta \Phi(z, \zeta) - D_\zeta \overline{\Phi(\zeta, z)}| \lesssim |\rho|_3 |z - \zeta|.$
- (iii)  $|Q'(z, \zeta) - Q''(\zeta, z)| \lesssim |\rho|_3 |z - \zeta|.$

*Proof.* This follows immediately from the proof of [Lemma 3.7](#) and [Lemma 3.8](#).  $\square$

We now prove the key integration by parts lemma. This technique was originated by Elgueta [1980] and has been developed and used by Ahern and Schneider [1979], Ligočka [1984], Lieb and Range [1980], and Gong [2019], among others. For our proof we shall mainly follow [Ahern and Schneider 1979]. We mention that integration by parts is not needed for our results with  $C^{3+\alpha}$  boundary, and that in the subsequent proof the following lemma will only be applied to domains with  $C^{k+3+\alpha}$  boundary,  $k \geq 1$ .

**Lemma 3.10.** *Let  $D$  be a bounded strictly pseudoconvex domain in  $\mathbb{C}^n$  with  $C^4$  boundary. Suppose  $u \in C^1(\bar{D})$  and the support of  $u$  is contained in some small neighborhood of  $z$ . Then the following integration by parts formulae hold:*

(i) Here  $P'$  is a first order differential operator in  $\zeta$  variable (see (3-51)):

$$(3-43) \quad \int_D \frac{u(\zeta) dV(\zeta)}{\Phi^{m+1}(z, \zeta)} \\ = c'_1 \int_{bD} \frac{P'(u)(\zeta) d\sigma(\zeta)}{\Phi^{m-1}(z, \zeta)} + c'_2 \int_D \sum_{i=1}^n \frac{\partial}{\partial \bar{\zeta}_i} \left( \frac{u(\zeta) \frac{\partial \rho}{\partial \zeta_i}(\zeta)}{Q'(z, \zeta)} \right) \frac{dV(\zeta)}{\Phi^m(z, \zeta)}.$$

(ii) Here  $P''$  is a first order differential operator in  $\zeta$  (see (3-55)):

$$(3-44) \quad \int_D \frac{u(\zeta) dV(\zeta)}{\bar{\Phi}^{m+1}(\zeta, z)} \\ = c''_1 \int_{bD} \frac{P''(u)(\zeta) d\sigma(\zeta)}{\bar{\Phi}^{m-1}(\zeta, z)} + c''_2 \int_D \sum_{i=1}^n \frac{\partial}{\partial \bar{\zeta}_i} \left( \frac{u(\zeta) \frac{\partial \rho}{\partial \zeta_i}(\zeta)}{Q''(\zeta, z)} \right) \frac{dV(\zeta)}{\bar{\Phi}^m(\zeta, z)}.$$

(iii) Here  $P'$ ,  $P''$  are first order differential operators in  $\zeta$ . The coefficients of  $P'$  (resp.  $P''$ ) involve derivatives of  $\rho$  up to order 3 (resp. order 2):

$$(3-45) \quad \begin{aligned} \int_{bD} \frac{u(\zeta)d\sigma(\zeta)}{\Phi^m(z, \zeta)} &= \int_{bD} \frac{P'(u)(\zeta) d\sigma(\zeta)}{\Phi^{m-1}(z, \zeta)}, \\ \int_{bD} \frac{u(\zeta) d\sigma(\zeta)}{\Phi^m(\zeta, z)} &= \int_{bD} \frac{P''(u)(\zeta) d\sigma(\zeta)}{\Phi^{m-1}(\zeta, z)}. \end{aligned}$$

*Proof.* In view of (3-5) and (3-8), for each fixed  $z \in D$  we have  $\Phi(z, \cdot) \in C^1(\bar{D})$ . By (3-42), and the assumption that  $\rho \in C^3$ , we see that  $Q'$ ,  $Q'' \in C^1(\bar{D})$ . Hence by Stokes' theorem,

$$(3-46) \quad \begin{aligned} \int_D \frac{u(\zeta)}{\Phi^{m+1}(z, \zeta)} dV(\zeta) &= -\frac{1}{m} \int_{bD} \frac{u(\zeta)}{Q'(z, \zeta)\Phi^m(z, \zeta)} \sum_{k=1}^n (-1)^{k-1} \frac{\partial \rho}{\partial \zeta_k} [d\bar{\zeta}]_k \wedge d\zeta \\ &\quad + \frac{1}{m} \int_D \sum_{k=1}^n \frac{\partial}{\partial \bar{\zeta}_k} \left( \frac{u(\zeta) \frac{\partial \rho}{\partial \zeta_k}(\zeta)}{Q'(z, \zeta)} \right) \frac{1}{\Phi^m(z, \zeta)} dV(\zeta). \end{aligned}$$

To finish the proof we need to apply Stokes' theorem again to the boundary integral. We have on  $bD$ ,

$$(3-47) \quad d\rho(\zeta) = \sum_{l=1}^n \left( \frac{\partial \rho}{\partial \zeta_l} d\zeta_l + \frac{\partial \rho}{\partial \bar{\zeta}_l} d\bar{\zeta}_l \right) \equiv 0.$$

Let  $\{\chi_\nu\}_{\nu=1}^M$  be a partition of unity of  $bD$  subordinate to the cover  $\{U_\nu\}_{\nu=1}^M$ . We can assume that on  $U_\nu$ , there exists an index  $i = i(\nu)$  such that  $\frac{\partial \rho}{\partial \zeta_{i(\nu)}}(\zeta) \neq 0$ . By (3-47), we have for  $\zeta \in U_\nu \cap bD$ :

$$(3-48) \quad \begin{aligned} d_\zeta(\Phi^{-(m-1)}[d\zeta]_i \wedge [d\bar{\zeta}]_i) &= -(m-1)\Phi^{-m} \left( \sum_{l=1}^n \frac{\partial \Phi(z, \zeta)}{\partial \zeta_l} d\zeta_l + \frac{\partial \Phi(z, \zeta)}{\partial \bar{\zeta}_l} d\bar{\zeta}_l \right) \wedge [d\zeta]_i \wedge [d\bar{\zeta}]_i \\ &= -(m-1)\Phi^{-m} \left[ \frac{\partial \Phi(z, \zeta)}{\partial \zeta_i} - \frac{\partial \rho}{\partial \zeta_i} \left( \frac{\partial \rho}{\partial \bar{\zeta}_i} \right)^{-1} \frac{\partial \Phi(z, \zeta)}{\partial \bar{\zeta}_i} \right] d\zeta_i \wedge [d\zeta]_i \wedge [d\bar{\zeta}]_i \\ &= -(m-1)\Phi^{-m} (-1)^{i-1} a_i(z, \zeta) d\zeta \wedge [d\bar{\zeta}]_i, \end{aligned}$$

where  $i = i(\nu)$  and we set

$$(3-49) \quad a_i(z, \zeta) := \frac{\partial \Phi(z, \zeta)}{\partial \zeta_i} - \frac{\partial \rho}{\partial \zeta_i} \left( \frac{\partial \rho}{\partial \bar{\zeta}_i} \right)^{-1} \frac{\partial \Phi(z, \zeta)}{\partial \bar{\zeta}_i}, \quad \zeta \in U_\nu \cap bD.$$

By assumption,  $u$  is supported in a small neighborhood of  $z$ . Hence if for some  $v$ ,  $\text{supp } u \cap U_v$  is nonempty, then  $z$  must be sufficiently close to  $U_v$ . Hence in view of estimate (3-35) and by shrinking  $U_v$  if necessary, we can assume that  $a_i(z, \zeta) \geq c > 0$  for  $\zeta \in \text{supp } u \cap U_v$ . Accordingly,

$$\Phi^{-m} d\zeta \wedge [d\bar{\zeta}]_i = c_m \frac{(-1)^{i-1}}{a_i(z, \zeta)} d_\zeta (\Phi^{-(m-1)} [d\zeta]_i \wedge [d\bar{\zeta}]_i), \quad i = i(v), \zeta \in U_v \cap bD.$$

Now by (3-47) we can write

$$(3-50) \quad \sum_{k=1}^n (-1)^{k-1} \frac{\partial \rho}{\partial \zeta_k} d\zeta \wedge [d\bar{\zeta}]_k = \varphi_v(\zeta) d\zeta \wedge [d\bar{\zeta}]_{i(v)}, \quad \zeta \in U_v \cap bD,$$

where  $\varphi_v$  is a linear combination of products of  $\frac{\partial \rho}{\partial \zeta_s}$  and  $\frac{\partial \rho}{\partial \bar{\zeta}_t}$ . Hence for the boundary integral in (3-46) we have

$$\begin{aligned} \int_{bD} \frac{u(\zeta) \chi_v(\zeta)}{Q'(z, \zeta) \Phi^m(z, \zeta)} \sum_{k=1}^n (-1)^{k-1} \frac{\partial \rho}{\partial \zeta_k} d\zeta \wedge [d\bar{\zeta}]_k \\ = \int_{bD} \frac{u(\zeta) \chi_v(\zeta) \varphi_v(\zeta)}{Q'(z, \zeta) \Phi^m(z, \zeta)} d\zeta \wedge [d\bar{\zeta}]_{i(v)} \\ = \int_{bD} \frac{u(\zeta) \chi_v(\zeta) \varphi_v(\zeta)}{(Q' a_{i(v)})(z, \zeta)} d_\zeta (\Phi^{-(m-1)} [d\zeta]_{i(v)} \wedge [d\bar{\zeta}]_{i(v)}), \end{aligned}$$

where the constant is absorbed into  $\varphi_v$ . By Stokes' theorem, the integral is equal to

$$\int_{bD} d_\zeta \left( \frac{u(\zeta) (\chi_v \varphi_v)(\zeta)}{(Q' a_{i(v)})(z, \zeta)} \right) \Phi^{-(m-1)} [d\zeta]_{i(v)} \wedge [d\bar{\zeta}]_{i(v)}.$$

Let  $\psi_v$  be the function such that  $[d\zeta]_{i(v)} \wedge [d\bar{\zeta}]_{i(v)} = \psi_v(\zeta) d\sigma(\zeta)$ . Summing the above expression over  $v$ , the boundary integral in (3-46) can be written as

$$(3-51) \quad \int_{bD} P'(u)(\zeta) \Phi^{-(m-1)} d\sigma(\zeta), \quad P'(u)(\zeta) := \sum_{v=1}^M d_\zeta \left( \frac{u(\zeta) (\chi_v \varphi_v)(\zeta)}{(Q' a_{i(v)})(z, \zeta)} \right) \psi_v(\zeta).$$

Hence we obtain formula (3-43). This completes the proof of (i).

The proof of (ii) goes similar. By Stokes' theorem we have

$$(3-52) \quad \begin{aligned} \int_D \frac{u(\zeta)}{\bar{\Phi}^{m+1}(\zeta, z)} dV(\zeta) \\ = -\frac{1}{m} \int_{bD} \frac{u(\zeta)}{Q''(\zeta, z) \bar{\Phi}^m(\zeta, z)} \sum_{k=1}^n (-1)^{k-1} \frac{\partial \rho}{\partial \zeta_k} [d\bar{\zeta}]_k \wedge d\zeta \\ + \frac{1}{m} \int_D \sum_{k=1}^n \frac{\partial}{\partial \bar{\zeta}_k} \left( \frac{u(\zeta) \frac{\partial \rho}{\partial \zeta_k}(\zeta)}{Q''(\zeta, z)} \right) \frac{1}{\bar{\Phi}^m(\zeta, z)} dV(\zeta). \end{aligned}$$

Let  $\chi_\nu$ ,  $U_\nu$  and  $i(\nu)$  be the same as in the proof of (i). By (3-47), we have for  $\zeta \in U_\nu \cap bD$ :

$$\begin{aligned}
 (3-53) \quad & d_\zeta \bar{\Phi}^{-(m-1)}(\zeta, z) [d\zeta]_i \wedge [d\bar{\zeta}]_i \\
 &= -m \bar{\Phi}^{-m}(\zeta, z) \left( \frac{\partial \bar{\Phi}(\zeta, z)}{\partial \zeta_i} d\zeta_i + \frac{\partial \bar{\Phi}(\zeta, z)}{\partial \bar{\zeta}_i} d\bar{\zeta}_i \right) \wedge [d\zeta]_i \wedge [d\bar{\zeta}]_i \\
 &= -m \bar{\Phi}^{-m}(\zeta, z) \left[ \frac{\partial \bar{\Phi}(\zeta, z)}{\partial \zeta_i} - \frac{\partial \rho}{\partial \zeta_i} \left( \frac{\partial \rho}{\partial \bar{\zeta}_i} \right)^{-1} \frac{\partial \bar{\Phi}(\zeta, z)}{\partial \bar{\zeta}_i} \right] d\zeta_i \wedge [d\zeta]_i \wedge [d\bar{\zeta}]_i \\
 &= -m \bar{\Phi}^{-m}(\zeta, z) (-1)^{i-1} b_i(\zeta, z) d\zeta \wedge [d\bar{\zeta}]_i,
 \end{aligned}$$

where  $i = i(\nu)$  and we set

$$(3-54) \quad b_i(\zeta, z) := \frac{\partial \bar{\Phi}(\zeta, z)}{\partial \zeta_i} - \frac{\partial \rho}{\partial \zeta_i} \left( \frac{\partial \rho}{\partial \bar{\zeta}_i} \right)^{-1} \frac{\partial \bar{\Phi}(\zeta, z)}{\partial \bar{\zeta}_i}, \quad \zeta \in U_\nu \cap bD.$$

Using estimate (3-37), we may assume that  $b_i \geq c > 0$  for  $\zeta \in \text{supp } u \cap U_\nu$ . It follows that

$$\bar{\Phi}^{-m}(\zeta, z) d\zeta \wedge [d\bar{\zeta}]_i = c_m \frac{(-1)^{i-1}}{b_i(\zeta, z)} d_\zeta (\bar{\Phi}^{-(m-1)}(\zeta, z) [d\zeta]_i \wedge [d\bar{\zeta}]_i),$$

where  $i = i(\nu)$ ,  $\zeta \in U_\nu \cap bD$ . By (3-50), the boundary integral in (3-52) can be written as

$$\begin{aligned}
 & \int_{bD} \frac{u(\zeta) \chi_\nu(\zeta)}{Q''(z, \zeta) \bar{\Phi}^m(\zeta, z)} \sum_{k=1}^n (-1)^{k-1} \frac{\partial \rho}{\partial \zeta_k} [d\bar{\zeta}]_k \wedge d\zeta \\
 &= \int_{bD} \frac{u(\zeta) \chi_\nu(\zeta) \varphi_\nu(\zeta)}{Q''(z, \zeta) \bar{\Phi}^m(\zeta, z)} d\zeta \wedge [d\bar{\zeta}]_{i(\nu)} \\
 &= \int_{bD} \frac{u(\zeta) \chi_\nu(\zeta) \varphi_\nu(\zeta)}{(Q'' b_{i(\nu)})(z, \zeta)} d_\zeta (\bar{\Phi}^{-(m-1)}(\zeta, z) [d\zeta]_{i(\nu)} \wedge [d\bar{\zeta}]_{i(\nu)}),
 \end{aligned}$$

where the constant is absorbed into  $\varphi_\nu$ . By Stokes' theorem, the integral is equal to

$$\int_{bD} d_\zeta \left( \frac{u(\zeta) (\chi_\nu \varphi_\nu)(\zeta)}{(Q'' b_{i(\nu)})(z, \zeta)} \right) \bar{\Phi}^{-(m-1)}(\zeta, z) [d\zeta]_{i(\nu)} \wedge [d\bar{\zeta}]_{i(\nu)}.$$

Let  $\psi_\nu$  be the function such that  $[d\zeta]_{i(\nu)} \wedge [d\bar{\zeta}]_{i(\nu)} = \psi_\nu(\zeta) d\sigma(\zeta)$ . Summing the above expression over  $\nu$ , the boundary integral in (3-52) can be written as

$$(3-55) \quad \int_{bD} P''(u)(\zeta) \bar{\Phi}^{-(m-1)}(\zeta, z) d\sigma(\zeta), \quad P''(u)(\zeta) := \sum_{\nu=1}^M d_\zeta \left( \frac{u(\zeta) (\chi_\nu \varphi_\nu)(\zeta)}{(Q'' b_{i(\nu)})(z, \zeta)} \right) \psi_\nu(\zeta).$$

Hence we obtain formula (3-44).

Finally, the proof of (iii) is clear from the proofs of (i) and (ii).  $\square$



In this section we prove [Proposition 1.2](#) and then use it to prove [Theorem 1.1](#) and [Theorem 1.3](#). First we fix some notations. We will write  $|f|_r = |f|_{C^r(\bar{D})}$ , where  $|\cdot|_{C^r(\bar{D})}$  denotes the Hölder  $r$ -norm on  $D$ . We also write  $\delta(z) := \text{dist}(z, bD)$ .

#### 4. Proof of Proposition 1.2 and Theorem 1.1

In this section we prove [Theorem 1.1](#). We begin with [Proposition 1.2](#).

*Proof of Proposition 1.2.* We shall assume that  $\rho$  is a regularized defining function satisfying the properties in [Proposition 2.2](#). In particular, we have  $\rho \in C^\infty(\mathbb{C}^n) \cap C^{k+3+\alpha}(\bar{D})$  and

$$(4-1) \quad |D^j \rho(z)| \lesssim C_j |\rho|_{k+2+\alpha} (1 + \delta(z)^{k+3+\alpha-j}), \quad j = 0, 1, 2, \dots$$

We recall the notation

$$\Phi(z, \zeta) := G(z, \zeta) - \rho(\zeta), \quad \overline{\Phi(\zeta, z)} := \overline{G(\zeta, z)} - \rho(z).$$

In view of [\(3-22\)](#), we can write

$$\mathcal{K}f(z) = \mathcal{K}_0 f(z) + \mathcal{K}_1 f(z) := \int_D K_0(z, \zeta) f(\zeta) dV(\zeta) + \int_D K_1(z, \zeta) f(\zeta) dV(\zeta),$$

where  $K_0(z, \zeta) := \overline{L_0(\zeta, z)} - L_0(z, \zeta)$  and  $K_1(z, \zeta) = \overline{L_1(\zeta, z)} - L_1(z, \zeta)$ . We first estimate  $\mathcal{K}_0 f$ . In view of [\(3-22\)](#), we have

$$\mathcal{K}_0 f(z) = \int_D f(\zeta) (\overline{L_0(\zeta, z)} - L_0(z, \zeta)) dV(\zeta).$$

where  $L_0(z, \zeta) dV(\zeta) = S_z(\bar{\partial}_z \bar{\partial}_\zeta N)(z, \zeta)$ . As observed earlier, since  $bD \in C^{k+3+\alpha}$ , the coefficients of  $\bar{\partial}_z \bar{\partial}_\zeta N(z, \zeta)$  belong to the class  $C^\infty \times C^{k+\alpha}(D_\delta(z) \times D_\delta(\zeta))$ . By [Proposition 2.1](#) and the fact that  $S_z$  is a linear operator, we see that  $L_0(z, \zeta) \in C^\infty \times C^{k+\alpha}(D_\delta(z) \times D_\delta(\zeta))$ , which also implies  $L_0(\zeta, z) \in C^\infty \times C^{k+\alpha}(D_\delta(\zeta) \times D_\delta(z))$ .

Accordingly, we have

$$(4-2) \quad \int_D f(\zeta) L_0(z, \zeta) dV(\zeta) \in C^\infty(\bar{D}), \quad \int_D f(\zeta) \overline{L_0(\zeta, z)} dV(\zeta) \in C^{k+\alpha}(\bar{D}).$$

Here the first statement is clear. We now prove the second statement. By estimate [\(4-1\)](#) and the expression for  $L_0(\zeta, z)$ , it follows that

$$\left| \int_D f(\zeta) D_z^{k+1} \overline{L_0(\zeta, z)} dV(\zeta) \right| \lesssim |f|_0 (1 + \delta(z)^{-1+\alpha}).$$

Hence by [Lemma 2.3](#), the second integral in [\(4-2\)](#) belongs to  $C^{k+\alpha}(\bar{D})$ . Thus we have shown  $\mathcal{K}_0 f \in C^{k+\alpha}(\bar{D})$ .

Next we estimate  $\mathcal{K}_1 f$ . First we prove for the case  $k = 0$ , i.e.,  $\rho \in C^{3+\alpha}$ . In view of (3-17), we have

$$\begin{aligned} \mathcal{K}_1 f(z) &= \int_D f(\zeta) (\overline{L_1(\zeta, z)} - L_1(z, \zeta)) dV(\zeta) \\ &= \int_D f(\zeta) \left[ \frac{\eta(z) + O''(|z - \zeta|)}{\overline{\Phi}^{n+1}(\zeta, z)} - \frac{\eta(\zeta) + O'(|z - \zeta|)}{\Phi^{n+1}(z, \zeta)} \right] dV(\zeta). \end{aligned}$$

Let  $\chi_0$  be a  $C^\infty$  cut-off function supported in the set  $E_0 := \{(z, \zeta) \in D \times D : |z - \zeta| < \delta_0\}$ , and  $\chi_0 \equiv 1$  in  $\{(z, \zeta) \in D \times D : |z - \zeta| < \delta_0/2\}$ , for some  $\delta_0 > 0$ . From the definition of  $G(z, \zeta)$  (see (3-5)), we can choose  $\delta_0$  to be sufficiently small such that on the set  $E_0$ , we have  $\Phi(z, \zeta) = F(z, \zeta) - \rho(\zeta)$ . Write

$$\mathcal{K}_1 f(z) = \mathcal{K}'_1 f(z) + \mathcal{K}''_1 f(z),$$

where

$$\begin{aligned} \mathcal{K}'_1 f(z) &:= \int_D f(\zeta) (\chi_0 K_1)(z, \zeta) dV(\zeta), \\ \mathcal{K}''_1 f(z) &= \int_D f(\zeta) [(1 - \chi_0) K_1](z, \zeta) dV(\zeta), \end{aligned}$$

with  $K_1(z, \zeta) = \overline{L_1(\zeta, z)} - L_1(z, \zeta)$ . The function  $(1 - \chi_0)K_1$  is supported in  $E_1 := \{(z, \zeta) \in D \times D : |z - \zeta| \geq \varepsilon_0/2\}$ . By estimate (3-7) and the assumption  $\rho \in C^{k+3+\alpha}$ , we see that  $(1 - \chi_0)L_1(z, \zeta) \in C^\infty \times C^{k+\alpha}(\overline{D}(z) \times \overline{D}(\zeta))$  and  $(1 - \chi_0)L_1(\zeta, z) \in C^{k+\alpha} \times C^\infty(\overline{D}(z) \times \overline{D}(\zeta))$ . By the same argument used to prove (4-2), we can show that  $\mathcal{K}''_1 f \in C^{k+\alpha}(\overline{D})$ .

It remains to estimate  $\mathcal{K}'_1 f$ . We will divide the proof into two steps. In the first part, we show that if  $bD \in C^{3+\alpha}$ , then  $\mathcal{K}'_1 f \in C^{\min\{\alpha, 1/2\}}$ . In the second part, we use integration by parts to show that if  $bD \in C^{k+3+\alpha}$ , for  $k \geq 1$ , then  $\mathcal{K}'_1 f \in C^{k+\min\{\alpha, 1/2\}}$ .

Case 1:  $bD \in C^{3+\alpha}$  Assume now that  $bD \in C^{3+\alpha}$ . In what follows we will write  $D_0 = D_0(z) = \{\zeta \in D : |\zeta - z| \leq \delta_0\}$ , and without loss of generality we can assume  $f$  is supported in  $D_0$ . Taking  $z_j$  derivative we get

$$\begin{aligned} \frac{\partial \mathcal{K}'_1 f}{\partial z_j}(z) &= \int_D f(\zeta) \left( \frac{\frac{\partial}{\partial z_j} [\eta(z) + O''(|z - \zeta|)]}{\overline{\Phi}^{n+1}(\zeta, z)} - \frac{\frac{\partial}{\partial z_j} [\eta(\zeta) + O'(|z - \zeta|)]}{\Phi^{n+1}(z, \zeta)} \right) dV(\zeta) \\ &\quad - (n+1) \int_D f(\zeta) \left( \frac{[\frac{\partial}{\partial z_j} \overline{\Phi}(\zeta, z)](\eta(z) + O''(|z - \zeta|))}{\overline{\Phi}^{n+2}(\zeta, z)} \right. \\ &\quad \left. - \frac{[\frac{\partial}{\partial z_j} \Phi(z, \zeta)](\eta(\zeta) + O'(|z - \zeta|))}{\Phi^{n+2}(z, \zeta)} \right) dV(\zeta) \\ &:= I_1(z) + I_2(z), \end{aligned}$$

where we denote the first and second integral by  $I_1$  and  $I_2$ , respectively. We first estimate  $I_1$ . By (3-18), we have

$$\left| \frac{\partial}{\partial z_j} [\eta(\zeta) + O'(|z - \zeta|)] \right| \lesssim |\rho|_3.$$

Hence by (3-30),

$$(4-3) \quad \int_D \frac{|pa_{z_j}[\eta(\zeta) + O'(|z - \zeta|)]|}{|\Phi^{n+1}(z, \zeta)|} |f(\zeta)| dV(\zeta) \lesssim |f|_0 |\rho|_3 \int_D \frac{dV(\zeta)}{|\Phi(z, \zeta)|^{n+1}} \\ \lesssim |f|_0 |\rho|_3 (1 + \log \delta(z)).$$

On the other hand, using estimate (3-21) we have

$$\left| \frac{\partial}{\partial z_j} [\eta(z) + O''(|z - \zeta|)] \right| \lesssim |D_z^3 \rho(z)| + |D_z^4 \rho(z)| |\zeta - z| \\ \lesssim |\rho|_{3+\alpha} (1 + \delta(z)^{-1+\alpha} |\zeta - z|),$$

where in the last inequality we applied (4-1) with  $k = 0$  and  $j = 4$ .

Thus applying (3-26) and (3-30) we obtain

$$(4-4) \quad \int_D \frac{|\partial_{z_j} [\eta(z) + O''(|z - \zeta|)]|}{|\bar{\Phi}^{n+1}(\zeta, z)|} |f(\zeta)| dV(\zeta) \\ \lesssim |\rho|_{3+\alpha} |f|_0 \left( \int_D \frac{dV(\zeta)}{|\Phi(\zeta, z)|^{n+1}} + \delta(z)^{-1+\alpha} \int_D \frac{|\zeta - z|}{|\Phi(\zeta, z)|^{n+1}} dV(\zeta) \right) \\ \lesssim |\rho|_{3+\alpha} |f|_0 (\log \delta(z) + \delta(z)^{-1+\alpha}) \lesssim |\rho|_{3+\alpha} |f|_0 \delta(z)^{-1+\alpha}.$$

Putting together estimates (4-3) and (4-4), we get

$$(4-5) \quad |I_1(z)| \lesssim |\rho|_{3+\alpha} |f|_0 \delta(z)^{-1+\alpha}, \quad 0 < \alpha < 1.$$

For the integral  $I_2$ , we can write it as  $I_2(z) = -(n+1) \sum_{i=1}^3 J_i(z)$ , where

$$J_1(z) = \int_D f(\zeta) \left( \frac{\partial \bar{\Phi}(\zeta, z)}{\partial z_j} - \frac{\partial \Phi(z, \zeta)}{\partial z_j} \right) \frac{[\eta(z) + O''(|z - \zeta|)]}{\bar{\Phi}^{n+2}(\zeta, z)} dV(\zeta); \\ J_2(z) = \int_D f(\zeta) [\eta(z) - \eta(\zeta) + O''(|z - \zeta|) - O'(|z - \zeta|)] \frac{\partial_{z_j} \Phi(z, \zeta)}{\bar{\Phi}^{n+2}(\zeta, z)} dV(\zeta); \\ J_3(z) = \int_D f(\zeta) \left[ \frac{\partial \Phi(z, \zeta)}{\partial z_j} \right] [\eta(\zeta) + O'(|z - \zeta|)] \\ \times \left( \frac{1}{\bar{\Phi}^{n+2}(\zeta, z)} - \frac{1}{\Phi^{n+2}(z, \zeta)} \right) dV(\zeta).$$

To estimate  $J_1$ , we note that by [Lemma 3.9](#), for any  $\zeta \in \text{supp } f \subset D_0(z) = \{|\zeta - z| < \delta_0\}$ ,

$$\left| \frac{\partial \overline{\Phi(\zeta, z)}}{\partial z_j} - \frac{\partial \Phi(z, \zeta)}{\partial z_j} \right| \lesssim |\rho|_3 |\zeta - z|.$$

Together with estimates [\(3-21\)](#) and [\(3-9\)](#) we get

$$\begin{aligned} (4-6) \quad |J_1(z)| &\lesssim |f|_0 |\rho|_3 \int_D \frac{|\zeta - z|}{|\overline{\Phi(\zeta, z)}|^{n+2}} dV(\zeta) \\ &\lesssim |f|_0 |\rho|_3 \int_D \frac{dV(\zeta)}{|\zeta - z| |\Phi(\zeta, z)|^{n+1}} \\ &\lesssim |f|_0 |\rho|_3 \delta(z)^{-1/2}, \end{aligned}$$

where in the last inequality we applied estimate [\(3-25\)](#) with  $\alpha = 1$ . For  $J_2$ , we note that  $|\eta(z) - \eta(\zeta)| \lesssim |\rho|_3 |z - \zeta|$ . By [Lemma 3.8](#) (i), we have

$$(4-7) \quad \left| \frac{\partial \Phi(z, \zeta)}{\partial z_j} \right| \lesssim |\rho|_1 + |\rho|_2 |\zeta - z| \lesssim |\rho|_2.$$

Applying estimates [\(3-9\)](#), [\(3-18\)](#), [\(3-21\)](#), and [Lemma 3.2](#), we get

$$\begin{aligned} (4-8) \quad |J_2(z)| &\lesssim |f|_0 |\rho|_3 \int_D \frac{|\zeta - z|}{|\Phi(\zeta, z)|^{n+2}} dV(\zeta) \\ &\lesssim |f|_0 |\rho|_3 \int_D \frac{dV(\zeta)}{|\zeta - z| |\Phi(\zeta, z)|^{n+1}} \\ &\lesssim |f|_0 |\rho|_3 \delta(z)^{-1/2}. \end{aligned}$$

For  $J_3$  we use estimate [\(3-24\)](#),

$$\begin{aligned} (4-9) \quad |J_3(z)| &\lesssim |f|_0 |\rho|_3 \int_D |\zeta - z|^3 \left( \frac{|\Phi(z, \zeta)|^{n+1}}{|\overline{\Phi(\zeta, z)}|^{n+2} |\Phi(z, \zeta)|^{n+2}} \right. \\ &\quad \left. + \frac{|\overline{\Phi(\zeta, z)}|^{n+1}}{|\overline{\Phi(\zeta, z)}|^{n+2} |\Phi(z, \zeta)|^{n+2}} \right) dV(\zeta) \\ &= |f|_0 |\rho|_3 \int_D |\zeta - z|^3 \left( \frac{1}{|\overline{\Phi(\zeta, z)}|^{n+2} |\Phi(z, \zeta)|} \right. \\ &\quad \left. + \frac{1}{|\overline{\Phi(\zeta, z)}| |\Phi(z, \zeta)|^{n+2}} \right) dV(\zeta) \\ &\lesssim |f|_0 |\rho|_3 \left( \int_D \frac{|\zeta - z|}{|\overline{\Phi(\zeta, z)}|^{n+2}} dV(\zeta) + \int_D \frac{|\zeta - z|}{|\Phi(z, \zeta)|^{n+2}} dV(\zeta) \right) \\ &\lesssim |f|_0 |\rho|_3 \left( \int_D \frac{dV(\zeta)}{|\zeta - z| |\Phi(\zeta, z)|^{n+1}} + \int_D \frac{dV(\zeta)}{|\zeta - z| |\Phi(z, \zeta)|^{n+1}} \right) \\ &\lesssim |f|_0 |\rho|_3 \delta(z)^{-1/2}, \end{aligned}$$

where in the last inequality we applied [Lemma 3.2](#) with  $\beta = 1$ . Hence we have shown that

$$(4-10) \quad |I_2(z)| \lesssim |f|_0 |\rho|_3 \delta(z)^{-1/2}.$$

Combining [\(4-5\)](#) and [\(4-10\)](#), we have

$$\left| \frac{\partial \mathcal{K}'_1 f}{\partial z_j} \right| \lesssim \begin{cases} |f|_0 |\rho|_{3+\alpha} \delta(z)^{-1+\alpha} & \text{if } 0 < \alpha \leq \frac{1}{2}; \\ |f|_0 |\rho|_3 \delta(z)^{-1/2} & \text{if } \frac{1}{2} \leq \alpha \leq 1. \end{cases}$$

In a similar way we can show that  $|\partial_{\bar{z}_j} \mathcal{K}'_1 f|$  satisfies the same estimate. It follows by [Lemma 2.3](#) that

$$\mathcal{K}'_1 f \in \begin{cases} C^\alpha(\bar{D}) & \text{if } 0 < \alpha \leq \frac{1}{2}; \\ C^{1/2}(\bar{D}) & \text{if } \frac{1}{2} \leq \alpha \leq 1. \end{cases}$$

This completes the proof for the  $k = 0$  case.

Case 2:  $bD \in C^{k+3+\alpha}$ ,  $k \geq 1$  We now assume that  $\rho \in C^{k+3+\alpha}$ , for  $k \geq 1$ . Taking  $k + 1$  derivatives we get

$$(4-11) \quad \begin{aligned} & D_z^{k+1} \mathcal{K}'_1 f(z) \\ &= \sum_{\gamma_1 + \gamma_2 \leq k+1} \int_D f(\zeta) [D_z^{\gamma_1} \{\eta(z) + O''(|z-\zeta|)\} D_z^{\gamma_2} (\bar{\Phi}^{-(n+1)}(\zeta, z))] dV(\zeta) \\ &\quad - \sum_{\gamma_1 + \gamma_2 \leq k+1} \int_D f(\zeta) [D_z^{\gamma_1} \{\eta(\zeta) + O'(|z-\zeta|)\} D_z^{\gamma_2} (\Phi^{-(n+1)}(z, \zeta))] dV(\zeta) \\ &:= F_1 + F_2, \end{aligned}$$

where we denote the first and second sum in [\(4-11\)](#) by  $F_1$  and  $F_2$ , respectively. We break up into cases.

Case 1:  $\gamma_1 = k + 1$ . ( $\gamma_2 = 0$ ). By [\(3-18\)](#) and [\(3-21\)](#), we get

$$\begin{aligned} |D_z^{k+1} \{\eta(\zeta) + O'|\zeta - z|\}| &\lesssim |\rho|_{k+3}. \\ |D_z^{k+1} \{\eta(z) + O''|\zeta - z|\}| &\lesssim |\rho|_{k+3} + |\rho|_{k+4} |\zeta - z| \\ &\lesssim |\rho|_{k+3+\alpha} (1 + \delta(z)^{-1+\alpha} |\zeta - z|), \end{aligned}$$

where for the last inequality we used [\(4-1\)](#) with  $j = k + 4$ . By doing similar estimate as that for the integral  $I_1$  in the  $k = 0$  case, we get

$$|D^\gamma \mathcal{K}'_1 f(z)| \lesssim |\rho|_{k+3+\alpha} |f|_0 \delta(z)^{-1+\alpha}, \quad 0 < \alpha < 1.$$

Case 2:  $1 \leq \gamma_2 \leq k$  ( $\gamma_1 \leq k$ ). The term in the sum in (4-11) takes the form

$$(4-12) \quad \int_D f(\zeta) \left[ \frac{D_z^{\gamma_1} \{\eta(z) + O''(|z - \zeta|)\}}{\bar{\Phi}^{n+1+\tau}(\zeta, z)} S_\tau''(z, \zeta) \right] dV(\zeta) \\ - \int_D f(\zeta) \left[ \frac{D_z^{\gamma_1} \{\eta(\zeta) + O'(|z - \zeta|)\}}{\Phi^{n+1+\tau}(z, \zeta)} S_\tau'(z, \zeta) \right] dV(\zeta),$$

where  $\tau \leq \gamma_2 \leq k$  and  $S_\tau''(z, \zeta)$  is some linear combination of products of  $D_z^l \bar{\Phi}(\zeta, z)$ ,  $l \leq k$ , and  $S_\tau'$  is some linear combination of products of  $D_z^l \Phi(z, \zeta)$ ,  $l \leq k$ .

It is convenient to recall the notation:

$$(4-13) \quad Q'(z, \zeta) = \sum_{i=1}^n \frac{\partial \Phi(z, \zeta)}{\partial \bar{\zeta}_i} \frac{\partial \rho}{\partial \zeta_i}, \quad Q''(z, \zeta) = \sum_{i=1}^n \frac{\partial \overline{\Phi(\zeta, z)}}{\partial \bar{\zeta}_i} \cdot \frac{\partial \rho}{\partial \zeta_i},$$

and for  $|\zeta - z|$  small, we have

$$(4-14) \quad \Phi(z, \zeta) = F(z, \zeta) - \rho(\zeta) \\ = \sum_{j=1}^n \frac{\partial \rho}{\partial \zeta_j}(\zeta) (\zeta_j - z_j) - \frac{1}{2} \sum_{i,j=1}^n \frac{\partial^2 \rho}{\partial \zeta_i \partial \zeta_j}(\zeta) (z_i - \zeta_i)(z_j - \zeta_j) - \rho(\zeta);$$

$$(4-15) \quad \Phi(\zeta, z) = F(\zeta, z) - \rho(z) \\ = \sum_{j=1}^n \frac{\partial \rho}{\partial z_j}(z) (z_j - \zeta_j) - \frac{1}{2} \sum_{i,j=1}^n \frac{\partial^2 \rho}{\partial z_i \partial z_j}(z) (\zeta_i - z_i)(\zeta_j - z_j) - \rho(z).$$

For the first integral in (4-12), we apply integration by parts formulae (3-43) and (3-45) iteratively until the integral becomes, for  $\mu_0, \eta_0 \leq k$ , a linear combination of

$$(4-16) \quad \int_{bD} \frac{[D^{\mu_0} f(\zeta)] W_1''(z, \zeta)}{\bar{\Phi}^n(\zeta, z)} dV(\zeta), \quad \int_D \frac{[D^{\eta_0} f(\zeta)] W_2''(z, \zeta)}{\bar{\Phi}^{n+1}(\zeta, z)} dV(\zeta),$$

where  $W_1'', W_2''$  are some linear combinations of products of

$$D_\zeta^{\mu_1} D_z^{\gamma_1} \{\eta(z) + O''(|z - \zeta|)\}, \quad D_\zeta^{\mu_2} [(Q'')^{-1}], \quad D_\zeta^{\mu_3+1} D_z^l \overline{\Phi(\zeta, z)}, \quad D_\zeta^{\mu_4+1} \rho(\zeta),$$

for  $l \leq k$ , and  $\mu_i \geq 0$  satisfies  $\sum_{i=1}^4 \mu_i \leq k$ . Now we have  $|D_\zeta^{\mu_1} D_z^{\gamma_1} \{\eta(z) + O''(|z - \zeta|)\}| \leq C_k |\rho|_{k+2}$  (since  $\gamma_1 \leq k$ ,  $\mu_1 \leq k$ ),  $|D_\zeta^{\mu_2} [(Q'')^{-1}(z, \zeta)]| \leq C_k$ ,  $|D_\zeta^{\mu_3+1} D_z^l \overline{\Phi(\zeta, z)}| \leq C_k |\rho|_{k+1}$  (since  $l \leq k$ ). Hence the integrals in (4-16) and thus the first integral in (4-12) can be bounded by

$$(4-17) \quad |f|_k |\rho|_{k+3} \left( \int_{bD} \frac{d\sigma(\zeta)}{|\Phi(\zeta, z)|^n} + \int_D \frac{dV(\zeta)}{|\Phi(\zeta, z)|^{n+1}} \right) \\ \lesssim |f|_k |\rho|_{k+3} (1 + \log \delta(z)),$$

where we applied Lemma 3.4. For the second integral in (4-12), we apply formulae (3-44) and (3-45) iteratively until the integral becomes a linear combination of

$$(4-18) \quad \int_{bD} \frac{D^{\mu_0} f(\zeta) W_1'(z, \zeta)}{\Phi^n(z, \zeta)} dV(\zeta), \quad \int_D \frac{D^{\eta_0} f(\zeta) W_2'(z, \zeta)}{\Phi^{n+1}(z, \zeta)} dV(\zeta),$$

for  $\mu_0, \eta_0 \leq k$ . Here  $W_1'$  and  $W_2'$  are linear combinations of products of

$$D_\zeta^{\mu_1} D_z^{\gamma_1} \{\eta(\zeta) + O'(|z - \zeta|)\}, \quad D_\zeta^{\mu_2} [(Q')^{-1}], \quad D_\zeta^{\mu_3+1} D_z^l \Phi(z, \zeta), \quad D_\zeta^{\mu_4+1} \rho(\zeta),$$

where  $l \leq k$  and  $\mu_i \geq 0$  satisfies  $\sum_{i=1}^4 \mu_i \leq k$ . We have  $|D_\zeta^{\mu_1} D_z^{\gamma_1} \{\eta(\zeta) + O'(|z - \zeta|)\}| \leq C_k |\rho|_{\mu_1+3} \leq |\rho|_{k+3}$  (since  $\gamma_1, \mu_1 \leq k$ ),  $|D_\zeta^{\mu_2} [(Q')^{-1}]| \lesssim |\rho|_{\mu_2+3} \lesssim |\rho|_{k+3}$ , and  $|D_\zeta^{\mu_3+1} D_z^l \Phi(z, \zeta)| \lesssim C_k |\rho|_{\mu_3+3} \lesssim |\rho|_{k+3}$ . It follows that the integrals in (4-18) and hence the second integral in (4-12) is bounded by

$$(4-19) \quad |f|_k |\rho|_{k+3} \left( \int_{bD} \frac{d\sigma(\zeta)}{|\Phi(z, \zeta)|^n} + \int_D \frac{dV(\zeta)}{|\Phi(z, \zeta)|^{n+1}} \right) \lesssim |f|_k |\rho|_{k+3} (1 + \log \delta(z)).$$

Combining (4-17) and (4-19), we get for this case

$$|D^\gamma \mathcal{K}'_1 f(z)| \lesssim |\rho|_{k+3} |f|_k (1 + \log \delta(z)).$$

Case 3:  $\gamma_2 = k + 1$  ( $\gamma_1 = 0$ ). Applying integration by parts formulae (3-43), (3-44) and (3-45) iteratively to  $F_1(z)$  in (4-11) yields a linear combination of

$$(4-20) \quad \int_{bD} \frac{D^{\eta_0} f(\zeta) R_0''(z, \zeta)}{\bar{\Phi}^{n+1}(\zeta, z)} dV(\zeta), \quad \int_D \frac{D^{\mu_0} f(\zeta) R_1''(z, \zeta)}{\bar{\Phi}^{n+2}(\zeta, z)} dV(\zeta),$$

for  $\eta_0, \mu_0 \leq k$ . Similarly we apply integration by parts to  $F_2(z)$  until it becomes a linear combination of

$$(4-21) \quad \int_{bD} \frac{D^{\eta_0} f(\zeta) R_0'(z, \zeta)}{\Phi^{n+1}(z, \zeta)} dV(\zeta), \quad \int_D \frac{D^{\mu_0} f(\zeta) R_1'(z, \zeta)}{\Phi^{n+2}(z, \zeta)} dV(\zeta).$$

Here  $R_0''(z, \zeta)$  and  $R_1''(z, \zeta)$  are some linear combination of products of

$$D_\zeta^{\mu_1} (\eta(z) + O''(|z - \zeta|)), \quad D_\zeta^{\mu_2} [(Q'')^{-1}], \quad D_\zeta^{\mu_3+1} \bar{\Phi}(\zeta, z), \\ D_\zeta^{\mu_4} D_z \bar{\Phi}(\zeta, z), \quad D_\zeta^{\mu_5+1} \rho(\zeta),$$

and  $R_0'(z, \zeta)$  and  $R_1'(z, \zeta)$  are some linear combination of the products of

$$(4-22) \quad D_\zeta^{\mu_1} (\eta(\zeta) + O'(|z - \zeta|)), \quad D_\zeta^{\mu_2} [(Q')^{-1}], \quad D_\zeta^{\mu_3+1} \Phi(z, \zeta), \\ D_\zeta^{\mu_4} D_z \Phi(z, \zeta), \quad D_\zeta^{\mu_5+1} \rho(\zeta),$$

where  $0 \leq \mu_i \leq k$  for  $0 \leq i \leq 5$ , and  $\sum_{i=0}^5 \mu_i \leq k$ . There are five subcases to consider:

**Subcase 1:**  $\gamma_2 = k + 1$ ,  $\mu_0, \mu_1, \mu_2, \mu_3 \leq k - 1$ . Then we do integration by parts one more time to the integrals in (4-21) and the resulting integrals become

$$(4-23) \quad \int_{bD} \frac{D^{\tilde{\mu}_0} f(\zeta) R'_0(z, \zeta)}{\Phi^n(z, \zeta)} dV(\zeta), \quad \int_D \frac{D^{\tilde{\mu}_0} f(\zeta) R'_1(z, \zeta)}{\Phi^{n+1}(z, \zeta)} dV(\zeta),$$

where  $\tilde{\eta}_0, \tilde{\mu}_0 \leq k$ , and  $\tilde{R}'_0$  and  $\tilde{R}'_1$  are linear combinations of products of

$$D_{\zeta}^{\tilde{\mu}_1}(\eta(\zeta) + O'(|z - \zeta|)), \quad D_{\zeta}^{\tilde{\mu}_2}[(Q')^{-1}], \quad D_{\zeta}^{\tilde{\mu}_3+1} \Phi(z, \zeta), \\ D_{\zeta}^{\tilde{\mu}_4} D_z \Phi(z, \zeta), \quad D_{\zeta}^{\tilde{\mu}_5+1} \rho(\zeta),$$

with  $\tilde{\mu}_0, \tilde{\mu}_1, \tilde{\mu}_2, \tilde{\mu}_3 \leq k$  and  $\sum_i \tilde{\mu}_i \leq k + 1$ . Then

$$|D_{\zeta}^{\tilde{\mu}_1}(\eta(\zeta) + O'(|z - \zeta|))| \lesssim |\rho|_{k+3}.$$

In view of (3-38) and (3-39), we have

$$(4-24) \quad |D_{\zeta}^l Q'(z, \zeta)| = D_{\zeta}^l \left( \sum_{i=1}^n \frac{\partial \Phi(z, \zeta)}{\partial \bar{\zeta}_i} \frac{\partial \rho}{\partial \zeta_i} \right) \lesssim |\rho|_{l+2} + |\rho|_{l+3} |\zeta - z| \lesssim |\rho|_{l+3},$$

and similarly  $|D_{\zeta}^{l+1} \Phi(z, \zeta)| \lesssim |\rho|_{l+3}$ . Hence for  $\tilde{\mu}_2, \tilde{\mu}_3 \leq k$ , we have  $|D^{\tilde{\mu}_2}[(Q')^{-1}]|, |D^{\tilde{\mu}_3+1} \Phi(z, \zeta)| \lesssim |\rho|_{k+3}$ . Putting together the estimates, it follows that the integrals in (4-23) and thus in (4-21) satisfy

$$\left| \int_{bD} \frac{D^{\tilde{\mu}_0} f(\zeta) R'_0(z, \zeta)}{\Phi^n(z, \zeta)} dV(\zeta) \right| \lesssim |f|_k |\rho|_{k+3} \int_{bD} \frac{d\sigma(\zeta)}{|\Phi(z, \zeta)|^n} \\ \lesssim |f|_k |\rho|_{k+3} (1 + \log \delta(z)); \\ \left| \int_D \frac{D^{\tilde{\mu}_0} f(\zeta) R'_1(z, \zeta)}{\Phi^{n+1}(z, \zeta)} dV(\zeta) \right| \lesssim |f|_k |\rho|_{k+3} \int_D \frac{dV(\zeta)}{|\Phi(z, \zeta)|^{n+1}} \\ \lesssim |f|_k |\rho|_{k+3} (1 + \log \delta(z)).$$

We can obtain similar estimates for the integrals in (4-20), where the proof is easier since the functions  $R''_0$  and  $R''_1$  are  $C^\infty$  in  $\zeta$ . In conclusion we have shown that in this case

$$|D_z^\gamma \mathcal{K}'_1 f(z)| \lesssim |\rho|_{k+3} |f|_k (1 + \log \delta(z)).$$

**Subcase 2:**  $\gamma_2 = k + 1$ ,  $\mu_1 = k$ . Again we shall only estimate (4-21) as a similar procedure can be applied to (4-20). The integrals in (4-21) can be written as

$$(4-25) \quad \int_{bD} \frac{f(\zeta) D_{\zeta}^k [\eta(\zeta) + O'|z - \zeta|] R'_0(z, \zeta)}{\Phi^{n+1}(z, \zeta)} d\sigma(\zeta), \\ \int_D \frac{f(\zeta) D_{\zeta}^k [\eta(\zeta) + O'|z - \zeta|] R'_1(z, \zeta)}{\Phi^{n+2}(z, \zeta)} dV(\zeta),$$



where  $R'_0$  and  $R'_1$  are some linear combination of the products of

$$(Q')^{-1}, \quad D_z \Phi(z, \zeta), \quad D_\zeta \Phi(z, \zeta), \quad D\rho(\zeta).$$

We now estimate the domain integral in (4-25) which can be written as  $B_1 + B_2$ , where

$$(4-26) \quad \begin{aligned} B_1(z) &= \int_D \frac{f(\zeta) D_\zeta^k \eta(\zeta) R'_1(z, \zeta)}{\Phi^{n+2}(z, \zeta)} dV(\zeta), \\ B_2(z) &= \int_D \frac{f(\zeta) D_\zeta^k [O'(|z - \zeta|)] R'_1(z, \zeta)}{\Phi^{n+2}(z, \zeta)} dV(\zeta). \end{aligned}$$

We apply integration by parts formulae (3-43) and (3-45) to  $B_1$  so that

$$\begin{aligned} B_1(z) &= \int_{bD} \frac{D_\zeta^{\tilde{\nu}_0} f(\zeta) D_\zeta^{k+\tilde{\nu}_1} \eta(\zeta) \tilde{R}'_{10}(z, \zeta)}{\Phi^n(z, \zeta)} d\sigma(\zeta) \\ &\quad + \int_D \frac{D_\zeta^{\tilde{\mu}_0} f(\zeta) D_\zeta^{k+\tilde{\mu}_1} \eta(\zeta) \tilde{R}'_{11}(z, \zeta)}{\Phi^{n+1}(z, \zeta)} dV(\zeta). \end{aligned}$$

Here  $\tilde{\nu}_0, \tilde{\mu}_0, \tilde{\mu}_1 \leq 1$ .  $\tilde{R}'_{10}(z, \zeta)$  and  $\tilde{R}'_{11}(z, \zeta)$  are linear combinations of the products of

$$\widehat{D}_\zeta (Q')^{-1}, \quad \widehat{D}_\zeta D_z \Phi(z, \zeta), \quad \widehat{D}_\zeta^2 \Phi(z, \zeta), \quad \widehat{D}_\zeta^2 \rho(\zeta).$$

In particular  $|\tilde{R}'_{10}(z, \zeta)|, |\tilde{R}'_{11}(z, \zeta)| \lesssim |\rho|_4 \lesssim |\rho|_{k+3}$  ( $k \geq 1$ ). It follows from (4-26) that

$$\begin{aligned} |B_1(z)| &\lesssim |f|_1 |\rho|_4 \left( \int_{bD} \frac{d\sigma(\zeta)}{|\Phi(z, \zeta)|^n} + \int_D \frac{dV(\zeta)}{|\Phi(z, \zeta)|^{n+1}} \right) \\ &\lesssim |f|_1 |\rho|_{k+3} (1 + \log \delta(z)), \quad k \geq 1. \end{aligned}$$

For  $B_2$ , we use estimate (3-18),

$$D_\zeta^k [O'(|z - \zeta|)] = g_1(z, \zeta) + g_2(z, \zeta),$$

where  $|g_1(z, \zeta)| \lesssim |\rho|_{k+2}$  and  $|g_2| \lesssim |\rho|_{k+3} |\zeta - z|$ . Write

$$(4-27) \quad B_2(z) = \int_D \frac{f(\zeta) (g_1 R'_1)(z, \zeta)}{\Phi^{n+2}(z, \zeta)} dV(\zeta) + \int_D \frac{f(\zeta) (g_2 R'_1)(z, \zeta)}{\Phi^{n+2}(z, \zeta)} dV(\zeta).$$

The second integral is bounded in absolute value by (up to a constant)

$$|f|_0 |\rho|_{k+3} \int_D \frac{|\zeta - z|}{|\Phi(z, \zeta)|^{n+2}} dV(\zeta) \lesssim |f|_0 |\rho|_{k+3} \int_D \frac{dV(\zeta)}{|\zeta - z| |\Phi(z, \zeta)|^{n+1}} \lesssim \delta(z)^{-1/2}.$$

For the first integral in (4-27) we apply integration by parts and the resulting integral is bounded up to a constant by

$$(4-28) \quad |f|_1 |\rho|_{k+3} \left( \int_{bD} \frac{d\sigma(\zeta)}{\Phi^n(z, \zeta)} + \int_D \frac{dV(\zeta)}{\Phi^{n+1}(z, \zeta)} \right) \lesssim |f|_1 |\rho|_{k+3} (1 + \log \delta(z)).$$

This shows that  $|B_2(z)| \lesssim |f|_1 |\rho|_{k+3} \delta(z)^{-1/2}$ . Combining the estimates we have shown that the domain integral in (4-25) is bounded by  $C|f|_1 |\rho|_{k+3} \delta(z)^{-1/2}$ . The estimate for the boundary integral in (4-25) is similar and we leave the details to the reader. In summary we have in this case

$$|D_z^\gamma \mathcal{K}'_1 f(z)| \lesssim |\rho|_{k+3} |f|_1 \delta(z)^{-1/2}.$$

Subcase 3:  $\gamma_2 = k + 1$ ,  $\mu_2 = k$  in (4-22). From (4-13) we can write out  $Q'$  as

$$Q'(z, \zeta) = \sum_{i=1}^n \frac{\partial \Phi(z, \zeta)}{\partial \bar{\zeta}_i} \frac{\partial \rho}{\partial \zeta_i} = \sum_{i=1}^n \left( -\frac{\partial \rho}{\partial \bar{\zeta}_i} + O(|\zeta - z|) \right) \frac{\partial \rho}{\partial \zeta_i},$$

with

$$O(|\zeta - z|) \sim \widehat{D}_\zeta^3 \rho(\zeta) (\zeta_i - z_i).$$

In view of (3-38) and (3-39), we can write  $D_\zeta^k [(Q')^{-1}] = Y_1(z, \zeta) + Y_2(z, \zeta)$ , where  $|Y_1(z, \zeta)| \lesssim |\rho|_{k+2}$  and  $|Y_2(z, \zeta)| \lesssim |\rho|_{k+3} |z - \zeta|$ . The integrals in (4-21) have the form

$$(4-29) \quad \int_{bD} \frac{f(\zeta) D_\zeta^k [(Q')^{-1}] W_0(z, \zeta)}{\Phi^{n+1}(z, \zeta)} d\sigma(\zeta), \\ \int_D \frac{f(\zeta) D_\zeta^k [(Q')^{-1}] W_1(z, \zeta)}{\Phi^{n+2}(z, \zeta)} dV(\zeta).$$

Here  $W_0$  and  $W_1$  are some linear combinations of the products of  $D_\zeta \rho$ ,  $D_z \Phi(z, \zeta)$ ,  $D_\zeta \Phi(z, \zeta)$  and  $\eta(\zeta) + O'(|z - \zeta|)$ . For the domain integral in (4-29) we have

$$(4-30) \quad \int_D \frac{f(\zeta) D_\zeta^k [(Q')^{-1}] W_1(z, \zeta)}{\Phi^{n+2}(z, \zeta)} dV(\zeta) \\ = \int_D \frac{f(\zeta) [Y_1 W_1](z, \zeta)}{\Phi^{n+2}(z, \zeta)} dV(\zeta) + \int_D \frac{f(\zeta) [Y_2 W_1](z, \zeta)}{\Phi^{n+2}(z, \zeta)} dV(\zeta).$$

For the first term we use integration by parts. Since  $|D_\zeta Y_1(z, \zeta)| \lesssim |\rho|_{k+3}$ , the resulting integral is bounded by the expression (4-28). For the second term in (4-30)

we estimate directly

$$\begin{aligned} \left| \int_D \frac{f(\zeta)[Y_2 W_1](z, \zeta)}{\Phi^{n+2}(z, \zeta)} dV(\zeta) \right| &\lesssim |f|_0 |\rho|_{k+3} \int_D \frac{|\zeta - z|}{|\Phi(z, \zeta)|^{n+2}} dV(\zeta) \\ &\lesssim |f|_0 |\rho|_{k+3} \int_D \frac{dV(\zeta)}{|\zeta - z| |\Phi(z, \zeta)|^{n+1}} \\ &\lesssim |f|_0 |\rho|_{k+3} \delta(z)^{-1/2}, \end{aligned}$$

where in the last inequality we applied estimate (3-25) with  $\beta = 1$ . Thus the absolute value of the domain integral in (4-29) is bounded up to constant by  $|\rho|_{k+3} |f|_1 \delta(z)^{-1/2}$ . We can similarly show the same bound for the boundary integral in (4-29). Hence in this case

$$|D_z^\gamma \mathcal{K}'_1 f(z)| \lesssim |\rho|_{k+3} |f|_1 \delta(z)^{-1/2}.$$

Subcase 4:  $\gamma_2 = k + 1, \mu_3 = k$  in (4-22). Then the integrals in (4-21) take the form

$$\int_{bD} \frac{f(\zeta) D_\zeta^{k+1} \Phi(z, \zeta) W_0(z, \zeta)}{\Phi^{n+1}(z, \zeta)} dV(\zeta), \quad \int_D \frac{f(\zeta) D_\zeta^{k+1} \Phi(z, \zeta) W_1(z, \zeta)}{\Phi^{n+2}(z, \zeta)} dV(\zeta),$$

where  $W_0, W_1$  are some linear combinations of the products of  $D_\zeta \rho(\zeta), D_z \Phi(z, \zeta), D_\zeta \Phi(z, \zeta)$  and  $\eta(\zeta) + O'(|z - \zeta|)$ . As in the subcase 3 we can write  $D_\zeta^{k+1} \Phi(z, \zeta) = Y_1 + Y_2$ , where  $|D_\zeta^{k+1} Y_1(z, \zeta)| \lesssim |\rho|_{k+2}$  and  $|D_\zeta^{k+1} Y_2(z, \zeta)| \lesssim |\rho|_{k+3} |\zeta - z|$ . The rest of the estimates are the same as in Subcase 3.

Subcase 5:  $\gamma_2 = k + 1, \mu_0 = k$ . Then the integrals in (4-20) can be written as

$$\int_{bD} \frac{D^k f(\zeta) A''_0(z, \zeta)}{\overline{\Phi}^{n+1}(\zeta, z)} d\sigma(\zeta), \quad \int_D \frac{D^k f(\zeta) A''_1(z, \zeta)}{\overline{\Phi}^{n+2}(\zeta, z)} dV(\zeta),$$

where  $A''_0$  and  $A''_1$  are some linear combination of products of

$$\eta(z) + O''(|z - \zeta|), \quad (Q'')^{-1}, \quad D_\zeta \overline{\Phi(\zeta, z)}, \quad D_z \overline{\Phi(\zeta, z)}, \quad D_\zeta \rho(\zeta).$$

Likewise, the integrals in (4-21) can be written as

$$\int_{bD} \frac{D^k f(\zeta) A'_0(z, \zeta)}{\Phi^{n+1}(z, \zeta)} d\sigma(\zeta), \quad \int_D \frac{D^k f(\zeta) A'_1(z, \zeta)}{\Phi^{n+2}(z, \zeta)} dV(\zeta),$$

where  $A'_0$  and  $A'_1$  are linear combination of products of

$$\eta(\zeta) + O'(|z - \zeta|), \quad (Q')^{-1}, \quad D_\zeta \Phi(z, \zeta), \quad D_z \Phi(z, \zeta), \quad D_\zeta \rho(\zeta),$$

with coefficients identical to the linear combination  $A_0''$  and  $A_1''$ , respectively. In view of (4-11), it suffices to estimate the difference

$$\int_{bD} D^k f(\zeta) \left( \frac{A_0''(z, \zeta)}{\overline{\Phi}^{n+1}(\zeta, z)} - \frac{A_0'(z, \zeta)}{\Phi^{n+1}(z, \zeta)} \right) d\sigma(\zeta),$$

$$\int_D D^k f(\zeta) \left( \frac{A_1''(z, \zeta)}{\overline{\Phi}^{n+2}(\zeta, z)} - \frac{A_1'(z, \zeta)}{\Phi^{n+2}(z, \zeta)} \right) dV(\zeta).$$

We shall again estimate only the domain integral as the proof for the boundary integral is similar. By the expression for  $\eta$  and Lemma 3.9, we have

$$|\eta(z) - \eta(\zeta)| \lesssim |\rho|_3 |\zeta - z|, \quad |D_\zeta \overline{\Phi}(\zeta, z) - D_\zeta \Phi(z, \zeta)| \lesssim |\rho|_3 |\zeta - z|$$

$$|D_z \overline{\Phi}(\zeta, z) - D_z \Phi(z, \zeta)| \lesssim |\rho|_3 |\zeta - z|, \quad |Q''(z, \zeta) - Q'(z, \zeta)| \lesssim |\rho|_3 |\zeta - z|.$$

By procedure similar to the estimates of the  $I_2$  integral in the  $k = 0$  case, we can prove the following estimate:

$$\left| \int_D D^k f(\zeta) \left( \frac{A_1''(z, \zeta)}{\overline{\Phi}^{n+2}(\zeta, z)} - \frac{A_1'(z, \zeta)}{\Phi^{n+2}(z, \zeta)} \right) dV(\zeta) \right| \lesssim |\rho|_3 |f|_k \delta(z)^{-1/2}.$$

Consequently we conclude that in this case

$$|D_z^\gamma \mathcal{K}'_1 f(z)| \lesssim |\rho|_3 |f|_k \delta(z)^{-1/2}.$$

Finally combining the results from all cases we have shown that

$$|D_z^{k+1} \mathcal{K}'_1 f(z)| \lesssim \begin{cases} |f|_k |\rho|_{k+3+\alpha} \delta(z)^{-1+\alpha} & \text{if } 0 < \alpha \leq \frac{1}{2}; \\ |f|_k |\rho|_{k+3} \delta(z)^{-1/2} & \text{if } \frac{1}{2} \leq \alpha \leq 1. \end{cases}$$

By Lemma 2.3,  $\mathcal{K}'_1 f \in C^{k+\min\{\alpha, 1/2\}}(\overline{D})$ . Combined with earlier estimates for  $\mathcal{K}'_1 f$  and  $\mathcal{K}_0 f$ , the proof of Proposition 1.2 is now complete.  $\square$

**Proposition 4.1.** *Let  $D$  be a strictly pseudoconvex domain with  $C^3$  boundary. Let  $f$  be a function in  $C^1(\overline{\Omega})$  such that  $\bar{\partial} f \in C^1(\overline{\Omega})$ . Then the following formula holds:*

$$f(z) = \mathcal{L}f(z) + \int_D S_z(\bar{\partial}_z \bar{\partial}_\zeta N)(z, \cdot) \wedge f - \int_D N(z, \cdot) \wedge \bar{\partial} f$$

$$+ \int_{bD} \Omega_{0,0}^{01}(z, \cdot) \wedge \bar{\partial} f + \int_D \Omega_{0,0}^0(z, \cdot) \wedge \bar{\partial} f, \quad z \in D.$$

Here  $N$  and  $\mathcal{L}$  are given by formulae (3-13) (3-19).

*Proof.* Starting with the Bochner–Martinelli formula, see for example [Chen and Shaw 2001, Theorem 2.2.1],

$$f(z) = \int_{bD} \Omega_{0,0}^0(z, \zeta) \wedge f(\zeta) + \int_D \Omega_{0,0}^0(z, \zeta) \wedge \bar{\partial} f, \quad z \in D.$$

By (3-14), (3-15) and Stokes' theorem, we have

$$\begin{aligned}
 f(z) &= \int_{bD} N(z, \cdot) \wedge f + \int_{bD} \bar{\partial}_\zeta \Omega_{0,0}^{01}(z, \cdot) \wedge f + \int_D \Omega_{0,0}^0(z, \zeta) \wedge \bar{\partial} f \\
 &= \int_D \bar{\partial}_\zeta N(z, \cdot) \wedge f - \int_D N(z, \cdot) \wedge \bar{\partial} f + \int_{bD} \Omega_{0,0}^{01}(z, \cdot) \wedge \bar{\partial} f \\
 &\quad + \int_D \Omega_{0,0}^0(z, \zeta) \wedge \bar{\partial} f \\
 &= \mathcal{L}f(z) + \int_D S_z(\bar{\partial}_z \bar{\partial}_\zeta N)(z, \cdot) \wedge f - \int_D N(z, \cdot) \wedge \bar{\partial} f \\
 &\quad + \int_{bD} \Omega_{0,0}^{01}(z, \cdot) \wedge \bar{\partial} f + \int_D \Omega_{0,0}^0(z, \zeta) \wedge \bar{\partial} f. \quad \square
 \end{aligned}$$

**Proposition 4.2.** *Let  $D$  be a bounded strictly pseudoconvex domain with  $C^{k+3+\alpha}$  boundary, with  $0 < \alpha \leq 1$ . Suppose  $f$  is orthogonal to the Bergman space  $H^2(D)$ , is  $C^\infty$  in  $D$  and is holomorphic in  $D \setminus D_{-\delta}$ , for some  $\delta > 0$ . Then*

$$f \in C^{k+\min\{\alpha, 1/2\}}(\bar{D}).$$

Here we recall the notation.

$$D_{-\delta} := \{z \in D : \rho(z) < -\delta\}.$$

*Proof.* Let  $\mathcal{P}$  be the Bergman projection for  $D$ . By assumption  $\mathcal{P}f \equiv 0$ . By Proposition 3.6,  $\mathcal{L}^*f = (I + \mathcal{K})\mathcal{P}f \equiv 0$ , which implies that

$$\mathcal{K}f = \mathcal{L}^*f - \mathcal{L}f = -\mathcal{L}f.$$

Consequently by Proposition 4.1 and the assumption that  $\bar{\partial}f \equiv 0$  on  $bD$ ,

$$\begin{aligned}
 (4-31) \quad f(z) &= -\mathcal{K}f(z) + \int_D S_z(\bar{\partial}_z \bar{\partial}_\zeta N)(z, \cdot) \wedge f - \int_D N(z, \cdot) \wedge \bar{\partial} f \\
 &\quad + \int_{bD} \Omega_{0,0}^{01}(z, \cdot) \wedge \bar{\partial} f + \int_D \Omega_{0,0}^0(z, \cdot) \wedge \bar{\partial} f \\
 &= -\mathcal{K}f(z) + \int_D S_z(\bar{\partial}_z \bar{\partial}_\zeta N)(z, \cdot) \wedge f - \int_D N(z, \cdot) \wedge \bar{\partial} f \\
 &\quad + \int_D \Omega_{0,0}^0(z, \cdot) \wedge \bar{\partial} f,
 \end{aligned}$$

for  $z \in D$ . Here the kernels  $\Omega_{0,0}^0$  and  $N$  are given by formulae (3-11) and (3-13) on  $D$ :

$$(4-32) \quad N(z, \zeta) = \frac{1}{(2\pi\sqrt{-1})^n} \frac{1}{[G(z, \zeta) - \rho(\zeta)]^n} \\ \times \left( \sum g_1^i(z, \zeta) d\zeta_i \right) \wedge \left( \sum_i \bar{\partial}_\zeta g_1^i(z, \zeta) \wedge d\zeta_i \right)^{n-1},$$

$$\Omega_{0,0}^0(z, \zeta) = \frac{1}{(2\pi\sqrt{-1})^n} \frac{1}{|\zeta - z|^{2n}} \\ \times \sum_{i=1}^n (\bar{\zeta}_i - \bar{z}_i) d\zeta_i \wedge \left( \sum_{j=1}^n (d\bar{\zeta}_j - d\bar{z}_j) \wedge d\zeta_j \right)^{n-1},$$

where  $G$  and  $g_1$  are given by expressions (3-5) and (3-6). We can rewrite (4-31) as

$$(4-33) \quad f + \mathcal{K}f = h := h_1 + h_2 + h_3,$$

where we denote

$$h_1(z) := \int_D S_z(\bar{\partial}_z \bar{\partial}_\zeta N)(z, \cdot) \wedge f,$$

$$h_2(z) := - \int_D N(z, \cdot) \wedge \bar{\partial} f,$$

$$h_3(z) := \int_D \Omega_{0,0}^0(z, \cdot) \wedge \bar{\partial} f.$$

We show that each  $h_i$  defines a function in  $C^\infty(\bar{D})$ . By the first statement in (4-2), we have  $h_1 \in C^\infty(\bar{D})$ . For  $h_2$ , note that the functions  $G(z, \zeta)$ ,  $g_1(z, \zeta)$  are  $C^\infty$  in  $z$ , and the following estimate (see (3-8)) holds

$$G(z, \zeta) - \rho(\zeta) \geq c(-\rho(z) - \rho(\zeta) + |z - \zeta|^2), \quad z, \zeta \in \bar{D}.$$

In particular, for  $\zeta \in \text{supp}(\bar{\partial} f)$ , i.e.,  $\zeta \in D_{-\delta}$ , the function  $G(z, \zeta) - \rho(\zeta)$  is bounded below by some positive constant for all  $z \in \bar{D}$ . Hence in view of (4-32),  $h_2 \in C^\infty(\bar{D})$ . To see that  $h_3 \in C^\infty(\bar{D})$ , we note that by assumption  $\bar{\partial} f \in C_c^\infty(D)$ , and the argument is done using integration by parts.

Now, by Proposition 1.2,  $\mathcal{K}$  is a compact operator on the Banach space  $C^k(\bar{D})$ . Thus by the Fredholm alternative, either  $I + \mathcal{K}$  is invertible or  $\ker(I + \mathcal{K})$  is nonempty. Suppose  $f \in \ker(I + \mathcal{K})$ ; then  $f = -\mathcal{K}f$  and  $\sqrt{-1}\mathcal{K}f = -\sqrt{-1}f$ . If  $f \neq 0$ , this would imply that  $-\sqrt{-1}$  is an eigenvalue of the operator  $\sqrt{-1}\mathcal{K}$ , which is impossible since  $\sqrt{-1}\mathcal{K}$  is self-adjoint and have only real eigenvalues. Therefore we conclude that  $f \equiv 0$ , and  $\ker(I + \mathcal{K}) = \emptyset$ . This implies  $I + \mathcal{K}$  is an invertible operator on the space  $C^k(\bar{D})$ .

Applying this to (4-33) and  $h \in C^\infty(\bar{\Omega})$ , we obtain  $f \in C^k(\bar{D})$ . By Proposition 1.2, we have  $\mathcal{K}f \in C^{k+\min\{\alpha, 1/2\}}(\bar{D})$ . Hence  $f = -\mathcal{K}f + h \in C^{k+\min\{\alpha, 1/2\}}(\bar{D})$ .  $\square$

We can now finally prove Theorem 1.1.

*Proof of Theorem 1.1.* Fix  $w_0 \in D$ , we can write the  $B(\cdot, w_0) = \mathcal{P}\varphi$ , where  $\varphi \in C_c^\infty(D)$ . Applying Proposition 4.2 to  $f = \mathcal{P}\varphi - \varphi$  we get  $\mathcal{P}\varphi - \varphi \in C^{k+\min\{\alpha, 1/2\}}(\bar{D})$ . Hence  $\mathcal{P}\varphi \in C^{k+\min\{\alpha, 1/2\}}(\bar{D})$ .  $\square$

## 5. Proof of Theorem 1.3

In this section we prove Theorem 1.3, which will also follow from Proposition 1.2. First we need an approximation lemma.

**Lemma 5.1.** *Let  $D$  be a bounded Lipschitz domain in  $\mathbb{R}^N$ . Suppose  $f \in C^{k+\beta}(\bar{D})$ , where  $k$  is a nonnegative integer and  $0 < \beta < 1$ . Then there exists a family  $\{f_\varepsilon\}_{\varepsilon>0} \in C^\infty(D) \cap C^{k+\beta}(\bar{D})$  such that  $f_\varepsilon$  converges to  $f$  uniformly as  $\varepsilon \rightarrow 0$ . Furthermore,  $|f_\varepsilon|_{k+\beta}$  is uniformly bounded by  $|f|_{k+\beta}$ .*

**Remark 5.2.** Let  $f_\varepsilon$  be constructed as above. It follows from [Shi 2023, Proposition 2.3] that  $f_\varepsilon$  converges to  $f$  in  $|\cdot|_\tau$ , for any  $0 \leq \tau < k + \beta$ .

*Proof.* It suffices to take  $D$  as a special Lipschitz domain of the form  $\omega = \{x \in \mathbb{R}^N : x_N > \psi(x_1, \dots, x_{n-1}), |\psi|_{L^\infty} \leq C\}$ , as the general case follows by standard partition of unity argument. There exists some cone  $K$  such that for any  $x \in \omega$ ,  $x + K \subseteq \omega$ . Let  $\phi$  be a  $C^\infty$  with compact supported in  $-K$  and such that  $\phi \geq 0$  and  $\int_{\mathbb{R}^N} \phi = 1$ . Let  $\phi_\varepsilon = \frac{1}{\varepsilon^n} \phi(\frac{x}{\varepsilon})$ . Then we can define for  $x \in \omega$  the function

$$f_\varepsilon(x) = f * \phi_\varepsilon(x) = \int_{-K} f(x - \varepsilon y) \phi(y) dV(y).$$

It is clear that  $f_\varepsilon \in C^\infty(D)$  and

$$\begin{aligned} |f_\varepsilon(x) - f(x)| &= \left| \int_{-K} [f(x - \varepsilon y) - f(x)] \phi(y) dV(y) \right| \\ &\leq \int_{-K} |f(x - \varepsilon y) - f(x)| \phi(y) dV(y) \\ &\leq |f|_\beta \varepsilon^\beta \int_{-K} y^\alpha \phi(y) dV(y) \\ &\lesssim |f|_\beta \varepsilon^\beta. \end{aligned}$$

Hence  $f_\varepsilon$  converges to  $f$  uniformly in  $\omega$ . Let  $x_1, x_2 \in \omega$ . Then for all  $\varepsilon > 0$ ,

$$\begin{aligned} |f_\varepsilon(x_1) - f_\varepsilon(x_2)| &= \left| \int_{-K} [f(x_1 - \varepsilon y) - f(x_2 - \varepsilon y)] \phi(y) dV(y) \right| \\ &\leq |f|_\beta |x_1 - x_2|^\beta. \end{aligned}$$

Accordingly  $|f_\varepsilon|_\beta$  is uniformly bounded by  $|f|_\beta$ . This proves the case  $k = 0$ . For  $k \geq 1$  the proof is similar and we leave the details to the reader.  $\square$

**Lemma 5.3.** *Let  $D$  be a strictly pseudoconvex domain in  $\mathbb{C}^n$  with  $C^{k+3}$  boundary, where  $k$  is a nonnegative integer. Then for any  $\beta > 0$ ,*

$$|\mathcal{L}f|_k \lesssim |f|_{k+\beta}.$$

*Proof.* Write  $D_z^k \mathcal{L}f(z)$  as a linear combination of

$$(5-1) \quad \int_D f(\zeta) \frac{W(z, \zeta)}{\Phi^{n+1+\mu}(z, \zeta)} dV(\zeta), \quad \mu \leq k,$$

where  $W(z, \zeta)$  is some linear combination of products of

$$D_z^{\tau_1}[l(\zeta) + O'(|z - \zeta|)], \quad D_z^{\tau_2} \Phi(z, \zeta), \quad \mu_1, \mu_2 \leq k.$$

Applying integration by parts formulae (3-43) and (3-45) iteratively to the integral (5-1) until it can be written as a linear combination of

$$(5-2) \quad \int_{bD} D^{\eta_0} f(\zeta) \frac{W_0(z, \zeta)}{\Phi^{n+1}(z, \zeta)} d\sigma(\zeta), \quad \int_D D^{\mu_0} f(\zeta) \frac{W_1(z, \zeta)}{\Phi^{n+1}(z, \zeta)} dV(\zeta),$$

where  $\eta_0, \mu_0 \leq k$ . Here  $W_0$  and  $W_1$  are some linear combination of

$$(5-3) \quad D_\zeta^{\mu_1} D_z^{\tau_1}[l(\zeta) + O'(|z - \zeta|)], \quad D_\zeta^{\mu_2} [(Q')^{-1}], \quad D_\zeta^{\mu_3+1} \Phi(z, \zeta), \\ D_\zeta^{\mu_4} D_z^{\tau_2} \Phi(z, \zeta), \quad D_\zeta^{\mu_5+1} \rho(\zeta),$$

with  $\mu_i \leq k, 0 \leq i \leq 5$  and  $\sum_{i=0}^5 \mu_i \leq k$ . We shall only estimate the domain integral in (5-2), as the proof of the boundary integral is similar. In view of (5-3), we can write  $W_1(z, \zeta) = Y_1(z, \zeta) + Y_2(z, \zeta)$ , where  $|Y_1(z, \zeta)| \lesssim |\rho|_{k+2}$ , and  $|Y_2(z, \zeta)| \lesssim |\rho|_{k+3} |\zeta - z|$ . Write

$$\int_D D^{\mu_0} f(\zeta) \frac{W_1(z, \zeta)}{\Phi^{n+1}(z, \zeta)} dV(\zeta) \\ = \int_D D^{\mu_0} f(\zeta) \frac{Y_1(z, \zeta)}{\Phi^{n+1}(z, \zeta)} dV(\zeta) + \int_D D^{\mu_0} f(\zeta) \frac{Y_2(z, \zeta)}{\Phi^{n+1}(z, \zeta)} dV(\zeta).$$

The  $Y_2$  integral is bounded by

$$\left| \int_D D^{\mu_0} f(\zeta) \frac{Y_2(z, \zeta)}{\Phi^{n+1}(z, \zeta)} dV(\zeta) \right| \lesssim |\rho|_{k+3} |f|_k \int_D \frac{|\zeta - z|}{|\Phi(z, \zeta)|^{n+1}} \lesssim |\rho|_{k+3} |f|_k,$$



where we used (3-26). For the  $Y_1$  integral we use the assumption that  $f \in C^{k+\beta}$ ,  $\beta > 0$ ,

$$\begin{aligned} & \int_D D^{\mu_0} f(\zeta) \frac{Y_1(z, \zeta)}{\Phi^{n+1}(z, \zeta)} dV(\zeta) \\ &= \int_D [D^{\mu_0} f(\zeta) - D^{\mu_0} f(z)] \frac{Y_1(z, \zeta)}{\Phi^{n+1}(z, \zeta)} dV(\zeta) + D^{\mu_0} f(z) \int_D \frac{Y_1(z, \zeta) dV(\zeta)}{\Phi^{n+1}(z, \zeta)}. \end{aligned}$$

The first integral on the right-hand side is bounded by

$$|\rho|_{k+2} |f|_{k+\beta} \int_D \frac{|\zeta - z|^\beta dV(\zeta)}{|\Phi^{n+1}(z, \zeta)|} \lesssim |\rho|_{k+2} |f|_{k+\beta}.$$

For the other integral, since  $Y_1$  involves derivatives of  $\rho$  up to order  $k+2$ , we can apply integration by parts and take one more derivative of  $\rho$  against  $\zeta$ . The resulting integrals are bounded by  $|\rho|_{k+3}$  up to a constant. Summing up the estimates we have

$$\left| \int_D D^{\mu_0} f(\zeta) \frac{Y_1(z, \zeta)}{\Phi^{n+1}(z, \zeta)} dV(\zeta) \right| \lesssim |\rho|_{k+3} |f|_{k+\beta}.$$

Consequently this shows that  $|D_z^k \mathcal{L}f(z)| \lesssim |\rho|_{k+3} |f|_{k+\beta}$ , finishing the proof.  $\square$

We are now ready to prove [Theorem 1.3](#).

**Proposition 5.4.** *Let  $D$  be a strictly pseudoconvex domain in  $\mathbb{C}^n$ . Let  $k$  be a nonnegative integer, and  $0 < \alpha, \beta \leq 1$ :*

- (i) *Suppose  $bD \in C^{k+3}$ . Then  $\mathcal{L}$  defines a bounded operator from  $C^{k+\beta}(\bar{D})$  to  $C^{k+\beta/2}(\bar{D})$ .*
- (ii) *Suppose  $bD \in C^{k+3+\alpha}$ . Then  $\mathcal{P}, \mathcal{L}^*$  define bounded operators from  $C^{k+\beta}(\bar{D})$  to  $C^{k+\min\{\alpha, \beta/2\}}(\bar{D})$ .*

*Proof.* (i) We first prove the statement for  $\mathcal{L}$  and we begin by considering the case  $k=0$ . Assume first that  $0 < \beta < 1$ . Let  $f \in C^\beta(\bar{D})$  and  $\{f_\varepsilon\}_{\varepsilon>0}$  be the functions constructed in [Lemma 5.1](#). In particular, we have:

- (1)  $f_\varepsilon \in C^\infty(D) \cap C^\beta(\bar{D})$ ;
- (2)  $|f_\varepsilon - f|_\eta \rightarrow 0$ , for any  $0 \leq \eta < \beta$  ([Remark 5.2](#)).

We claim that for each  $\mathcal{L}f_\varepsilon \in C^{\beta/2}(\bar{D})$  with  $|\mathcal{L}f_\varepsilon|_{\beta/2}$  uniformly bounded by some constant  $C_0$ . Assuming the claim holds, then for any  $z_1, z_2 \in D$ , we have

$$\begin{aligned} (5-4) \quad & |\mathcal{L}f(z_1) - \mathcal{L}f(z_2)| \\ & \leq |\mathcal{L}f(z_1) - \mathcal{L}f_\varepsilon(z_1)| + |\mathcal{L}f_\varepsilon(z_1) - \mathcal{L}f_\varepsilon(z_2)| + |\mathcal{L}f(z_2) - \mathcal{L}f_\varepsilon(z_2)| \\ & \leq 2|\mathcal{L}(f - f_\varepsilon)|_0 + |\mathcal{L}f_\varepsilon|_{\beta/2} |z_1 - z_2|^{\beta/2} \\ & \leq 2|\mathcal{L}(f - f_\varepsilon)|_0 + C_0 |z_1 - z_2|^{\beta/2}. \end{aligned}$$

Now, given a function  $g \in C^\eta(\bar{D})$  with  $\eta > 0$ , using the reproducing property of  $\mathcal{L}$  we have

$$(5-5) \quad \begin{aligned} |\mathcal{L}g(z)| &= \left| \int_D [g(\zeta) - g(z)]L(z, \zeta) dV(\zeta) + g(z) \right| \\ &\lesssim |\rho|_2 |g|_\eta \int_D \frac{|z - \zeta|^\eta}{|\Phi(z, \zeta)|^{n+1}} dV(\zeta) + |g|_0 \\ &\lesssim (|\rho|_2 + 1) |g|_\eta, \end{aligned}$$

where in the last inequality we applied [Lemma 3.2](#).

Applying (5-5) with  $g = f - f_\varepsilon$  and using property (2) from above, we get  $|\mathcal{L}(f - f_\varepsilon)|_0 \rightarrow 0$  as  $\varepsilon \rightarrow 0$ . It follows from (5-4) that  $|\mathcal{L}f(z_1) - \mathcal{L}f(z_2)| \leq C_0 |z_1 - z_2|^{\beta/2}$ . This shows that  $\mathcal{L}f \in C^{\beta/2}(\bar{D})$ .

It remains to prove the claim, namely,  $|\mathcal{L}f_\varepsilon|_{\beta/2}$  is bounded by some constant  $C_0$  independent of  $\varepsilon$ . To this end, we will show that  $|\mathcal{L}f_\varepsilon|_{\beta/2} \leq C'_0 |f_\varepsilon|_\beta$ , where  $C'_0$  depends only on  $|\rho|_3$ . Since  $|f_\varepsilon|_\beta \leq |f|_\beta$ , this proves the claim.

For  $f_\varepsilon \in C^\infty(D) \cap C^\beta(\bar{D})$ , we have

$$f_\varepsilon(z) - \mathcal{L}f_\varepsilon(z) = \int_D [f_\varepsilon(z) - f_\varepsilon(\zeta)]L(z, \zeta) dV(\zeta),$$

where we used the reproducing property of kernel  $L$ :  $\int_D L(z, \zeta) dV(\zeta) \equiv 1$ . Then

$$\frac{\partial f_\varepsilon}{\partial z_i}(z) - \frac{\partial \mathcal{L}f_\varepsilon}{\partial z_i}(z) = \int_D \frac{\partial f_\varepsilon}{\partial z_i}(z) L(z, \zeta) dV(\zeta) + \int_D [f_\varepsilon(z) - f_\varepsilon(\zeta)] \frac{\partial L}{\partial z_i}(z, \zeta) dV(\zeta).$$

The first term on each side cancels out, which leaves us with

$$\begin{aligned} &\frac{\partial \mathcal{L}}{\partial z_i}(z, \zeta) dV(\zeta) \\ &= \int_D [f_\varepsilon(\zeta) - f_\varepsilon(z)] \frac{\partial L}{\partial z_i}(z, \zeta) dV(\zeta) \\ &= \int_D [f_\varepsilon(\zeta) - f_\varepsilon(z)] \\ &\quad \times \left[ \frac{\partial_{z_i} [l(\zeta) + O'(|z - \zeta|)]}{\Phi^{n+1}(z, \zeta)} - (n+1) \frac{[l(\zeta) + O'(|z - \zeta|)] \partial_{z_i} \Phi(z, \zeta)}{\Phi^{n+2}(z, \zeta)} \right] dV(\zeta). \end{aligned}$$

For  $\bar{z}_i$  derivatives we have a similar expression. By estimate (3-18) and (3-9), we obtain

$$\begin{aligned} |\nabla \mathcal{L}f_\varepsilon(z)| &\lesssim |\rho|_3 |f_\varepsilon|_\beta \left( \int_D \frac{|z - \zeta|^\beta}{|\Phi(z, \zeta)|^{n+1}} dV(\zeta) + \int_D \frac{|z - \zeta|^\beta}{|\Phi(z, \zeta)|^{n+2}} dV(\zeta) \right) \\ &\lesssim |\rho|_3 |f_\varepsilon|_\beta \left( \int_D \frac{|z - \zeta|^\beta}{|\Phi(z, \zeta)|^{n+1}} dV(\zeta) + \int_D \frac{dV(\zeta)}{|\zeta - z|^{2-\beta} \Phi(z, \zeta)^{n+1}} \right) \\ &\lesssim |\rho|_3 |f_\varepsilon|_\beta (1 + \delta(z)^{-1+\beta/2}), \end{aligned}$$

where in the last step we applied [Lemma 3.2](#). It follows by Hardy–Littlewood lemma that  $\mathcal{L}f_\varepsilon \in C^{\beta/2}(\bar{D})$  and  $|\mathcal{L}f_\varepsilon|_{\beta/2}$  is bounded by  $C'_0|f_\varepsilon|_\beta$ , where  $C'_0$  depends only on  $|\rho|_3$ . Combined with the earlier argument, this proves (i) for  $k = 0$  and  $0 < \beta < 1$ . If  $k = 0$  and  $\beta = 1$ , we can repeat the above proof without doing the approximation, obtaining in the end

$$|\nabla \mathcal{L}f(z)| \lesssim |\rho|_3 |f|_1 (1 + \delta(z))^{-1/2}, \quad z \in D.$$

Hence by Hardy–Littlewood lemma,  $\mathcal{L}f \in C^{1/2}(\bar{D})$ .

Next we consider the case  $k \geq 1$ . Suppose  $f \in C^{k+\beta}(\bar{D})$ , for  $0 < \beta < 1$ . As before we first construct  $\{f_\varepsilon\}_{\varepsilon>0}$  such that

- (1)  $f_\varepsilon \in C^\infty(D) \cap C^{k+\beta}(\bar{D})$ ;
- (2)  $|f_\varepsilon - f|_\eta \rightarrow 0$ , for any  $0 \leq \eta < k + \beta$ .

We claim that  $|\mathcal{L}f_\varepsilon|_{k+\beta/2}$  is bounded uniformly by some constant  $C_0$ . Assuming the validity of the claim, for  $z_1, z_2 \in D$  and  $\ell \leq k$ , we have

$$\begin{aligned} (5-6) \quad |D^\ell \mathcal{L}f(z_1) - D^\ell \mathcal{L}f(z_2)| &\leq |D^\ell \mathcal{L}f(z_1) - D^\ell \mathcal{L}f_\varepsilon(z_1)| \\ &\quad + |D^\ell \mathcal{L}f_\varepsilon(z_1) - D^\ell \mathcal{L}f_\varepsilon(z_2)| \\ &\quad + |D^\ell \mathcal{L}f(z_2) - D^\ell \mathcal{L}f_\varepsilon(z_2)| \\ &\leq 2|\mathcal{L}(f - f_\varepsilon)|_\ell + |\mathcal{L}f_\varepsilon|_{k+\beta/2} |z_1 - z_2|^{\beta/2} \\ &\leq 2|\mathcal{L}(f - f_\varepsilon)|_k + C_0 |z_1 - z_2|^{\beta/2}. \end{aligned}$$

As before we want to show that

$$|\mathcal{L}(f - f_\varepsilon)|_k \rightarrow 0 \quad \text{as } \varepsilon \rightarrow 0.$$

Here the estimate is more subtle since  $D\mathcal{L}g = \mathcal{L}Dg$  does not hold and thus one cannot estimate as easily as in (5-5). Instead we apply [Lemma 5.3](#) to get

$$(5-7) \quad |\mathcal{L}(f - f_\varepsilon)|_k \lesssim |f - f_\varepsilon|_{k+\tau}, \quad \text{for any } \tau > 0.$$

By property (2) above, we have  $|f - f_\varepsilon|_\eta \rightarrow 0$  for any  $\eta < k + \beta$ . Hence (5-7) implies  $|\mathcal{L}(f - f_\varepsilon)|_k \rightarrow 0$ . Letting  $\varepsilon \rightarrow 0$  in (5-6), we get  $\mathcal{L}f \in C^{k+\beta/2}(\bar{D})$ , which proves the reduction.

To finish the proof it remains to show that there exists a constant  $C'_0 > 0$  (which we will show depends only on  $|\rho|_{k+\beta}$ ) such that  $|\mathcal{L}f_\varepsilon|_{k+\beta/2} \leq C'_0|f_\varepsilon|_{k+\beta}$ . Then by

**Lemma 5.1** we get  $|\mathcal{L}f_\varepsilon|_{k+\beta/2} \leq C'_0|f_\varepsilon|_{k+\beta} \leq C'_0|f|_{k+\beta}$ . We have

$$\begin{aligned} & D_z^{k+1}[f_\varepsilon(z) - \mathcal{L}f_\varepsilon(z)] \\ &= D_z^{k+1} \int_D [f_\varepsilon(z) - f_\varepsilon(\zeta)]L(z, \zeta) dV(\zeta) \\ &= \int_D D_z^{k+1} f_\varepsilon(z)L(z, \zeta) dV(\zeta) + \int_D \sum_{\substack{\gamma_1+\gamma_2=k+1 \\ 1 \leq \gamma_2 \leq k}} D_z^{\gamma_1} f_\varepsilon(z) D_z^{\gamma_2} L(z, \zeta) dV(\zeta) \\ & \quad + \int_D (f_\varepsilon(z) - f_\varepsilon(\zeta)) D_z^{k+1} L(z, \zeta) dV(\zeta). \end{aligned}$$

The first integral is equal to  $D_z^{k+1} f(z)$ . Hence

$$\begin{aligned} D_z^{k+1} \mathcal{L}f_\varepsilon(z) &= - \int_D \sum_{\substack{\gamma_1+\gamma_2=k+1 \\ 1 \leq \gamma_2 \leq k}} D_z^{\gamma_1} f_\varepsilon(z) D_z^{\gamma_2} L(z, \zeta) dV(\zeta) \\ & \quad + \int_D [f_\varepsilon(\zeta) - f_\varepsilon(z)] D_z^{k+1} L(z, \zeta) dV(\zeta) \\ &:= I_1 + I_2, \end{aligned}$$

where we denote the first and second integral by  $I_1$  and  $I_2$ , respectively. For  $I_1$ , we can write it as a linear combination of integrals of the form

$$(5-8) \quad D_z^{\mu_0} f_\varepsilon(z) \int_D \frac{W(z, \zeta)}{\Phi^{n+1+\mu_1}(z, \zeta)} dV(\zeta), \quad \mu_0, \mu_1 \leq k,$$

where  $W$  is some linear combination of  $D_z^{\mu_2}[l(\zeta) + O'(|z - \zeta|)]$  and  $D_z^{\mu_3} \Phi(z, \zeta)$  with  $\mu_2, \mu_3 \leq k$ . We apply integration by parts formulae (3-43) and (3-44) iteratively to the integral in (5-8) until it can be written as a linear combination of

$$(5-9) \quad \int_{bD} \frac{W_0(z, \zeta)}{\Phi^n(z, \zeta)} d\sigma(\zeta), \quad \int_D \frac{W_1(z, \zeta)}{\Phi^{n+1}(z, \zeta)} dV(\zeta).$$

Here  $W_0, W_1$  are linear combinations of products of

$$\begin{aligned} & D_\zeta^{\tau_1} D_{z_i}^{\mu_2} [l(\zeta) + O'(|z - \zeta|)], \quad D_\zeta^{\tau_2} [(Q')^{-1}], \quad D_\zeta^{\tau_3+1} \Phi(z, \zeta), \\ & D_\zeta^{\tau_4} D_z^{\mu_3} \Phi(z, \zeta), \quad D_\zeta^{\tau_5+1} \rho(\zeta), \end{aligned}$$

with  $\tau_i \leq k, 1 \leq i \leq 5$ . Note that all these quantities are bounded by some constant multiple of  $|\rho|_{k+3}$ . It follows that the integrals in (5-9) and hence  $I_1$  is bounded by

$$\begin{aligned} (5-10) \quad |I_1| &\lesssim |f_\varepsilon|_k |\rho|_{k+3} \left( \int_{bD} \frac{d\sigma(\zeta)}{|\Phi(z, \zeta)|^n} + \int_D \frac{dV(\zeta)}{|\Phi(z, \zeta)|^{n+1}} \right) \\ &\lesssim |f_\varepsilon|_k |\rho|_{k+3} (1 + \log \delta(z)), \end{aligned}$$

where we applied [Lemma 3.4](#). The integral  $I_2$  can be written as a linear combination of integrals of the form

$$(5-11) \quad \int_D \frac{[f_\varepsilon(\zeta) - f_\varepsilon(z)]W(z, \zeta)}{\Phi^{n+2+\mu}(z, \zeta)} dV(\zeta), \quad \mu \leq k.$$

Here  $W(z, \zeta)$  is some linear combination of

$$D_z^{\tau_0}[l(\zeta) + O'(|z - \zeta|)], \quad D_z^{\tau_1}\Phi(z, \zeta), \quad \tau_0, \tau_1 \leq k + 1.$$

If  $\mu \leq k - 1$  we can integrate by parts and estimate just like  $I_1$  to show that  $|I_2| \lesssim |f_\varepsilon|_k |\rho|_{k+3} (1 + \log|\delta(z)|)$ . If  $\mu = k$ , we apply integration by parts formulae [\(3-43\)](#) and [\(3-45\)](#) until the integral [\(5-11\)](#) can be expressed as a linear combination of integrals of the form

$$(5-12) \quad \int_{bD} \frac{D_\zeta^{\eta_0} f_\varepsilon(\zeta) A_0(z, \zeta)}{\Phi^{n+1}(z, \zeta)} d\sigma(\zeta), \quad \int_D \frac{D^{\mu_0} f_\varepsilon(\zeta) A_1(z, \zeta)}{\Phi^{n+2}(z, \zeta)} dV(\zeta),$$

for  $\eta_0, \mu_0 \leq k$ . Here  $A_0, A_1$  are linear combination of products of

$$(5-13) \quad D_\zeta^{\mu_1}[l(\zeta) + O'(|z - \zeta|)], \quad D_\zeta^{\mu_2}[(Q')^{-1}], \quad D_\zeta^{\mu_3+1}\Phi(z, \zeta), \\ D_\zeta^{\mu_4} D_z \Phi(z, \zeta), \quad D_\zeta^{\mu_5+1} \rho(\zeta),$$

where  $\mu_i \leq k$ , and  $\sum_{i=0}^5 \mu_i = k$ . We now use the fact that  $\rho \in C^\infty(D) \cap C^{k+3}(\bar{D})$  satisfies the estimate

$$|D_z^j \rho(z)| \lesssim C_j |\rho|_{k+3} (1 + \delta(z)^{k+3-j}), \quad j = 0, 1, 2, \dots$$

We shall only estimate the domain integral in [\(5-12\)](#), as the estimate for the boundary integral is similar. In view of [\(5-13\)](#) we can write  $A_1(z, \zeta) = X_1(z, \zeta) + X_2(z, \zeta)$ , where  $|X_1(z, \zeta)| \lesssim |\rho|_{k+2}$  and  $|X_2(z, \zeta)| \lesssim |\rho|_{k+3} |\zeta - z|$ . Write

$$\int_D \frac{D^{\mu_0} f_\varepsilon(\zeta) A_1(z, \zeta)}{\Phi^{n+2}(z, \zeta)} dV(\zeta) \\ = \int_D \frac{D^{\mu_0} f_\varepsilon(\zeta) X_1(z, \zeta)}{\Phi^{n+2}(z, \zeta)} dV(\zeta) + \int_D \frac{D^{\mu_0} f_\varepsilon(\zeta) X_2(z, \zeta)}{\Phi^{n+2}(z, \zeta)} dV(\zeta).$$

By estimates [\(3-9\)](#) and [\(3-25\)](#), we see that

$$\left| \int_D \frac{D^{\mu_0} f_\varepsilon(\zeta) X_2(z, \zeta)}{\Phi^{n+2}(z, \zeta)} dV(\zeta) \right| \lesssim |\rho|_{k+3} |f_\varepsilon|_k \int_D \frac{|\zeta - z|}{|\Phi(z, \zeta)|^{n+2}} dV(\zeta) \\ \lesssim |\rho|_{k+3} |f_\varepsilon|_k \int_D \frac{dV(\zeta)}{|\zeta - z| |\Phi(z, \zeta)|^{n+1}} \\ \lesssim |\rho|_{k+3} |f_\varepsilon|_k (1 + \delta(z)^{-1/2}), \quad \mu_0 \leq k.$$

On the other hand, we can write

$$\begin{aligned}
 (5-14) \quad & \int_D \frac{D^{\mu_0} f_\varepsilon(\zeta) X_1(z, \zeta)}{\Phi^{n+2}(z, \zeta)} dV(\zeta) \\
 &= \int_D \frac{[D_\zeta^{\mu_0} f_\varepsilon(\zeta) - D_z^{\mu_0} f_\varepsilon(z)] X_1(z, \zeta)}{\Phi^{n+2}(z, \zeta)} dV(\zeta) \\
 &\quad + D_z^{\mu_0} f_\varepsilon(z) \int_D \frac{X_1(z, \zeta)}{\Phi^{n+2}(z, \zeta)} dV(\zeta).
 \end{aligned}$$

Since  $f_\varepsilon \in C^{k+\beta}(\bar{D})$ , the first integral on the right-hand side above is bounded up to a constant by

$$\begin{aligned}
 |\rho|_{k+2} |f_\varepsilon|_{k+\beta} \int_D \frac{|\zeta - z|^\beta}{|\Phi(z, \zeta)|^{n+2}} dV(\zeta) &\lesssim |\rho|_{k+2} |f_\varepsilon|_{k+\beta} \int_D \frac{dV(\zeta)}{|\zeta - z|^{2-\beta} |\Phi(z, \zeta)|^{n+1}} \\
 &\lesssim |\rho|_{k+2} |f_\varepsilon|_{k+\beta} (1 + \delta(z)^{-1+\beta/2}).
 \end{aligned}$$

For the second integral on the right-hand side of (5-14), we can integrate by parts and bound the resulting expression by

$$|\rho|_{k+3} |f_\varepsilon|_k \left( \int_{bD} \frac{d\sigma(\zeta)}{|\Phi(z, \zeta)|^n} + \int_D \frac{dV(\zeta)}{|\Phi(z, \zeta)|^{n+1}} \right) \lesssim |\rho|_{k+3} |f_\varepsilon|_k (1 + \log \delta(z)).$$

Hence we have shown that

$$|I_2| \lesssim |f_\varepsilon|_{k+\beta} |\rho|_{k+3} (1 + \delta(z)^{-1+\beta/2}).$$

Combined with the estimate (5-10) for  $I_1$ , this shows that

$$|D_z^{k+1} \mathcal{L} f_\varepsilon(z)| \lesssim |f_\varepsilon|_{k+\beta} |\rho|_{k+3} (1 + \delta(z)^{-1+\beta/2}).$$

By Lemma 2.3,  $\mathcal{L} f_\varepsilon \in C^{k+\beta/2}(\bar{D})$  and  $|\mathcal{L} f_\varepsilon|_{k+\beta/2} \leq C'_0 |f_\varepsilon|_{k+\beta}$  where  $C'_0$  depends only on  $|\rho|_{k+3}$ . This proves the claim and hence the case when  $0 < \beta < 1$ . Finally if  $\beta = 1$ , the same proof works without the use of the approximation.

(ii) From Proposition 1.2 we know that  $\mathcal{K} f \in C^{k+\min\{\alpha, 1/2\}}(\bar{D})$  if  $f \in C^k(\bar{D})$  (and in particular if  $f \in C^{k+\beta}(\bar{D})$  for  $0 < \beta \leq 1$ ). By (i),  $\mathcal{L} f \in C^{k+\beta/2}(\bar{D})$ . Since  $\mathcal{L}^* f = \mathcal{K} f + \mathcal{L} f$ , and  $\min\{\alpha, \frac{1}{2}, \beta/2\} = \min\{\alpha, \beta/2\}$ , we have

$$\mathcal{L}^* f \in C^{k+\min\{\alpha, \beta/2\}}(\bar{D}).$$

Finally by the integral equation  $(I + \mathcal{K}) P f = \mathcal{L}^* f$ , and the fact that  $I + \mathcal{K}$  is invertible in the space  $C^k(\bar{D})$ , we get  $P f \in C^k(\bar{D})$  and thus  $\mathcal{K} P f \in C^{k+\min\{\alpha, 1/2\}}(\bar{D})$  by Proposition 1.2. Therefore  $P f = -\mathcal{K} P f + \mathcal{L}^* f \in C^{k+\min\{\alpha, \beta/2\}}(\bar{D})$ .  $\square$

## Acknowledgements

The author would like to thank the anonymous referee for many valuable suggestions that improve the exposition of the paper.

## References

- [Ahern and Schneider 1979] P. Ahern and R. Schneider, “Holomorphic Lipschitz functions in pseudoconvex domains”, *Amer. J. Math.* **101**:3 (1979), 543–565. [MR](#) [Zbl](#)
- [Bell 1993] S. Bell, “Unique continuation theorems for the  $\bar{\partial}$ -operator and applications”, *J. Geom. Anal.* **3**:3 (1993), 195–224. [MR](#) [Zbl](#)
- [Bell and Ligočka 1980] S. Bell and E. Ligočka, “A simplification and extension of Fefferman’s theorem on biholomorphic mappings”, *Invent. Math.* **57**:3 (1980), 283–289. [MR](#) [Zbl](#)
- [Chen and Shaw 2001] S.-C. Chen and M.-C. Shaw, *Partial differential equations in several complex variables*, AMS/IP Studies in Advanced Mathematics **19**, American Mathematical Society, Providence, RI, 2001. [MR](#) [Zbl](#)
- [Elgueta 1980] M. Elgueta, “Extension to strictly pseudoconvex domains of functions holomorphic in a submanifold in general position and  $C^\infty$  up to the boundary”, *Illinois J. Math.* **24**:1 (1980), 1–17. [MR](#) [Zbl](#)
- [Fefferman 1974] C. Fefferman, “The Bergman kernel and biholomorphic mappings of pseudoconvex domains”, *Invent. Math.* **26** (1974), 1–65. [MR](#) [Zbl](#)
- [Gong 2019] X. Gong, “Hölder estimates for homotopy operators on strictly pseudoconvex domains with  $C^2$  boundary”, *Math. Ann.* **374**:1-2 (2019), 841–880. [MR](#) [Zbl](#)
- [Hörmander 1965] L. Hörmander, “ $L^2$  estimates and existence theorems for the  $\bar{\partial}$  operator”, *Acta Math.* **113** (1965), 89–152. [MR](#)
- [Hörmander 1990] L. Hörmander, *An introduction to complex analysis in several variables*, 3rd ed., North-Holland Mathematical Library **7**, North-Holland Publishing Co., Amsterdam, 1990. [MR](#)
- [Kerzman 1972] N. Kerzman, “The Bergman kernel function: Differentiability at the boundary”, *Math. Ann.* **195** (1972), 149–158. [MR](#) [Zbl](#)
- [Kerzman and Stein 1978] N. Kerzman and E. M. Stein, “The Szegő kernel in terms of Cauchy–Fantappiè kernels”, *Duke Math. J.* **45**:2 (1978), 197–224. [MR](#) [Zbl](#)
- [Krantz 1976] S. G. Krantz, “Optimal Lipschitz and  $L^p$  regularity for the equation  $\bar{\partial}u = f$  on strongly pseudo-convex domains”, *Math. Ann.* **219**:3 (1976), 233–260. [MR](#)
- [Lanzani and Stein 2012] L. Lanzani and E. M. Stein, “The Bergman projection in  $L^p$  for domains with minimal smoothness”, *Illinois J. Math.* **56**:1 (2012), 127–154. [MR](#) [Zbl](#)
- [Lanzani and Stein 2013] L. Lanzani and E. M. Stein, “Cauchy-type integrals in several complex variables”, *Bull. Math. Sci.* **3**:2 (2013), 241–285. [MR](#) [Zbl](#)
- [Lieb and Range 1980] I. Lieb and R. M. Range, “Lösungsoperatoren für den Cauchy–Riemann-Komplex mit  $C^k$ -Abschätzungen”, *Math. Ann.* **253**:2 (1980), 145–164. [MR](#) [Zbl](#)
- [Ligočka 1984] E. Ligočka, “The Hölder continuity of the Bergman projection and proper holomorphic mappings”, *Studia Math.* **80**:2 (1984), 89–107. [MR](#) [Zbl](#)
- [Boutet de Monvel and Sjöstrand 1976] L. Boutet de Monvel and J. Sjöstrand, “Sur la singularité des noyaux de Bergman et de Szegő”, pp. 123–164 in *Journées: Équations aux Dérivées Partielles de Rennes* (Rennes, 1975), edited by J. Camus, Astérisque **34–35**, Société Mathématique de France, Paris, 1976. [MR](#) [Zbl](#)

- [Phong and Stein 1977] D. H. Phong and E. M. Stein, “Estimates for the Bergman and Szegő projections on strongly pseudo-convex domains”, *Duke Math. J.* **44**:3 (1977), 695–704. [MR](#) [Zbl](#)
- [Range 1986] R. M. Range, *Holomorphic functions and integral representations in several complex variables*, Graduate Texts in Mathematics **108**, Springer, 1986. [MR](#) [Zbl](#)
- [Shi 2023] Z. Shi, “Oblique derivative boundary value problems on families of planar domains”, *Bull. Sci. Math.* **183** (2023), Paper No. 103228, 91. [MR](#) [Zbl](#)
- [Webster 1979] S. M. Webster, “Biholomorphic mappings and the Bergman kernel off the diagonal”, *Invent. Math.* **51**:2 (1979), 155–169. [MR](#) [Zbl](#)
- [Wolff 2003] T. H. Wolff, *Lectures on harmonic analysis*, University Lecture Series **29**, American Mathematical Society, Providence, RI, 2003. [MR](#) [Zbl](#)

Received August 7, 2022. Revised February 8, 2023.

ZIMING SHI  
DEPARTMENT OF MATHEMATICS  
RUTGERS UNIVERSITY – NEW BRUNSWICK  
PISCATAWAY, NJ  
UNITED STATES  
[zs327@rutgers.edu](mailto:zs327@rutgers.edu)



## Guidelines for Authors

Authors may submit articles at [msp.org/pjm/about/journal/submissions.html](http://msp.org/pjm/about/journal/submissions.html) and choose an editor at that time. Exceptionally, a paper may be submitted in hard copy to one of the editors; authors should keep a copy.

By submitting a manuscript you assert that it is original and is not under consideration for publication elsewhere. Instructions on manuscript preparation are provided below. For further information, visit the web address above or write to [pacific@math.berkeley.edu](mailto:pacific@math.berkeley.edu) or to Pacific Journal of Mathematics, University of California, Los Angeles, CA 90095–1555. Correspondence by email is requested for convenience and speed.

Manuscripts must be in English, French or German. A brief abstract of about 150 words or less in English must be included. The abstract should be self-contained and not make any reference to the bibliography. Also required are keywords and subject classification for the article, and, for each author, postal address, affiliation (if appropriate) and email address if available. A home-page URL is optional.

Authors are encouraged to use  $\LaTeX$ , but papers in other varieties of  $\TeX$ , and exceptionally in other formats, are acceptable. At submission time only a PDF file is required; follow the instructions at the web address above. Carefully preserve all relevant files, such as  $\LaTeX$  sources and individual files for each figure; you will be asked to submit them upon acceptance of the paper.

Bibliographical references should be listed alphabetically at the end of the paper. All references in the bibliography should be cited in the text. Use of  $\text{Bib}\TeX$  is preferred but not required. Any bibliographical citation style may be used but tags will be converted to the house format (see a current issue for examples).

Figures, whether prepared electronically or hand-drawn, must be of publication quality. Figures prepared electronically should be submitted in Encapsulated PostScript (EPS) or in a form that can be converted to EPS, such as GnuPlot, Maple or Mathematica. Many drawing tools such as Adobe Illustrator and Aldus FreeHand can produce EPS output. Figures containing bitmaps should be generated at the highest possible resolution. If there is doubt whether a particular figure is in an acceptable format, the authors should check with production by sending an email to [pacific@math.berkeley.edu](mailto:pacific@math.berkeley.edu).

Each figure should be captioned and numbered, so that it can float. Small figures occupying no more than three lines of vertical space can be kept in the text (“the curve looks like this:”). It is acceptable to submit a manuscript with all figures at the end, if their placement is specified in the text by means of comments such as “Place Figure 1 here”. The same considerations apply to tables, which should be used sparingly.

Forced line breaks or page breaks should not be inserted in the document. There is no point in your trying to optimize line and page breaks in the original manuscript. The manuscript will be reformatted to use the journal’s preferred fonts and layout.

Page proofs will be made available to authors (or to the designated corresponding author) at a website in PDF format. Failure to acknowledge the receipt of proofs or to return corrections within the requested deadline may cause publication to be postponed.

# PACIFIC JOURNAL OF MATHEMATICS

Volume 324    No. 1    May 2023

---

Spike solutions for a fractional elliptic equation in a compact Riemannian manifold	1
IMENE BENDAHOU, ZIED KHEMIRI and FETHI MAHMOUDI	
On slice alternating 3-braid closures	49
VITALIJS BREJEVS	
Vanishing theorems and adjoint linear systems on normal surfaces in positive characteristic	71
MAKOTO ENOKIZONO	
Constructing knots with specified geometric limits	111
URS FUCHS, JESSICA S. PURCELL and JOHN STEWART	
An isoperimetric inequality of minimal hypersurfaces in spheres	143
FAGUI LI and NIANG CHEN	
Boundary regularity of Bergman kernel in Hölder space	157
ZIMING SHI	